

# Critical Release Notice

**Publication number: 297-2401-200**  
**Publication release: Standard 09.02**

The content of this customer NTP supports the  
SN06 (DMS) software release.

Bookmarks used in this NTP highlight the changes between the baseline NTP and the current release. The bookmarks provided are color-coded to identify release-specific content changes. NTP volumes that do not contain bookmarks indicate that the baseline NTP remains unchanged and is valid for the current release.

## Bookmark Color Legend

**Black:** Applies to new or modified content for the baseline NTP that is valid through the current release.

**Red:** Applies to new or modified content for NA017 that is valid through the current release.

**Blue:** Applies to new or modified content for NA018 (SN05 DMS) that is valid through the current release.

**Green:** Applies to new or modified content for SN06 (DMS) that is valid through the current release.

### *Attention!*

*Adobe® Acrobat® Reader™ 5.0 is required to view bookmarks in color.*

## **Publication History**

### **March 2004**

Standard release 09.02 for software release SN06 (DMS).

Updates to sections PRI Call Screening and PRI ISDN Treatments to specify applicability of AUDTRMT option, according to CR Q00757372 .

### **May 2003**

Standard release 09.01 for software release SN06 (DMS). Updates made to section PRI Call Screening according to CR Q00269204.

297-2401-200

DMS-100 Family

## **ISDN Primary Rate Interface**

ISDN Primary Rate Interface Service Implementation Guide

CNA14 and up Standard 08.01 September 2000

---



---

DMS-100 Family

# ISDN Primary Rate Interface

## ISDN Primary Rate Interface Service Implementation Guide

---

Publication number: 297-2401-200

Product release: CNA14 and up

Document release: Standard 08.01

Date: September 2000

---

Copyright © 1998-2000 Nortel Networks,  
All Rights Reserved

Printed in the United States of America

**NORTEL NETWORKS CONFIDENTIAL:** The information contained herein is the property of Nortel Networks and is strictly confidential. Except as expressly authorized in writing by Nortel Networks, the holder shall keep all information contained herein confidential, shall disclose the information only to its employees with a need to know, and shall protect the information, in whole or in part, from disclosure and dissemination to third parties with the same degree of care it uses to protect its own confidential information, but with no less than reasonable care. Except as expressly authorized in writing by Nortel Networks, the holder is granted no rights to use the information contained herein.

Information is subject to change without notice. Nortel Networks reserves the right to make changes in design or components as progress in engineering and manufacturing may warrant. Changes or modification to the DMS-100 without the express consent of Nortel Networks may void its warranty and void the users authority to operate the equipment.

Nortel Networks, the Nortel Networks logo, the Globemark, How the World Shares Ideas, Unified Networks, DMS, DMS-100, Helmsman, MAP, Meridian, Nortel, Northern Telecom, NT, SuperNode, and TOPS are trademarks of Nortel Networks.

---



---

# Publication history

---

## September 2000

Release 08.01. The following chapters of the *ISDN Primary Rate Interface Service Implementation Guide* were updated for this issue.

- Chapter 3-ISDN PRI software components was updated to remove the list of features that were new for NA013. Feature PRI Originating Calling Name Delivery was added for NA014
- Chapter 8-Logs was updated to remove a description of log report ISDN 404 that was new in NA013.
- Chapter 9-Operational measurements was updated to remove a description of OM group RTESVCS that was new in NA013.

## March 2000

Release 07.01. The following chapters of the *ISDN Primary Rate Interface Service Implementation Guide* were updated for this issue.

- Chapter 3-ISDN PRI software components was updated to remove the list of features that were new for NA012. Feature Call Forward/Interface Busy 9CFIB) was added for NA013.
- Chapter 6-Data schema was updated to include a translations description of Call Forward/Interface Busy.
- Chapter 8-Logs was updated to include a description of log report ISDN 404 and remove the log description of NCAS100 that was new in NA012.
- Chapter 9-Operational measurements was updated to include a description of OM group RTESVCS.

**October 1999**

Release 06.05. The following chapters were modified to reflect editing changes and minor template changes.

- Chapter 3-ISDN PRI software components
- Chapter 6-Data schema.
- Chapter 13-Advanced troubleshooting procedures

**August 1999**

Release 06.02, 06.03, and 06.04 were updates for release error corrections.

**August 1999**

Release 06.01. The following chapters of the *ISDN Primary Rate Interface Service Implementation Guide* were updated for this issue.

- Chapter 3-ISDN PRI software components was updated to remove the list of features that were new for NA011 and were replaced with a list of features that are new for NA012. the features added include the following:
  - “E911 Preferred DN”
  - “MSR Name Display and Universal DN System Support”
  - “NCAS Framework”
  - “PRI-PRI Over Multiple XPMs”
- Chapter 6-Data schema. Translations information for feature “E911 Preferred DN” was added.
- Chapter 8-Logs was updated to remove the information for logs that were new for NA011 and to add the description of log report NCAS100 which was introduced in NA012.
- Chapter 9-Operational measurements was updated to remove the information for OMs that were introduced in NA011.



---

**May 1999**

Release 05.02. The following chapters of the *ISDN Primary Rate Interface Service Implementation Guide* were updated for this issue.

- Chapter 3–ISDN PRI software components was updated to add feature “PRI: Base MWI Control Using NI-PRI.
- Chapter 6–Data schema. Translations information for feature “PRI: Base MWI Control Using NI-PRI was added.
- Chapter 9–Operational measurements was updated to include new OM groups MWICTCAP and PRIMWIC.

**March 1999**

Release 05.01. The following chapters of the *ISDN Primary Rate Interface Service Implementation Guide* were updated for NA011.

- Chapter 3–ISDN PRI software components was updated. The following feature descriptions were added.:
  - AF7585 “PRI with Semipermanent Packet (Provisioning and Querying Tools)”
  - AF7625 “PRI with Semipermanent Packet (Call Processing and Maintenance)”
  - AF7769/AF7770 “PRI: Location Indicators”
  - AF7772/AF7773 “PRI: Data Link Monitor”
  - AF7774/AF7775 “PRI: Service Disruptions and Abnormalities”
- Chapter 6–Data schema. Translations information for the PRI Semipermanent Packet feature was added.

- Chapter 8–Logs was updated as follows:
  - added two new log reports (ISDN401 and ISDN402) to Table 8-1, “Summary of ISDN PRI related logs”
  - added examples of log reports ISDN40 and ISDN402
- Chapter 10–User Interface was updated to add the following:
  - added descriptions of error messages for PKT PRI trunks at the MAP TTP level or sublevels
  - modified Figure 10-4, “TRKS level commands,” to show new PHTTP level commands

**November 1998**

Release 04.02. A minor revision to the front cover was made.

**November 1998**

Release 04.01. The following additions and changes have been made to the *ISDN Primary Rate Interface Service Implementation Guide* for NA010:

- The *ISDN Primary Rate Interface Implementation Guide* is renamed to the “ISDN Primary Rate Interface Service Implementation Guide”. This document replaces the previous implementation guide.
- The entire document was reformatted.
- NA010 features ‘ISP Even Call Distribution’ and ‘PRI SUSP for CNAME’ were added to Part 1, “Introduction” and Part 3, “Provisioning”.
- Maintenance information contained in 297-2401-202, *ISDN PRI Maintenance Guide* is reproduced in Part 4, “Operation, administration, and maintenance”.

---

# Contents

---

## ISDN Primary Rate Interface Service Implementation Guide

<b>Publication history</b>	<b>iii</b>
<hr/>	
<b>About this guide</b>	<b>xxv</b>
When to use this guide	xxv
How to check the version and issue of this document	xxv
References in this document	xxvi
Documentation numbering conventions	xxvi
What precautionary messages mean	xxix
How commands, parameters, and responses are represented	xxx
Input prompt (>)	xxx
Commands and fixed parameters	xxxi
Variables	xxxi
Responses	xxxi
Audience	xxxi
Important notice	xxxi
<hr/>	
<b>Part I Introduction</b>	<b>I-1</b>
<hr/>	
<b>1 ISDN PRI overview</b>	<b>1-1</b>
Introduction to ISDN	1-1
ISDN PRI overview	1-3
ISDN PRI background	1-3
ISDN PRI description	1-3
Applications	1-5
<hr/>	
<b>2 ISDN PRI hardware components</b>	<b>2-1</b>
ISDN PRI equipment	2-1
XPM hardware configuration	2-1
Peripheral side interface	2-2
PRI channels	2-2
D-channel protocol	2-6
Automatic maintenance	2-8
ISDN XPM automatic maintenance	2-8
Escalation to manual maintenance	2-9

- Card requirements 2-9
  - Shelf layouts 2-9
  - Cards 2-11
  - Card replacement procedures 2-16
- Fault conditions 2-16
  - Fault condition results 2-16

---

**3 ISDN PRI software components 3-1**

- OSI model and ISDN PRI protocols 3-1
  - Layer 1 (physical) protocol 3-1
  - Layer 2 (data link) protocol 3-3
  - Layer 3 (call control or network) protocol 3-4
- ISDN PRI features 3-4
  - Features added in NA014 3-4
    - Feature name 3-4
    - Description 3-4
    - Hardware requirements 3-10
    - Limitations and restrictions 3-10
  - Datafill 3-12
  - Service orders 3-12
  - Operational measurements 3-12
  - Logs 3-12
  - User interface 3-12
  - Billing 3-12
  - Other ISDN PRI features 3-13
  - B-channel Service Messaging 3-14
  - Call-by-call Service 3-14
  - Call Forward/Interface Busy 3-15
  - Calling Line Identification 3-15
  - Dialable Wideband Service 3-16
  - E911 Preferred DN 3-16
  - ISP Even Call Distribution 3-16
  - MSR Name Display and Universal DN System Support 3-16
  - NCAS Framework 3-16
  - Networked ACD on PRA 3-17
  - PRI Backup D-channel 3-17
  - PRI Base Service 3-17
  - PRI Bearer Capability Routing 3-17
  - PRI Call Routing 3-17
  - PRI Call Screening 3-17
  - PRI Calling Line Identification Blocking 3-18
  - PRI Calling Name Delivery 3-18
  - PRI Equal Access 3-18
  - PRI Flexible Timers 3-19
  - PRI Hotel/Motel and Selective Class of Call Screening for NIPRI 3-19
  - PRI ISDN Treatments 3-19
  - PRI Message Waiting Indicator 3-19
  - PRI Network Name Delivery 3-19
  - PRI Originating Calling Name Delivery 3-20
  - PRI Network Ring Again 3-20

---

PRI-PRI Over Multiple XPMs	3-21
PRI SUSP for CNAME	3-21
PRI Two B-channel Transfer	3-21
Release Link Trunk	3-21

---

## **Part II Functional description** **II-1**

---

### **4 ISDN PRI functional description** **4-1**

Purpose of ISDN PRI	4-1
ISDN PRI services	4-2
Signaling for PRI	4-2
ISDN signaling methods	4-3

---

## **Part III Planning and engineering** **III-1**

---

### **5 Engineering and provisioning** **5-1**

Hardware	5-1
DTCI	5-1
Software	5-3
Capacity	5-3
Physical connections	5-4
Customer datafill table flow	5-4
Hardware datafill	5-5
Table PMLOADS	5-5
Table CARRMTC	5-6
Table LTCINV	5-8
Table LTCPSINV	5-9

---

## **Part IV Provisioning** **IV-1**

---

### **6 Data schema** **6-1**

Datafilling trunk tables	6-1
Trunk tables	6-3
Hardware tables	6-3
Associated tables	6-4
Use of virtual facility groups to control trunk group size	6-4
Table STDPRCT	6-5
Table STDPRTCT:STDPRT	6-6
Table VIRTGRPS	6-6
Datafilling tables for specific features and services	6-9
B-channel service messaging	6-9
Call-by-call translations	6-10
Call routing translations	6-10
Call type significance	6-21
Release Line trunk	6-25
Enabling the RLT Option	6-36
Interactions	6-36
Restrictions and limitations	6-36

---

- Service Identifier Routing 6-37
  - Table ISAXLA 6-39
  - SID route TRAVER example 6-40
  - SID route TRAVER example with sizing 6-41
- Translations for specific PRI features and services 6-42
- Call Forward/Interface Busy 6-43
- E911 Preferred DN 6-56
- ISP Even Call Distribution 6-61
- Networked ACD on PRA 6-95
- PRI Backup D-channel 6-109
- PRI: Base MWI Control Using NI-PRI 6-114
- PRI Base Service 6-133
- PRI Bearer Capability Routing 6-176
- PRI Call Routing 6-244
- PRI Call Screening 6-298
- PRI Calling Line Identification Blocking 6-322
- PRI Calling Name Delivery 6-331
- PRI Equal Access 6-339
- PRI Flexible Timers 6-343
- PRI Hotel/Motel SCOCS 6-348
- PRI ISDN Treatments 6-367
- PRI Message Waiting indicator 6-370
- PRI Network Name Delivery 6-380
- PRI Network Ring Again 6-389
- PRI SUSP for CNAME 6-400
- PRI Two B-channel Transfer 6-409
- PRI with Semipermanent Packet 6-422

---

## **Part V Operation, administration, and maintenance V-1**

---

<b>7</b>	<b>Preventive maintenance strategies</b>	<b>7-1</b>
	Overall preventive maintenance 7-1	
	Maintenance manager's morning report 7-2	
	Switch Performance Monitoring System 7-3	
	Call processing performance rating 7-4	
	CPU occupancy indicator 7-5	
	SWACT indicator 7-5	
	Network integrity fail count indicator 7-5	
	Automatic trunk test (ATT) indicator 7-5	
	Routine exercise tests 7-5	
	REx test sequence 7-6	
	REx test restrictions 7-6	
	Network maintenance 7-7	
	Focused maintenance 7-7	
	Operational measurements 7-8	
	Routine maintenance 7-8	
<b>8</b>	<b>Logs</b>	<b>8-1</b>
	Log reports 8-1	
	Log utility 8-1	

---

ISDN PRI logs	8-1
Priority logs	8-7
Logs introduced in NA014	8-11

---

<b>9</b>	<b>Operational measurements</b>	<b>9-1</b>
	ISDN PRI OM groups	9-1
	ISDN PRI priority OM registers	9-6
	OM groups introduced in NA014	9-9

---

<b>10</b>	<b>Advanced troubleshooting procedures</b>	<b>10-1</b>
	B- and D-channel troubles	10-1
	Calls that do not complete	10-6
	Definition	10-6

---

<b>11</b>	<b>User interface</b>	<b>11-1</b>
	MAP level hierarchy	11-1
	Commands	11-2
	Menu MAP commands	11-2
	Unlisted MAP commands	11-9
	MAP level diagrams	11-10
	Status indicators	11-14
	Messages	11-17

---

<b>12</b>	<b>Trouble isolation and correction methods</b>	<b>12-1</b>
	Test tools	12-1
	Translation verification	12-2
	Display Call	12-2
	Peripheral module intercept system test	12-2
	Peripheral module debug	12-3
	CallTrak	12-3
	PRI maintenance model	12-4
	Hardware model	12-4
	Software or call control model	12-5
	General troubleshooting procedure	12-6
	Some notes on troubleshooting	12-7
	Initial installation troubles	12-7
	In-service troubles	12-8
	D-channel loopback	12-8
	DS-1 maintenance signaling notes	12-8
	Other DS-1 issues	12-9
	Testing for DS-1 line errors with BERT	12-10
	NT6X50AB DS-1 card maintenance notes	12-11
	DS-1 link error reporting	12-12
	DS-1 fault indications	12-12
	DS-1 alarm thresholds	12-13
	PM troubleshooting notes	12-14
	Auditing data mismatches	12-14
	Activity monitoring with PMACT and ISP commands	12-14
	Datafill issues	12-15
	Integrated service access (ISA) troubleshooting	12-16

---

	Troubleshooting PRI call processing 12-17	
	Circuit-switched call states 12-18	
	Global states 12-19	
	Call establishment at the originating interface 12-19	
	Call establishment at the destination interface 12-21	
	Call clearing 12-23	
	Interworking with existing networks 12-26	
	Restart procedure 12-27	
	Digital test access 12-28	
	DTA commands 12-29	
<b>13</b>	<b>Troubleshooting chart</b>	<b>13-1</b>
<b>14</b>	<b>Cause values</b>	<b>14-1</b>
	Mapping cause values to treatments 14-1	
	Mapping treatments to cause values 14-4	
<b>15</b>	<b>Troubleshooting example</b>	<b>15-1</b>
	Troubleshooting calls that will not complete 15-1	
	<b>List of terms</b>	<b>A-1</b>



---

## Figures

PRI integrated services access (ISA/call-by-call)	1-4
PRI out-of-band messaging	1-4
PRI configurations	1-5
Voice messaging systems application	1-6
Fax mail application	1-6
Call center load balancing application	1-7
LAN bridging application	1-7
Multi-point bridging application	1-8
Videoconferencing application	1-9
Distance learning application	1-9
PRI Internet access application	1-10
High speed data transfer application	1-11
Private line backup/augmentation application	1-11
XPM hardware configuration	2-2
PRI channels	2-3
B-channel data call example	2-4
PRI consolidated signaling	2-6
PRI D channel processing	2-7
DTCI shelf layout for an XPM configuration	2-10
LTC equipped for ISDN shelf layout	2-11
OSI and ISDN model comparison	3-1
DS-1 and Superframe signaling formats	3-3
A typical PRI network	4-2
XPM-PLUS dual unit node DTCI	5-2
PRI datafill table flow	5-5
Example of table PMLOADS	5-6
Example of table CARRMTC	5-7
Example of table LTCINV	5-8
Example of table LTCPSINV	5-9
Description of the interface identifier (IID)	5-11
PRI datafill table flow	6-2
Table flow for table STDPRTCT	6-5
Example of table STDPRTCT	6-5
Example of table STDPRTCT:STDPRT	6-5
Example of table VIRTGRPS	6-7
Example of data in table LTDATA	6-10
Standard routing	6-10
Example of table HNPACONT:RTEREF	6-11
Example of table HNPACONT	6-13
Example of table HNPACONT:HNPACODE	6-13
Example of table LINEATTR	6-14
Example of table LTCALLS	6-18
Public-switched network	6-22
Tie line	6-23
Foreign exchange lines	6-24
Typical usage of RLT	6-25
Results of invoking RLT	6-26
RLT overview	6-27
Messaging sequence for RLT with Call Forward	6-29

- Messaging sequence for RLT with Call Forward, No Answer 6-30
- Messaging sequence for RLT with Call Transfer 6-31
- RLT not allowed scenario 6-34
- RLT scenario with Bridge Failure 6-35
- Sample RLT entry in TRKGRP table 6-36
- Service Identifier Routing on an FX 6-37
- Table flow for Service Identifier (SID) Routing 6-38
- Table flow for (SID) routing with sizing 6-38
- Table flow for (SID) routing with or without sizing 6-38
- Example of table ISAXLA 6-39
- Table flow for Call Forward/Interface Busy 6-45
- MAP example for table DNROUTE 6-50
- MAP example for table CFIBDATA 6-51
- SERVORD example for Call Forward/Interface Busy in prompt mode 6-54
- SERVORD example for Call Forward/Interface Busy in no-prompt mode 6-55
- MAP example for table LTDATA 6-60
- Example of circular hunt data in tables IBNRTE and SUPERTKG 6-66
- Example of table entries for CHCL and SG\_CWCTH combination 6-71
- Representation of the route selection process when CHCL and SG\_CWCTH are datafilled 6-72
- Example of table entries for CHCCL and SG\_CCWCTH combination 6-73
- Representation of the route selection process when CHCCL and SG\_CCWCTH are datafilled 6-74
- Example of table entries for CHCL and SG\_CCWCTH combination 6-75
- Example of table entries for CHCCL and SG\_CWCTH combination 6-76
- Example of table TRKGRP entries for the GRP\_CWCTH algorithm 6-76
- Representation of the route selection process when GRP\_CWCTH is datafilled in table TRKGRP 6-77
- Representation of the route selection process when GRP\_CCWCTH is datafilled in table TRKGRP 6-78
- Representation of the route selection process when GRP\_CCWCTH is datafilled in table TRKGRP 6-79
- Table flow for ISP Even Call Distribution (clockwise circular hunting) 6-80
- Table flow for ISP Even Call Distribution (clockwise circular hunting) 6-81
- MAP display example for table TRKGRP 6-86
- MAP display example for tables HNPACONT.RTEREF, FNPACONT.RTEREF, AC RTE, PXRTE, CRTE, FARTE, OFCRTE, FTRTE, and NSCRTE 6-90
- MAP display example for tables OFRT, OFRT2, OFR3, OFR4 6-90
- MAP display example for IBN routing tables 6-92
- TRAVER output example for ISP Even Call Distribution 6-94
- Originating PRI call incoming to the DMS-100 switch 6-98
- Originating PRI call incoming to the DMS-100 switch 6-100
- Table flow for Networked ACD on PRA 6-101
- MAP example for table TCAPTRID 6-105
- MAP example for table REMNACD 6-106
- MAP example for table NACDGRP 6-108
- MAP display example of table TRKSGRP 6-112
- Table flow for PRI: Base MWI Control Using NI-PRI 6-115
- Call code 183 6-124
- MAP example for table LTDATA, datatype SERV, option SHPRN 6-127

---

MAP example for table LTDATA, datatype SERV, option MWIC	6-127
MAP display example for table LTCALLS for PRI: Base MWI Control Using NI-PRI for the NCAS option	6-129
MAP display example for table SVPRIGRP for PRI: Base MWI Control Using NI-PRI with the SHPRN option	6-130
MAP display example for table MSRTAB	6-131
MAP example for table AMAOPTS	6-132
PRI Base Service	6-133
Table flow for PRI Base Service	6-136
MAP display example for table LTDATA	6-139
MAP display example for table PADDATA	6-142
MAP display example for table TRKGRP	6-146
MAP display example for table LTCINV	6-148
MAP display example for table CARRMTC	6-152
MAP display example for table LTCPSINV	6-154
MAP display example for table TRKSGRP	6-160
MAP display example for table TRKMEM	6-162
MAP display example for table LTGRP	6-163
MAP display example for table PRIPROF	6-165
MAP display example for table LTDEF	6-168
MAP display example for table LTMAP	6-170
Example of table LTCALLS	6-174
PRI originations and terminations	6-176
PRI call originations	6-179
PRI call terminations	6-185
Table flow for PRI Bearer Capability Routing originations (private call)	6-188
Table flow for PRI Capability Routing originations (public call)	6-189
Table flow for PRI Bearer Capability Routing terminations (private call)	6-194
Table flow for PRI Bearer Capability Routing terminations (public call)	6-196
MAP display example for table BCDEF	6-203
MAP display example for table TRKGRP	6-205
MAP display example for table RCNAME	6-206
MAP display example for table IBNRTE	6-209
MAP display example for table IBNRTE	6-209
MAP display example for table OFRT or RTEREF	6-213
MAP display example for table OFRT or RTEREF	6-213
MAP display example for table IBNMAP, OFRTMAP, or RTEMAP	6-214
XLAMAP selectors	6-215
MAP display example for table XLAMAP	6-217
PXLAMAP selectors	6-219
MAP display example for table PXLAMAP	6-221
MAP display example for table IBNXLA	6-223
MAP display example for table LTCALLS	6-225
MAP display example for table TRKRCSEL	6-226
MAP display example for table RTECHAR	6-229
TRAVER output example for PRI Bearer Capability Routing private terminating call	6-231
TRAVER output example for PRI Bearer Capability Routing public terminating call	6-233
TRAVER output example for PRI Bearer Capability Routing private originating call	6-236

TRAVER output example for PRI Bearer Capability Routing public originating call 6-239

TRAVER output example for PRI Bearer Capability Routing public originating call 6-242

Table flow for incoming PRI call routing. 6-250

Table flow and translations for an incoming PRI call using table ISXLA 6-251

Table flow and translations for an outgoing PRI call 6-252

Table flow for PRI Call Routing 6-253

MAP display example for table LTCALLS 6-258

MAP display example for table LTDATA 6-260

TRAVER output example for PRI Call Routing 6-265

TRAVER OUTPUT example for PRI Call Routing 6-267

TRAVER output example for PRI Call Routing 6-269

TRAVER output example for PRI Call Routing 6-271

TRAVER output example for PRI Call Routing (Sheet 1 of 2) 6-272

TRAVER output example for PRI Call Routing (Sheet 2 of 2) 6-273

TRAVER output example for PRI Call Routing (Sheet 1 of 2) 6-274

TRAVER output example for PRI Call Routing (Sheet 2 of 2) 6-275

TRAVER output example for PRI Call Routing 6-276

TRAVER output example for PRI Call Routing 6-278

TRAVER output example for PRI Call Routing 6-280

TRAVER output example for PRI Call Routing 6-282

TRAVER output example for PRI Call Routing 6-284

TRAVER output example for PRI Call Routing 6-286

TRAVER output example for PRI Call Routing 6-288

TRAVER output example for PRI Call Routing 6-290

TRAVER output example for PRI Call Routing 6-292

TRAVER output example for PRI Call Routing 6-294

TRAVER output example for PRI Call Routing 6-296

TRAVER output example for PRI Call Routing 6-297

Call screening and redirected number screening 6-301

RN editing and screening functionality 6-302

RN editing and screening functionality 6-303

RN editing and screening functionality 6-304

CGN editing and screening functionality (NI variant) 6-305

CGN editing and screening functionality (NI variant) 6-306

CGN editing and screening functionality (NI variant) 6-307

Billing number determination flow 6-308

Redirecting number delivery flowchart 6-309

Redirecting number privacy 6-310

Table flow for PRI Call Screening 6-312

Map display example for table LTDEF 6-315

MAP display example of table LTDATA 6-319

MAP display example of table DNSCRN 6-320

Operation flow for Calling Line Identification Blocking at the originating exchange 6-323

Operating flow for Calling Line Identification Blocking at the terminating exchange 6-324

MAP display example for table LTDATA 6-327

MAP display example for table LTCALLS 6-329

Table flow for PRI Calling Name Delivery 6-334

---

MAP display example for table LTDATA 6-337  
 MAP display example for table CUSTNTWK 6-337  
 MAP display example for table LTCALLS 6-341  
 MAP display example for table ISDNPROT 6-347  
 Table flow for PRI Hotel/Motel/SCOCS 6-350  
 MAO display example for table TKGRP 6-353  
 MAP display example for table LTDEF 6-357  
 MAP display example for table LTCALLS 6-360  
 MAP display example for table ISAXLA 6-362  
 MAP display example for table VIRTGRPS 6-364  
 TRAVER output example for PRI Hotel/Motel/SCOCS–hotel/motel example 6-365  
 TRAVER output example for PRI Hotel/Motel/SCOCS–SCOCS example 6-366  
 MAP display example for table LTDATA 6-369  
 SMDI overview 6-371  
 Routing TCAP messages thorough table MSGRTE 6-372  
 MWI routing using table MSGRTE 6-373  
 MAP display example for table NETNAMES 6-375  
 MAP display example for table MSGRTE 6-378  
 Operation flow for PRI Network Name Delivery at the originating exchange 6-381  
 Operation flow for PRI Network Name Delivery at the terminating exchange 6-382  
 MAP display example for table NETNAMES 6-385  
 MAP display example for table CUSTNTWK 6-387  
 Routing TCAP messages thorough table MSGRTE 6-390  
 MWI routing using table MSGRTE 6-391  
 MAP display example for table NETNAMES 6-394  
 MAP display example for table CUSTNTWK 6-396  
 MAP display example for table MSGRTE 6-398  
 Example of a SUSP I-CNAM AMA record–voice call 6-404  
 Example of a SUSP I-CNAM AMA record–data call 6-404  
 MAP display example for table LTDATA 6-407  
 Example of PRI Two B-channel transfer 6-410  
 Table flow for PRI Two B-channel Transfer 6-412  
 MAP display example of table SVPRIGRP 6-416  
 MAP display example of table LTDEF 6-419  
 MAP display example for table LTDATA 6-420  
 Table flow for PRI with Semipermanent Packet 6-423  
 Table flow for PRI with Semipermanent Packet (continued) 6-424  
 MAP display example for table TRKSGRP 6-431  
 MAP display example for table LTMAP 6-435  
 SPMS indexing hierarchy 7-3  
 ISDN PRI MAP sublevels 11-2  
 PM level commands 11-11  
 TRKS-level commands 11-12  
 TRKS level commands 11-13  
 Error message display 11-17  
 PRI hardware model 12-5  
 Call processing model 12-6  
 DTA access points - monitoring PRI D channel 12-29  
 Example >traver tr pratest2 6753002 b 15-2  
 PMDEBUG data 15-3  
 Example >traver tr pratest2 n cdn e164 6753002 pvt 0 b 15-4

Example >traver tr pratest2 n cdn e164 1 6753002 prvt 0 b 15-6  
Example DEBEBUG data 15-7

---

## Tables

Document layer number table	xxvi
Document key number table	xxviii
Training courses	xxxii
Bearer capability information element	2-5
ISDN PRI cards	2-12
Other hardware fault conditions	2-16
Example of datafill for option TCAP_CNAM in table LTDATA	3-6
Sample datafill in the OFCENG table	3-6
Sample datafill in the OFCVAR table	3-7
I-CNAM action based on ISUP CGN PI	3-10
ISDN PRI feature availability	3-13
Call-by-call and integrated service access	3-15
XPM card list	5-2
XPM capacity	5-3
PRI pin-outs	5-4
Description of table PMLOADS	5-6
Description of table CARRMTC	5-7
Description of table LTCINV	5-8
Description of table LTCPSINV	5-10
Trunk tables	6-3
Hardware tables	6-3
Associated tables	6-4
Description of table STDPRTCT:STDPRT	6-6
Description of table VIRTGRPS	6-7
Description of table HNPACONT:RTEREF	6-11
Description of table HNPACONT:HNPACODE	6-13
Description of table LINEATTR	6-14
Description of table LTCALLS	6-18
Call by call and integrated service access	6-24
Description of table ISAXLA	6-39
Datafill example for Call Forward/Interface Busy	6-46
Datafill requirements for Call Forward/Interface Busy	6-48
Datafill related to table DNROUTE	6-49
Error messages for table DNROUTE	6-50
Datafill related to table CFIBDATA	6-51
Error messages for table CFIBDATA	6-52
SERVORD prompts for Call Forward/Interface Busy	6-52
Datafill requirements for E911 Preferred DN	6-60
Datafill related to table LTDATA	6-60
Field descriptions for table TRKGRP—subfield for selection sequence	6-64
Description of fields in table IBNRTE	6-65
Recommended selection algorithms	6-70
Datafill example for ISP Even Call Distribution (clockwise circular hunting)	6-80
Datafill example for ISP Even Call Distribution (counterclockwise circular hunting)	6-81
Datafill tables required for ISP Even Call Distribution	6-83
Datafilling table TRKGRP	6-83
Methods of changing SELSEQ value	6-87
Datafilling universal routing tables	6-89

- Warning message for universal routing tables 6-90
- Datafilling IBN routing tables 6-91
- Warning message for universal routing tables 6-92
- Effect of ATTEMPTS value on real time and hit rate 6-93
- Datafill example for Networked ACD on PRA 6-102
- Datafill requirements for Networked ACD on PRA 6-103
- Datafilling table REMNACD 6-106
- Datafilling table NACDGRP 6-107
- Datafill tables required for PRI Backup D-channel 6-110
- Datafilling table TRKSGRP 6-110
- Datafill example for PRI: Base MWI Control Using NI-PRI 6-116
- Module code 072 6-124
- Structure code 0690 6-125
- Office parameters used by PRI: Base MWI Control Using NI-PRI 6-125
- Datafill requirements for PRI: Base MWI Control Using NI-PRI 6-126
- Datafill related to table LTDATA 6-126
- Error messages for table LTDATA 6-128
- Datafill related to table LTCALLS 6-128
- Datafill related to table SVPRIGRP 6-129
- Datafill related to table MSRTAB 6-130
- Datafill related to table AMAOPTS 6-131
- Datafill tables required for PRI Base Service 6-138
- Datafilling table CLLI 6-139
- Error message for table CLLI 6-140
- Datafilling table PADDDATA 6-140
- Datafilling table TRKGRP 6-142
- Datafilling table LTCINV 6-147
- Error message for table LTCINV 6-148
- Datafilling table CARRMTC 6-149
- Datafilling table LTCPSINV 6-152
- Datafilling table TRKSGRP 6-154
- Error message for table TRKSGRP 6-160
- Datafilling table TRKMEM 6-161
- Error message for table TRKMEM 6-162
- Datafilling table LTGRP 6-163
- Datafilling table PRIPROF 6-164
- Error message for table PRIPROF 6-166
- Datafilling table LTDEF 6-166
- Error messages for table LTDEF 6-169
- Datafilling table LTMAP 6-169
- Description of table LTCALLS 6-170
- SETUP information elements 6-181
- PRI call types 6-183
- Example datafill used in flowchart originations (private call) 6-190
- Example datafill used in flowchart originations (private call) 6-190
- Example datafill for flowchart originations (public call) 6-191
- Example datafill for flowchart originations (public call) 6-191
- Example datafill for PRI Bearer Capability Routing terminations (private call) 6-197
- Example datafill for PRI Bearer Capability Routing terminations (private call) 6-197
- Example datafill for PRI Bearer Capability Routing terminations (public call) 6-197
- Example datafill for PRI Bearer Capability Routing terminations (public call) 6-198



---

Office parameters used by PRI Bearer Capability Routing	6-200
Datafill tables required for PRI Bearer Capability Routing	6-201
Datafilling table BCDEF	6-202
Datafilling table TRKGRP	6-204
Datafilling table RCNAME	6-205
Datafilling table IBNRTE	6-206
Datafilling table IBNRTE for retranslation	6-208
Datafilling table OFRT	6-210
Datafilling table OFRT	6-212
Datafilling table IBNMAP, OFRTMAP, or RTEMAP	6-214
Datafilling table XLAMAP	6-216
Error messages for table XLAMAP	6-218
Datafilling table PXLAMAP	6-219
Error messages for table PXLAMAP	6-221
Datafilling table IBXLA	6-222
Datafilling table LTCALLS	6-223
Datafilling table TRKRCSEL	6-226
Error messages for table TRKRCSEL	6-227
Datafilling table RTECHAR	6-227
Error messages for table RTECHAR	6-229
Examples of possible transformations	6-247
Examples of possible treatments	6-247
Table datafill examples for PRI Call Routing	6-254
Datafill tables required for PRI Call Routing	6-255
Datafilling table LTCALLS	6-255
Datafilling table LTDATA	6-259
Datafilling table ISAXLA	6-261
Error message for table ISAXLA	6-262
Entries and explanations	6-263
Datafill example for PRI Call Screening	6-313
Error messages for table LTDEF	6-315
Datafilling table LTDATA	6-315
Field descriptions for conditional datafill	6-317
Error messages for table LTDATA	6-319
Datafilling table DNSCRN	6-319
Datafill tables required for PRI Calling Line Identification Blocking	6-325
Datafilling table LTDATA	6-326
Datafilling table LTCALLS	6-327
Datafill used for the flow chart	6-334
Office parameters required for PRI Calling Name Delivery	6-336
Datafill tables required for PRI Calling Name Delivery	6-336
Datafilling table LTDATA	6-336
Datafill tables required for PRI Calling Name Delivery	6-337
Datafill tables required for Equal Access	6-340
Datafilling table LTCALLS	6-340
Datafill tables required for PRI calling Line Identification Blocking	6-344
Datafilling table ISDNPROT	6-345
Error messages for table ISDNPROT	6-347
Table datafill examples for PRI Hotel/Motel SCOCS	6-351
Datafill tables required for PRI Hotel/Motel/SCOCS	6-352
Datafilling table TRKGRP	6-352

- Description of table LTDEF 6-354
- Description of table LTCALLS 6-357
- Field descriptions of table ISAXLA 6-360
- Field descriptions of table VIRTGRPS 6-362
- Datafill tables required for PRI ISDN Treatments 6-368
- Datafilling table LTDATA 6-368
- Datafill tables required for PRI Message Waiting Indicator 6-374
- Datafilling table NETNAMES 6-374
- Datafilling table MSGRTE 6-376
- Error messages for table MSGRTE 6-379
- Datafill tables required for PRI Network Name Delivery 6-384
- Datafilling table NETNAMES 6-384
- Datafilling table CUSTNTWK 6-386
- Datafill tables required for PRI Network Ring Again 6-393
- Datafilling table NETNAMES 6-393
- Datafilling table CUSTNTWK 6-395
- Datafilling table MSGRTE 6-397
- Error messages for table MSGRTE 6-399
- Datafilling table LTDATA 6-405
- Error messages for table LTDATA 6-408
- Example of data in tables used for PRI Two B-channel Transfer 6-412
- Data tables required for PRI Two B-channel Transfer 6-415
- Datafilling table SVPRIGRP 6-416
- Error messages for table SVPRIGRP 6-417
- Datafilling table LTDEF 6-418
- Error messages for table LTDEF 6-419
- Datafilling table LTDATA 6-420
- Error messages for table LTDATA 6-421
- Example of precondition datafill for PRI with Semipermanent Packet 6-425
- DATAFILL EXAMPLE OF PRI with Semipermanent Packet 6-426
- Datafill tables required for PRI with Semipermanent Packet 6-430
- Datafilling table TRKSGRP 6-431
- Error messages for table TRKSGRP 6-432
- Error message for table TRKMEM 6-434
- Datafilling table LTMAP 6-435
- Error message for table LTMAP 6-435
- Directories and modified commands required for PRI with Semipermanent Packet 6-438
- SPMS indexes 7-3
- SPMS indexes of performance ratings 7-4
- Test tools available for network maintenance 7-7
- Recommended routine maintenance procedures 7-8
- Summary of ISDN PRI related logs 8-2
- ISDN PRI service affecting logs 8-7
- ISDN PRI potential service affecting logs 8-8
- ISDN PRI provisioning and engineering information logs 8-10
- ISDN PRI and ISDN PRI related OM groups 9-1
- ISDNOM registers 9-3
- ISDN PRI service affecting OM registers 9-6
- ISDN PRI provisioning and engineering OM registers 9-9
- Menu MAP commands 11-2

Unlisted MAP commands	11-9
DTCI and LTC states	11-14
DS-1 trunk states	11-14
D-channel states	11-16
Descriptions of error messages	11-18
Troubleshooting steps	12-7
Data level commands for testing for line errors	12-10
BERT command sequence	12-10
DS-1 alarm thresholds	12-13
Table categories	12-15
ISA Types	12-16
PRI call states	12-18
PRI global states	12-19
Valid SETUP message response	12-22
DTA commands	12-29
ISDN troubleshooting	13-1
Mapping cause values to treatments	14-1
Mapping treatments to cause values	14-4



---

# About this guide

---

## When to use this guide

This guide is an overview of the software release NA010 for the DMS-100 Integrated Services Digital Network (ISDN) Primary Rate Interface (PRI) product.

This guide is written in response to customer requests to consolidate ISDN information in one document. This guide supplements information published in Northern Telecom publications (NTP) and is not intended to replace NTPs at this time.

This guide is divided into the following parts:

- Part I: Introduction
- Part II: Functional description
- Part III: Planning and engineering
- Part IV: Provisioning
- Part V: Operation, administration, and maintenance

## How to check the version and issue of this document

The version and issue of the document are indicated by numbers, for example, 01.01.

The first two digits indicate the version. The version number increases each time the document is updated to support a new software release. For example, the first release of a document is 01.01. In the *next* software release cycle, the first release of the same document is 02.01.

The second two digits indicate the issue. The issue number increases each time the document is revised but rereleased in the same software release cycle. For example, the second release of a document in the same software release cycle is 01.02.

To determine which version of this document applies to the software in your office and how documentation for your product is organized, check the release

information in *DMS-10 and DMS-100 Family Product Documentation Directory*, 297-8991-001.

## References in this document

Because the Nortel products comprise an extensive amount of existing documentation, it is not possible to reproduce all the operational, maintenance, engineering, and descriptive information already available in the library. Therefore, the *DMS-100 ISDN PRI Service Implementation Guide (SIG)* contains references to existing Nortel (Northern Telecom) documentation to direct the reader to comprehensive information describing products as applicable.

## Documentation numbering conventions

Nortel's DMS documentation is frequently referred to as Northern Telecom publications (NTP). The NTPs follow a specific numbering system, such as

XXX-YYYY-ZZZ

The division number, XXX, indicates the common family of product functionality.

The layer number, YYYY, indicates the product computing module (CM) load (PCL) in the specified switching family. Within the documentation structure, the document layer number depends on the PCL number for the specific software load.

The key number, ZZZ, indicates the type of NTP, according to the specified area for the switch or group number. Group numbers range from 000-899.

Table 1 lists NTP layer numbers and their corresponding PCLs or product names.

**Table 1 Document layer number table (Sheet 1 of 3)**

Document layer number	PCL or product	PCL name or product name
8001	LEC/LECB	U.S. stand-alone DMS-100/200
8011	CDN/CDNB	Canadian stand-alone DMS-100/200
8021	LET/LETB	U.S. DMS-100/200 TOPS Combination
8041	UK/EUR	European DMS-100
8051	ABSM	Advanced Business Services (ABSM=Australia, China, and Cala)

**Table 1 Document layer number table (Sheet 2 of 3)**

<b>Document layer number</b>	<b>PCL or product</b>	<b>PCL name or product name</b>
8061	ABSL	Advanced Business Services (ABSK=IDC only)
8071	ATVB	Canadian stand-alone DMS-100/200 AUTOVON
8081	LATB	North American DMS200
8091	LWW	DMS-100 Wireless
8101	STPBASE	Signaling Transfer Point Base
8111	STPMDR7	Signaling Transfer Point MDR7
8121	STPSEAS STP	Signaling Engineering and Administration System
8201	RLCM/OPM	Remote Line Concentrating Module/Outside Plant Module
8211	OPAC	Outside Plant Access Cabinet
8213	OPAC	International Outside Plant Access Cabinet
8221	RSC	Remote Switching Center
8231	SCM-100S	Subscriber Carrier Module-100S
8241	SCM-100U	Subscriber Carrier Module-100 Urban
8251	SCM-100A	Subscriber Carrier Module-100 Access
8253	SCM-100A	Subscriber Carrier Module-100 Access (MVI-20)
8261	RSCS	Model A Remote Switching Center-SONET Model A (DS1)
8263	SCM-100A	Subscriber Carrier Module-100 Access Maintenance Manual
8271	RSCS Model A	Remote Switching Center-SONET Model A (PCM30)
8281	RSCS Model B	Remote Switching Center-SONET Model B (DSI)
8291	RSCS Model B	Remote Switching Center-SONET Model B (PCM30)

**Table 1 Document layer number table (Sheet 3 of 3)**

Document layer number	PCL or product	PCL name or product name
8301	SCM-100SR	Subscriber Carrier Module-100S Remote
8311	Host XPM	Host Extended Peripheral Module
8321	XPM	Extended Peripheral Module (DSI)
8331	XPM	Extended Peripheral Module (PCM30)
8341	TOPS	Traffic Operator Position System Message Switch
8411	USTOPS	Traffic Operator Position System (Stand-alone U.S.)
8421	CDMTOPS	Traffic Operator Position System (Stand-alone Canadian)
8501	SCP	Service Control Point
8601	DMSG002	DMS Global
8991	PCL common misc.	PCL common and maintenance

Table 2 lists NTP types and their associated key numbers.

**Table 2 Document key number table (Sheet 1 of 2)**

NTP type	Key number
Translations Guide	350
Alarm and Performance Monitoring Procedures	543
Trouble Locating and Clearing Procedures	544
Recovery Procedures	545
Routine Maintenance Procedures	546
Card Replacement Procedures	547
XPM Maintenance Manual (remotes only, layers 8201-8331)	550
Feature Description Manual	801
Peripheral Module Software Release Document	599
Hardware Description Manual (PCL common/misc. only, layer 8991)	805
Service Order Reference Manual	808



**Table 2 Document key number table (Sheet 2 of 2)**

<b>NTP type</b>	<b>Key number</b>
Operational Measurements Reference Manual (all PCLs and XPM)	814
XPM Translations Reference Manual	815
Automatic Message Accounting Bulletin	830
Log Reports Reference Manual	840
Office Parameters Reference Manual	855
Software-to-Data Cross Reference	856

In addition to NTPs, Nortel provides System Engineering Bulletins (SEB) and System Engineering Alerts (SEA) that contain information on engineering the ISDN call processing functions. These documents present performance engineering rules, existing or new, in a simplified, user-oriented format. The information in these documents is product specific, PCL specific, or both.

The *DMS-10 and DMS-100 Family Product Documentation Directory, 297-8991-001*, is an excellent source listing of current NTPs for the DMS Family of switches.

## What precautionary messages mean

The types of precautionary messages used in Nortel documents include attention boxes and danger, warning, and caution messages.

An attention box identifies information that is necessary for the proper performance of a procedure or task or the correct interpretation of information or data. Danger, warning, and caution messages indicate possible risks.

Examples of precautionary message types follow:

**ATTENTION** Information needed to perform a task.

### **ATTENTION**

If the unused DS-3 ports are not deprovisioned before a DS-I/VT Mapper is installed, the DS-1 traffic will not be carried through the DS-I/VT Mapper, even though the DS-1/VT Mapper is properly provisioned.

**DANGER** Possibility of personal injury



**DANGER**

**Risk of electrocution**

Do not open the front panel of the inverter unless fuses F1, F2, and F3 have been removed. The inverter contains high-voltage line. Until the fuses are removed, the high-voltage lines are active, and you risk being electrocuted.

**WARNING** Possibility of equipment damage



**DANGER**

**Damage to the backplane connector pins**

Align the card before seating it, to avoid bending the backplane connector pins. Use light thumb pressure to align the card with the connectors. Next, use the levers on the card to seat the card into the connectors.

**CAUTION** Possibility of service interruption or degradation.



**CAUTION**

**Possible loss of service**

Before continuing, confirm that you are removing the card from the inactive unit of the peripheral module. Subscriber service will be lost if you remove a card from the active unit.

## How commands, parameters, and responses are represented

Commands, parameters, and responses in this document conform to the following conventions.

### Input prompt (>)

An input prompt (>) indicates that the information that follows is a command:

>BSY

---

## Commands and fixed parameters

Commands and fixed parameters that are entered at a MAP terminal are shown in uppercase letters:

```
>BSY CTRL
```

## Variables

Variables are shown in lowercase letters:

```
>BSY CTRL ctrl no
```

The letters or numbers that the variable represents must be entered. Each variable is explained in a list that follows the command string.

## Responses

Responses correspond to the MAP display and are shown in a different type:

```
FP 3 Busy CTRL 0: Command request has been submitted.  
FP 3 Busy CTRL 0: Command passed.
```

The following excerpt from a procedure shows the command syntax used in this document:

### ***At the current location***

- 1 To manually busy the CTRL on the inactive plane, type  

```
>BSY CTRL ctrl_no
```

and press the Enter key  
*where*  
ctrl\_no is the number of the CTRL (0 or 1)

```
Example of a MAP response:  
FP 3 Busy CTRL 0: Command request has  
been submitted.  
FP 3 Busy CTRL 0: Command passed.
```

## Audience

This guide is intended for all audiences. However, information in some sections may be pertinent to specific audiences. For example, operating company management and sales agents may want to focus on the Overview, Applications, and Terminals sections. Operating company engineering, installation, and support personnel may want to focus on the technical sections of the document.

## Important notice

ISDN is a technology that requires development of additional skills to implement, operate, and maintain the DMS switch. This guide is designed to

offer the user a quick and comprehensive overview of implementing ISDN. The guide is not a replacement for developing the appropriate level of knowledge within your company. Nortel offers a comprehensive set of documentation and training courses for ISDN on the DMS switch. The following training courses are available through Nortel's training center.

**Table 3 Training courses**

<b>Course number</b>	<b>Title</b>
0170	Introduction to ISDN Computer-Based Training (CBT)
3400	Introduction to DMS SuperNode Translations (CBT)
0386	ISDN Basic Rate Interface Maintenance and Testing
0471	ISDN Engineering and Provisioning
0472	ISDN Translations
0476	ISDN Customer Premise Equipment (CPE)
0491	ISDN Advanced Testing and Protocols
7002	ISDN PRI Translations

A key part of ISDN includes customer premise equipment (CPE). There is a lot of very good CPE publicly available; however, some CPE may not be compatible with the DMS switch. Verify that the CPE you purchase is National ISDN compliant.

---

# Part I

## Introduction

---

Part I: “Introduction” contains the following chapters:

- ISDN PRI overview
- Primary rate interface hardware components
- Primary rate interface software components



---

# 1 ISDN PRI overview

---

## Introduction to ISDN

Integrated services digital network (ISDN) is a standard, all digital, technology. ISDN allows for simultaneous, integrated voice and data capability over two-wire digital loops and four-wire digital trunks. These loops and trunks can access circuit-switched voice and data networks and network services databases.

For effective deployment, ISDN providers conform to National ISDN. National ISDN refers to the set of ISDN standards that apply to North America. The International Telephone and Telegraph Consultative Committee (CCITT), now known as the International Telecommunications Union (ITU), is a United Nations organization that coordinates and standardizes international telecommunications. ITU led the original effort that produced the initial, basic guidelines for implementing ISDN.

In the early 1990s, an industry-wide effort to establish specific ISDN implementation standards (which did not include ISDN PRI) produced National ISDN 1 (NI-1). These standards enable subscribers to know that the equipment and software products they buy are compatible with an ISDN switch. More recently, the industry has selected more complete ISDN standards called National ISDN 2 (NI-2), which builds on the base established by NI-1. National ISDN 3 (NI-3), further standardizes the interface protocols and services and expands functionality.

National ISDN indicates to subscribers, manufacturers, and network providers that ISDN is ready to become the advanced telecommunications infrastructure for North America. National ISDN is important to everyone who sells communications products because it provides for the following:

- a wider access to high speed data communications
- a new market for high-performance customer premises equipment (CPE) and networks
- many new applications

National ISDN commitments address the following three major areas:

- ISDN user equipment, such as computers, data terminals, and telephones, and services that they use
- standard operating company procedures and systems for the operation, administration, and maintenance of ISDN services and equipment
- standard communications among ISDN capable switches to extend ISDN services throughout the public-switched network

These standards enable the operating companies to market a practical ISDN service, and the subscribers to be sure of stable terminals and services.

National ISDN gives switch and CPE manufacturers a standard ISDN technology base for future product development. Network providers can install ISDN in their multi-vendor networks and market a portfolio of ISDN services nationwide. National ISDN gives users access to a predefined set of ISDN features from virtually any operating company switch. There is also a selection of CPE and software from many different suppliers that best matches their individual needs.

Although National ISDN standardizes the basic elements of ISDN, there is still room for innovation and value-added services. Network providers can invent a new ISDN service, or a computer manufacturer can enhance its ISDN products. Over time, many of these enhanced services make their way into the standard feature set. For example, Nortel installs more than 200 centrex services on the standard ISDN line, using only those procedures and protocols defined by National ISDN. This approach allows for a standard technology platform with incentives and opportunities to add value.

The real ISDN revolution is that ISDN is available all across North America with a standard set of standardized services. This ISDN standardization frees subscribers from the premium cost of proprietary solutions.

National ISDN has energized the ISDN industry, stimulating demand for ISDN services and promoting the supply of ISDN hardware and software. Previously, the lack of ISDN telephones, data terminals, and compatible software had a dampening effect on the deployment of ISDN throughout the telecommunications industry. Telephone operating companies were reluctant to market ISDN without a wide choice of terminals and a standard feature set. Hardware and software manufacturers were reluctant to develop products until ISDN was more widely marketed. National ISDN continues to drive widespread ISDN installation and development.

There are two types of ISDN interfaces offered in North America: primary rate interface (PRI) and basic rate interface (BRI). This documentation only addresses ISDN PRI.



---

## ISDN PRI overview

PRI carries 23B+D channels over a digital DS-1 facility. PRI is used to link private networking facilities, such as private branch exchange (PBX), local area network (LAN) facilities, and host computers with standardized architecture. This architecture acts as the bridge between private switching equipment and the public network. The following gives a brief overview of the Nortel ISDN PRI product.

### ISDN PRI background

National ISDN PRI was not defined until NI-2 (some ten years after the initial PRI development). During that period, individual companies developed and used proprietary versions of PRI. Different versions of PRI existed, which required customer premises equipment (CPE) to support several different variants of PRI. To overcome communication problems, companies such as Northern Telecom and AT&T, developed protocol variants to enable their equipment to communicate with PRI versions different from their own. To compare Northern Telecom North American Primary Rate Interface (NTNAPRI) and NI-2, refer to NIS-A211-1 and NI-2 Interface Specification.

Nortel's NI-2 compliant PRI is called National ISDN (NIPRI) and is defined by the NIS-A233-1 Interface Specification. NI-2 PRI is an industry effort to standardize PRI features and protocol. A standard interface has the advantage of more CPE being able to invest in research and development required to build a reliable interface. NI-2 PRI is the industry's attempt to standardize PRI at a minimum feature level. This initial release supports a limited number of features. The NA009 release of NIPRI creates the fully featured PRI that is in the proprietary protocol, plus additional features.

### ISDN PRI description

ISDN PRI is an ISDN trunking technology in use as an interface between a switching center and CPE. PRI offers multiple advantages over other trunking technologies in the use. The following list describes some of these advantages.

- A single PRI trunk group serves different types of traffic. This is a more efficient use of trunk facilities over the allocation of one trunk group for each call type.
- PRI improves service through provisioning of features, such as Network Name Display, Network Ring Again, and other custom features to subscribers on different switches. End-to-end name and number delivery allows centered subscribers to have phone service from multiple locations.
- PRI decreases call setup time and facility use. PRI uses the D-channel for call setup. A B-channel is not allocated if the called line is busy.
- PRI provides inter-switch and network feature functionality, delivers bearer capabilities, and call-by-call trunking. Call-by-call trunking or integrated services access (ISA) uses a group of trunks to serve different

call types, such as private, public, WATS, INWATS, FX, and TIE. Each trunk can serve each of these call types.

Figure 1-1 shows an example of an ISA configuration.

**Figure 1-1 PRI integrated services access (ISA/call-by-call)**

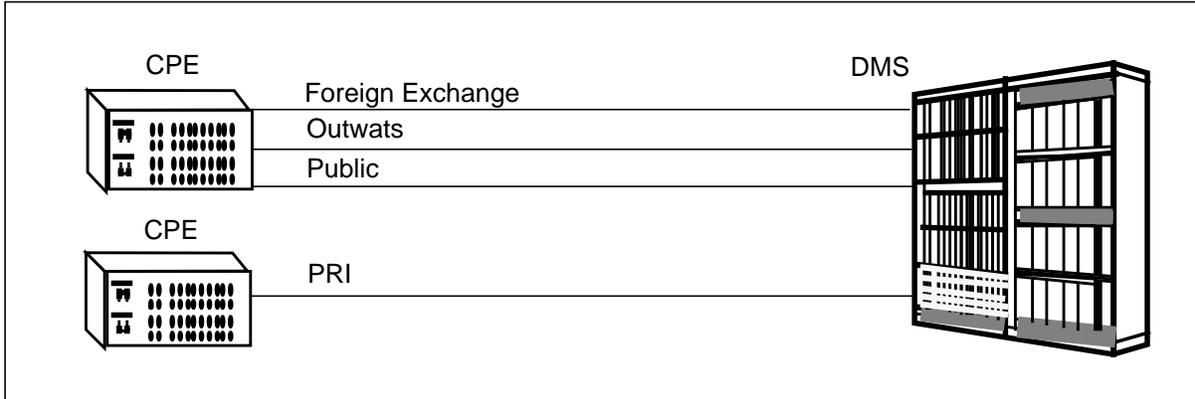

PRI uses out-of-band signaling technologies, referring to its use of a separate channel (D-channel) for call control, and leaving the remaining channels for traffic use. This usage is similar to SS7 in that call setup, calling line ID, and any messaging is out-of-band. The physical interface is a DS-1 carrier. Figure 1-2 illustrates PRI out-of-band messaging.

**Figure 1-2 PRI out-of-band messaging**

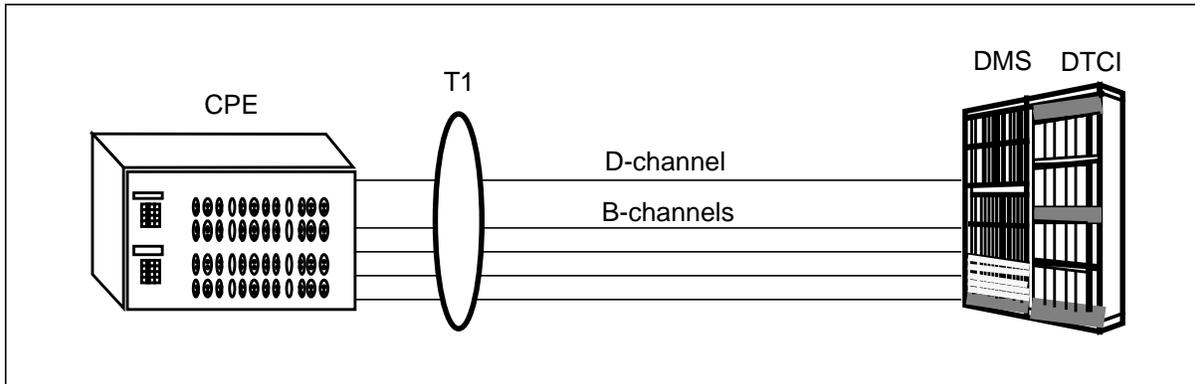

Two configurations for PRI, associated and non-facility associated (NFAS), are also referred to as 23B+D and NFAS, respectively. With facility associated PRI, a D-channel controls each DS1 span individually. With NFAS, the D-channel controls multiple spans. The concept is called nB+D. One D-channel can control as many as 20 DS-1 spans or 479 B-channels. With NFAS, there is also an option for a backup D-channel. Figure 1-3 shows examples of PRI configurations.

Figure 1-3 PRI configurations

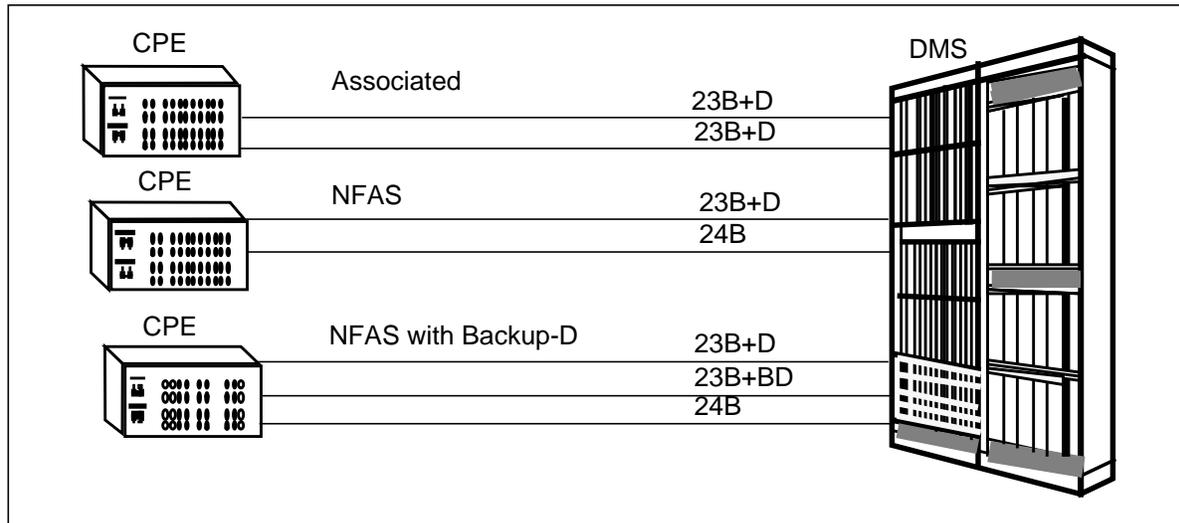

## Applications

Applications fall into one of two categories; the traditional private branch exchange (PBX) and voice connection, or the customer premises equipment (CPE) designed for data for LAN connection and Internet access. All applications have similar datafill. The difference in application is based on the features that are required. A PBX can be set up for all voice and data features, whereas a video router, which is one-way traffic device, only requires DWS and a BC route.

Figure 1-4 shows an illustration of the voice messaging system application.

Figure 1-4 Voice messaging systems application

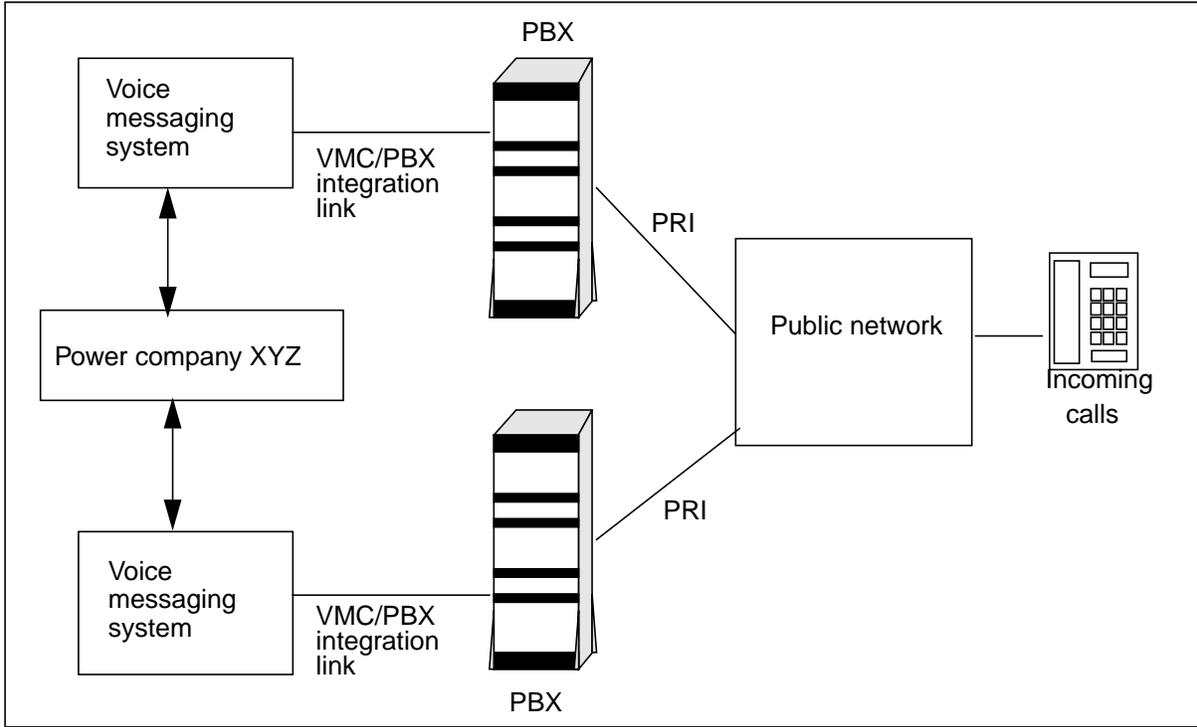

Figure 1-5 shows an illustration of the fax mail application.

Figure 1-5 Fax mail application

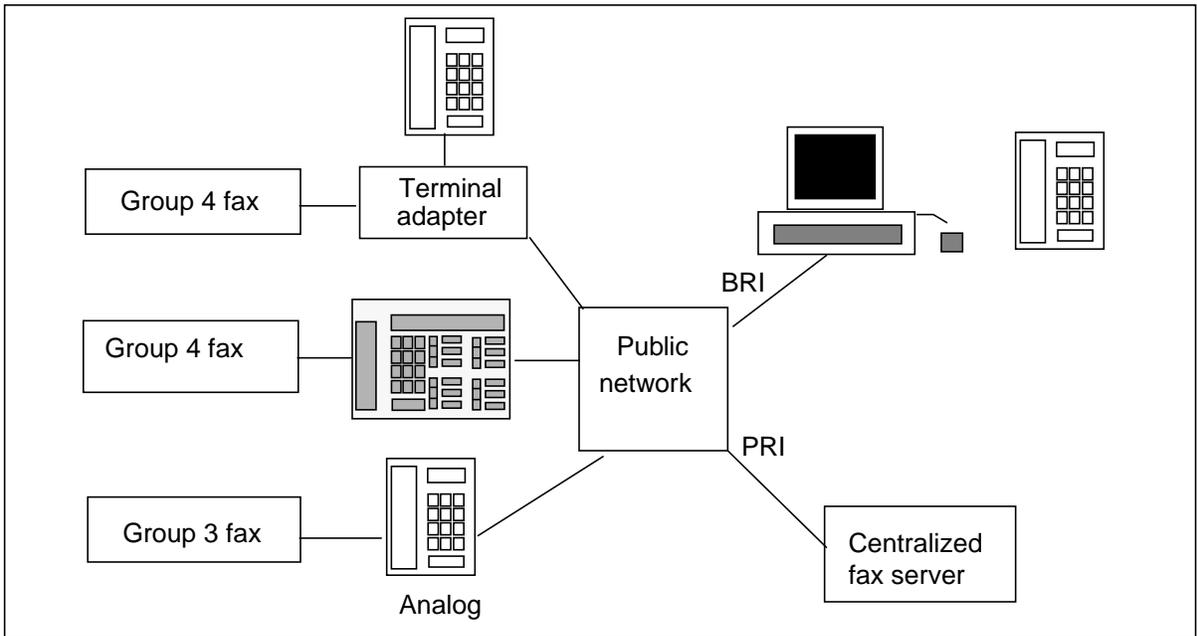

Figure 1-6 shows an illustration of the call center load balancing application.

**Figure 1-6 Call center load balancing application**

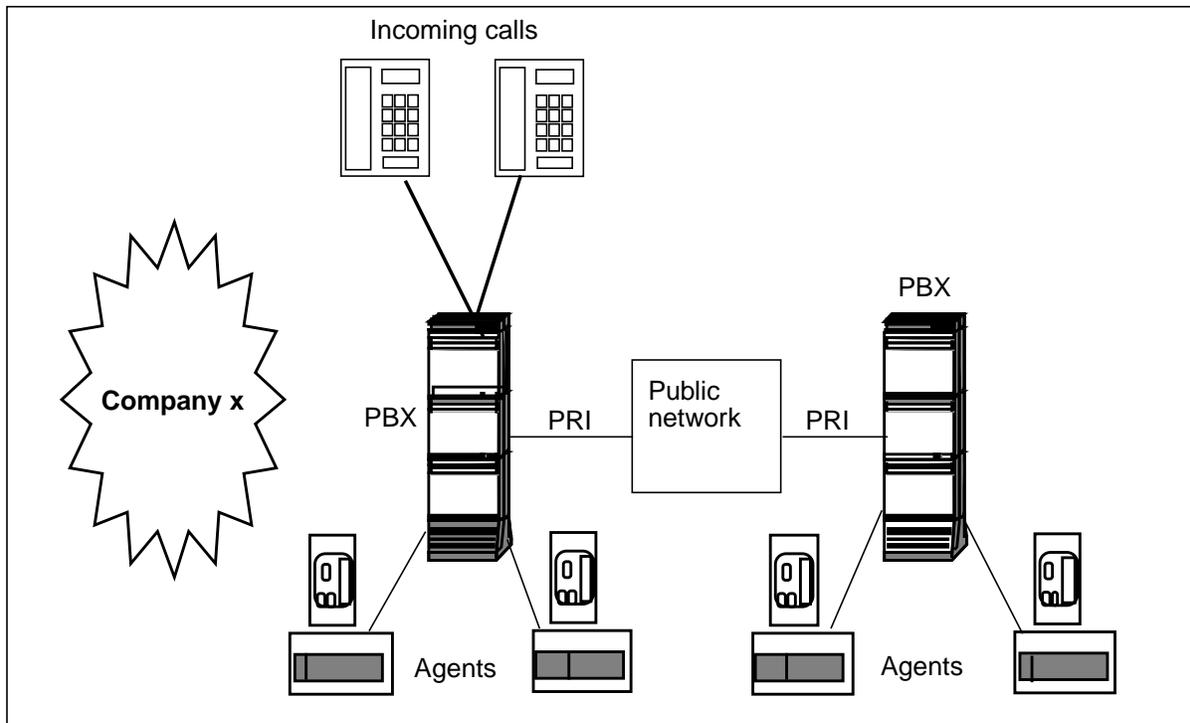

Figure 1-7 shows an illustration of the LAN bridging application. PRI can transmit data at speeds of up to 1.54 Mbps between two interconnected LANs. Using dial-up capabilities, the PRI line connects only the number of B-channels that are needed, eliminating the need for an underutilized high-speed leased line. This capability is important when interconnecting large LANs that have occasional need to transfer large amounts of information while meeting response time limitations.

**Figure 1-7 LAN bridging application**

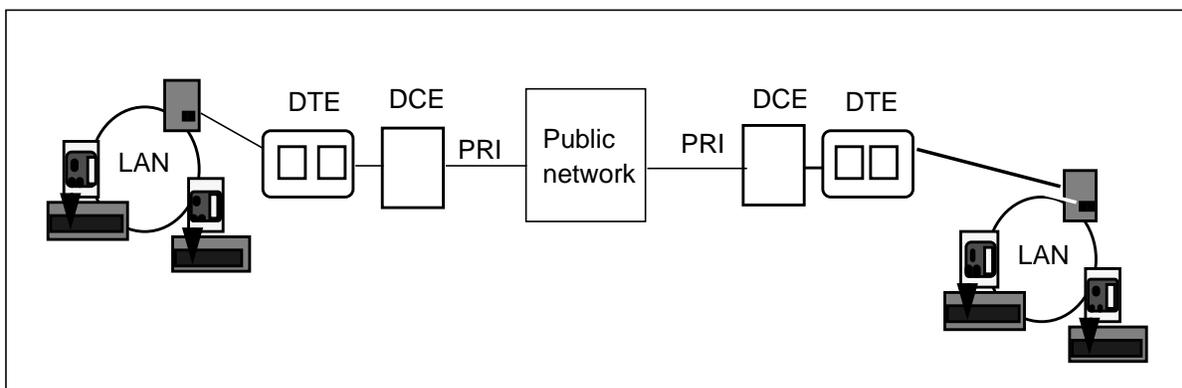

Figure 1-8 shows an illustration of the multi-point bridging application.

**Figure 1-8 Multi-point bridging application**

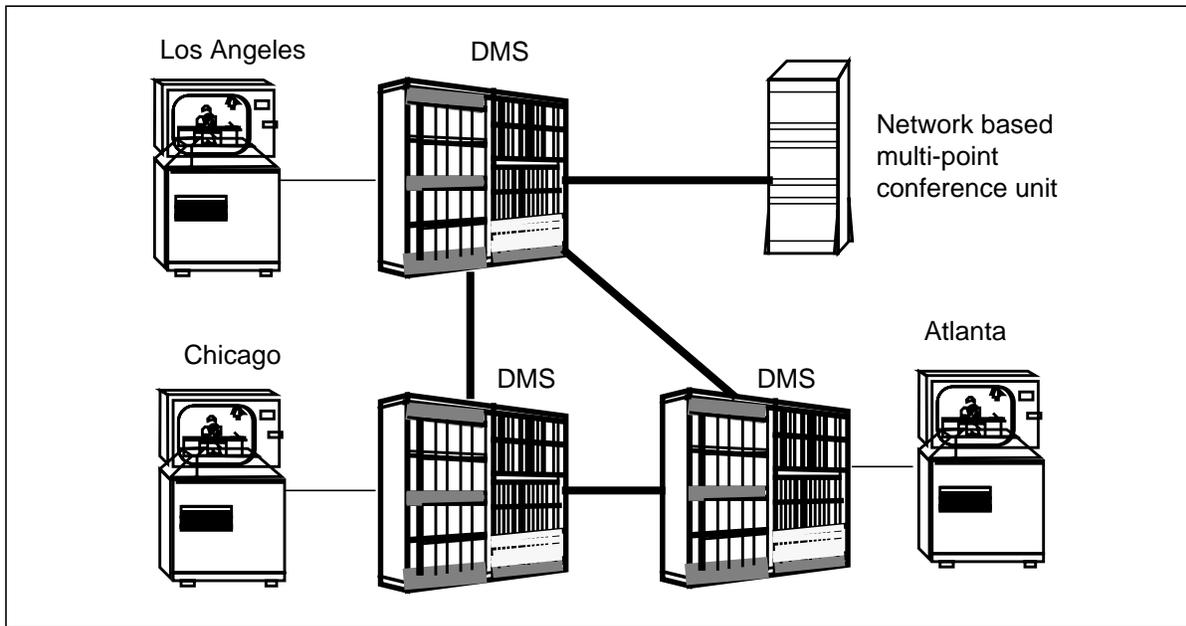

Figure 1-9 shows an illustration of the videoconferencing application. PRI can be used to link video conference systems that support real-time video, audio, and document communications. Employees can reduce travel while still meeting face-to-face. These links are established only as required., representing tangible cost savings over leased lines. Figure 10 shows an illustration of the distance learning application.

Figure 1-9 Videoconferencing application

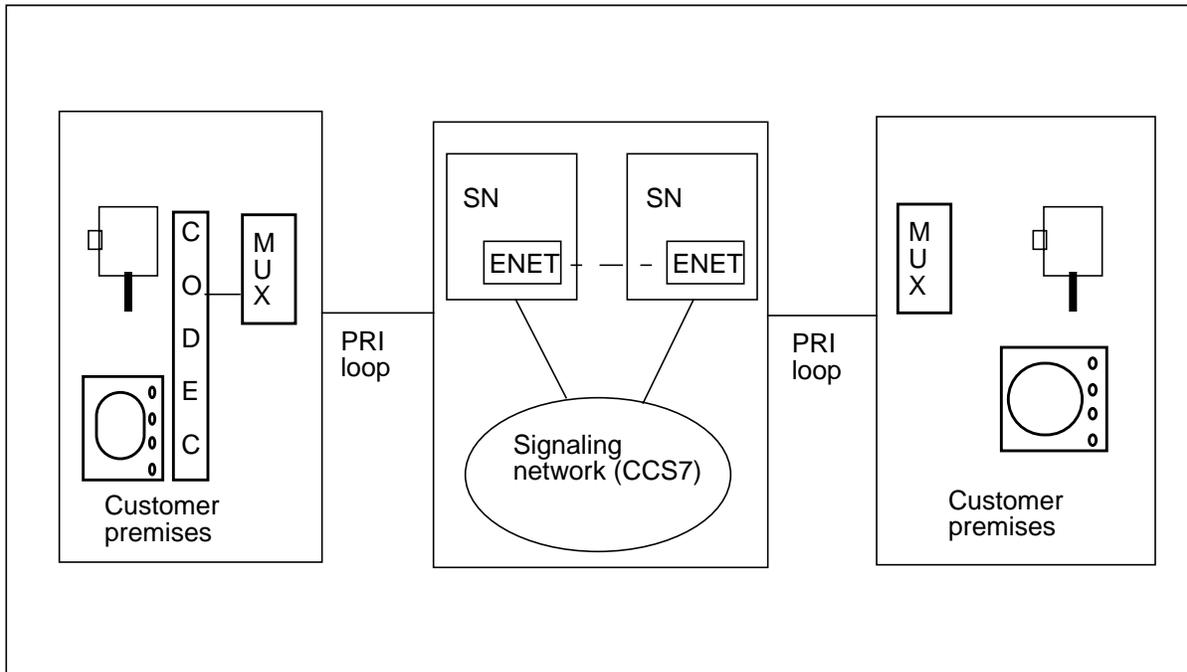

Figure 1-10 shows an example of a distance learning application.

Figure 1-10 Distance learning application

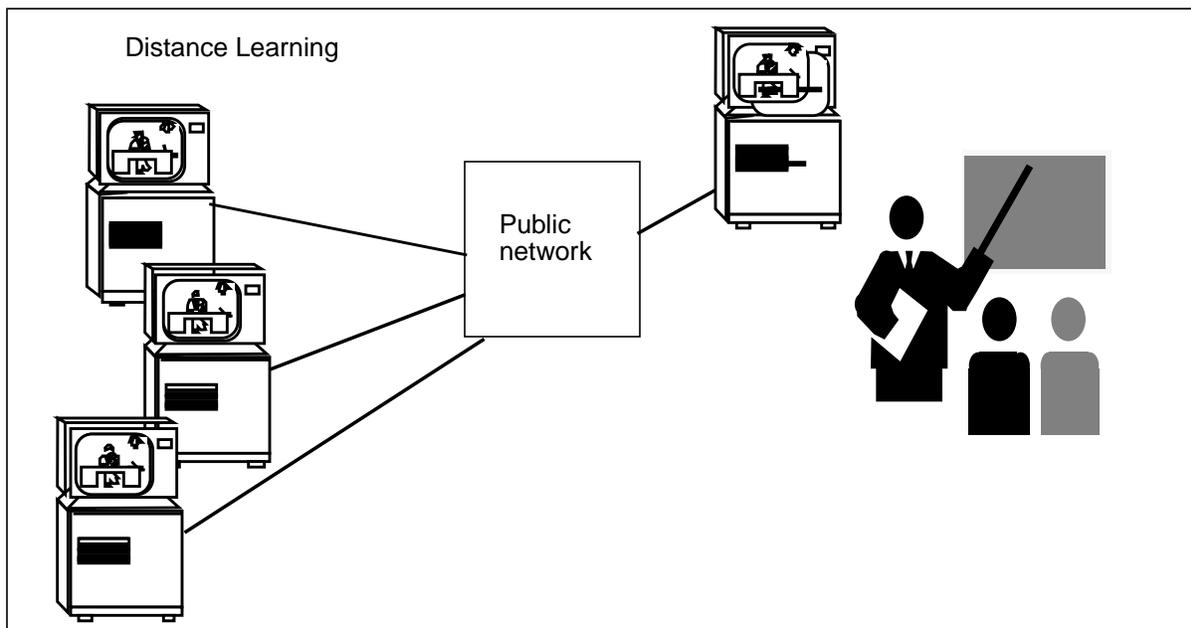

Figure 1-11 shows an example of the PRI Internet access application. PRI is attractive for connection to internet service providers (ISP) because of its high speed and adaptable bandwidth. PRI technology is more efficient for handling the traffic patterns associated with ISPs than traditional alternatives.

**Figure 1-11 PRI Internet access application**

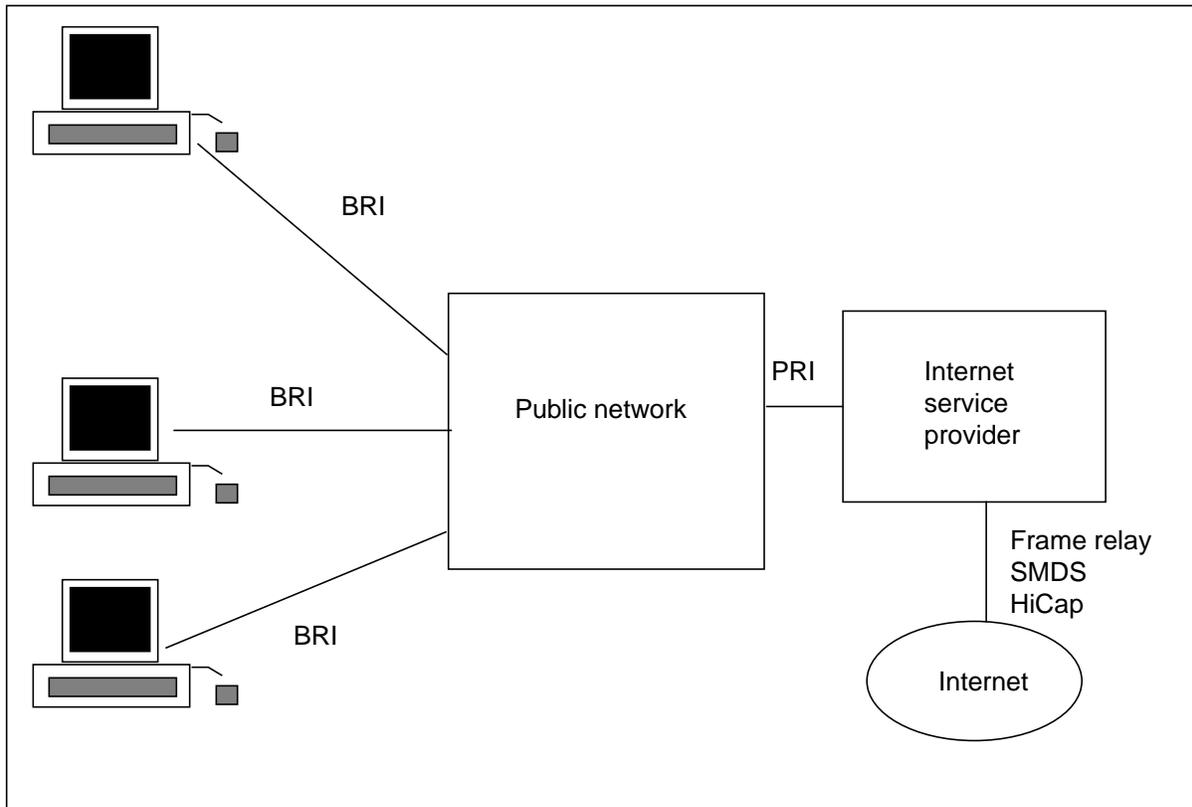

Figure 1-12 shows an example of the high-speed data transfer application. In multi-location environments (PBX, centrex), this application makes it easier for employees at different sites to work together. By combining PRI between sites and ISDN to the desktop for voice and data integration, users can exchange draft memos, spreadsheets, and presentations without the cost and inconvenience of faxes. Maintaining work in an electronic format makes it easier to make changes and customize results. With ISDN's bandwidth and low error rates, files can be transferred quickly.



Figure 1-12 High speed data transfer application

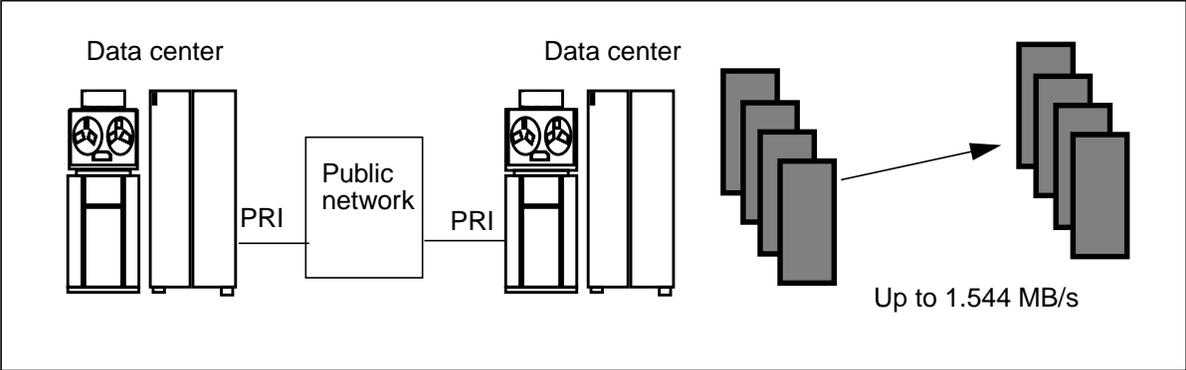
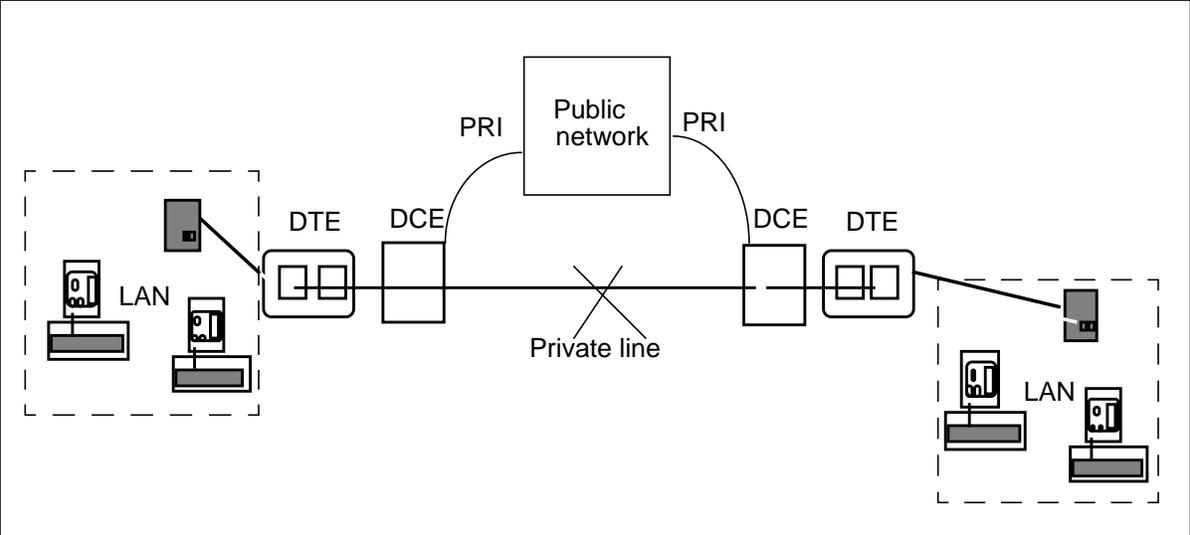

Figure 1-13 shows an example of the private line backup/augmentation application.

Figure 1-13 Private line backup/augmentation application





---

## 2 ISDN PRI hardware components

---

This chapter describes the hardware required for ISDN PRI service. It also describes shelf layout and card requirements.

### ISDN PRI equipment

The following equipment is required to provide PRI circuit-switched voice and data services:

- DMS-core
- DMS-bus
- circuit-switched network
- ISDN digital trunk controller (DTCI), or line trunk controller (LTC) equipped for ISDN (not shown)
- DS-1 link
- customer CPE

Both the DTCI and LTC are extended multiprocessor system (XMS)-based peripheral modules (XPM) and perform the following functions:

- D-channel handling and processing
- call processing for all types of lines (ISDN, EBS, POTS, and Datapath)
- maintenance and diagnostics
- ISDN signal processing

The CPE performs the network termination function. The CPE also converts the non-ISDN protocols of the user (subscriber lines, telephone sets, and personal computers) to the ISDN protocols required for the network

### XPM hardware configuration

Figure 2-1 shows the high-level XPM hardware configuration in use for ISDN XPMs.

**Figure 2-1 XPM hardware configuration**

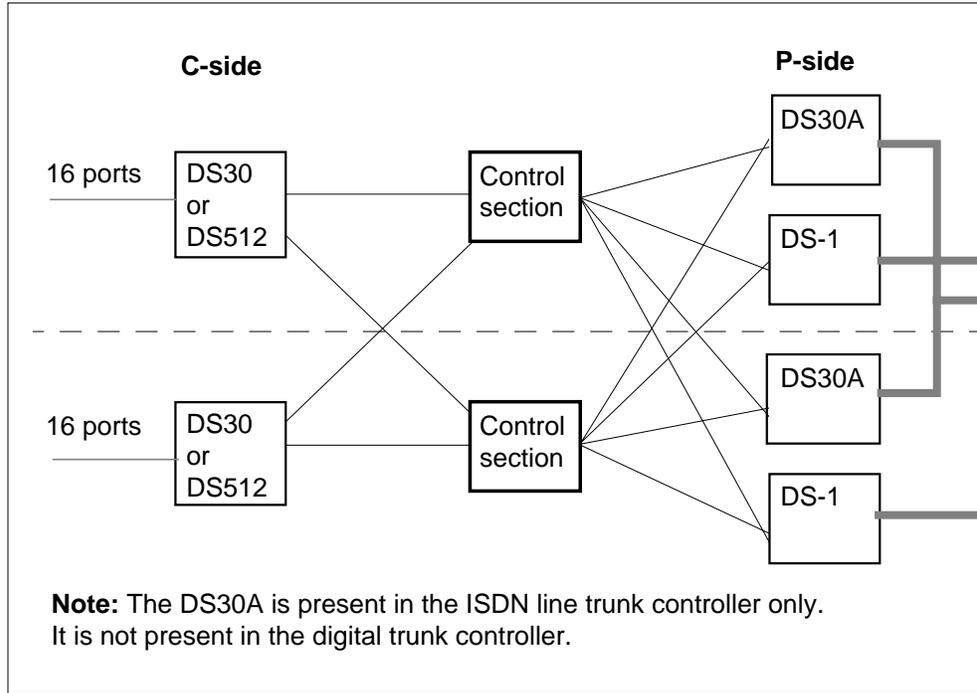

**Peripheral side interface**

The peripheral side (P-side) XPM connections use DS-1 or DS30A links. Two DS-1 links are on each DS-1 card (a total of 48 DS-0s per card). DS-1 cards connect internally to the time switch by DS60 links. S30A links are used to connect the peripherals for lines.

The two units of the XPM operate in hot-standby mode, which means that one unit is active and the other unit is on standby. The active unit handles all call processing, while the standby unit takes over if a fault occurs in the active unit.

**PRI channels**

DS-0 channels provide PRI channels on standard 1.544-Mbit/s DS-1 links. A single DS-1 can support a combination of PRI channels and a per-trunk signaling (PTS) or A/B trunks is known as an integrated trunk access (ITA) configuration. Figure 2-2 shows two DS-1 links, one of which is configured for ITA. The first DS-1 link is configured for PRI only with one D-channel and 23 B-channels. For the second DS-1 link, B-channels 1 to 21 are set up for ISDN PRI service, and B-channels 22 to 24 are set up for PTS.

Figure 2-2 PRI channels

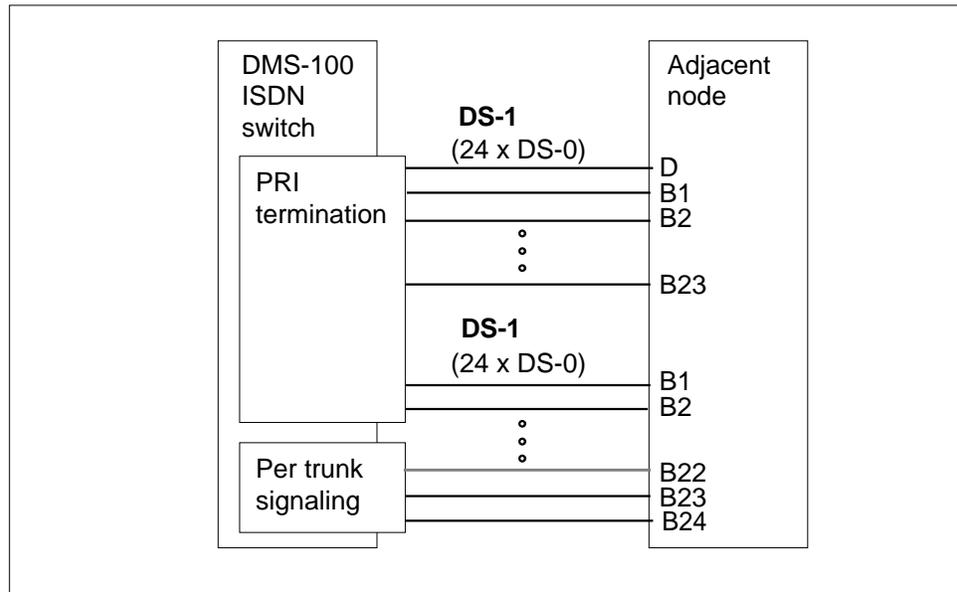

Figure 2-2 illustrates the two types of PRI channels:

- D-channels (control channels) for call control
- B-channels (bearer channels) for voice and data transmission

The D-channels and B-channels in use by PRI on one or more DS-1 links are called a PRI trunk group. All channels in a trunk group must operate at the same speed. All channels in a trunk group must terminate on the same XPM in the DMS-100 ISDN node.

### B-channels

B-channels carry circuit-switched voice or data between the DMS-100 switch (or ISDN node) and the adjacent node. B-channels not in use in a PRI DS-1 can datafill as idle, or as PTS A/B bit trunks for non-ISDN use. The ISDN node does not monitor B-channels for signaling. Therefore, subscribers must provide all formatting and protocol processing at the end of each call. See Figure 2-3 for an example of a B-channel data call.

Figure 2-3 B-channel data call example

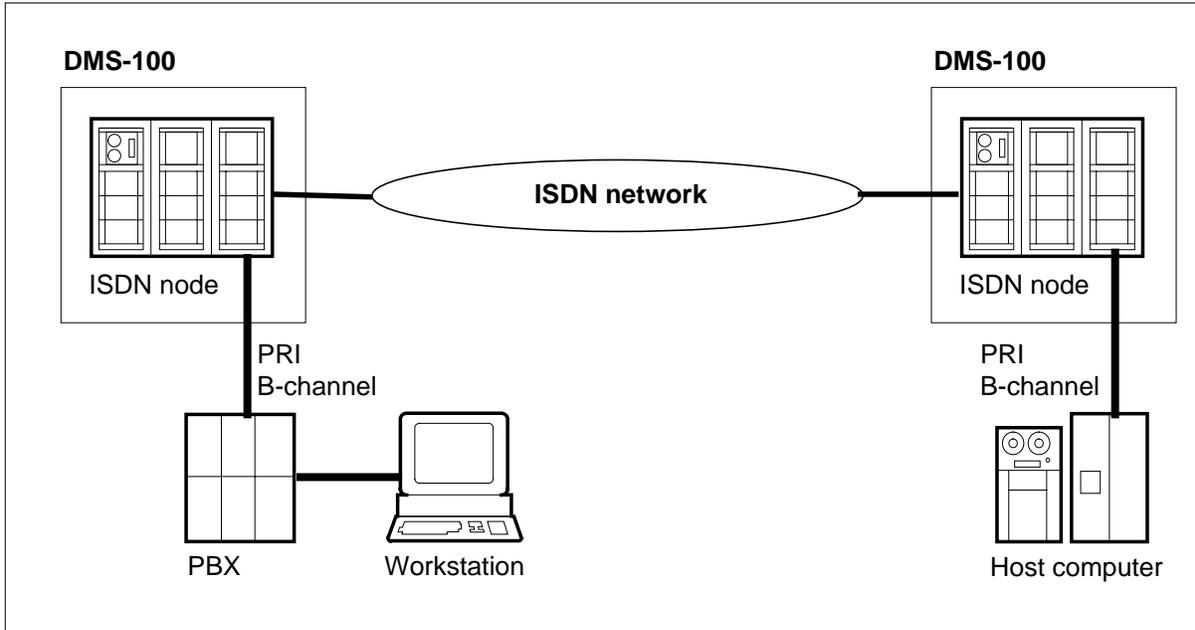

B-channels can have different bearer capabilities. Bearer capability is defined by the field values in the bearer capability information element of the Q.931 call setup message. Table 2-1 shows a short description of these fields. The network confirms that the bearer capability information element received from the user matches the bearer service provided to that user by the network. If a mismatch occurs, the network rejects the call.

The following call types are possible for bearer capability:

- speech
- unrestricted data, 64-kbit/s rate adapted from 56 kbit/s
- unrestricted data, 64 kbit/s clear

- restricted data, 64 kbit/s
- 3.1-kHz audio

**Table 2-1 Bearer capability information element**

Field	Possible values
Information transfer capability	speech, or unrestricted digital information, or restricted digital information, or 3.1 kHz audio (see note)
Transfer mode	circuit mode
Information transfer rate	64 kbit/s
Structure	8 kHz integrity
Configuration	point-to-point
Establishment	demand
Symmetry	bidirectional
User information re: Layer 1 protocol	rate adapted, or m-law speech
User rate	55 kbit/s
<b>Note:</b> Speech and 3.1 kHz audio receive identical treatment.	

**D-channels**

D-channels provide all signaling and call control for the B-channels that use CCITT standard protocols. One D-channel can support signaling for multiple DS-1 links, and is referred to as consolidated signaling (see Figure 2-4).

**Figure 2-4 PRI consolidated signaling**

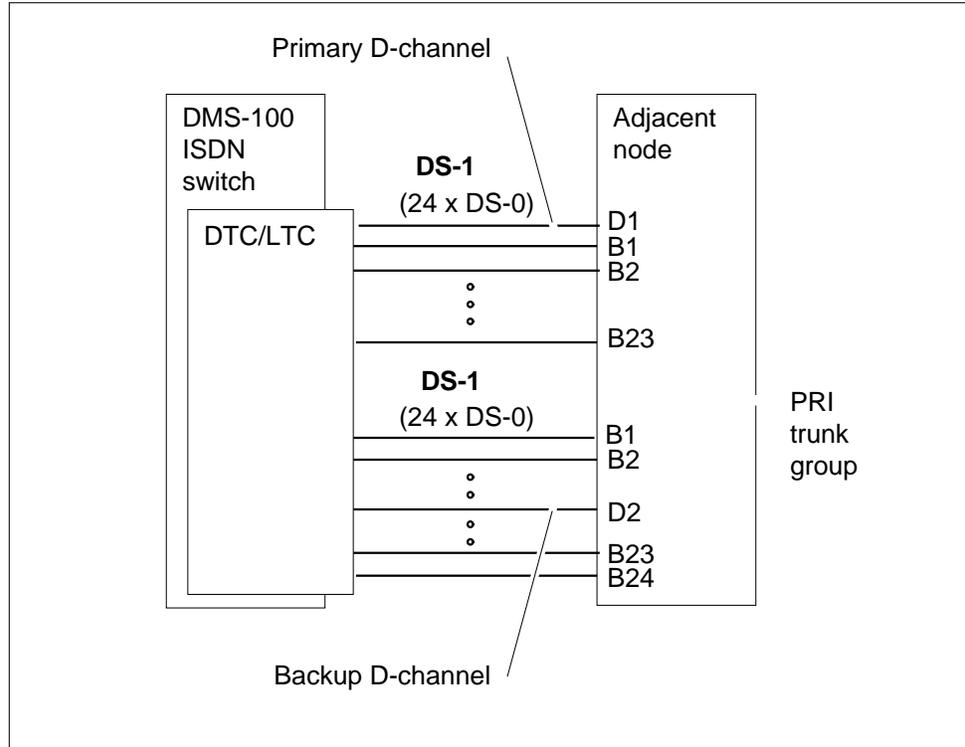

**D-channel protocol**

Under supervision of the DMS-core, the PRI XPM software performs connection management, including:

- internal channel allocation and deallocation
- call connection timing
- connection integrity supervision

*Note:* For simplicity, all references to the EISP mean the EISP or ISP, and all references to the UP mean the UP or the SP and the MP.

D-channel operation requires the creation of logical data links. These links are set up between service access points within the ISDN using service access point identifiers (SAPI). The D-channel handles SAPI 0 (call control) messages. The destination of SAPI 0 messages from the adjacent node is the EISP.

The EISP checks the frame sequencing and the digits that are built into the Q.931 frame. The EISP then requests a retransmission of the lost or invalid frames. The EISP assembles the Q.931 messages destined for the adjacent node and responds to requests for retransmission.



The UP converts Q.931 SAPI 0 messages into the DMS-core format and sends them to the DMS-core. The UP also performs the reverse function, reformatting DMS-core messages into Q.931 format for the adjacent node. The UP software also tracks call states and sends call state information to the adjacent node.

Figure 2-5 shows how the lower layers are removed from the Q.931 message as it passes through the processing steps, leaving only the call information going to the DMS-core.

**Figure 2-5 PRI D channel processing**

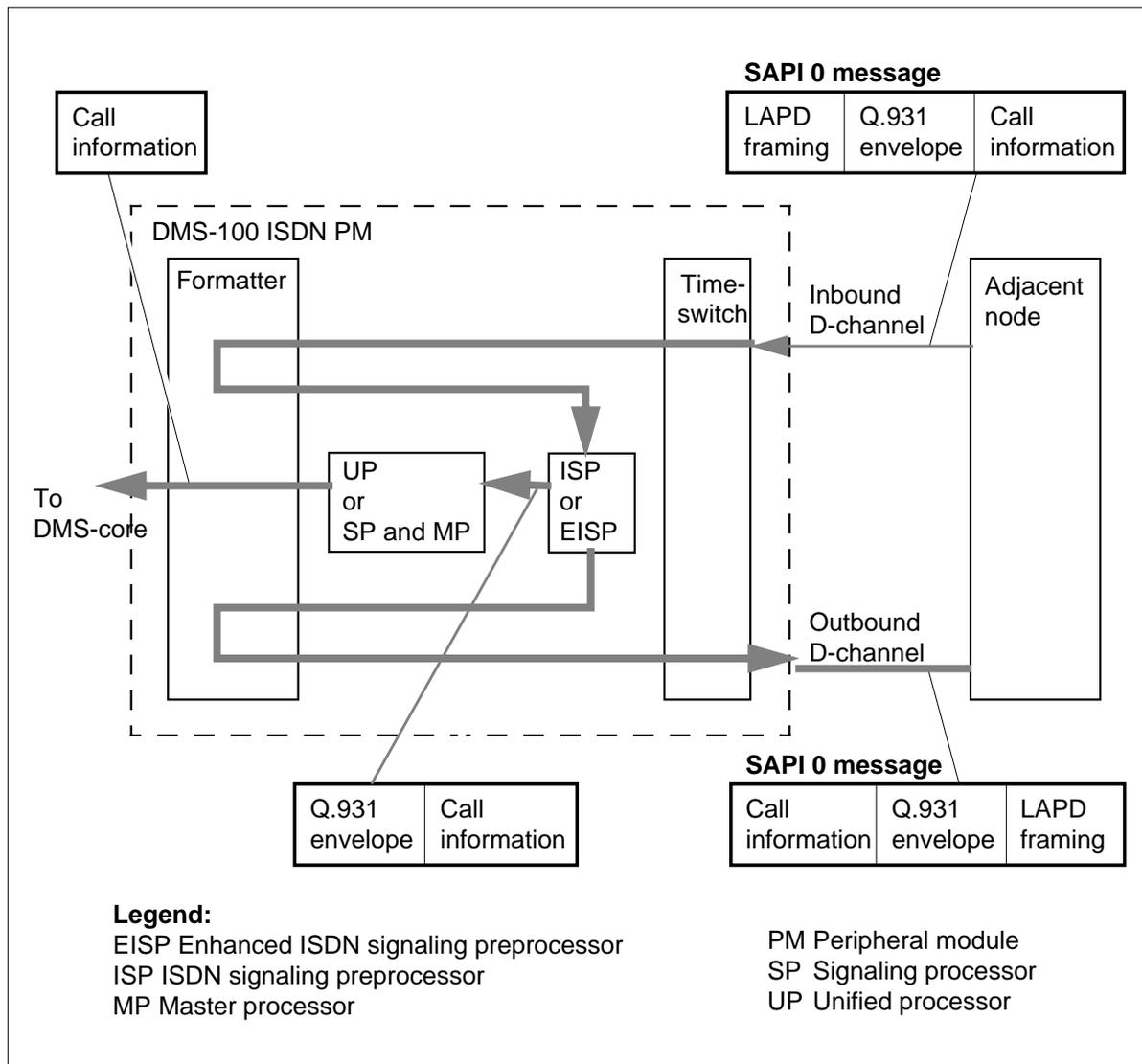

## Automatic maintenance

DMS-100 switch automatic maintenance joins fault detection and fault correction. A group of hardware and software functions make fault detection possible.

When the system detects a fault, the DMS-100 switch uses three plans to automatically correct the fault:

- isolate and replace the faulty unit (for example, SWACT)
- reload corrupted software
- find a new data path

## ISDN XPM automatic maintenance

The DMS-100 switch has many self-checking features, including switch of activity (SWACT) and routine exercise (REx) test.

### Switch of activity

In the SWACT process, two mate units switch activity. The active unit becomes the inactive unit, and the inactive unit becomes the active unit and takes over call processing. The SWACT can be

- cold (all calls are dropped)
- warm (established calls are maintained but unestablished calls are dropped)
- controlled (requested by system or operating company personnel)
- uncontrolled (the unit stops responding)

### Routine exercise (REx) test

A REx test is a series of tests performed on an XPM unit. A REx test joins the diagnostic and functional routines available on XPMs. Perform a REx test each day, or initiate a test automatically by the system scheduler or manually by operating company personnel. Four types of results of the REx test can occur:

- not performed
- pass
- fail
- cancel by manual action (operating company personnel cancel the REx test using the FORCE option or ABTK command)

All four classes output a log or display a message at the MAP terminal. The maintenance record stores all passed and failed REx test results. Log PM600 provides information about failure reasons when the REx test fails. For more information about REx tests, refer to chapter “Preventive maintenance strategies”.

### **Escalation to manual maintenance**

If automatic maintenance does not correct a fault in the DMS-100 switch, the DMS-100 switch provides trouble indicators. These trouble indicators indicate that a fault condition still exists. Alarms are examples of trouble indicators. Some OMs and logs indicate a fault condition and failure of automatic maintenance. Manual intervention becomes necessary as maintenance personnel at the MAP terminal try to find and clear the fault.

### **Card requirements**

This section describes ISDN PRI shelf layouts and ISDN PRI-related cards. For information about ISDN frames and cabinets, refer to the *Translations Guide* or the *Hardware Description Manual Reference Manual*.

### **Shelf layouts**

This section describes the shelf layouts for PRI-related hardware. This section includes descriptions of the ISDN digital trunk controller (DTCI) and the ISDN line trunk controller (LTC).

#### **DTCI shelf layout**

A DTCI has two shelves, unit 0 and unit 1. Figure 2-6 shows the shelf layout for a DTCI configured as an XPM.

The XPM configuration has the following processor cards:

- enhanced ISDN signaling processor (EISP) card
- unified processor (UP) card

Each shelf has the following cards to complete the DTCI control complex:

- time switch card
- message protocol and tone generator (MPC) card
- formatter (FORM) card
- channel supervision message (CSM) card

Each shelf has the following cards that provide central-side (C-side) and peripheral-side (P-side) interfaces:

- DS30 interface card (C-side)
- DS-512 interface card (C-side)
- DS-1 interface cards (P-side)

Figure 2-6 DTCI shelf layout for an XPM configuration

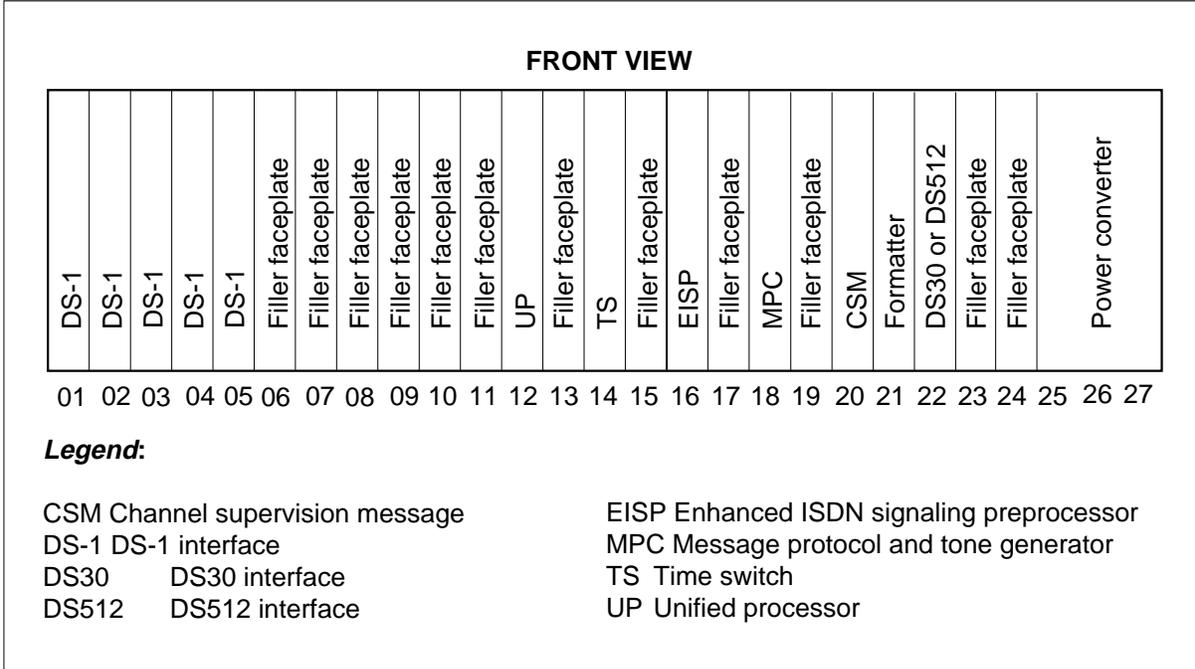

**ISDN line trunk controller**

Figure 2-7 shows the arrangement of cards in an ISDN line trunk controller (LTC). The cards in each shelf of the LTC are identical to the cards on a DTCI shelf with one exception. The cards in slots 1 to 5 of the LTC can contain a D-channel handler (DCH) card or a DS-1 interface card, and slot 17 contains a universal tone receiver (UTR) card. For more information about the DCH and UTR cards, refer to *Translations Guide*.

When in use for both ISDN PRI and basic rate interface (BRI), the ratio of DCH cards to DS-1 cards is flexible and depends on the requirements for each type of service in each office.

Figure 2-7 LTC equipped for ISDN shelf layout

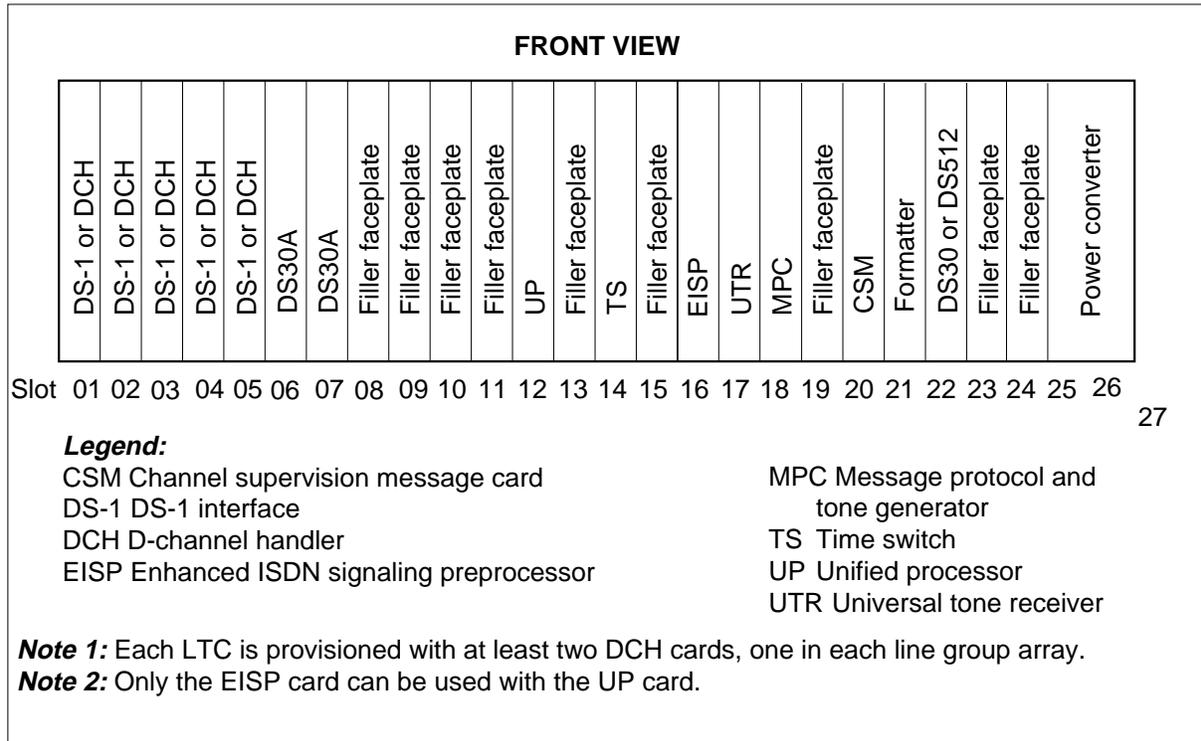

**Cards**

Table 2-2 lists the following information for each ISDN PRI-related card:

- product engineering code (PEC) code
- PEC suffix
- card name

2-12 ISDN PRI hardware components

- slot number
- functions and comments

*Note:* This section describes only the PRI-specific cards. For more information about the DCH and UTR cards, refer to *Translations Guide*.

Table 2-2 ISDN PRI cards (Sheet 1 of 4)

PEC	PEC suffix	Card name	Slot	Comments and functions
NT0X50		Filler card	any slot not occupied	<p><i>Functions</i></p> <p>Fills any slot not occupied by a functional card.</p>
NT2X70	AE	Power converter card	25 to 27	<p><i>Functions</i></p> <p>Converts -48V input to a +5V, -5V, and +12V output.</p>
NT6X40	AC BA	DS30 C side interface card	22 and 23	<p><i>Functions</i></p> <ul style="list-style-type: none"> <li>• Converts the internal DTCl signal to the bipolar encoded signal used on a DS30 link.</li> <li>• Carries B- and D-channels between the DTCl and the network.</li> </ul>
NT6X40	CA DA	DS512 C side interface card	22 and 23	<p><i>Functions</i></p> <ul style="list-style-type: none"> <li>• Converts the internal DTCl signal to the 512 channel, pulse code modulated (PCM) signal that can connect to a fiber link and to the enhanced network (ENET).</li> <li>• Carries B- and D-channels between the DTCl and the network.</li> </ul>
NT6X41	AA	Speech bus formatter card	21	<p><i>Functions</i></p> <p>Converts the parallel bit stream in use on the internal speech bus to a DS30 bit stream, and the DS30 bit stream to a parallel bit stream.</p>
NT6X42	AA	Channel supervision message (CSM) card	20	<p><i>Functions</i></p> <ul style="list-style-type: none"> <li>• Manages the speech link between the DTCl and the network.</li> <li>• Reports error conditions to the SP or the UP card.</li> </ul>

Table 2-2 ISDN PRI cards (Sheet 2 of 4)

PEC	PEC suffix	Card name	Slot	Comments and functions
NT6X44	AA AB	Time switch card	14	<p><i>Functions</i></p> <ul style="list-style-type: none"> <li>Converts a serial data stream it receives from (or transmits to) the DS30A interface card to a parallel data stream in use on the internal speech bus.</li> <li>Associates a DS30A or a DS-1 channel with a time slot on the parallel speech bus, and transfers data between the DS30A or DS-1 channel and the time slot.</li> </ul>
NT6X45	AB, AC,BA	LTC/DTC/LG C processor CP card	08 or 12	<p><i>Functions</i></p> <ul style="list-style-type: none"> <li>The NT6X45BA is functionally equivalent to the NT6X45AB and NT6X45AC versions, but is application-specific.</li> <li>Runs the programs that control the formatter card, the channel supervision message card, and the timeswitch card.</li> </ul>
NT6X46	BA,BB	Signaling processor memory card	11	<p><i>Comments</i></p> <ul style="list-style-type: none"> <li>The SP can be equipped with only one NT6X46BA card.</li> <li>The NT6X46BA is functionally equivalent to the NT6X45BB.</li> </ul> <p><i>Functions</i></p> <p>Provides the RAM for the SP card and also contains the direct memory access (DMA) memory.</p>
NT6X47	AC	Master processor memory circuit card	09 to 10	<p><i>Functions</i></p> <p>Provides random access memory (RAM) for the MP card and contains the DMA memory.</p>

Table 2-2 ISDN PRI cards (Sheet 3 of 4)

PEC	PEC suffix	Card name	Slot	Comments and functions
NT6X50	AB	DS-1 interface card	01 to 05	<i>Functions</i> Converts between the unipolar signal type in use for internal DTCI communication and the bipolar encoded signal used on a DS-1 link.
NT6X69	AB AC	CPP message protocol and tone circuit pack	18	<i>Comments</i> NT6X69AC is compatible with fibre-optics applications. <i>Functions</i> Supervises the receipt of all incoming control messages and the transmission of all outgoing messages between the DTCI and the DMS-core.



Table 2-2 ISDN PRI cards (Sheet 4 of 4)

PEC	PEC suffix	Card name	Slot	Comments and functions
NTBX01	AA AB	ISDN signaling preprocessor card	16	<p><i>Comments</i></p> <ul style="list-style-type: none"> <li>• NTBX01AB is the enhanced ISP (EISP) card.</li> <li>• The EISP card provides the following enhancements: <ul style="list-style-type: none"> <li>— 3 Mbyte more memory (when used with a UP card)</li> <li>— faster clock speed by 4 MHz</li> <li>— data bus with twice the width (32 bits)</li> </ul> </li> </ul> <p><i>Functions</i></p> <ul style="list-style-type: none"> <li>• Provides call control messaging functions and D-channel maintenance functions</li> <li>• Provides an interface between the D-channel cards and the other processors in the DTCl (MP, SP, and UP).</li> <li>• Receives Q.931 messages from the D-channel and recodes them into a format suitable for the switching network.</li> <li>• Sends the recorded messages to the MP or the UP, which are sent to the switching network through the DS30 card.</li> </ul>
NTMX77	AA	Unified processor (UP) card	12	<p><i>Comments</i></p> <p>Replaces NT6X45, NT6X46, and NT6X47 cards.</p> <p><i>Functions</i></p> <ul style="list-style-type: none"> <li>• Replaces the MP and SP processor cards and their associated memory cards.</li> <li>• The UP card offers increased real-time capacity, increased addressable memory, and decreased power consumption by shelf.</li> </ul>

### Card replacement procedures

Card replacement procedures for the cards described in this chapter are documented in *Card Replacement Procedures*.

### Fault conditions

This section lists the types of faults that can affect PRI. These faults can suggest a course of analysis when troubleshooting a PRI problem. Every component in the DMS-100 can cause one or more faults. Nortel can not provide an exhaustive listing. This section lists general fault conditions associated with ISDN PRI, and a few detailed examples.

The following is a list of the general errors that can occur with PRI:

- hardware faults
- software errors
- datafill errors
- cabling problems
- provisioning issues

**Table 2-3 Other hardware fault conditions**

Fault condition	Description
Activity timeout	The C-side message links are broken, so messaging cannot occur.
Duplicate fault	A critical hardware fault has occurred.
Jammed	The unit is jammed, meaning that it cannot change its active/inactive status.
Static data corruption	There is a checksum error in the static data.
Hardware trap	Parity causes a processor trap, bus error, or memory management.

### Fault condition results

Faults can generate alarms, logs, or OMs. Subscriber complaints can indicate fault conditions. Refer to the “Trouble isolation and correction methods” chapter for information about the test tools for use to analyze and clear fault conditions. Refer to the chapter “User interface” for information about MAP levels, MAP commands, and XPM, trunk, carrier, and D-channel status indicators.

## 3 ISDN PRI software components

This chapter provides a brief description of the ISDN PRI software protocols used in a DMS-100 integrated services digital network (ISDN) node and the ISDN PRI features that are available through release NA013.

### OSI model and ISDN PRI protocols

ISDN PRI protocol follows the open systems interconnection (OSI) model developed by the International Standards Organization (ISO). The OSI model has seven layers, as shown in Figure 3-1. ISDN is implemented through layers 1 to 3 of the OSI model. Figure 3-1 also shows the CCITT standards that correspond to the first three layers.

**Figure 3-1 OSI and ISDN model comparison**

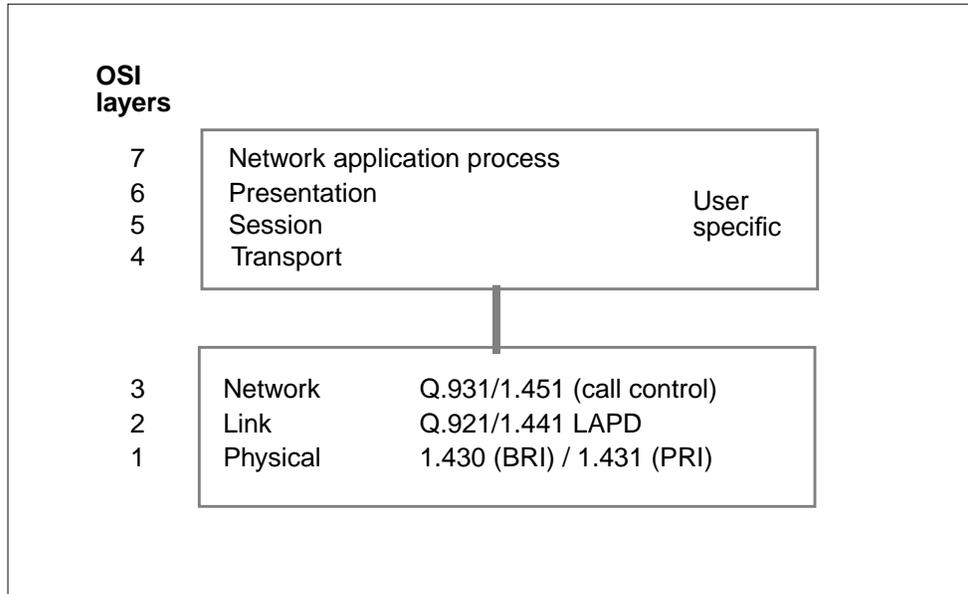

#### Layer 1 (physical) protocol

The physical layer provides the physical characteristics. These characteristics include the wire connections, transmission of electrical signals between

endpoints, the frame structure of the bit stream, channel allocation, and activation and deactivation of links.

The physical hardware for PRI includes digital trunks and the ISDN digital trunk controller (DTCI). PRI trunks use the DS-1 signaling format. The DMS-100 ISDN node supports the two frame formats, superframe (SF) and extended superframe (ESF). Figure 3-2 shows the SF format and the DS-1 format.

#### **Superframe and extended superframe**

SF joins 12 standard DS-1 frames together. A multiframe framing pattern is in use to identify the frame and superframe limits. This framing pattern is the binary code 100011011100. See Figure 3-2 for an illustration of this framing pattern.

ESF joins 24 standard DS1 frames together. For more information about the SF and ESF formats, refer to the *ISDN Primary Rate Access User-Network Interface Specification*, NIS A211-1.

Two encoding formats are in use for PRI:

- ZCS (Zero code suppression)
- B8ZS (Bipolar with 8-zero substitution)

ZCS prevents the transmission of more than eight consecutive zeros by changing the eighth bit to a 1. This process is known as bit robbing. B8ZS uses a line coding technique that does not affect the data bit stream.

Figure 3-2 DS-1 and Superframe signaling formats

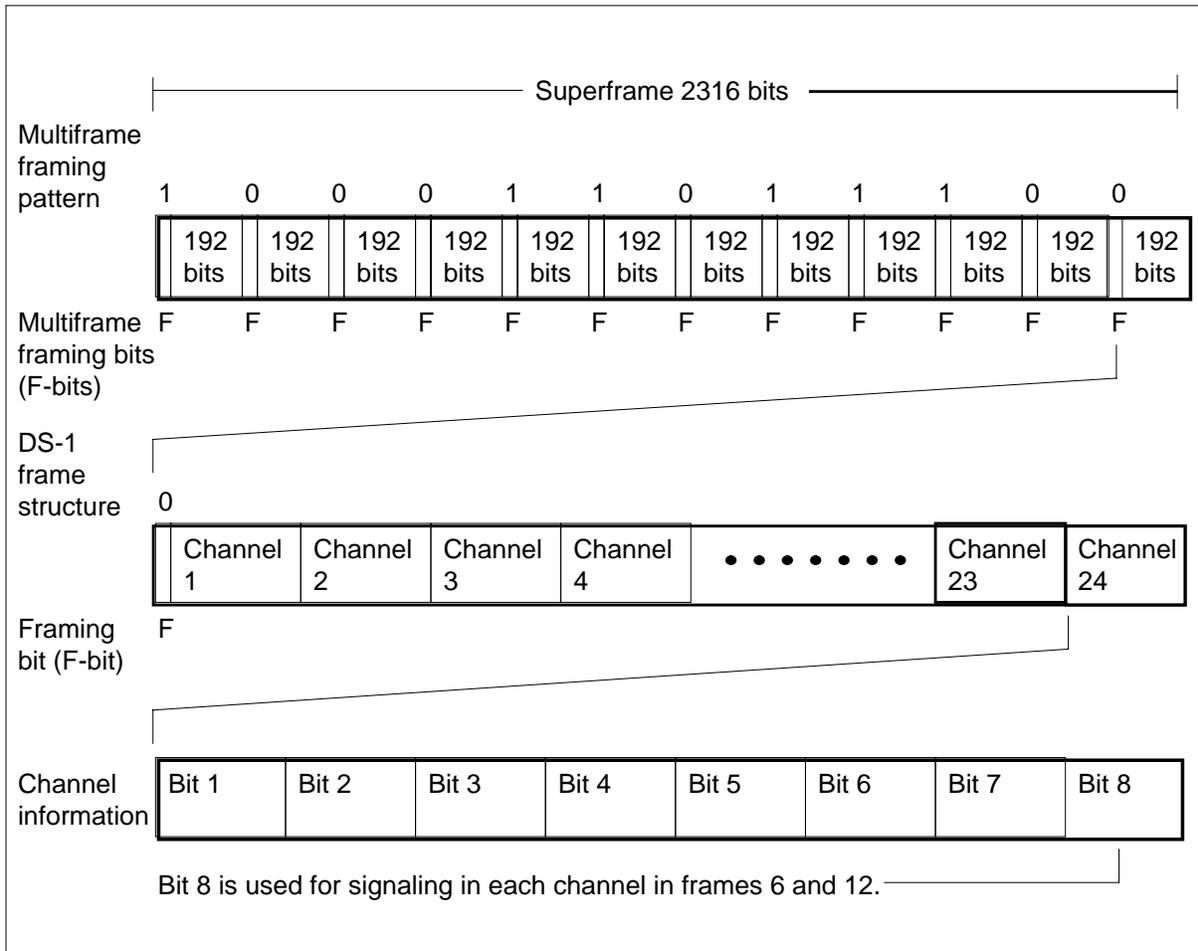

## Layer 2 (data link) protocol

The data link layer provides the logical links between the CPE and the DMS-100 switch. There are two types of messaging formats: one for the B-channels; the other for the D-channel.

### D-channel

For the D-channel, the layer 2 protocol is link access procedure on the D-channel (LAPD), a protocol defined by CCITT recommendation Q.921. LAPD, a derivative of the International Standards Organization (ISO) high-level data link control (HDLC) standard, uses an HDLC frame format that has two octets of data link layer address information consisting of

- a service access point identifier (SAPI) to identify a layer 3 entity
- a terminal endpoint identifier (TEI) to address individual terminal devices on an ISDN loop

### **Layer 3 (call control or network) protocol**

Layer 3 is the call control layer of ISDN operating over the D-channel that defines the procedures for

- establishing, maintaining, and clearing one or more connections of the same type on a logical data link created by layer 2
- controlling access to supplementary services, among them MDC features, through functional feature management

### **Q.931 protocol**

The call control software communicates with functional signaling terminals on the D-channel using call control messages. The structure of a call control message is defined in the CCITT recommendation Q.931.

The protocol procedure is based on

- setup and take down of calls and features between the network and PBX
- address displays and progress indicators at the PBX and network
- B-channel control from the network

The Q.931 protocol supports basic error-handling procedures and re-initialization after the occurrence of recoverable errors. The Q.931 protocol (level 3) also determines the signaling methods used in circuit-switched calls.

## **ISDN PRI features**

The following briefly describes the features that are unique to ISDN PRI or serve ISDN BRI and ISDN PRI.

### **Features added in NA014**

The following ISDN PRI feature was added for release NA014: 59017193 PRI Originating Calling Name Delivery. This feature replaces the associated software patches that were put in place in the NA012 release time frame.

#### **Feature name**

PRI Originating Calling Name Delivery

#### **Description**

PRI Originating Calling Name Delivery is an originating feature that provides the called party (terminating agent) with the calling party's name when the call originates over a primary rate interface (PRI) trunk. Prior to this activity, integrated services digital network (ISDN) user part (ISUP) was the only originating trunk type that supported calling name deliver (CNAM). In NA009, feature activity AF7209 provided CNAM for terminating PRI trunks. This feature extends the CNAM functionality developed in activity AF7209 to originating (outgoing) PRI trunks.

The calling name is retrieved in one of two ways:

- a centralized data base using transaction capabilities application part (TCAP) messaging
- a local table lookup

This enhancement affects the public network and is only supported by the NI-1 (NTNA), NI-2, 4ESS, and 5ESS PRI variants.

For intra-switch calls, the calling directory number (DN) is obtained from the calling party's DN on the switch. For inter-switch calls, the DN is obtained from the calling party number parameter of the ISUP initial address message (IAM). Transporting calling name information for inter-switch calls is dependent on Common Channel Signaling System No. 7 (CCS7) connectivity between the originating and terminating offices. The TCAP query with permission package provides a North American Numbering Plan (NANP) DN for use by the database to lookup the calling name information.

The centralized residence name database provides a name with a maximum of 15 characters in length and a permanent privacy indicator. The information retrieved by the database is passed to the terminating switch in a TCAP response package. The TCAP response is packaged and sent to the intelligent peripheral (IP) if all presentation conditions are met.

### **Overview of PRI Originating Calling Name Delivery**

The PRI Originating Calling Name Delivery feature is made up of the following three major components:

- Provisioning—includes existing parameters and options developed in activity AF7209 that enable PRI Calling Name Delivery.
- TCAP handling—provides the launching of the TCAP name query to a centralized name database and the decoding of the TCAP name response from the database.
- Message delivery—uses the Q.931 messaging developed in activity AF7209 to include the calling name in a FACility IE in a terminating Q.931 SETUP message or FACility message.

### **PRI Originating Calling Name Delivery option TCAP\_CNAM**

The PRI Originating Calling Name Delivery option developed in activity AF7209 is required to enable this feature. Since line options cannot be assigned to trunks, the option must be associated with the logical terminal. The boolean TCAP\_CNAM service option in the LTDATA table is associated with the trunk's logical terminal identifier (LTID). The service option is checked by a PRI terminating agent to determine whether to deliver the calling user's name. If the TCAP\_CNAM option does not appear on the PRI interface, the

calling name is not delivered. The key to the LTDATA table is the LTID and the data selector.

The following is an example of the LTDATA table with option TCAP\_CNAM.

**Table 3-1 Example of datafill for option TCAP\_CNAM in table LTDATA**

LTDKEY	LTDRLT	OPTIONS
ISDN 10 SERV	SERV Y Y ALWAYS ALWAYS	(TCAP_CNAM)

**Office parameter IAM\_USE\_NAME\_CHARS**

This feature needs an existing office parameter to deliver PRI originating CNAM. The IAM information element of ISUP contains the generic name (GN) parameter. The GN contains the calling name and the presentation indicator (PI) The office parameter in the OFCENG table controls the use of the calling name in the IAM.

For example, if the office parameter IAM\_USE\_NAME\_CHARS in the OFCENG table is set to yes, the calling name is obtained from the GN of the ISUP IAM. A TCAP query is not generated and the calling name in the GN is delivered to the customer premises equipment (CPE). If the office parameter is set to no, the calling name in the IAM is ignored. the default data for this parameter is yes.

The following shows an example of datafill in the OFCENG table.

**Table 3-2 Sample datafill in the OFCENG table**

PARAMNAME	PARMVAL
IAM_USE_NAME_CHARS	Y

**TCAP name local lookup provisioning**

Sub-option TCAPNM was developed in NA009.009. Datafill in the CUSTNM table controls this sub-option. This sub-option provides two choices, LOCAL and NONLOCAL. When set to LOCAL, the TCAPNM local lookup feature is in effect and searches the local DMS database for the calling name, or captures the calling name from the party information parameter (PIP) of the ISUP IAM. The NONLOCAL setting turns off the local lookup feature and uses CNAM.

The default value of the TCAPNM option is NONLOCAL. The LOCAL value of the TCAPNM sub-option must be set to activate the local lookup functionality.

*Note:* If the customer group provisioned with option TCAPNM is not assigned to the respective PRI LTID in the LTCALLS table, the TCAPNM



functionality will not be executed. The customer group must be assigned to the corresponding LTID to offer the TCAP Name Local Lookup feature.

### inter-LATA name query control

The existing office parameter TCAPNM\_inter-LATA\_QUERY in the OFCVAR table enables the operating company to decide if inter-LATA calls require a TCAP query. This parameter has two possible values, Y (yes) and N (no). If set to Y, both intra-LATA and inter-LATA calls perform TCAP queries when necessary. When the parameter is set to N, only intra-LATA calls perform TCAP queries. The default data for this parameter is N. The following is an example of sample datafill in the OFCVAR table.

**Table 3-3 Sample datafill in the OFCVAR table**

PARAMNAME	PARMVAL
TCAPNM_inter-LATA_QUERY	N

### TCAP interface

This feature uses the TCAP layer of the SS7 protocol to retrieve the name information from the centralized name database, the same centralized name database used in the residential CNAMD feature. Therefore, this feature requires all necessary datafill for the CNAMD TCAP subsystem and messaging interface between the end office and the name database.

Refer to AN0232: CLASS: TCAP for Calling Name Delivery for the CNAMD subsystem and TCAP messaging provisioning requirements.

### TCAP handling

Upon termination, the following conditions must be examined to determine whether to launch a TCAP calling name query.

- PRI calling name delivery option is datafilled in the LTDATA table
  - The TCAP\_CNAM service option in the LTDATA table for PRI calling name delivery must be datafilled for this functionality to be enabled. The terminating agent checks the TCAP\_CNAM service option to determine whether to launch a TCAP query and deliver the calling user's name. If the TCAP\_CNAM option does not appear on the PRI interface, a TCAP query is not initiated and the calling name is not delivered.
- TCAP name local lookup status
  - The existing TCAPNM option developed under activity AF7157 is used to determine whether of not to launch a TCAP query. The modified TCAPNM feature gives the operating companies the

flexibility of datafilling names locally on the DMS switch to avoid performing TCAP name queries.

When the local name lookup feature is active, it intercepts any attempt to launch a TCAP name query and then searches for a local name for that particular calling DN. If a local name is not found, the switch sends a TCAP name query to obtain the calling name.

- inter-LATA name query control
  - If the call is inter-LATA, the switch checks to see if inter-LATA TCAP queries are permitted. The existing office parameter, TCAPNM\_inter-LATA\_QUERY in the OFCVAR table, has two possible values, Y (yes) and N (no). When set to Y, both intra-LATA and inter-LATA calls perform TCAP queries when necessary. When the parameter is set to N, only intra-LATA calls perform TCAP queries. The default data for this parameter is N.
  - To determine if a call is inter-LATA, the calling party number must be available in the IA, and the Nature of Address in the calling party number parameter must indicate a unique or non-unique national number. When these conditions are met, the switch uses the LATA of the called line (obtained from the LINEATTR table) and the calling number to index into table LATA\_XLA. The tuple obtained from the table specifies if the call is an inter-LATA or intra-LATA call.

*Note:* The call is classified as inter-LATA by referring to the LATA field in the LATA\_XLA table.

- If the parameter TCAPNM\_inter-LATA\_QUERY is set to N and the call is determined to be inter-LATA, no TCAP query is performed, and an out-of-area indicator is sent to the called party's CPE.
  - In the event the LATA\_XLA table is not present in the switch, the parameter TCAPNM\_inter-LATA\_QUERY is not referenced, and a TCAP query is performed if necessary (based on the other criteria). If the table is present, but the desired tuple does not exist in the table, the call is classified as intra-LATA, and a TCAP query is performed if necessary.
- The user provided or network provided calling number must be present.
    - A user-provided North American Numbering Plan (NANP) calling number or network provided NANP calling number must be present to launch a TCAP query.
  - The calling number privacy indicator
    - The switch checks the calling number privacy indicator (PI) to determine the calling name presentation status. The calling number PI has three possible variables, private, allowed, or blocking toggle. The

calling name PI is not examined when determining the presentation status of the calling name.

- If the calling number PI is private, the switch does not launch a TCAP query and does not present the calling name. The switch sends a presentation restricted indication to the CPE.
- If the calling number Pi status is allowed, the switch launches a TCAP query and presents the calling name to the CPE provided that the other required conditions are met.
- I-CNAM does not support the blocking toggle parameter of the calling number PI and interprets it as a private indication. Thus, a TCAP query is not launched and the calling name is not presented. The switch sends a presentation restricted indication to the CPE.

### **Launching a TCAP query**

Once it has been determined that a TCAP name query should be sent, the switch launches a TCAP query to the centralized database using the calling party's DN as an index. The TCAP interface only supports the NANP.

If a TCAP query is unsuccessful because of overload or lack of software resources to send a TCAP query (such as, no available transaction ID's), a not available indication is delivered to the called party through a FACility IE.

When the switch launches a successful TCAP query, the switch also sends the initial Q.931 SETUP message to the called party.

If the calling name is unavailable or restricted, the switch sends no TCAP query. The called party receives a private or not available name indication in the Q.931 SETUP message.

### **Processing a TCAP query response**

The response from the central name database is received in a TCAP query response message.

### **The TCAP name is available**

If the name is available in the TCAP database, the switch delivers a FAC message with the name to the called party. If the name is not available in the database, the FAC message will have a name not available indication.

### **Handling a TCAP query response after the call is released**

If the switch receives the TCAP query response message after the call has been released, but before the TCAP timer has expired, the name is not delivered. No log reports are generated.

The following table is a summary of the I-CNAM actions based on the ISUP calling number (CGN) PI.

**Table 3-4 I-CNAM action based on ISUP CGN PI**

<b>Calling number presentation indicator</b>	<b>TCAP database</b>	<b>Delivery to called TCAPNM subscriber</b>
Allowed	Name available	Name
Allowed	Name not available	Unavailable indication
Restricted	No query generated	Unavailable indication
No indication (or no OSUP CPN in IAM)	Name available	Unavailable indication

**Hardware requirements**

PRI Originating Calling Name Delivery has no hardware requirements.

**Limitations and restrictions**

The limitations and restrictions that follow apply to the PRI Originating Calling Name Delivery feature.

**SUPPRESS line and DNGRPS option**

The limitations and restrictions that follow apply to the SUPPRESS line and DNGRPS option:

- The SUPPRESS DNGRPS network option for the calling party affects the delivery of the TCAP calling name. If the option is set to SUPPRESS NAME in DNGRPS, it does not affect TCAP name delivery. If the option is set to SUPPRESS NUMBER in DNGRPS, it prevents I-CNAM delivery.
- The LTCALLS table can be used to suppress CGN. The LTDATA table can be used to suppress CGN and CDN for originating calls.

**Transaction capabilities application part**

The limitations and restrictions that follow apply to the transaction capabilities application part.

The I-CNAM feature uses the TCAP layer of the SS7 protocol to retrieve the name information from the centralized name database. This feature uses the TCAP interface defined by the RES CNAMD TCAP feature. Refer to AN0232 for more information on the TCAP packages: Automatic Call Gapping (ACG)

procedures, Transaction ID (TRID) management, Signaling Connection Control Part (SCCP) translations and routing and TCAP timing.

- This feature only applies to NI-1 9 (NTNA), NI-2, 4ESS, and 5ESS PRI variants.
- When a TCAP query is launched, an Out of Area indication is not included in the SETUP message.
- The Federal Communications Commission (FCC) has ruled that the calling number presentation indication and the calling name presentation indication must be linked. Therefore, PRI I-CNAM does not reference office parameter TCAPNM\_BLK\_QUERY\_PRIV\_DNS and uses the calling number presentation indication only.

For example, an end user may not have a private number with a name that is deliverable. To adhere to the FCC ruling, the office parameter TCAPNM\_BLK\_QUERY\_PRIV\_DNS in the OFCVAR table, which links the name and number privacy, is no longer checked. The privacy status is always determined from the calling number privacy indicator. This office parameter was provided prior to NA008.

- I-CNAM does not support the blocking toggle parameter of the calling number PI and interprets it as a private indication. Thus, a TCAP query is not launched and the calling name is not presented. The switch sends a presentation restricted indication to the CPE.
- All necessary datafill for providing the residential and MDC TCAP CNAMD (and BRI I-CNAM) functionality are required.
- This activity does not support Redirecting Name Delivery (RNAM).

### **Call Forward Universal, Call Forward Busy, Call Forward Fixed, Call Forwarding Don't Answer**

If the called party has any kind of call forwarding feature, the DMS 100 switch has no indication of this and delivers the retrieved TCAP name over the PRI trunk. It is the responsibility of the terminating CPE to handle the I-CNAM delivery.

### **Call Hold, ISDN Hold**

If the switch delivers the TCAP name to the called party and the called party subsequently uses Call Hold or ISDN Hold, it is the responsibility of the CPE to handle the I-CNAM delivery.

### **Calling Number Delivery**

If the calling party is subscribed to CND, both calling name and the calling number are displayed.

### **Calling Identity Delivery and Suppression**

Using features CNND and CNNB an originator can deliver or block both name and number. If the originating party has activated CNNB, the switch does not deliver the calling name.

### **Other features**

The following features have no affect on I-CNAM delivery.

- Calling Name Delivery (CNAMD)
- Last Number Redial (LNR)
- Ring Again (RAG)
- Network Ring Again (NRAG)
- Speed Call

### **Datafill**

PRI Originating Calling Name Delivery does not change data schema tables or office parameters.

### **Service orders**

PRI Originating Calling Name Delivery does not change the Service Order System (SERVORD).

### **Operational measurements**

PRI Originating Calling Name Delivery does not change operational measurements (OM).

### **Logs**

PRI Originating Calling Name Delivery does not change logs.

### **User interface**

PRI Originating Calling Name Delivery does not change the user interface.

### **Billing**

PRI Originating Calling Name Delivery does not generate billing records or changes.

### Other ISDN PRI features

Table 3-5 shows the ISDN PRI features that are available for the DMS-100 switch and the applicability to NI-1 and NI-2.

**Table 3-5 ISDN PRI feature availability (Sheet 1 of 2)**

Feature	NI-1	NI-2	Comments
B-channel Service Messaging	Yes	Yes	Not mandatory for NI-2, but strongly recommended
Call-by-Call Service	No	Yes	For NI-1, this is called Integrated Services Access (ISA).
Call Forward/Interface Busy	Yes	Yes	
Calling Line Identification	Yes	Yes	
Dialable Wideband Service	Yes	Yes	
E911 Preferred DN	No	Yes	
ISP Even Call Distribution	Yes	Yes	Used for internet service providers (ISP).
MSR Name Display and Universal DN System Support	No	Yes	
NCAS Framework	No	Yes	
Networked ACD on PRA	Yes	No	
PRI Backup D-channel	Yes	Yes	
PRI Base Service	Yes	Yes	
PRI Bearer Capability Routing	Yes	Yes	
PRI Call Routing	Yes	Yes	
PRI Call Screening	Yes	Yes	
PRI Calling Line Identification Blocking	Yes	Yes	
PRI Calling Name Delivery	Yes	Yes	NI-1 uses switched-based name. NI-2 uses a TR-1188 based name or a switched -based name.
PRI: Disruptions and Abnormalities	No	Yes	
PRI Equal Access	Yes	Yes	

**Table 3-5 ISDN PRI feature availability (Sheet 2 of 2)**

<b>Feature</b>	<b>NI-1</b>	<b>NI-2</b>	<b>Comments</b>
PRI Flexible Timers	Yes	Yes	
PRI Hotel/Motel and Selective Class of Call Screening for NIPRI	No	Yes	
PRI ISDN Treatments	Yes	Yes	
PRI: Location Indicators	Yes	Yes	
PRI Message Waiting Indicator	Yes	Yes	
PRI network Name Delivery	Yes	No	
PRI Network Ring Again	Yes	No	
PRI: OFM–Data Link Monitor	No	Yes	
PRI Originating Calling Name Delivery	Yes	Yes	
PRI: PRI Over Multiple XPMs	No	Yes	
PRI SUSP for CNAME	No	Yes	
PRI Two B-channel Transfer	RLT	Yes	NI-1 has a Release Link Trunk feature that is similar to PRI Two B-channel Transfer.
PRI with Semipermanent Packet	Yes	Yes	
Private Networking	Yes	No	NI-2 private networking not yet defined
Release Link Trunk	Yes	No	NI-2 has a PRI Two B-channel feature that is similar to Release Link Trunk.

### **B-channel Service Messaging**

The B-channel Service Messaging feature allows the central office and CPE to communicate with each other. This communication keeps B-channel states synchronized when there is a need to restore or remove a B-channel to or from service. The function for service messaging associated with a D-channel is automatically provided in the DMS-100 switch. To disable this feature requires datafill in table LTDATA and this feature can be disabled by interface. Service messages are mandatory for NI-1.

### **Call-by-call Service**

Call-by-Call Service on NI-2 PRI allows a PBX to use channels more effectively by increasing or decreasing the number of channels available to



each of the different call types. Therefore, more channels are made available to a specific call type during its busy hour. Both NI-1 and NI-2 support the concept of identifying the call type or service type separately from the channels available

Table 3-6 lists the call type that apply to NTNA (ISA) and NI (Call-by-Call).

**Table 3-6 Call-by-call and integrated service access**

Call type	NTNA (ISA)	NI (Call-by Call)
Private	Yes	No
Public	Yes	Yes
INWATS	Yes	Yes
OUTWATS	Yes	Yes
Tie	Yes	Yes
FX	Yes	Yes
Hotel/Motel	No	Yes
Selective Class of Call Screening (SCOCS)	No	Yes

### Call Forward/Interface Busy

Call Forward/Interface Busy (CFIB) provides the capability to forward calls to a remote directory number (DN) when the routelist to the base DN is busy. The term interface in this feature refers to the routelist entry in the routing tables. A routelist is considered busy when all routes in the routelist are call processing busy, out-of-service, or unavailable. In such situations, if the base DN subscribes to the CFIB feature, the call is redirected to a new DN, also known as the remote DN.

The targeted customers for CFIB are the internet service providers (ISP). One application of this feature is to forward the calls from a location in one time zone, whenever the routelist is busy, to another location in a different time zone where there may be less traffic. Another application of this feature is to provide a way to handle routing during disaster situations that cause the routelist to be unavailable.

### Calling Line Identification

Calling Line Identification services support the delivery, restriction, and blocking of calling number delivery services over PRI based on subscription parameters and each call privacy indicators.

### **Dialable Wideband Service**

Dialable Wideband Service is Nortel's multirate ISDN product. It is a switched service that provides flexible, wideband connectivity in the public-switched telephone network (PSTN). It offers a real-time switched service that allows the end user to establish network connections with rates from 128 kbit/s to 1.5 Mbit/s in 64 kbit/s increments. The bandwidth rate is selectable with each call.

### **E911 Preferred DN**

Primary Branch Exchange (PBX) users implement their own moves and changes of directory numbers (DN). The DN in the Public Safety Answering Point (PSAP) location may not be up-to-date or stored. The E911 Preferred DN feature ensures the PSAP receives the right DN from a National Integrated Services Digital Network (ISDN) Primary Rate Interface (PRI) trunk.

The E911 Preferred DN feature provides a default DN as the preferred DN or the user provided Calling Party Number (CPN) for 911 calls to the PSAP (if the CPN passes screening). The default DN option allows emergency personnel to arrive at a location close to the emergency. The emergency personnel contact directs the emergency personnel to the actual emergency location.

### **ISP Even Call Distribution**

ISP Even Call Distribution (AF7338) provides internet access providers (IAP) and internet service providers (ISP) a even distribution of calls across a set of possible trunk members. It provides support for a maximum of 220 PRI circuits in a PRI route list.

### **MSR Name Display and Universal DN System Support**

This feature (feature 59006512) provides for the display of the MSR name to the calling party when calls are routed to the an MSR for storage or retrieval. The feature also supports the Universal DN System when using the Base Message Waiting Indicator (MWI) Control Using NI-PRI feature.

A message services directory number is a DN associated with an MSR. A messages services DN routes calls to an MSR during message storage and retrieval. When user A calls user B, user B's name and number are displayed on user A's display equipment. If user B has redirected the call to a voice mail system, through the use of the MSR DN, user A's display shows the MSR name to which the call has been routed. Such a display also occurs when user B calls the voice mail system to retrieve the messages. The display shows the MSR name of the voice mail system that was called to retrieve the message

### **NCAS Framework**

The non-Call Associated Signaling (NCAS) Framework feature provides the signaling procedures for the control of supplementary services (for example,

message waiting indicator control) not associated with a call. This feature is in accordance with Section 10 of GR-28223-CORE, Issue 2, January 1996.

The NCAS Framework feature provides for signaling connections on Northern Telecom National ISDN Primary Rate Interface (NTNI PRI) links between Class 2 customer premises equipment (CPE) and a DMS-100 switch. These signaling connections do not require a circuit-switched (B-channel) connection.

### **Networked ACD on PRA**

The Networked Automatic Call Distribution (NACD) on PRA feature allows overflow routes or load sharing across different switches. The existing ACD groups remain the same, NACD provides a link between groups on different switches through table datafill. Communication is accomplished through the remote service operations element in SETUP, ALERTING, FACILITY, and REJECT messages. This feature is only supported with NI-1.

### **PRI Backup D-channel**

The PRI Backup D-channel feature supports a spare signaling channel on a second DS-1 facility for survivability purposes. If the primary D-channel fails, the signaling automatically transfers to a backup D-channel. The new channel assumes responsibility for both existing and new calls arriving over the PRI links. Provisioning rules for PRI Backup D-channel differ slightly between NI-1 and NI-2 variants.

### **PRI Base Service**

PRI Base Service provides the base features of ISDN PRI voice and data service. This feature establishes a PRI interface from the DMS-100 switch to another switching node at the far end. The interface is implemented on DS-1 links between the two nodes. The datafill for base service defines the hardware, trunks, and logical terminals involved in the PRI interface.

### **PRI Bearer Capability Routing**

The PRI Bearer Capability Routing feature enables the routing of ISDN calls based on the bearer capability (voice, 3 kHz audio, 56 kbit/s data, 64 kbit/s clear data).

### **PRI Call Routing**

PRI Call Routing provides the routing for calls over the PRI interface. This can be based on a variety of factors including the dialed number, the bearer capability, or call-by-call service identifiers. Routing and call throttling can also be accomplished using virtual facilities groups.

### **PRI Call Screening**

The PRI Call Screening feature supports NI-2 Calling Number (CGN) and Redirecting Number (RN), Privacy, Screening, and Billing. The design is

compliant with NI-2's TR-NWT-001187 (ISDN Calling Number Identification Services for Primary Rate Interfaces, Issue 1, March 1992, plus Revision 1, December 1994) this feature adds the following functionalities. CGN is also supported on the NI-1, or NTNA variant.

- CGN through interface screening for the NTNA variant
- CGN through interface screening for the NI-2 variant
- RN screening for the NI-2 variant
- RN privacy for the NI-2 variant
- RN billing for the NI-2 variant
- Correct CGN/RN and default calling number billing interactions for the NI-1 variant

### **PRI Calling Line Identification Blocking**

PRI Calling Line Identification Blocking consists of calling line identification (CLID) presentation and restriction. CLID presentation is a service offered to the called party to identify the origin of the call. The called party is provided with the ISDN number of the calling party.

CLID restriction is a service offered to the calling party. The calling party's ISDN number is not presented to the called party. The restriction can be for individual calls or for all calls.

### **PRI Calling Name Delivery**

ISDN PRI Calling Name Delivery provides the ISDN PRI called party with the calling party's name. The name is obtained in one of three ways.

- retrieved from a centralized name database using transaction capabilities application part (TCAP) messaging
- retrieved from the ISUP IAM message
- retrieved from a local table lookup

The TCAP portion of this feature is only supported within the variant National ISDN Primary Rate Interface (NI-PRI). Switch based name is supported on NTNA (NI-1) and NI-2PRI.

### **PRI Equal Access**

PRI Equal Access provides basic equal access end office (EAEO) translation capabilities for public calls originating on a PRI trunk. This capability provides transit network selection for public calls.

**PRI Flexible Timers**

The PRI Flexible Timers feature provides a mechanism for controlling ISDN PRI timers through a datafilled table. This independent control of the Q.931 layer 3 timers allows you to customize individual timers.

**PRI Hotel/Motel and Selective Class of Call Screening for NIPRI**

PRI Hotel/Motel (HM) and Selective Class of Call Screening (SCOCS) for NIPRI are originating services that allow the call originator, such as a PBX, to request an HM or SCOCS call from the PRI interface. The feature provides for corresponding translations and routing. SCOCS identifies a calling party as having special restrictions, such as inmate calls and coin calls.

**PRI ISDN Treatments**

The ISDN Treatments capability is made up of the audible treatment function. Audible treatment supplies inband tones and announcements for intercept treatments per logical terminal identifier (LTID). With audible treatment, when a speech or 3.1-kHz audio call is terminated to intercept treatment, the originating exchange returns a PROGRESS message to the terminating exchange and provides inband treatment. Without audible treatment, a DISCONNECT message, with cause, is returned and the call is terminated.

**PRI Message Waiting Indicator**

The PRI Message Waiting Indicator feature provides an indicator that a message has been left at a simplified message desk interface (SMDI) for busy or unavailable called parties.

**PRI Network Name Delivery**

The PRI Network Name Delivery feature is an NI-1 feature that delivers name information across a PRI network comprised of DMS Family switches including Meridian 1 PBXs. This capability also supports interworking with the CCS7 ISDN user part (ISUP) network. With interworking, the intermediate node does the protocol conversion. The following are the operational parts of the capability

- The retrieval of the calling party name (and that of the originally called party name, if redirection occurs) from the originating node. this information is transported across a network and delivered to the terminating node to be displayed on the terminating telephone.
- The retrieval of the connected party name from the terminating switch. This information is transported across a network and delivered to the originating node to be displayed on the originating telephone.
- Call redirection can occur at the terminating node while the originally called party's name is not present in the call establishment message from the originating node. In this case, the originally called party's name is retrieved from the terminating node's database and transported in the outgoing call establishment message.

### **PRI Originating Calling Name Delivery**

PRI Originating Calling Name Delivery is an originating feature that provides the called party (terminating agent) with the calling party's name when the call originates over a primary rate interface (PRI) trunk. Prior to this activity, integrated services digital network (ISDN) user part (ISUP) was the only originating trunk type that supported calling name deliver (CNAM). In NA009, feature activity AF7209 provided CNAM for terminating PRI trunks. This feature extends the CNAM functionality developed in activity AF7209 to originating (outgoing) PRI trunks.

The calling name is retrieved in one of two way:

- a centralized data base using transaction capabilities application part (TCAP) messaging
- a local table lookup

This enhancement affects the public network and is only supported by the NI-1 (NTNA), NI-2, 4ESS, and 5ESS PRI variants.

For intra-switch calls, the calling directory number (DN) is obtained from the calling party's DN on the switch. For inter-switch calls, the DN is obtained from the calling party number parameter of the ISUP initial address message (IAM). Transporting calling name information for inter-switch calls is dependent on Common Channel Signaling System No. 7 (CCS7) connectivity between the originating and terminating offices. The TCAP query with permission package provides a North American Numbering Plan (NANP) DN for use by the database to lookup the calling name information.

The centralized residence name database provides a name with a maximum of 15 characters in length and a permanent privacy indicator. The information retrieved by the database is passed to the terminating switch in a TCAP response package. The TCAP response is packaged and sent to the intelligent peripheral (IP) if all presentation conditions are met.

### **PRI Network Ring Again**

The PRI Network Ring Again (NRAG) feature is a non-standard mechanism that allows the ring again feature to work when the calling and called parties are on different switches connected by PRI trunks or a combination of PRI and CCS7 links. An end user located in any of the switching nodes in the combined PRI/CCS7 network can apply NRAG against a busy station located in any of the node in the same network and customer group.

This feature allows an end user who calls a busy station to queue against that station and be recalled when it becomes idle. When the end user accepts the recall, the original call is automatically set up again.

**PRI-PRI Over Multiple XPMs**

This feature removes the requirement to assign all B-channels of a primary rate interface (PRI) to the same XMS-based peripheral module (XPM) on which the D-channel resides. Distributed PRI allows a PRI to span more than one integrated services digital network (ISDN) equipped XPM.

Nortel supports this feature only for the Northern Telecom National ISDN (NTNI) PRI protocol variant.

**PRI SUSP for CNAME**

The PRI SUSP for CNAME feature completes the implementation of ISDN PRI Calling Name Delivery (I-CNAM). This feature enhances I-CNAM in four areas:

- provides SUSP billing
- supports AIN
- supports redirection
- supports CGN editing and CGN screening features

**PRI Two B-channel Transfer**

PRI Two B-channel Transfer (TBCT) on NI-2 PRI trunks allows customer premises equipment (CPE) to more efficiently use PRI trunk connections for ISDN calling traffic. In a PBX or network of PBXs, multiple call forward and transfer situations are typical. When a forwarded or transferred call is set-up using two channels in a PRI trunk to the DMS-100 system, the PRI trunk channels that were used to make the connection can be dropped and made available for future calls. Without Two B-channel Transfer, these channels would be available for the duration of the call, wasting telecommunications resources.

The Release Link Trunk (RLT) feature is the NI-1 equivalent of TBCT. These services are provisionable by interface. RTL is provisioned in table TRKGRP. RTL is provisioned in table LTDATA.

**Release Link Trunk**

This feature provides Release Line Trunk (RLT) on NTNA PRI trunks for the DMS-100 and SL-100 (North American Loads only). RLT optimizes the usage of PRI trunks when it is in effect. PRI Two B-channel Transfer is a similar feature provided for NI-2 PRI trunks.





---

# Part II

## Functional description

---

Part 2:, “Functional description” contains one chapter, “ISDN PRI functional description”.



---

## 4 ISDN PRI functional description

---

This chapter provides a brief functional description of ISDN PRI.

### Purpose of ISDN PRI

PRI provides ISDN access over 23 B-channels and one D-channel. Normally, PRI is used to create a logical private network by connecting ISDN switches, Meridian Digital Centrex (MDC) equipment, LANs, computers, and private branch exchanges (PBX), such as Meridian 1. With PRI, the B-channels carry voice and data at up to 64 kbit/s, and the D-channel carries out-of-band Q.931 signaling for one or more PRI links.

Increasingly, businesses are managing hybrid networks of public and private facilities. Northern Telecom's ISDN PRI implementation helps solve the connectivity and consistency problems inherent in these networks. Figure 4-1 illustrates a normal corporate ISDN network, showing PRI as an access connection between the DMS-100 switch and customer premises equipment (CPE), such as PBXs and LANs, and as a trunk interface between central offices. As shown in the diagram, Northern Telecom's PRI interworks with the Common Channel Signaling 7 (CCS7) protocol, providing transparent access to the CCS7 public network. For information about maintaining ISDN user part (ISUP) or CCS7 trunks, refer to *Advanced Maintenance Guide*.

Figure 4-1 A typical PRI network

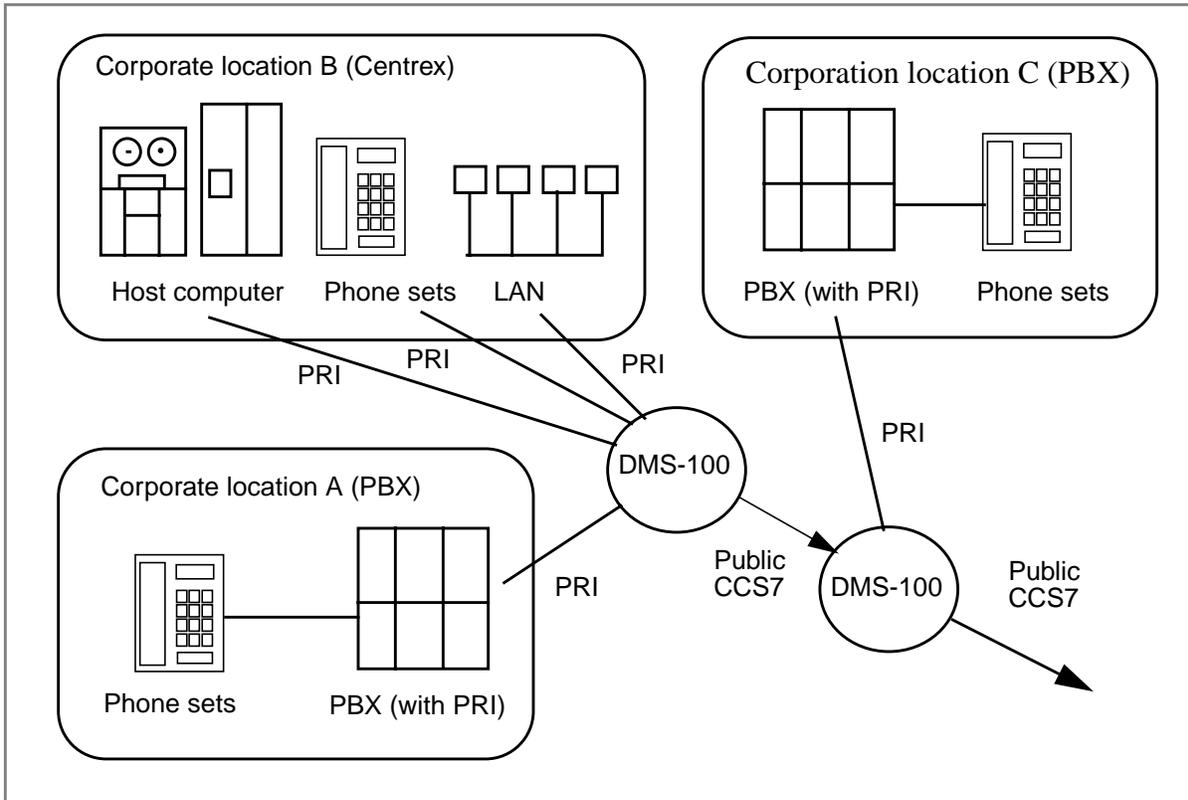

### ISDN PRI services

PRI provides access to the following services:

- circuit-switched voice and data
- integrated service access (ISA), which allows call-by-call service selection of a trunk type to accommodate changes in the types of trunk traffic throughout the day
- network-wide calling features

PRI does not provide a direct connection to the DMS packet handler (DMSPH) or the DPN packet handler.

### Signaling for PRI

PRI allows PBXs, interexchange carriers, and computers to be connected to the ISDN switch over digital trunks. PRI provides twenty-three 64kbit/s bidirectional B-channels, and one 64kbit/s D-channel. This signaling method is referred to as 23B+D signaling.

PRI uses a digital primary rate transmission facility. In North America, the DS-1 standard 1.544 Mbit/s 24-channel format is used to carry ISDN signals for PRI between the ISDN exchange termination and the PBX, such as the Meridian 1 Communications System.

One DS-1 link configured for PRI carries 24 channels. If one channel is used for the ISDN D-channel, the remaining 23 channels can be datafilled as PRI B-channels. One D-channel can support up to 479 B-channels, on a maximum of 20 DS-1 links, provided that all DS-1 links reside on the same ISDN peripheral. This capability is referred to as nB+D.

Nortel's PRI implementation provides a 64 kbit/s or 56 kbit/s D-channel. At the 64 kbit/s rate, the data stream is composed entirely of data (no bits are used for control information). If a 56 kbit/s DS-1 link is used, the B-channel and D-channel must also run at 56 kbit/s.

PRI works with a number of existing telephony agents, including

- POTS and MDC (lines and trunks)
- business sets, attendant consoles, and data units
- stimulus and functional signaling
- PRI PBX and intertoll trunks
- CAMA trunks
- equal access interexchange carrier (EAIEC) trunks
- Automatic Message Recording 5 (AMR5) trunks
- coin lines
- dialed loopback trunks
- operator trunks
- emergency service bureau (ESB) trunks

### **ISDN signaling methods**

DMS-100 ISDN supports two signaling methods to communicate between the subscriber's terminal and the switch: functional (Bellcore) and stimulus (Meridian feature transparency).

#### **Functional**

Functional signaling is based on a peer-to-peer exchange of information between an intelligent terminal and the network. This signaling method allows users to access network features and services, and makes ISDN standardization easier. Functional signaling is used for National ISDN-1 implementation, which conforms to Bellcore standards.

**Stimulus Meridian feature transparency**

Stimulus signaling provides a master/slave relationship between the network and the CPE. The terminal reports feature key activation to the network, and the network interprets the report and returns prompts (such as audible tones and indicator lamp states) to the CPE.

---

# **Part III**

## **Planning and engineering**

---

Part III: “Planning and engineering” contains the chapter: “Engineering and provisioning”.





---

## 5 Engineering and provisioning

---

This chapter describes ISDN PRI provisioning guidelines.

### Hardware

The DMS-100 uses common peripheral modules to serve ISDN PRI. If the common peripheral is only equipped to serve PRI, it is called an ISDN digital trunk controller (DTCI). D-channel handler (DCH) circuit packs are not required on the DTCI. If the module is equipped for both PRI and BRI, it is called a line trunk controller ISDN (LTC ISDN).

### DTCI

The XMS-based peripheral module product life upgrade strategy (XPM-PLUS) series 3 dual unit node ISDN digital trunk controller (DTCI) is an extended peripheral module integrated digital trunk carrier in which power and control for the 20 spans is performed from either of the two shelves. Unit 1 is the upper shelf. A quick summary working from left to right in Figure 5-1 shows peripheral DS1s at the far left, control and common cards in the center, and the C-side interface to the far right. DS1 numbering starts at span zero (0) located in unit 0, slot 5, port 0 to span 19, in unit 1, slot 1, port 1.

Figure 5-1 XPM-PLUS dual unit node DTCl

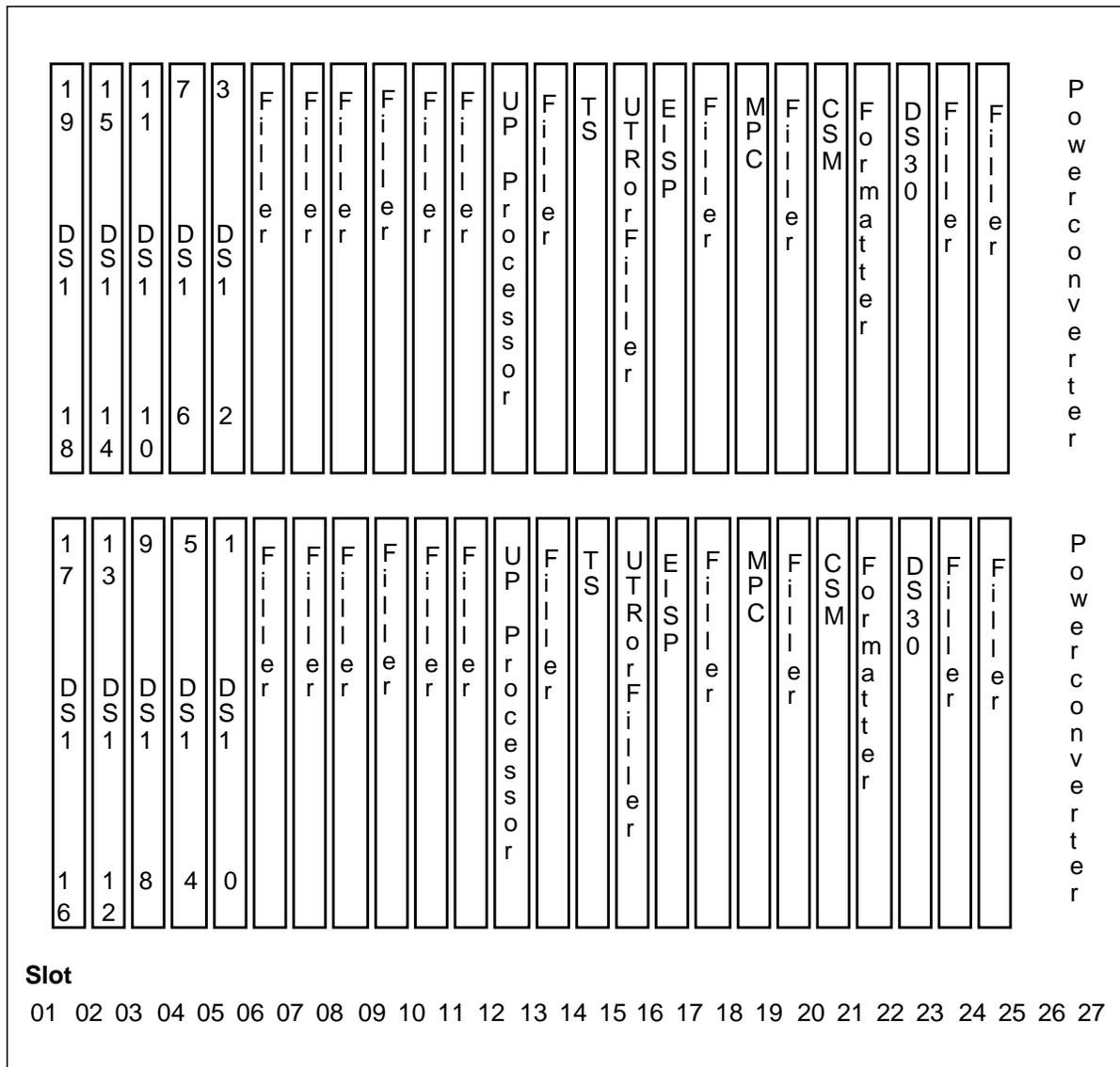

Table 5-1 shows the XMS-based peripheral module (XPM) circuit card list.

Table 5-1 XPM card list (Sheet 1 of 2)

Slot	Card code	Name	Purpose
1-5	NT6X50AB	DS1	Peripheral side interface
Others	NT0X50AA	Filler plate	Cosmetic
<b>Note:</b> Card codes are the latest version to date when this document was written.			

**Table 5-1 XPM card list (Sheet 2 of 2)**

Slot	Card code	Name	Purpose
12	NTMX77AA	UP	Processor
14	NT6X44AA	TS	Time switch
15	NT6X92BB	UTR	Universal tone receiver
16	NTBX01AB	EISP	Enhanced signaling processor D-channel
18	NT6X69AC	MPC	Message protocol and tone generator
20	NT6X42AA	CSM	C-side
21	NT6X41AA	Formatter	C-side
22	NT6X40FA	DS30	C-side interface 30 channels
25-27	NT2X70AE	power supply	Supplies power to unit

**Note:** Card codes are the latest version to date when this document was written.

## Software

Use the latest version of the XPM code (for example, XPM05) and the PRAB and ABTRK execs, as shown in table LTCINV. An example follows in the Customer datafill table flow section in this chapter. Use the peripheral module (PM) release document for specific software.

## Capacity

Consider the data in Table 5-2 when provisioning XPMs. Also, limit trunk groups using non-facility associated signaling to 10 T1 spans for each D-channel. If call durations are longer, add more spans. If call durations are short and rapid, decrease the number of spans.

**Table 5-2 XPM capacity**

Peripheral module DTCl (with M1 PBX)	Maximum capacity
XPM MP/SP (XMS-based extended peripheral module master processor/signaling processor)	12,000 calls per hour
XPM PLUS UP (XMS-based extended peripheral module product life upgrade strategy unified processor)	35,000 calls per hour

### Physical connections

Use the channel service unit (CSU) as a demarcation point only. The service provider is typically responsible up to and including the CSU, thus leaving the subscriber responsible beyond that point. Depending on the CSU type and manufacturer, conversion capabilities of different extended frame formats (ESF), superframes (SF), D4, monitor connections, and loop-backs can exist.

Use 24 AWG wire with transmit pairs and receive pairs in separate shields, usually in separate sheaths. Connect drain wires on one end only. The actual connection can be wire-wrap, DB-15, RJ-48, or Bantam jacks. The RJ-48 connectors are becoming more popular. PRI pin-outs are shown in Table 5-3.

**Table 5-3 PRI pin-outs**

Signal	Pin RJ-48	Pin DB-15	Network	CPE
R1	1	11	Rx Net->CSU	Tx CSU->DTE
T1	2	3	Rx Net->CSU	Tx CSU->DTE
R	4	9	Tx CSU->NET	Rx DTE->CSU
T	5	1	Tx CSU->NET	Rx DTE->CSU

### Customer datafill table flow

Figure 5-2 shows the PRI datafill table flow.

Figure 5-2 PRI datafill table flow

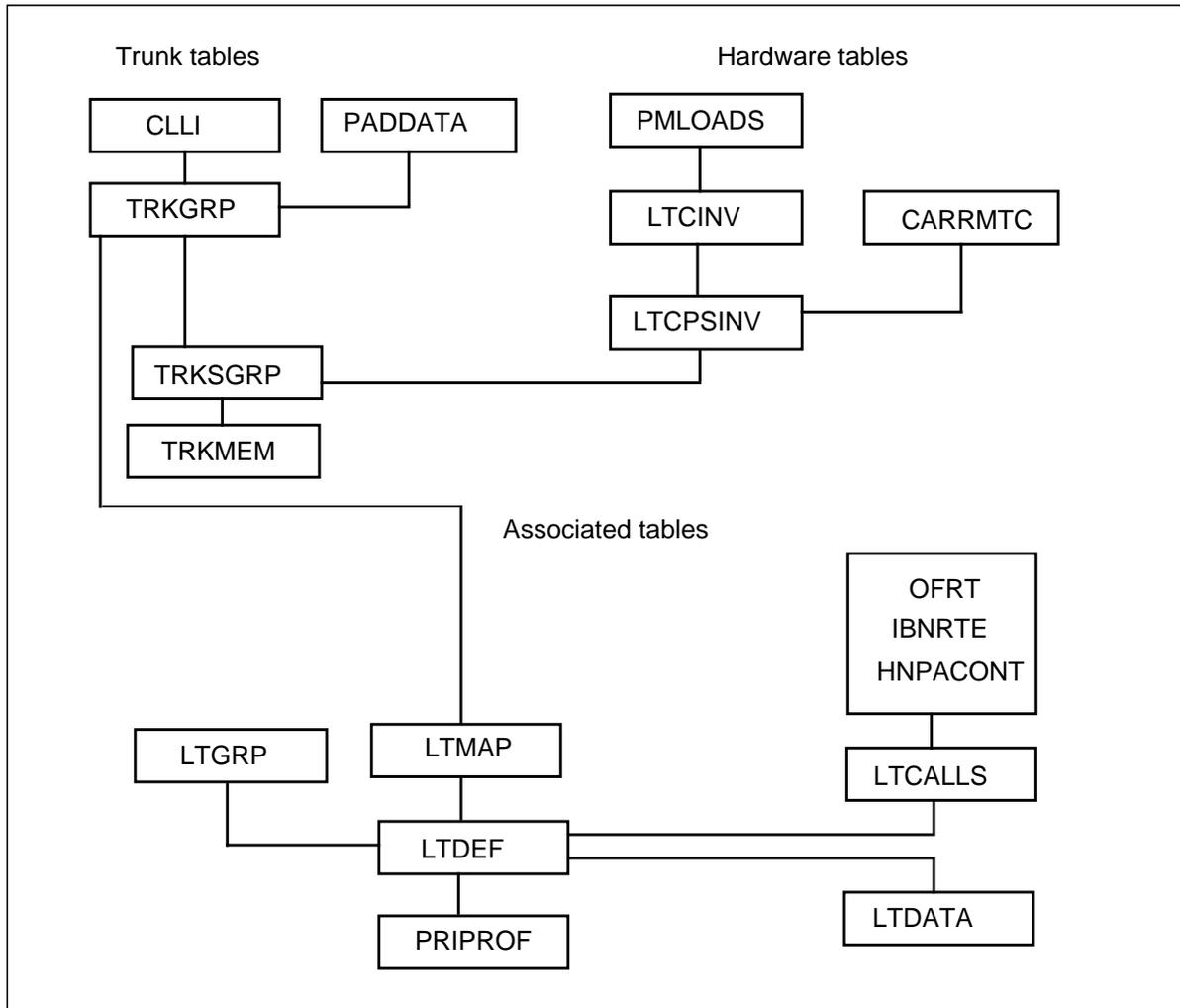

## Hardware datafill

Tables PMLOADS, CARRMTC, LTCINV, and LTCPSINV define the hardware. The tables must be filled in the order listed. Each table is described in the following sections.

### Table PMLOADS

Table peripheral module loads (PMLOADS) defines the location of the load for the PM, as shown in Figure 5-3.

**Figure 5-3 Example of table PMLOADS**

LOADNAME	ACTFILE	ACTVOL	BKPFIL	BKPVOL	UPDACT
ELI05BC					
ELI05BC	S01DPMLOADS				
ELI05BC	S00DPMLOADS				

Table 5-4 shows a description of the fields and settings in table PMLOADS.

**Table 5-4 Description of table PMLOADS**

Field name	Description	Setting
LOADNAME	Load name	Name found in table LTCINV
ACTFILE	Active file	Will search for this file first.
ACTVOL	Active volume	
BKPFIL	Backup file	The DMS switch searches for this if Active is not found.
BKPVOL	Backup volume	
UPDACT	Automatic update	Y (Yes). Load file is eligible for patching

**Table CARRMTC**

Table CARRMTC defines the characteristics of the carrier. Alarm and operational measurement (OM) thresholds are also set here. The majority of PRI links are set up, as shown in our example, with the following:

- extended superframe format (ESF) as the frame format
- binary 8 zero substitution (B8ZS) as the line coding, which differentiates a MARK and SPACE
- bipolar violations (BPV) indicates that BPVs are inserted in strings of consecutive spaces to keep repeater timing

In Figure 5-4, the values used are determined from experience. All outside plant and network paths must be set up for 64k. The 56k option exists but is rare.

**Figure 5-4 Example of table CARRMTC**

CSPMTYPE	TMPLTNM	RTSML	RTSOL	ATTR										
DTCI	64K	255	255	DS1	NT6X50AB	MU_LAW	ESF	B8ZS	CRC	NILDL				
				N	250	1000	50	50	150	1000	3	6	864	100
				17	511	4	255							
DTCI	DWS	255	255	DS1	NT6X50AB	MU_LAW	ESF	B8ZS	CRC	NILDL				
				N	250	1000	50	50	150	1000	3	6	864	100
				17	511	4	255							

Table 5-5 shows a description of the fields and settings in table CARRMTC.

**Table 5-5 Description of table CARRMTC**

Field name	Description	Setting
CSPMTYPE	Carrier peripheral module type	CSPMTYPE - Enter DTCI or LTC
TMPLTNM	Template name - Template name of peripheral module. This name is used in the CARRIDX subfield in table LTCPSINV.	TMPLTNM - 64KESF or DWS for dialable wideband service
RTSML	Route maintenance limit	RTSML - 255
RTSOL	Route out-of-service limit	RTSOL - 255
ATTR	DS-1 selector (SELECTOR)	SELECTOR - DS1
	Card name (CARD)	CARD - NT6X50AB
	Voice law (VOICELAW)	VOICELAW - MU_LAW
	Frame format (FF)	FF - ESF
	Line coding scheme (ZLG)	ZLG - B8ZS
	Bit error rate base (BERB0)	BERB - CRC
	Data link (DLK)	DLK - NILDL
	Inhibit alarm transmit (IAT)	IAT - N
	Local carrier alarm stop threshold (LCGAST)	LCGAST - 250
		LCGACL - 1000
	Local carrier group alarm clear threshold	RCGAST - 50
		RCGACL - 50

**Table LTCINV**

Table LTCINV defines the DTCl software load, executive programs, network links, and hardware cards present.

**Figure 5-5 Example of table LTCINV**

```

LTCNAME
  ADNUM  FRTYPE  FRNO  SHPOS  FLOOR  ROW  FRPOS  EQPEC  LOAD
                                     EXECTAB
                                     CSLNKTAB
                                     OPTCARD

  TONESET  PECS6X45
                                     E2LOAD
                                     OPTATTR

  PEC6X40                                     EXTINFO
-----
  DTCl  2
    7      LTE    0    51          1  D    0  6X02AA  ELI05BC
                                     (ABTRK DTCEX)(PRAB DTCEX)$
(0 12 1 0) (0 12 1 1) (0 12 1 2) (0 12 1 3) (0 12 1 4) (0 12 1 5)
(0 12 1 6) (0 12 1 7) (0 12 1 8) (0 12 1 9) (0 12 1 10) (0 12 1 11)
(0 12 1 12) (0 12 1 13) (0 12 1 14) (0 12 1 15) $
                                     (DCTAX78)(UTR15)(MSG6X69)(ISP16)$

  NORTHAM      MX77AA      MX77AA
                                     MX77NB0
                                     $

  6X40FA                                     N
    
```

Table 5-6 shows a description of the fields and settings in table LTCINV.

**Table 5-6 Description of table LTCINV (Sheet 1 of 2)**

Field name	Description	Setting
LTCNAME	Line trunk controller name - This field is used to describe the peripheral module type (XPMTYPE) and peripheral number (XPMNO).	XPMTYPE - Enter DTCl or LTC XPMNO - Enter a value between 0 to 255
FRTYPE	Frame type	FRTYPE - Enter DTE or SME
LOAD	Load name	LOAD - Enter the load name from the PMLOADS table



**Table 5-6 Description of table LTCINV (Sheet 2 of 2)**

Field name	Description	Setting
EXE	Terminal type (TRMTYPE) Executive program (EXEC).	TRMTYPE - PRAB for PRI trunks EXEC - Enter DTCEX
OPTCARD	Optional cards - The messaging card (MSG6X69) and the ISP signaling card (ISP16) are required for PRI operation.	OPTCARD - MSG6X69 and ISP16 DTCAX78 for dialable wideband

**Table LTCPSINV**

Table LTCPSINV assigns the DTCIs DS1 ports and references table CARRMTC.

**Figure 5-6 Example of table LTCPSINV**

LTCNAME	PSLNKTAB
-----	
DTCI 2	
N (0 DS1PRA DWS N 0 NIL) (1 DS1PRA DWS N 0 NIL)	
(2 DS1 DEFAULT N) (3 DS1PRA 64K N 0 NIL)	
(4 DS1PRA DEFAULT N 0 NIL) (5 DS1PRA 64K N 0 NIL)	
(6 DS1PRA 64K N 0 NIL) (7 DS1PRA 64K N 2 NIL)	
(8 DS1PRA 64K N 3 NIL) (9 DS1PRA 64K N 4 NIL)	
(10 DS1PRA 64K N 5 NIL) (11 DS1PRA 64K N 1 NIL)	
(12 DS1PRA 64K N 2 NIL) (13 DS1PRA 64K N 8 NIL)	
(14 DS1PRA 64K N 9 NIL) (15 DS1PRA 64K N 10 NIL)	
(16 DS1PRA 64K N 0 NIL) (17 DS1PRA 64K N 0 NIL)	
(18 DS1PRA 64K N 0 NIL) (19 DS1PRA 64K N 0 NIL) \$	

Table 5-7 shows a description of the fields and settings in table LTCPSINV.

**Table 5-7 Description of table LTCPSINV**

Field name	Description	Setting
LTCNAME	Line trunk controller name - This describes the peripheral module type and number	XPMTYPE - DTCl or LTC XPMNO - 0 to 255
PSLNKTAB	P-side table	
	P-side link (PSLINK)	Port number
	P-side data (PSDATA)	DS1PRA
	Carrier index (CARRIDX)	64k
	Action (ACTION)	N (do not remove the carrier from service if the maintenance thresholds are exceeded.)
	Interface identifier (IID)	0 to 31 see note below
	Line equipment (LINE_EQ)	NIL

Notice the following interface identifier (IID) conventions:

- IID 0 Span with primary D-channel
- IID 1 Span with backup D-channel
- IID 2 Spans with 24 B-channels in consecutive order

If the backup D-channel is not used, do not use IID 1.

Keep spans, IIDs, D-channels, B-channels in ascending order.

Figure 5-7 illustrates the importance of the IID. The IID specifies the span on which a channel is located. For example, the CPE wants to establish a call on channel 5 (time slot 5) on span 3. The CPE sends a setup message requesting channel 5 on interface 3 (IID 3). When the DMS switch receives a call, it receives the call on channel 5 (time slot 5) on the span specified as IID 3. If the DMS switch datafills this span as IID 2 instead of IID 3, the call does not have a path. The IID datafill values must match on both sides of the link.

Figure 5-7 Description of the interface identifier (IID)

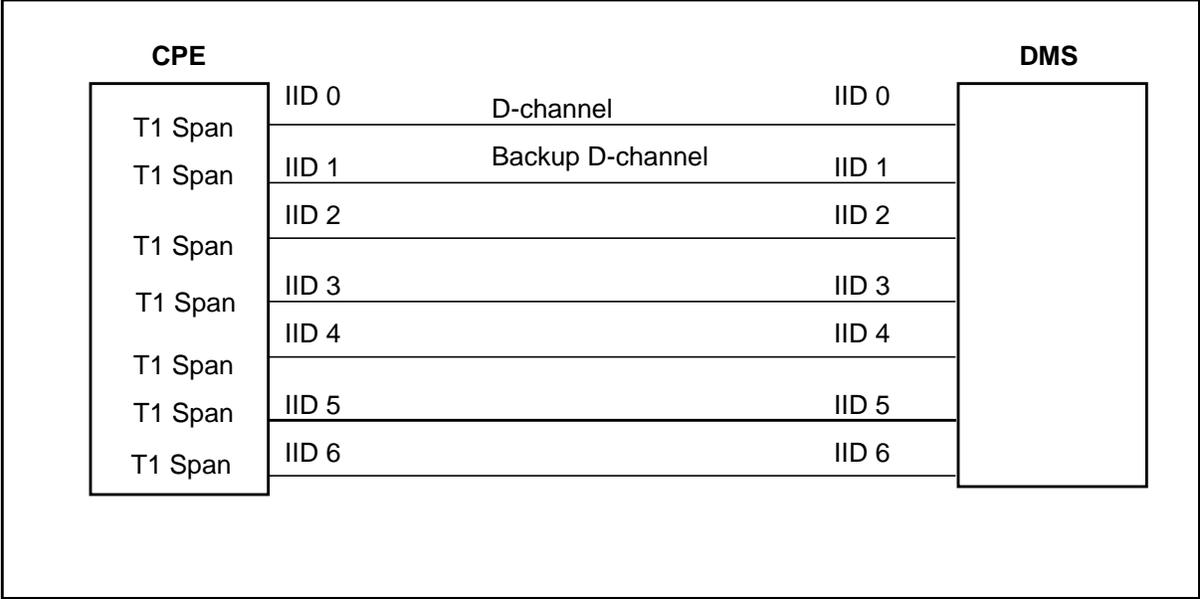



---

# Part IV

## Provisioning

---

Part IV: “Provisioning” contains the chapter:, “Data schema”.



---

## 6 Data schema

---

This chapter describes the data schema tables in the DMS-100 that are required to provide ISDN PRI services. Examples of table data, as seen on MAP (Maintenance and Administration Position) displays, are also provided

### Datafilling trunk tables

The procedures for datafilling PRI data schema tables are organized into the following four categories.

- Configuration tables define the PRI hardware requirements for the DTCL.
- Facility-related tables define the PRI trunk facilities associated with the DTCL.
- Service-related tables define the call routing services associated with PRI applications
- Associating tables associate the information in the configuration and facility-related tables with the information in the service-related tables.

#### **ATTENTION**

ISDN PRI translations errors can cause serious disruptions to service. Modifications such as protocol changes must be treated the same as when establishing new service. All parts of the affected service must be checked thoroughly for compatibility.

The tables in each category are discussed in the order in which they are datafilled. Only those fields that are specific to PRI are discussed. For a complete description of other fields, refer to Translations Guide, 297-8021-350.

Figure 6-1 shows the relationship of the PRI data tables.

Figure 6-1 PRI datafill table flow

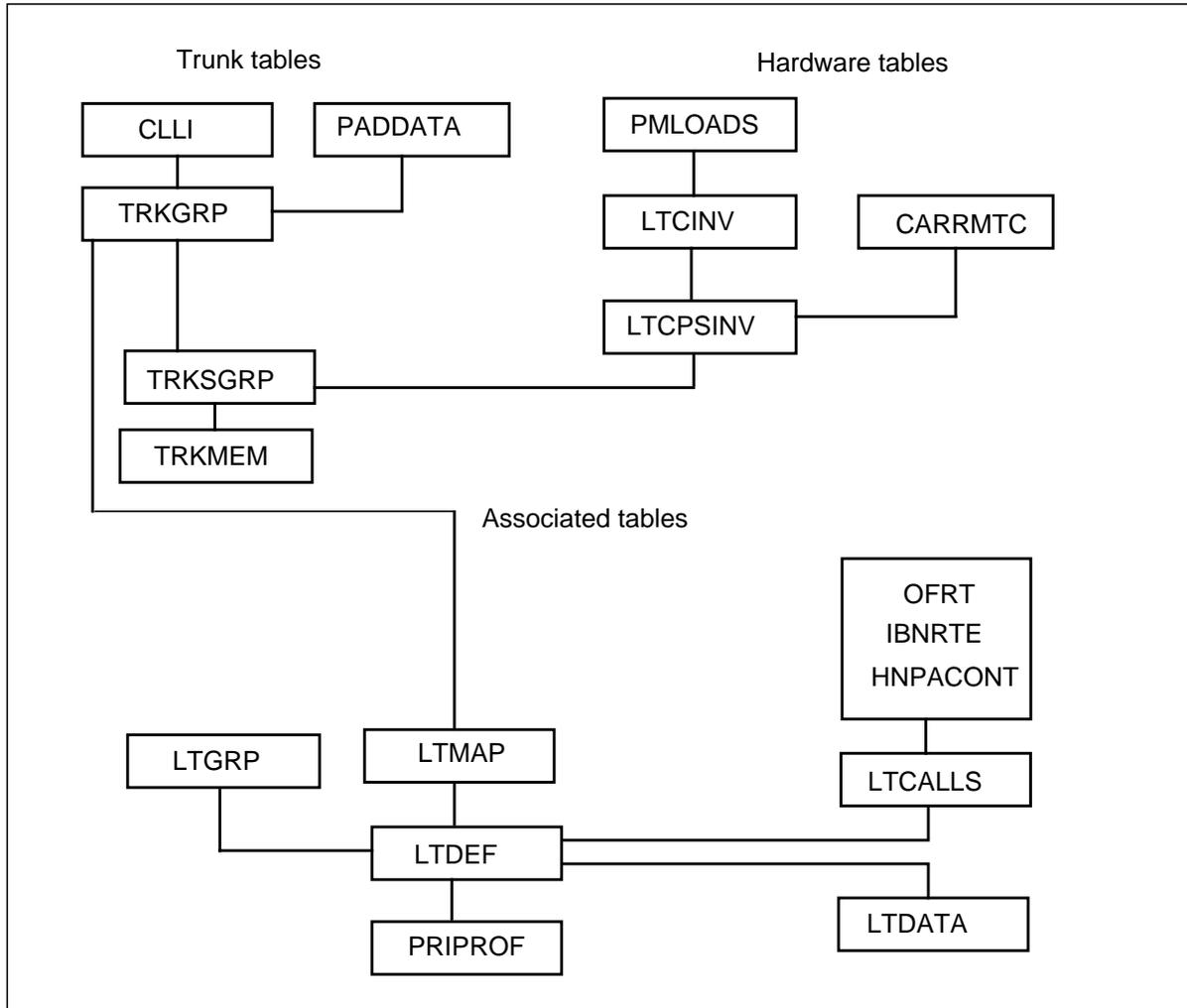



## Trunk tables

The following table lists the trunk tables and a brief description of their function.

**Table 6-1 Trunk tables**

Table	Description
CLLI	<p>The common language location identifier table identifies the name and size of the trunk group.</p> <p><b>Note:</b> Do not use the RENAMECLLI command to rename the PRI trunks used as PRI Public Safety Answering Point (PSAPS). A warning is issued when the PRI PSAP is placed in table E911PSAP to warn the user of this restriction.</p>
PADDATA	The pad data table is used for balancing line loss. ISDN PRI does not use this table.
TRKGRP	The trunk group table defines the trunk group type. The correct choices are PRA and IBNT2.
TRKSGRP	The trunk subgroup table contains supplementary information for each trunk group.
TRKMEM	The trunk member table specifies the physical location of each trunk assigned to one of the trunk groups.

## Hardware tables

The following table lists the hardware tables and a brief description of their function.

**Table 6-2 Hardware tables (Sheet 1 of 2)**

Table	Description
PMLOADS	The peripheral module loads table stores the device location of every PM load file. This table stores mapping between the load names and devices on which the loads reside. This arrangement permits the PM autoloading feature to locate load files without the intervention of operating company personnel
LTCINV	The line trunk controller inventory table contains the inventory data, except P-side link assignments, for host peripheral module (PM) types.

**Table 6-2 Hardware tables (Sheet 2 of 2)**

Table	Description
CARRMTC	The carrier maintenance table allows the DMS administration to datafill maintenance control information in peripheral modules (PM), out-of service limits for alarms, and system return-to-service occurrences.
LTCPSINV	The line trunk controller P-side link inventory table contains the assignment of the peripheral side (P-side) links for the peripheral modules (PM).

**Associated tables**

The following table lists the associated tables and a brief description of their function.

**Table 6-3 Associated tables**

Table	Description
LTGRP	The logical terminal group table associates the logical terminal group with the terminal type.
LTMAP	The logical terminal map table associates the logical terminal identifier (LTID) to a trunk group.
LTDEF	The logical terminal definition table defines the service profile of an LTID. It also indicates the protocol of the PRI (NTNAPRI or NIPRI).
PRIPROF	The PRI profile table establishes a PRI profile to be used for each interface.
OFRT	The office route table is used for storing route lists.
IBNRTE	The integrated business route table defines the customer group's IBN routes.
HNPACONT	The home numbering plan area control table lists all the home or serving area NPAs for a specific area.
LTCALLS	The logical terminal calls table associates service related data that the DMS switch associates with the call type.
LTDATA	The logical terminal data table stores service-related data associated with an LTID.

**Use of virtual facility groups to control trunk group size**

Table VIRTGRPS can be used to limit the size of trunk groups on an individual call type basis.

Tables STDPRTCT and STDPRT translate the call before normal translations. Nortel uses these tables to route the call to a VIRTGRP before normal translations. STDPRTCT has the name specified in table LINEATTR while table STDPRT routes on the dialed digits. Figure 6-2 shows the table flow for table STDPRTCT.

**Figure 6-2 Table flow for table STDPRTCT**

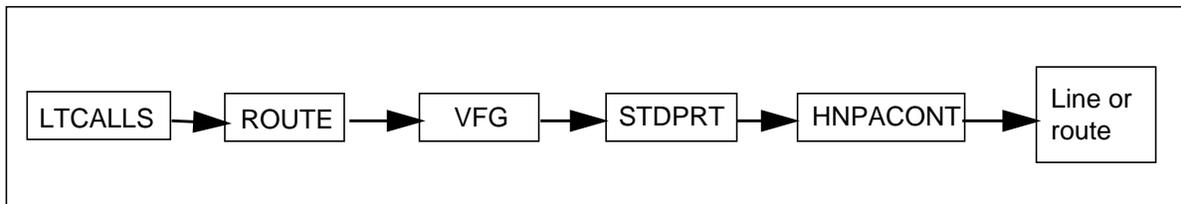

### Table STDPRTCT

Figure 6-3 shows an example of table STDPRTCT.

**Figure 6-3 Example of table STDPRTCT**

EXTPRTNM	STDPRT	AMAPRT
-----		
PBX	( 1)	( 0)

Figure 6-4 shows an example of table STDPRTCT:STDPRT.

**Figure 6-4 Example of table STDPRTCT:STDPRT**

FROMDIGS	TODIGS	PRETRTE
-----		
548	548	
	T DD 0	IBNRTE 1000 3 15 NONE
549	549	
	T DD 0	IBNRTE 1001 3 15 NONE
550	550	
	T DD 0	IBNRTE 1002 3 15 NONE
551	551	
	T DD 0	IBNRTE 1003 3 15 NONE

**Table STDPRTCT:STDPRT**

Table 6-4 shows a description of the fields and settings in table STDPRTCT:STDPRT.

**Table 6-4 Description of table STDPRTCT:STDPRT**

Field name	Description	Settings
FROMDIG	From digits	Enter the digit or digits translated. If the entry represents a block of consecutive numbers, enter the first number in the block.
TODIG	To digits	If field FROMDIGS represents a block of consecutive numbers, enter the last number in the block. Otherwise, the entry is equal to the entry in field FROMDIGS.
PRETRTE	Pretranslation route	Enter T since translations will route to another table.
	Type of call	Enter the type of call: DD (direct dial), NL (nil), NP (no prefix), or OA (operator assisted).
	Number of prefix digits	Enter the number of digits that are interpreted as prefix digits.
	Table identifier	Enter IBNRTE because this is the table name to which translation routes.
	Key	KEY - Enter the index into the IBNRTE table.
	Minimum digits received	Enter the minimum number of digits collected before routing the call.
	Maximum digits Received	Enter the maximum number of digits collected.
	Position	Enter the type of position in table POSITION that translation is routed to. Otherwise, the value of this field is NONE.

**Table VIRTGRPS**

Table VIRTGRPS limits the trunk group size and specifies the new LINEATTR for routing. Figure 6-5 shows an example of table VIRTGRPS.

**Figure 6-5 Example of table VIRTGRPS**

KEY	DATA	OPTIONS
BGRP1 SIZE	1 POTS 9022225804 300 Y	\$

Table 6-5 shows a description of the fields and settings in table VIRTGRPS.

**Table 6-5 Description of table VIRTGRPS (Sheet 1 of 3)**

Field	Subfield	Entry	Description
KEY		see subfield	Virtual facility group (VFG) key - Enter a user-defined VFG name.
	VIRTGRP	alphanumeric (1–6 characters or blank)	Virtual facility group. If the entry is the first entry for the VFG, enter a user-defined name. The addition of a tuple defines the name that is used in other tables that need VFGs. If the entry is not the first entry for the VFG, leave this field blank.
DATA		see subfields	Virtual facility group data. This field consists of subfields MEMBERS and INCTYPE.
	MEMBERS	see subfields	Virtual facility group members. This subfield consists of refinement VFGTYPE and subfields USESGRP and SIZE.
	VFGTYPE	SIZE, USES	Virtual facility group type. If this is the first entry for the VFG, enter SIZE. If this is not the first entry, enter USES.
	SIZE	0–2 048	Size. Datafill this refinement if the value of subfield VFGTYPE is SIZE. Enter the number of simultaneous accesses allowed for the VFG.

**Table 6-5 Description of table VIRTGRPS (Sheet 2 of 3)**

Field	Subfield	Entry	Description
	USESGRP	alphanumeric, nil	<p>Virtual facility users group name. Datafill this refinement if the value of VFGTYPE is USES. The VFG name is the name of the VFG specified in table VIRTGRPS.</p> <p>This entry provides the means to have virtual 2-way trunks or to associate more than one set of screening data with the same set of virtual circuits, or both. If the entry is not the first for the VFG, enter NILVFG.</p>
	INCTYPE	E911, IBN, NIL, POTS, or blank	<p>Incoming type. If this is the first entry for the VFG, enter one of the following:</p> <ul style="list-style-type: none"> <li>• Enter E911 to terminate 911 calls from an end office to an E911 tandem office through ISUP or super centralized automatic message accounting (SuperCAMA) trunks. The calls are translated to an E911 VFG and selectively routed to a primary public safety answering point (PSAP) based on the subscriber's DN.</li> <li>• Enter IBN if the call is entering the IBN translation environment.</li> <li>• Enter POTS if the call is entering the plain old telephone service translation environment.</li> </ul>
	BILLNUM	numeric (vector of up to 11 digits) or N	<p>Billing number. Enter the 10-digit billing number to which the next leg of the call is charged. If the call is charged to the originators billing number for the next leg of the call, enter N.</p>
	LINEATTR	0–4 095	<p>Line attribute index. Enter the line attribute index that specifies the translations and screening tables used for the next leg of the call.</p>
	LINECDR	Y, N	<p>Line call detail recording. Enter Y if CDR is required to record virtual line type calls. Enter N if CDR is not required.</p>

Table 6-5 Description of table VIRTGRPS (Sheet 3 of 3)

Field	Subfield	Entry	Description
OPTIONS		see subfield	OPTION - EA (To indicate Equal Access.)PIC - Enter the name assigned to the primary inter-LATA carrier (PIC) in table OCCNAME.CHOICE - Enter Y if the caller is allowed to dial a 10XXX prefix to choose a carrier manually. Enter N if the caller is not allowed.
	OPTION	CUSTGRP, EA, ENTRYID, IBNPIC, INTPIC, LPIC, PRIBILDN, SPBDN, RC, TBO, TOLLRST, VFGALSC, VFGAMA, VFGLSC	Option. Enter EA and datafill subfields PIC and CHOICE.
	PIC	alphanumeric (1-16 characters)	Primary inter-LATA carrier. Enter the name assigned to the primary inter-LATA carrier (PIC) in table OCCNAME. Enter NONE if a PIC is not required.
	CHOICE	Y, N	Choice. Enter Y, if the caller is allowed to dial a 10XXX prefix to choose a carrier manually.

## Datafilling tables for specific features and services

The following section describes the datafilling of tables for specific ISDN PRI features and services.

### B-channel service messaging

Nortel proprietary PRI uses service messages to communicate channel states. National ISDN (NIPRI) omits service messages from the specification, leaving algorithms to determine channel states. These algorithms cause mismatched channel states between the central office (CO) and the CPE. Nortel provides service messages on NIPRI as an option. If the CPE supports service messages, Nortel recommends using them. This is also the default option. If the CPE does not support service messages, Nortel recommends using option NO\_B-Channel\_Service Messages.

The datafill for No Service Messaging is an option in table LTDATA, shown in the example below. Notice that this is only for NIPRI.

**Figure 6-6 Example of data in table LTCDATA**

```
ISDN 95 SERV
SERV Y Y ALWAYS ALWAYS (NO_BCH_SERV) $
```

**Call-by-call translations**

All PRI trunk groups have similar datafill processes. The first step is to build the trunk group and then build standard routes. The application determines the features and the enhancements to routing. In the illustrations in this document, Nortel uses an M1 PBX as the application. The other applications use a subset of these translations.

**Call routing translations**

All incoming and outgoing ISDN PRI calls use the same basic translations. PRI call routing uses some additional tables, such as LTCALLS and LTOPT. The call-by-call (sometimes called Integrated Services Access[ISA]) feature uses messaging on the D-Channel to custom route each call based on call type (public, private, TIE, WATS). If the DMS switch does not use the call-by-call feature, all incoming and outgoing calls default to being public calls.

Use table LTCALLS as the primary table to route incoming calls based on call type. For outgoing calls, use the ISA selector to define the call type. Use the ISA selector in the following tables: OFRT, HNPACONT:RTEREF, and IBNRTE.

Various TRAVER examples in this document demonstrate routing. Figure 6-7 shows an example of standard routing.

**Figure 6-7 Standard routing**

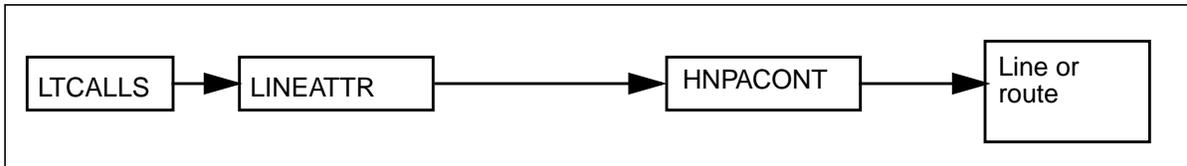

Table HNPACONT:RTEREF sets the outgoing route. Notice that tables OFRT and IBNRTE datafill exactly as RTEREF and are in use for private routing. Figure 6-8 shows an example of table HNPACONT:RTEREF.



**Figure 6-8 Example of table HNPACONT:RTEREF**

RTE	RTELIST
902	( ISA N N N PRI14 PUB NONE N N 0)\$
905	( ISA N N N PRI14 FX 0 E164 0)\$
906	( ISA N N N PRI14 FX 0 PVT 0)\$
907	( ISA N N N PRI14 TIE 0 E164 0)\$
908	( ISA N N N PRI14 TIE 0 PVT 0)\$
909	( ISA N N N PRI14 INWATS 0 E164 0)\$
910	( ISA N N N PRI14 INWATS 0 PVT 0)\$
1005	( VFG N N N ERIC 33)\$

**Note:** Private call type is not valid on PRI trunks that use NIPRI protocol.  
Hotel/Motel Selective Class of Call Screening (SCOCS) is not supported on NTNA.

Table 6-6 provides a description of the fields and settings in table HNPACONT:RTEREF.

**Table 6-6 Description of table HNPACONT:RTEREF (Sheet 1 of 2)**

Field	Description	Settings
RTE	IBN route reference Index	RTE - Enter the route reference number assigned to the route list.
RTELIST	IBN route selector	IBNRTSEL - VFG (Enter VFG for VFG route selector. Enter ISA for ISA route selector.)
	Off-hook queuing	OHQ - N (Enter Y if off hook queuing is required for the virtual facility group or the ISA routing.)
	Callback queuing	CBQ - N (Enter Y if call back queuing is required for the virtual facility group or the ISA routing.)
	Expensive route	EXP - N (Enter Y if an expensive route and expensive route warning tone is to be applied.)
	Virtual facility group	VFG - Enter the name of the VFG to which translation routes. This subfield is only applicable if the VFG route selector is entered.
	Common language location identifier	CLLI - Enter the CLLI of the PRI trunk group to which translation has to route. This subfield is only applicable if the ISA route selector is entered.

**Table 6-6 Description of table HNPACONT:RTEREF (Sheet 2 of 2)**

Field	Description	Settings
	Call type (CALLTYPE),	CALLTYPE - PUB for public network calls CALLTYPE - OW For OutWats CALLTYPE - INWATS for INWATS CALLTYPE - TIE for Tie Line trunks CALLTYPE - PVT for private network calls (Not valid on PRI trunks using NIPRI protocol) CALLTYPE - FX for foreign exchange calls <b>CALLTYPE - MH for hotel/motel service (NI-2 only)</b> CALLTYPE - SCOCS for selective class of call screening (NI-2 only)
	Transit network selection	TNS - (Enter N if no TNS is required. If the TNS is determined from the calls originator, enter C.
	Number identification	NPOS - N (Enter N if calling number identification is required for ONI or ANI-failure calls from SC/TOPS trunks. Enter Y if no calling number identification is required.
	Operator access type	OATYPE - NONE (Enter the type of operator access that is required on this call. Options: None, OP and OM.
	WATS zone number	ZONE- OUTWATS Zone Number
	Facility Number	FACNUM - Enter the facility number to be included in the NSF information element. This is also called a SID.
	Numbering Plan Indicator	NPI - PVT for private numbering plan or E164 for the E.164 numbering plan.
	Digit Manipulation Index	DMI - Enter the index into table DIGMAN used to convert the dialed digits to a new set of digits which are then retranslated to route the call to the desired destination.

Tables HNPACONT, HNPACODE, and RTEREF review the dialed digits, index the route, and then send the call to completion. Figure 6-9 shows an example of table HNPACONT.

**Figure 6-9 Example of table HNPACONT**

STS	NORTREFS	NOAMBIGC	RTEREF	HNPACODE	ATTRIB	RTEMAP
902	911	2	( 51)	( 1)	( 0)	( 0)

Figure 6-10 shows an example of table HNPACONT:HNPACODE.

**Figure 6-10 Example of table HNPACONT:HNPACODE**

FROMDIGS	TODIGS	CDRRTMT
800	800	
	HRTE	902
801	809	
	HRTE	1005

Table 6-7 shows a description of the fields and settings in table HNPACONT:HNPACODE.

**Table 6-7 Description of table HNPACONT:HNPACODE**

Field	Description	Settings
FROMDIG	From digits	FROMDIG - Enter a string if the leading three digits represent an office code within the home numbering plan area (HNP). This number represents either a single code or the first in a block of consecutive codes that have the same input data.
TODIGS	To digits	TODIG - If field FROMDIGS represents a single code, enter the same single code as in the field FROMDIGS. If field FROMDIGS represents the first number of a block of consecutive numbers, enter the last number of the block.
CDRRTMT	Code type, route reference, and treatment - This field consists of subfield code type (CD).	CD - LRTE (Enter LRTE for Local Route.) RR - Enter the route reference index of the route list in subtable HNPACONT: RTEREF (at the same position service numbering plan area as this subtable) to which translation proceed.

Table LINEATTR sets the attributes of the line. This location is where you define the pretranslator and the HNPACONT index. Figure 6-11 shows an example of table LINEATTR.

Figure 6-11 Example of table LINEATTR

```

LNATTIDX LCC CHGCLSS COST SCRNCL LTG STS PRTNM LCANAME ZEROMPOS TRAFSNO
MRSA SFC LATANM MDI IXNAME DGCLNAME FANIDIGS
RESINF
                                OPTIONS
-----
  300  PBX  NONE NT NSCR   0 902 PBX  NLCA  NONE  0
NIL NILSFC NILLATA 0 NIL   NIL   00
      N
                                $
    
```

Table 6-8 provides a description of the fields and settings in table LINEATTR.

Table 6-8 Description of table LINEATTR (Sheet 1 of 4)

Field	Subfield	Entry	Description
LNATTIDX		numeric (0–31 999)	Line attribute index. Enter the index into table LINEATTR.
LCC		alphanumeric (up to 8 characters) or NLCC	Line class code (LCC). Enter the LCC assigned to the line attribute index. The LCC of an existing tuple cannot be changed. If there is no LCC, enter NLCC.
CHGCLSS		CAM0, CAM1, CAM2, CAM3, CSD0, DAT0, DAT1, DAT2, DAT3, DIHS, DLHS, DLLS, INW0, LAM0, LCDR, MBG, NONE, RCFW, SPCL, TRMB, TWX0, WAT0	Charge class. Enter the charge class assigned to the line attribute index. Otherwise, enter NONE.  <b>Note:</b> With Bellcore CDE format, the entry is NONE except in offices with the Overseas Operator Center (OOC): AMA Modernization feature.
COST		HI, LO, NT	Class of service tone. (Enter Class of service tone; NT for No Tone, HI for high tone, and LO for low tone.)
SCRNCL		alphanumeric (up to 4 characters) or NSCR	Class of service screening. Enter NSCR if screening by class of service is not required. If screening by class of service is required, enter the name of the class of service subtable assigned to the line attribute index.

Table 6-8 Description of table LINEATTR (Sheet 2 of 4)

Field	Subfield	Entry	Description
LTG		numeric (0–9 998)	Line treatment group. Enter the line treatment group number assigned to the line attribute index. The line treatment group number discriminates between customer lines assigned to the same line class code but with different routing or screening patterns.
STS		numeric (up to 3 digits)	Serving translation scheme (STS). Enter the serving numbering plan area (NPA) assigned to the line attribute index. The STS of an existing tuple cannot be changed.
PRTNM		alphanumeric (up to 4 characters) or NPRT	Standard pretranslator subtable name. Enter the name of the standard pretranslator subtable assigned to the line attribute index, if pretranslation of digits is required. If standard pretranslation is not required, enter NPRT
LCANAME		alphanumeric (1–8 characters) or NLCA	Local calling area screening subtable name. Enter the name of the local calling area subtable assigned to the line attribute index if screening of local central office codes is required. If screening of local NNX codes is not required, enter NLCA.
ZEROMPOS		alphanumeric (up to 10 characters) or NONE	Zero minus position. Enter the position in the position table to which operator (0-) calls are routed if a line attribute is configured for operator (0-) and special toll (0) dialing,. Otherwise, enter NONE.
TRAFSNO		numeric (0–127)	Traffic separation number. Enter 0 if a traffic separation number is not required. Otherwise, enter the source and destination traffic separation number [1 to 127] assigned to the line attribute index.

**Table 6-8 Description of table LINEATTR (Sheet 3 of 4)**

Field	Subfield	Entry	Description
MRSA		alphanumeric (up to 8 characters) or NIL	Message rate service area. Enter NIL if multiunit message rate [MUMR] services billing records are not required. If MUMR billing records are required for calls to numbers resulting in a type of call of NP (no prefix), enter a message rate service area (MRSA) name as datafilled in table MRSANAME field MRSA.
SFC		alphanumeric (up to 6 characters) or NILSFC	International subscriber feature class. Enter NILSFC if the switching unit does not have an international load.)
LATANM		alphanumeric (up to 8 characters)	Local access and transport area name. Enter the name of the local access and transport area assigned to the line attribute index.
MDI		numeric (0–1 023)	Metering data index. Enter 0 if the switching unit does not have an international load.)
IXNAME		see subfields	International translations system start. his field consists of subfield XLASYS and XLANAME.
	XLASYS	AC, AM, CT, DN, FA, FT, OFC, NSC, PX, NIL	International translations system. If the switching unit has an international load, enter the head table name where translation starts, and datafill refinement XLANAME. For loads that are not international, enter NIL and leave refinement XLANAME blank.  For an MDC equipped with the Open Number Translations feature, enter PX to direct the call to the translator name specified in refinement XLANAME. Translation selector NET, network type DOD must be datafilled in table IBNXLA. If the entry is other than PX or NIL, a DFIL117 log is generated and the call is sent to call

Table 6-8 Description of table LINEATTR (Sheet 4 of 4)

Field	Subfield	Entry	Description
DGCLNAME	XLANAME	alphanumeric (1–8 characters)	International translations name. Enter the index into the head table referenced by field XLASYS.
		alphanumeric (up to 8 characters) or NIL	Digit analysis tables entry point. Enter NIL if the switching unit does not have an international load. If the switching unit has an international load, enter a digit analysis name to serve as the entry point into the universal digit analysis tables DGHEAD and DGCODE.  The name entered here must appear in table DGHEAD field DGNAME.
FANIDIGS		numeric (00–99)	Flexible ANI information digit pairs. Enter the flexible automatic number identification [FANI] information digit pair assigned to the line attribute index if the switching unit is equipped with the Flexible ANI Information Digit Assignment feature. Otherwise, enter 00.
RESINF		see subfields	Residential enhanced services information. This field consists of subfield RESINFO and refinements CUSTGRP, SUBGRP, and NCOS.
	RESINFO	Y, N	RES information selector. Enter N if the line attribute is not required to support RES lines. Leave refinements CUSTGRP, SUBGRP, and NCOS blank.

Table LTCALLS sets the routing on a call type and numbering plan. A tuple must exist for every call type, otherwise the DMS switch rejects the call. This allows for different routing based on different call type. Figure 6-12 shows an example of table LTCALLS.

**Figure 6-12 Example of table LTCALLS**

LTID		XLARTSEL		OPTIONS	
ISDN	150 PUB	XLAL	EC 300		(EA MCI222 Y)\$
ISDN	150 INWATS	XLAIBN	300	ISDN2	0 0 (INCLID SUPPRESS)\$
ISDN	150 WATS	XLAIBN	300	ISDN2	0 0\$
ISDN	150 FX	XLAIBN	300	PBXGROUP	0 0 (SIDXLA PRIFX Y Y N)\$
ISDN	150 TIE		RTEREF	IBNRTE	1007 \$

Table 6-9 provides a description of the fields and settings in table LTCALLS.

**Table 6-9 Description of table LTCALLS (Sheet 1 of 4)**

Field	Subfield	Entry	Description
LTID		see subfields	Logical terminal identifier. This field consists of subfields LTGRP[, LTNUM, and CALLTYPE.
	LTGRP	alphameric (up to 8 characters)	Logical terminal group. Enter the logical terminal group name.
	LTNUM	1-1022	Logical terminal number. Enter the logical terminal number within the group.
	Call type	ASDS, FX, HM, INWATS, LDS, PUB, PVT, SCOCS, TIE, WATS,	<p>Call type. Enter the call type associated with the LTID. The DMS switch can associate more than one type with the same identifier. Select from the following list of call types.</p> <ul style="list-style-type: none"> <li>ASDS (Accunet Switched Digital Service) is an integrated services access (ISA) route selector used to route AT&amp;T Accunet CALLS.</li> <li>FX (foreign exchange) provides a subscriber's location with the equivalent of local service from a distant exchange.</li> <li>HM (hotel/motel) provides for hotel/motel services.</li> </ul>



Table 6-9 Description of table LTCALLS (Sheet 2 of 4)

Field	Subfield	Entry	Description
			<ul style="list-style-type: none"> <li>• INWATS (Inward Wide Area Telecommunications Service) is a form of long distance service that allows a subscriber to receive calls originating within specified service areas, without a charge to the caller.</li> <li>• LDS (long distance service) is an ISA route selector used to route AT&amp;T world connect (international) calls.</li> <li>• PUB (public). A carrier can provide this call type.</li> <li>• PVT (private) provides private telephone services to a specific organization.</li> <li>• SCOCS (Selective Class of Call Screening) is an originating-only service that allows several distinct classes of service to be associated with a single PRI.</li> <li>• TIE (tie line) is a type of call that occurs on private lines between PBXs.</li> <li>• WATS (Wide Area Telecommunications Service) is provide by operating companies to permit subscribers to make calls over an access line to telephones in a specific zone.</li> </ul>
XLARTE	XLARTE	RTEREF, IBNRTE, XLAIBN, XLALEC	<p>Translations route. Enter one of the following translations routes.</p> <ul style="list-style-type: none"> <li>• RTEREF if translation is done by a specific table and index, such as OFRT, IBNRTE, and other routing tables</li> <li>• IBNRTE to indicate IBN route</li> <li>• XLAIBN for integrated business network (IBN) translations. This selection is used only in PBX or centrex offices.</li> <li>• XLALEC for local exchange carrier translations, such as plain old telephone service (POTS), or in PBX or centrex type offices. If the entry in subfield CALLTYPE is PVT, INWATS, or TIE the switch requires no other data.</li> </ul>

**Table 6-9 Description of table LTCALLS (Sheet 3 of 4)**

Field	Subfield	Entry	Description
OPTIONS			The entry of XLARTE - XLAIBN selection allows routing of the outgoing call to be altered such that the LINEATTR selected with the XLAIBN route selector is used for basic call screening only.
	LINEATTR	0-31 999	Line attributes index. Enter the index into table LINEATTR  for service-related data.  INDEX - The number of the route in the IBNRTE table.
	CUSTGRP	alphanumeric (up to 16 characters)	Customer group name. Enter customer name associated with an IBN station.
	SUBGRP	0-7	Subgroup number. Enter the subgroup number that further defines the selection of the CUSTGRP.
	NCOS	0-511	Network class of service. Enter the network class of service (NCOS) that determines the facilities to which the network user has access.
		EA, INCLID, LPIC, SIDXLA	Options - This field consists of subfield logical terminal option (LTCOPT) and refinements router name (RTRNAME), treatment with no service Identifier (TREAT_NO_SID), no call screen (NO_CALL_SCREEN), and route on translations route (ROUTE_ON_XLARTE).  LTOPT - SIDXLA (Enter SIDXLA to allow service identifier OUTWATS Banded call type.)

Table 6-9 Description of table LTCALLS (Sheet 4 of 4)

Field	Subfield	Entry	Description
			<p>RTRNAME - Enter the OUTWATS router name built in table ISAXLA for routing OUTWATS Banded Service.</p> <p>TREAT_NO_SID - Y (This field determines whether calls without an associated service identifier should be sent to treatment. Enter Y to indicate that the call should be sent to treatment. Enter N to route the call using the numbering plan indicator, network specific facility, and the called digits.)</p> <p>NO_CALL_SCREEN - Y (This field allows call screening on the line attribute index to avoided. Enter Y to indicate that validation is not done on the directory number. Enter N to indicate that call screening is done using the line attribute index defined in field LINEATTR.)</p> <p>ROUTE_ON_XLARTE -Y (This field determines whether a call is routed through public or private translations based on the entry in field XLARTE rather than the NPI in the setup message. Enter Y to indicate that the XLARTE overrides the NPI. Enter N to indicate that the NPI determines the type of translation.)</p>

### Call type significance

The call type is conveyed between switches by the setup protocol message. For PRI, the call type determines the translations that are used to route an incoming call. there is no global significance to the call type at any certain point. the call type is significant only to the local PRI. Once inside the next exchange, it is discarded and subsequent legs of the same call can have different call types. As an example of call type, most data applications use public-switched networks; therefore, only use the public call type. Figure 6-13 shows an example of a public-switched network.

Figure 6-13 Public-switched network

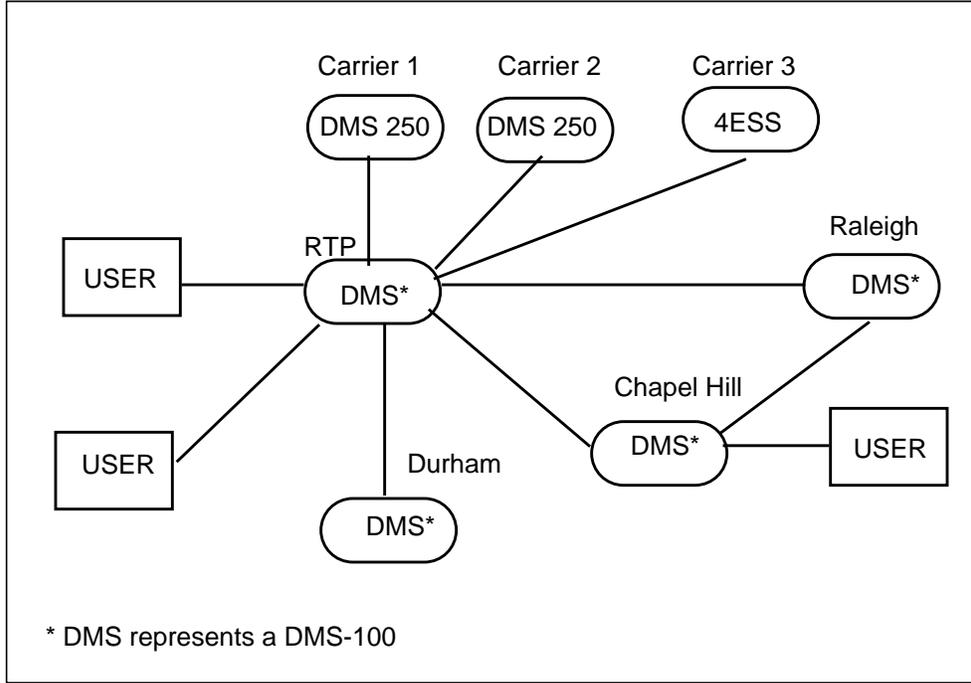

The PUB call type is used for the everyday numbering plan, which usually consists of a 1 + 7 digit local directory number, and 10 CAC + 1 800 dialing to get to the destination.

Subscribers who normally connect their equipment with dedicated lines (shown by the dashed lines in Figure 6-14), use the TIE call type to use subscriber-specific features. The private call type replaces the TIE call type. Figure 6-14 shows an example of a tie line.

Figure 6-14 Tie line

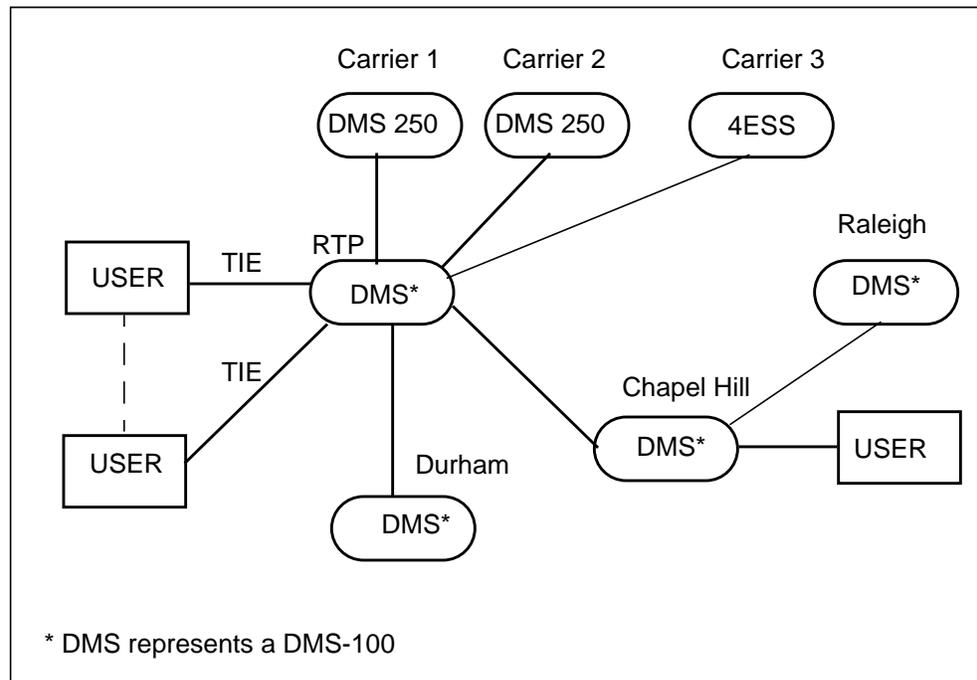

Use the FX call type to connect foreign exchanges (central offices). In Figure 6-15, RTP is the central office (CO). Raleigh, Chapel Hill, and Durham are COs in adjacent cities. The subscribers subscribe to a foreign exchange so they can make calls and receive calls from any of these cities as local calls (calls with no charges). Before PRI, a dedicated line ran from each CO to the PBX. With PRI, an FX call type uses the same PRI span. Figure 6-15 shows an example of foreign exchange lines.

**Figure 6-15 Foreign exchange lines**

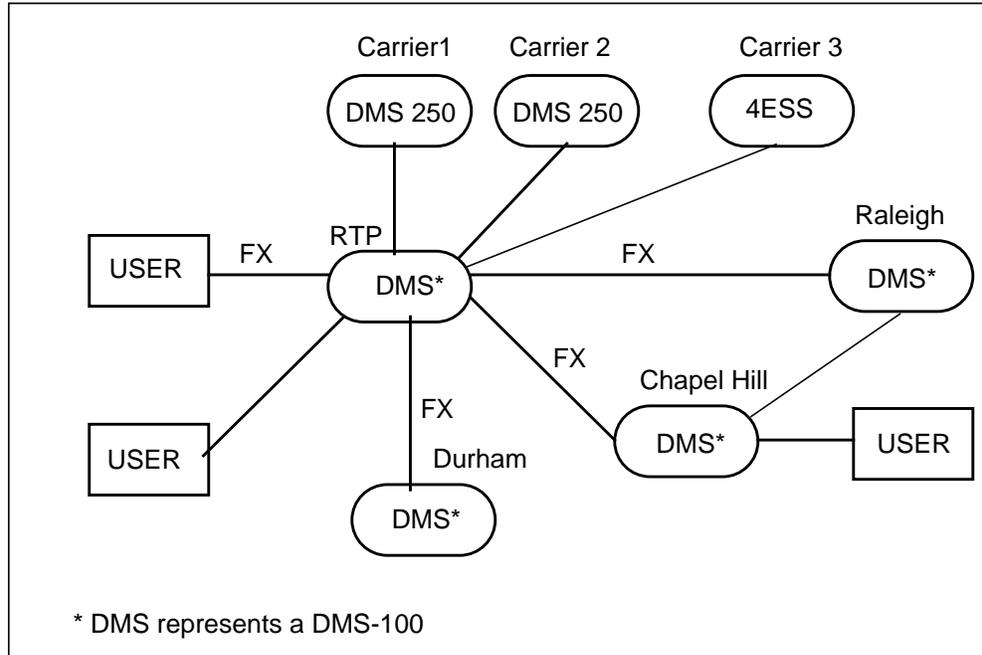

The network specific facilities (NSF) and the numbering plan indicator (NPI) transmit the call type. Table 6-10 shows the call-by-call and integrated service access availability by DMS call type.

**Table 6-10 Call by call and integrated service access**

DMS call type	NTNA (ISA)	NI (call by Call)
Private	Yes	No
Public	Yes	Yes
INWATS	Yes	Yes
OUTWATS	Yes	Yes
Tie	Yes	Yes
FX	Yes	Yes
Hotel/Motel	No	Yes
Selective Class of Call Screening	No	Yes

**Note:** Both NI-1 and NI-2 support the concept of identifying the call type and service separately from the channels available.

## Release Line trunk

The Release Line Trunk (RLT) feature is provided on NTNA PRI trunks for the DMS-100 and SL-100 (North American Loads only). The prime target for this feature is the Northern Telecom Meridian 1 PBX. Other devices are used with this feature if they follow the user-side RLT protocol described in PRI NIS A211-1, release 7.

**Note:** Throughout this document, the terms *DMS-100*, *SL-100* and *network side* are used synonymously. These terms refer to the equipment that is running the code that implements this feature. The terms *PBX* and *user side* refer to the equipment that implements the user side of RLT. Remember that even though the term *PBX* is used, any device capable of running the user side of RLT can be substituted.

RLT optimizes the usage of PRI trunks when it is in effect. Figure 6-16 shows a typical usage for RLT. Notice that many other scenarios are possible.

**Figure 6-16 Typical usage of RLT**

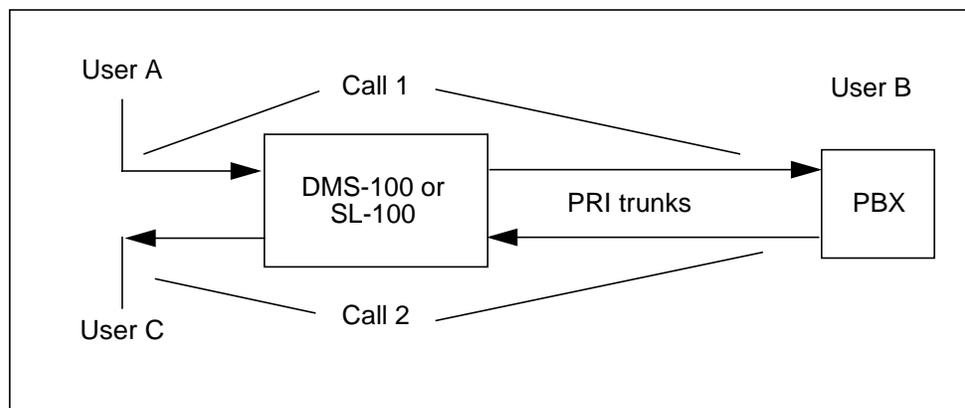

In the scenario in Figure 6-16, user A calls user B. This call is referred to as call 1. Call 1 is routed through the DMS-100 to the PBX. User B then forwards or transfers the call to user C, requesting RLT. This call (call 2) is routed through the same DMS-100. Notice that calls 1 and 2 can be on the same trunk or different trunk groups.

When the call (call 2) connects to user C, RLT is invoked. In this instance, the call is bridged at the DMS-100 and the PRI trunks to the PBX are released. Figure 6-17 shows the results of successfully invoking RLT.

**Figure 6-17 Results of invoking RLT**

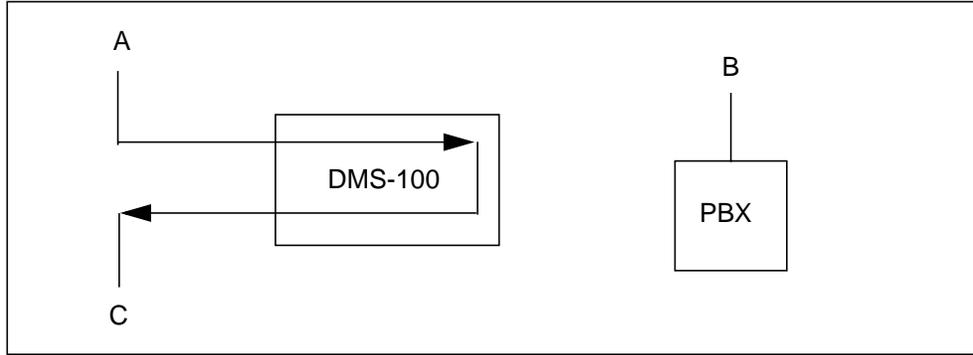

RLT is implemented for the DMS-100 and the SL-100 community using North American loads and PRI trunks (or PRI trunks datafilled as IBN). On the DMS-100, RLT is supported using both the event driven call processing (EDCP) model and the traditional call processing model. The SL-100 does not use the EDCP model of call processing but does use the traditional call processing model.

A PRI link is set up between two pieces of equipment. In Figure 6-16 and Figure 6-17, the two pieces of equipment are the DMS-100 on one side and a PBX on the other side. For the ISDN PRI protocol to work, one side must use the network-side protocol of PRI and the other side must use the user-side protocol. In the configuration in our figures, the DMS-100 uses the network-side protocol and the PBX uses the user-side protocol.

In the RLT protocol, the user side (the PBX) requests the RLT. The network side (the DMS-100) bridges the call and releases the PRI trunks. This feature implements the network side of RLT only and does not implement the user side RLT on either the DMS-100 or the SL-100. Although the SL-100 is a PBX, it supports network-side PRI links. Network-side links are used for RLTs in which the SL-100 is connected to a PBX or other RLT capable device. The user-side links on the SL-100 are not used for RLT.

This feature is available on an optional basis. This optionally takes two forms. The first form is through datafill on the individual trunk groups. If a trunk group is not datafilled for RLT, it cannot use RLT. The second form is password protection. In its delivered state, RLT is disabled on the entire switch, regardless of how the trunk groups are datafilled. By entering a password, the operating company personnel can enable RLT in the trunk groups for which it is datafilled. Subsequent to enabling RLT, the functionality is disabled on a switch-wide basis, again using the same password protection interface.



Figure 6-18 RLT overview

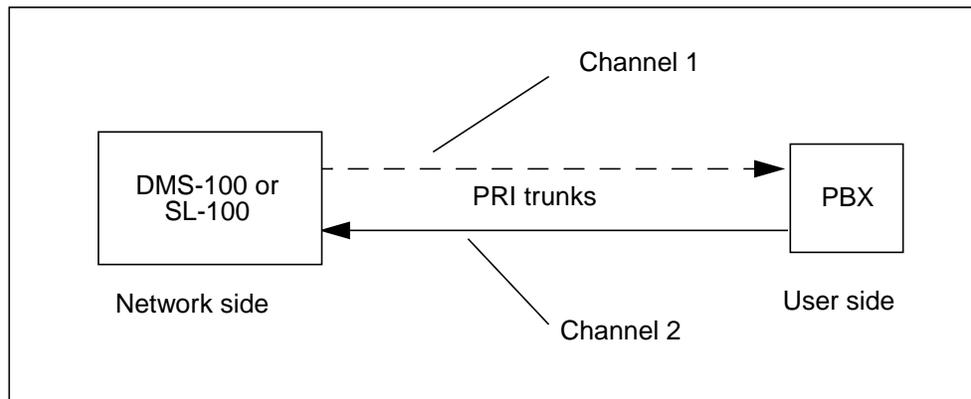

In all cases, RLT involves two B-channels that run between the network side (the DMS-100 or the SL-100) and the user side (the PBX) as shown in Figure 6-18. These B-channels can be on the same PRI trunk group or on different PRI trunk groups. If the B-channels are on different PRI trunk groups, they must connect to the same DMS-100 and PBX. One B-channel carries a call that originates from the network side and terminates on the user side. This B-channel is for a call incoming to the PBX. This channel is referred to as channel 1. The call carried over channel 1 is referred to as call 1.

The other B-channel carries a call that originates from the user side and terminates on the network side. This B-channel is for a call outgoing from the PBX. This channel is referred to as channel 2. The call that is carried over channel 2 is referred to as call 2.

To invoke RLT, the trunk groups, which can involve RLT traffic, must be datafilled for RLT. Any trunk groups that carry a call that is involved with RLT must be datafilled for RLT to succeed. Additionally, that RLT feature must be activated for the switch.

Figure 6-19, Figure 6-20, and Figure 6-21 detail messaging sequences, which describe the ways RLT is typically used. In these diagrams, the following conventions are used:

- A dashed line indicates a message is associated with call 1.
- A solid line indicates a message is associated with call 2.
- The bold-face messages have FACILITY Information Elements (IE) relating to RLT included in them.

There are many other ways to invoke RLT. The following three examples describe the common ways the Meridian 1 PBX uses RLT. Apart from the RLT specific messaging, which appears in bold face, the messaging sequence is the same as if RLT were not invoked. Also, notice that these scenarios are

dependent upon the PBX. These examples are given for illustrative purposes only. Different equipment can work differently.

Figure 6-19 shows the messaging sequence for RLT with Call Forward. In this example, user A calls user B. This call automatically forwards to user C. The telephone for user B does not ring. Instead, the telephone for user C rings, and the Q.931 signaling for the call propagates through the PBX to user A. When user C answers the telephone, the PBX invokes RLT and the call bridges at the DMS-100. The PRI lines to the PBX are taken down and user B is no longer involved with the call.

Figure 6-19 Messaging sequence for RLT with Call Forward

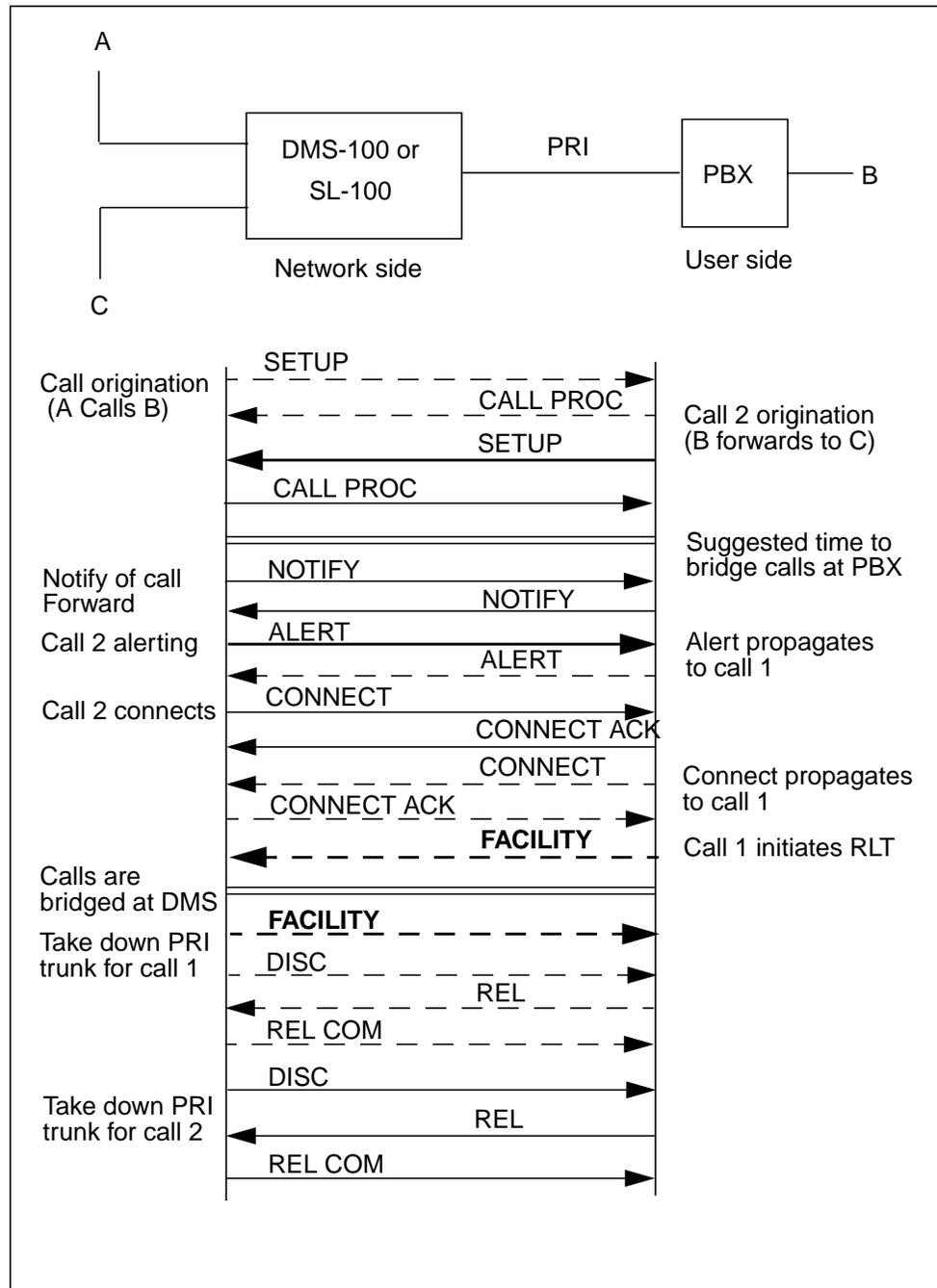

Figure 6-20 shows the messaging sequence for RLT with Call Forward, No Answer. This call type is similar to Call Forward, but has one main difference. When user A calls user B, the telephone rings for user B. After a certain period of time (provided that user B does not answer the telephone), the call forwards to user C. The PBX does not propagate the Q.931 ALERTING message to user

A, since it was already informed that the call was alerting. Apart from this, there is no difference between Call Forward, No Answer and Call Forward.

**Figure 6-20 Messaging sequence for RLT with Call Forward, No Answer**

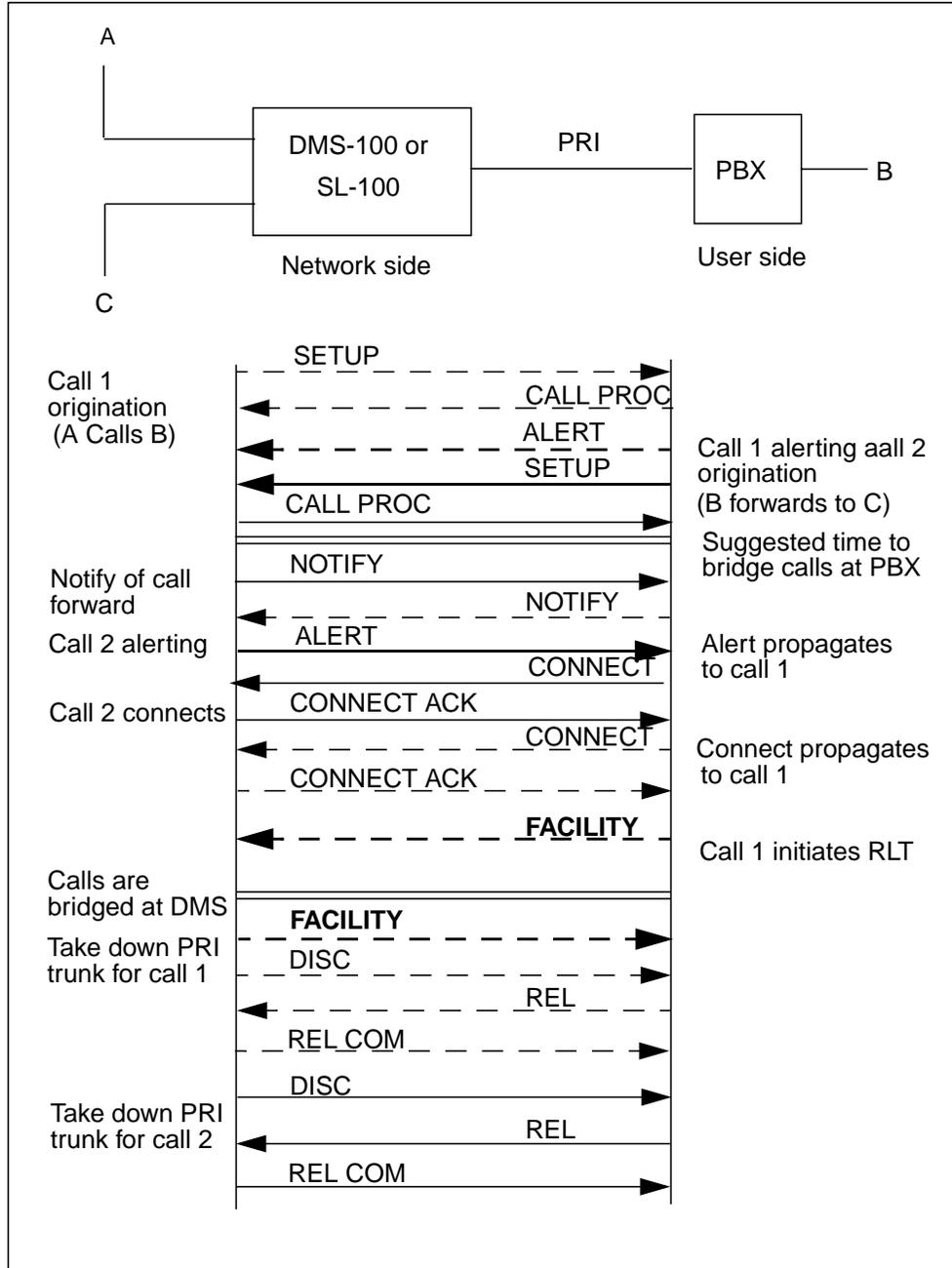
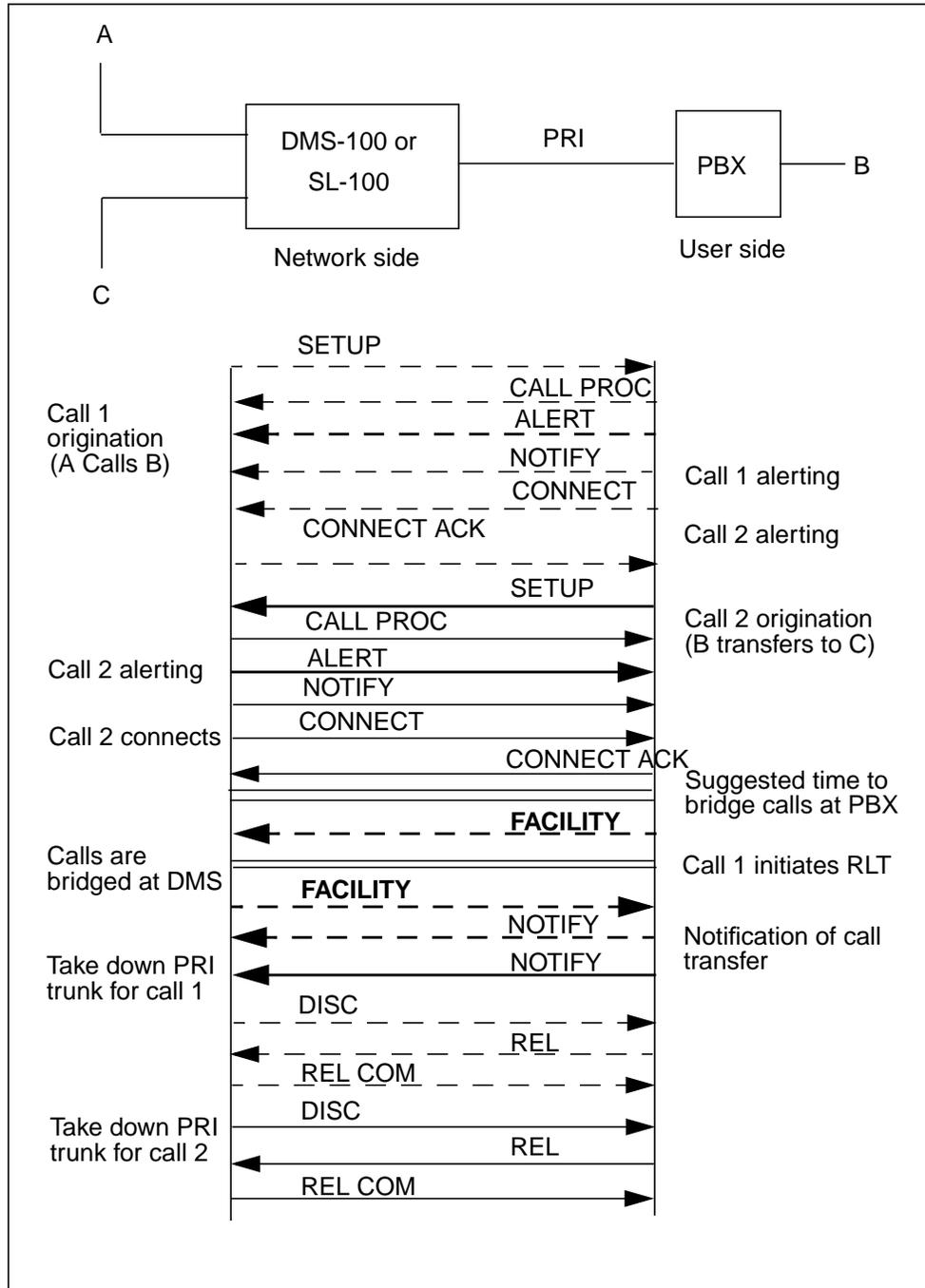

Figure 6-21 shows the messaging sequence for RLT with Call Transfer. In this example, user A calls user B. User B answers the telephone and then transfers the call to user C. Because user A and user B are already connected, the PBX

does not propagate Q.931 messages from user B to user A. Sometimes, after user C answers the telephone, user B drops out of the call and the PBX invokes RLT. The call is bridged at the DMS-100 and the PRI lines to the PBX are taken down. User B is no longer involved with the call.

**Figure 6-21 Messaging sequence for RLT with Call Transfer**



Despite the previous two examples, Notice that it does not matter if call 1 originates before or after call 2. It is possible for call 2 to be set up for RLT before call 1 arrives, if the PBX predicts a need for a future transfer.

When RLT is invoked, calls 1 and 2 must both be connected. Both calls must also be bridged at the PBX to ensure that user A receives the appropriate tones and announcements from call 2. In the previous examples, suggestions are made as to the appropriate time to bridge the calls at the PBX. In both Call Forward scenarios (Figure 6-19 and Figure 6-20), the call should bridge immediately after call 2 receives a CALL PROCEEDING message to allow user A to hear the tones and announcements for the call. In the Call Transfer scenario (Figure 6-21), bridging can wait until just before RLT is invoked to ensure that the call stays up even if RLT fails. Notice that no user can be associated with the call at the PBX when RLT is invoked. Otherwise, the users are disconnected from the call when RLT takes down the two PRI trunks.

There are two separate phases of messaging required to invoke RLT. The first phase occurs when call 2 originates. If the PBX wants to involve call 2 in RLT, it must include a FACILITY IE in the SETUP message when originating call 2.

When the network side receives a SETUP message with a FACILITY IE requesting RLT, it responds by adding its own FACILITY IE to the ALERTING or PROGRESS message associated with call 2. This FACILITY IE contains the call ID of call 2. The user side must remember the call ID that was sent because it is used to invoke RLT at a later time.

Any time after call 2 originates and before is RLT invoked, the user side must bridge calls 1 and 2. RLT must also disconnect any of the users at the user side who are involved in either call.

When the above criteria is met, and provided that call 2 is connected, the user side can invoke RLT. The user side can send a FACILITY message associated with call 1 to the network side. This FACILITY message must contain a FACILITY IE with the call ID that was previously sent back from the network side.

Upon receiving the FACILITY message, the network side bridges the two calls. It then sends DISCONNECT messages, associated with each call, to the user side. This user and network sides then proceed to release the two channels in the usual way. The end result of this action is that two calls are bridged at the network side. No B- or D-channels between the network side and the user side are involved in either call. The user side is not involved in either call at this point.

Call billing occur as if RLT was never invoked.

Error conditions can occur. However, error conditions do not interfere with call processing. RLT will be disallowed. Since the calls are already bridged at the PBX, the call stays up. In general, there are two places where an error condition can occur. The DMS-100 can disallow RLT after receiving the SETUP message. Alternately, the DMS-100 can fail to bridge the call after receiving the FACILITY message.

Typical scenarios for error handling are shown in Figure 6-22 and Figure 6-23. For convenience, both scenarios are based on a Call Forward scenario. Similar activity occurs for other scenarios. In Figure 6-22, the PBX requests to invoke call 2 in RLT. The DMS-100 determines that RLT is not allowed for the trunk group on which call 2 is situated. This situation can be because the trunk group was not datafilled for RLT, or because this feature is not enabled on the DMS-100. The PBX returns a FACILITY IE in the ALERTING message indicating that RLT is not allowed. The call continues as if RLT was never invoked.

Figure 6-22 RLT not allowed scenario

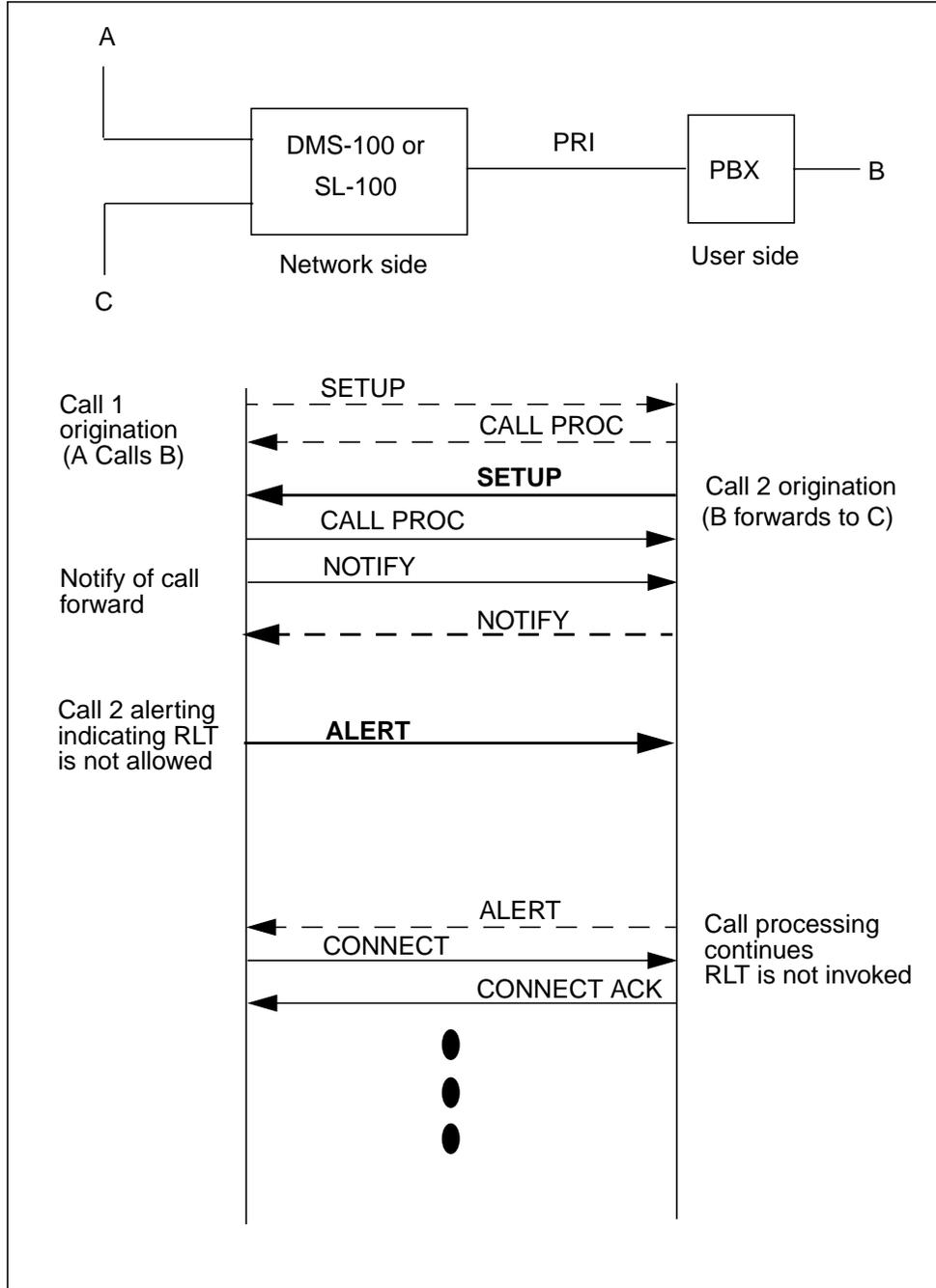
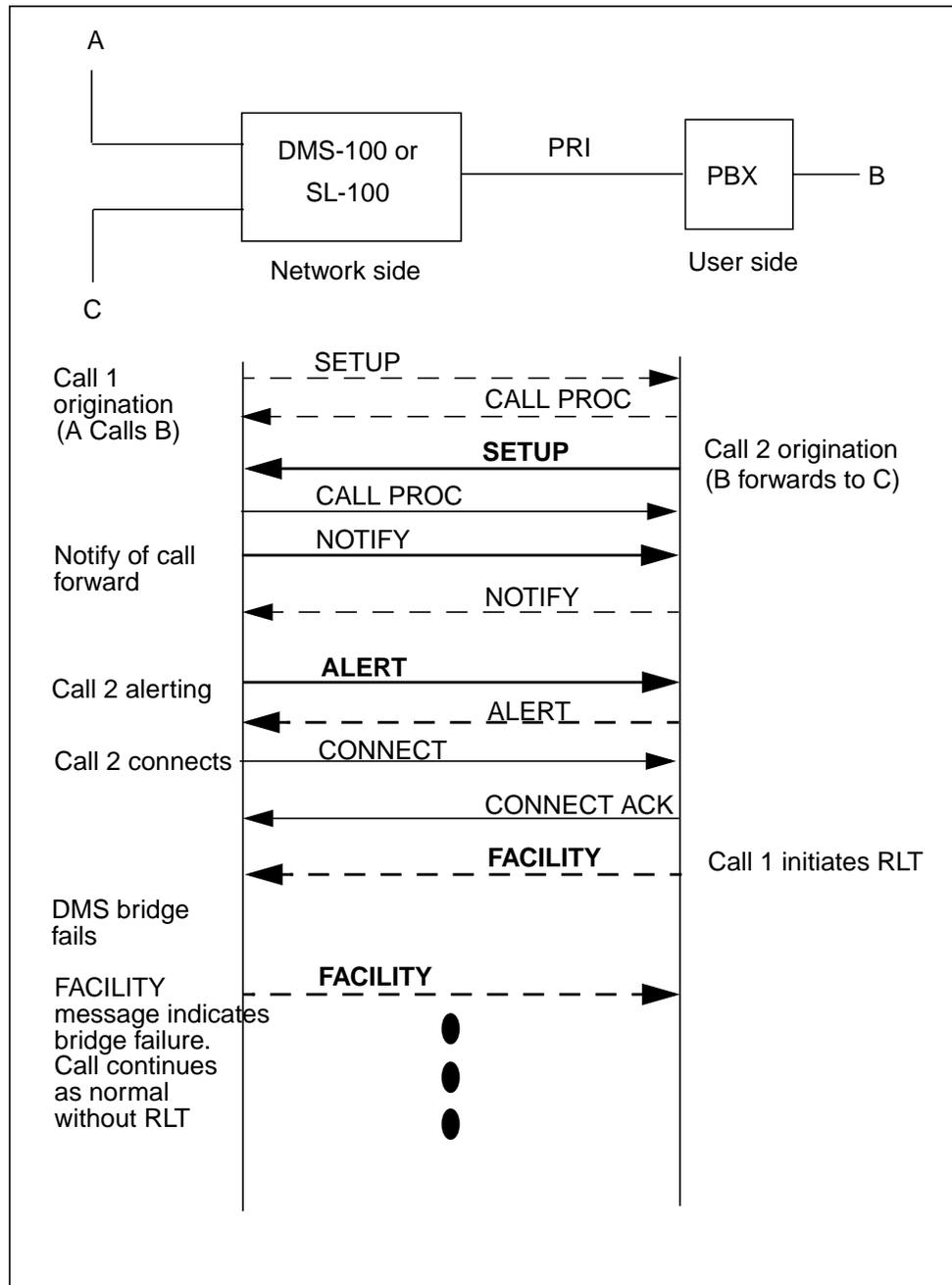

Figure 6-23 depicts a situation in which the call cannot bridge at the DMS-100. RLT is successfully set up for call 2, but when the PBX tries to invoke RLT, call bridging fails. This situation can occur for many reasons. The trunk group for call 1 may not be datafilled for RLT. RLT may be disabled on the DMS-100 between the time that call 2 was set up and the time that RLT was invoked.



There may simply not be enough resources available in the DMS-100 to bridge the calls. Whatever the reason, the DMS-100 returns a FACILITY IE in a FACILITY message indicating that bridging failed. The call continues as if RLT was never invoked.

**Figure 6-23 RLT scenario with Bridge Failure**



### Enabling the RLT Option

This feature allows RLT to be available to NTNA PRI trunks on a DMS-100 or a SL-100 when the RLT option is datafilled in table TRKGRP. The ability to datafill this option on a DMS-100 or SL-100 is implemented as part of this feature. Refer to Figure 6-24, which shows a typical entry in this table with the RLT option datafilled. This option is only datafilled on the network side of an NTNA trunk group.

**Figure 6-24 Sample RLT entry in TRKGRP table**

```
TABLE: TRKGRP

>pos 64K1DT0

64K1DT0
PRA 0 PRAC NCRT ASEQ N (ISDN 3) (MRLT) $
```

This feature must also be activated via the password protected software optional control interface. For convenience, the RLT option is datafilled before the feature is activated. In this case, the switch operates as if RLT the trunk groups were not datafilled for RLT. As soon as the feature is activated, RLT becomes available on all the trunk groups for which it is datafilled. This allows simple enabling and disabling of RLT on a switch bases, without having to remove the datafill from table TRKGRP. The specific trunk group must still be datafilled for RLT.

### Interactions

There are no feature interactions which cause bridging to fail.

If the PBX sends notify messages after it invoked RLT, these may not propagate to their intended recipients. The PBX must send all notify messages before invoking RLT. Notice that this is not presently the case with the Meridian 1 PBX.

RLT feature interactions with both AIN 0.1 and AIN 0.2 are not supported. However, RLT feature interactions with Local Number Portability (LNP) are supported.

### Restrictions and limitations

There are not feature interaction restrictions.

There are several limitations in the scope of this feature.

- The feature is only implemented for the North American market on NTNA PRI.
- The feature works with the Meridian 1 PBX. Other devices that implement RLT use the user-side RLT protocol described in the PRI NIS A211-1, release 7.
- Only the network side of RLT is implemented.
- the feature will not be generally available. It will be controlled by SOC control.
- Interactions with ISUP CCTO (or any other trunk optimizing scheme) is not supported. This feature will only optimize the PRI trunks between the DMS-100 and the PBX in question (which have to be directly connected).

## Service Identifier Routing

The service identifier (SID) is a way to further identify a preferred route. Any call type, except PUB, can use a SID. The PBX routes the call by sending a specific SID. The example shown is being used for a foreign exchange scenario, although it can be used with long distance to access carriers in our illustration. Figure 6-25 shows an example SID on an FX.

**Figure 6-25 Service Identifier Routing on an FX**

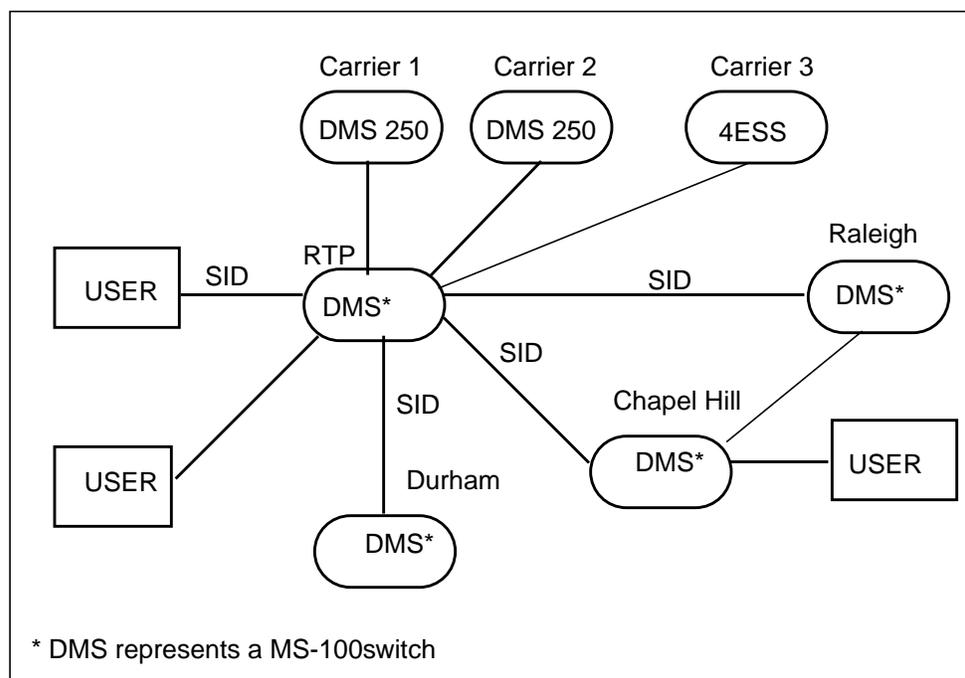

SID sends a call directly to a specific trunk with minimal call processing. This is especially useful with TIE and FX call types for which the subscriber knows the destination. SID routing allows subscribers to do their own routing.

With the SIDXLA option selected in table LTCALLS, the DMS switch takes the incoming SID and determines the route in table ISAXLA. The diagrams also show sizing through virtual facility groups. Figure 6-26 shows the table flow for Service Identifier Routing.

**Figure 6-26 Table flow for Service Identifier (SID) Routing**

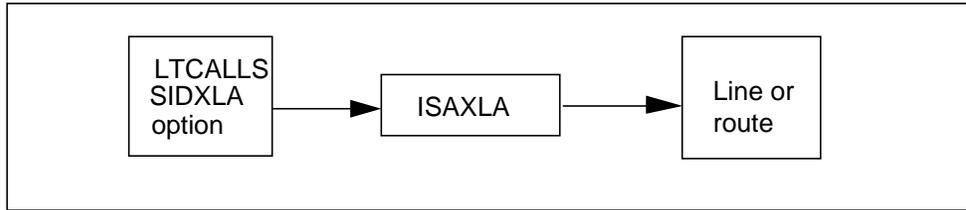

Figure 6-27 shows the table flow for routing with sizing.

**Figure 6-27 Table flow for (SID) routing with sizing**

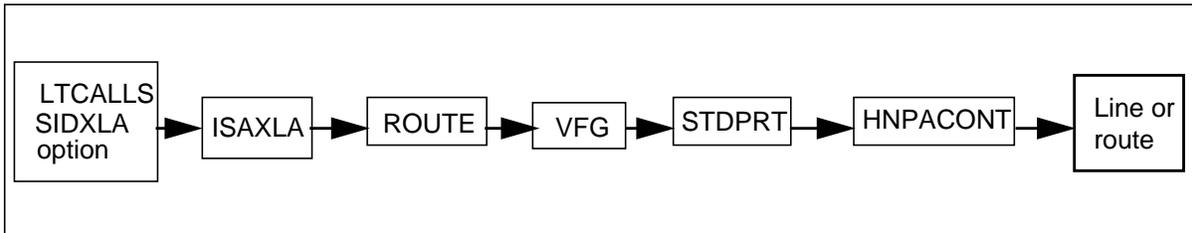
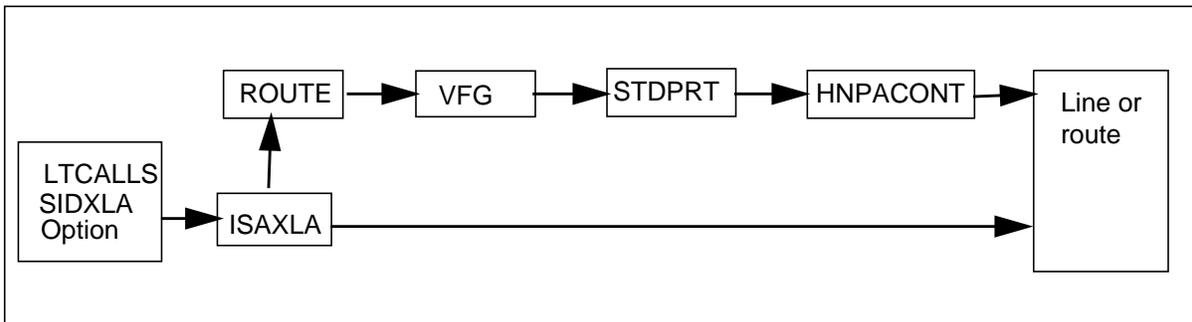

Figure 6-28 shows the table flow for routing with or without sizing.

**Figure 6-28 Table flow for (SID) routing with or without sizing**



**Table ISAXLA**

Table ISAXLA reviews the incoming SID and sends the call directly to a route. Figure 6-29 shows an example of table ISAXLA.

**Figure 6-29 Example of table ISAXLA**

IRTRNAME	SIDFROM	SIDTO	RTEID
PRIFX	0	0	(IBNRTE 7)\$
PRIFX	4	4	(IBNRTE 505)\$
PRIFX	5	5	(IBNRTE 1004)\$
PRIFX	6	6	(IBNRTE 1005)\$
PRIFX	7	7	(IBNRTE 1006)\$

Table 6-11 shows a description of the fields and settings in table ISAXLA.

**Table 6-11 Description of table ISAXLA (Sheet 1 of 2)**

Field	Subfield	Entry	Description
IRTRNAME		alphanumeric (up to 128 8-character names)	Router name. Enter the router name to be used in table LTCALLS under the XLAISA selector, or in field IRTRNAME in table MBGXLA.
SIDFROM		0-1 023	Service identifier from. Enter the lower boundary of the service identifiers (SID) values that continue translations and routing.
SIDTO		0-1 023	Service identifier to. Enter the upper boundary of the service identifiers (SID) values that continue translations and routing.
RTEID		Route identifier- This field consists of subfield.	TABNAME - IBNRTE (Enter IBNRTE or OFRT to indicate the table name to which translations will route.)

**Table 6-11 Description of table ISAXLA (Sheet 2 of 2)**

Field	Subfield	Entry	Description
	TABNAME	IBNRRT2, IBNRRT3, IBNRRT4, IBNRTE, OFR2, OFR3, OFR4, OFRT, ITOPS	Table name> Enter the routing table name. If no route identifier is used, enter \$.
INDEX		0-1 023	Index. Enter the index into the routing table. Enter the index into the routing table. If the entry in subfield TABNAME is TOPS, enter the call origination index in table TOPS.

**SID route TRAVER example**

If table LTCALLS is datafilled with option SIDXLA, every call that arrives at the DMS switch with the specified call type avoids normal translations. The call is sent directly to a specified trunk. The DMS switch can only access normal translations when no SID or invalid SID is present. If a subscriber does not send a SID, Treat\_No\_SID defines what action is taken. If Y is selected, the call is sent to treatment. If N is selected, the translation continues using information from the NPI, NSF, XLARTE, and called digits. In some cases, a default SID that is not intended for SID routing, typically SID = 0, is transmitted. Nortel recommends that SID = 0 route to normal translations.

In the following TRAVER example, IBNRTE 7 directs the call to normal translations.

```
>traver tr pri14 n cdn e164 2222104 fx 4 b rtevfg all
TABLE TRKGRP
PRI14 PRA 0 NPDGP NCRT ASEQ N (ISDN 150) $ $
TABLE LTCALLS
ISDN 150 FX XLAIBN 300 PBXGROUP 0 0 (SIDXLA PRIFX Y Y N) $
TABLE CUSTSTN
TUPLE NOT FOUND
TABLE OFCVAR
AIN_OFFICE_TRIGGRP NIL
TABLE ISAXLA
PRIFX 4 4 (IBNRTE 505) $
TABLE IBNRTE
505 ISA N N N SPRINTPRI PUB NONE N N 0
. TABLE TRKGRP
. SPRINTPRI IBNT2 0 NPDGP NCRT ISDN2 0 MIDL 0 N ANSDISC 0 Y N
```

```

N N N Y N 0 0 N 0
.      0 0 N N N N N N N N NATL (CALLCHR DIGDATA) (LTID ISDN
1018)
.      (BCNAME 3_1KHZ) (SMDRITC ) $
. TABLE LTCALLS
. ISDN 1018 PUB XLALEC 10 $
EXIT TABLE IBNRTE
+++ TRAVER: SUCCESSFUL CALL TRACE +++
DIGIT TRANSLATION ROUTES

1 SPRINTPRI                      N CDN  E164  L  2222104 NIL_NSF
BC SPEECH

TREATMENT ROUTES.  TREATMENT IS: GNCT
1 120TONE

```

### SID route TRAVER example with sizing

In this TRAVER example, the call is routed through table VIRTGRPS for trunk group sizing.

```

>traver tr pri14 n cdn e164 5512104 fx 5 b rtevfg all
TABLE TRKGRP
PRI14 PRA 0 NPDGP NCRT ASEQ N (ISDN 150) $ $
TABLE LTCALLS
ISDN 150 FX XLAIBN 300 PBXGROUP 0 0 (SIDXLA PRIFX Y Y N) $
TABLE CUSTSTN
TUPLE NOT FOUND
TABLE OFCVAR
AIN_OFFICE_TRIGGRP NIL

TABLE ISAXLA
PRIFX 5 5 (IBNRTE 1004) $
TABLE IBNRTE
1004 VFG N N N ERIC 0
EXIT TABLE IBNRTE
+++ TRAVER: SUCCESSFUL CALL TRACE +++
DIGIT TRANSLATION ROUTES
1 VFG: ERIC                      5512104                      ST
TREATMENT ROUTES.  TREATMENT IS: GNCT
1 120TONE
+++ TRAVER: SUCCESSFUL CALL TRACE +++
---->
----> Resolving VFG: ERIC Route with calling digits 5512104
---->
TABLE VIRTGRPS
ERIC SIZE 1 POTS 9022225804 300 Y $
TABLE LINEATTR
300 PBX NONE NT NSCR 0 902 PBX NLCA NONE 0 NIL NILSFC NILLATA 0
NIL NIL 00 N $
LCABILL OFF - BILLING DONE ON BASIS OF CALLTYPE
TABLE STDPRTCT
PBX ( 1 ) ( 0 ) 0
. SUBTABLE STDPRT
WARNING: CHANGES IN TABLE STDPRT MAY ALTER OFFICE
BILLING.  CALL TYPE DEFAULT IS NP.  PLEASE REFER TO
DOCUMENTATION.
. 551 551 T DD 0 IBNRTE 505 3 15 NONE
AIN Info Collected TDP: no subscribed trigger.
AIN Info Analyzed TDP: no subscribed trigger.

```

```

. . TABLE IBNRTE
. . 505 ISA N N N SPRINTPRI PUB NONE N N 0
. . . TABLE TRKGRP
. . . SPRINTPRI IBNT2 0 NPDGP NCRT ISDN2 0 MIDL 0 N ANSDISC
0 Y N N N N Y N
. . . 0 0 N N N N N N N N NATL (CALLCHR DIGDATA) (LTID
ISDN 1018)
. . . (BCNAME 3_1KHZ) (SMDRITC ) $
. . . TABLE LTCALLS
. . . ISDN 1018 PUB XLALEC 10 $
. . EXIT TABLE IBNRTE
. SUBTABLE AMAPRT
. KEY NOT FOUND
. DEFAULT VALUE IS: NONE OVRNONE N
LATA IS NIL, THEREFORE NOT AN EQUAL ACCESS CALL
+++ TRAVER: SUCCESSFUL CALL TRACE +++
DIGIT TRANSLATION ROUTES

1 SPRINTPRI N CDN E164 L 5512104 NIL_NSF
BC SPEECH
TREATMENT ROUTES. TREATMENT IS: GNCT
1 120TONE

```

### Translations for specific PRI features and services

The following section describes translations for the following PRI features and services. The features are listed in alphabetical order except for PRI Base Service which is listed first.

- PRI Base Service
- ISP Even Call Distribution
- PRI Backup D-channel
- PRI Bearer Capability Routing
- PRI Call Routing
- PRI Call Screening
- PRI Calling Line Identification Blocking
- PRI Calling Name Delivery
- PRI Equal Access
- PRI Flexible Timers
- PRI Hotel/Motel and Selective Class of Call Screening for NIPRI
- PRI ISDN Treatments
- PRI Message Waiting Indicator
- PRI Network Ring Again
- PRI SUSP for PRI CNAME
- PRI Two B-channel Transfer



---

## Call Forward/Interface Busy

---

### Ordering codes

Functional group ordering code: NI000047

Functionality ordering code: not applicable.

### Release applicability

NA013 and up

NA013 introduced Call Forward/Interface Busy.

### Requirements

The Call Forward/Interface Busy feature has no functional group requirements.

### Description

The Call Forward/Interface Busy (CFIB) feature provides the capability to forward calls to a remote directory number (DN) when the routelist to the base DN is busy. The term interface in this feature refers to the routelist entry in the routing tables. A routelist is considered busy when all routes in the routelist are call processing busy, out-of-service, or unavailable. In such situations, if the base DN subscribes to the CFIB feature, the call is redirected to a new DN, also known as the remote DN.

The targeted customers for CFIB are the internet service providers (ISP). One application of this feature is to forward the calls from a location in one time zone, whenever the routelist is busy, to another location in a different time zone where there may be less traffic. Another application of this feature is to provide a way to handle routing during disaster situations that cause the routelist to be unavailable.

The basis for CFIB subscription is by individual DN. All DNs that subscribe to CFIB are referred to as base DNs in this document. The DNs to which the calls are forwarded are referred to as remote DNs. The originating DN is the DN of the user that calls the base DN.

Two configurations of originating DN, base DN, and remote DN are depicted in the following figures. The first figure shows the originating DN and base DN located on the same stored program controlled system (SPCS) while the remote DN is on a remote SPCS.

## Call Forward/Interface Busy (continued)

---

### Operation

When a call to a base DN fails due to the routelist being call processing busy, out-of-service, or unavailable and if the base DN subscribes to CFIB, then the switch forwards the call to a remote DN based on the bearer capability of the incoming call. The switch forwards the call to the remote DNs provided the following conditions are met:

- the call is a circuit-mode call
- this feature supports the bearer capability of the call
- the maximum redirection count is not reached

The redirection data, which consists of the original called number (OCN), the redirecting number (RGN), and the redirecting reason (RGR), are sent to the originator and the terminator.

### Translations table flow

The list that follows includes the Call Forward/Interface Busy feature translations tables:

- DNROUTE
- CFIBDATA

The flowchart that follows provides the Call Forward/Interface Busy feature translations process.

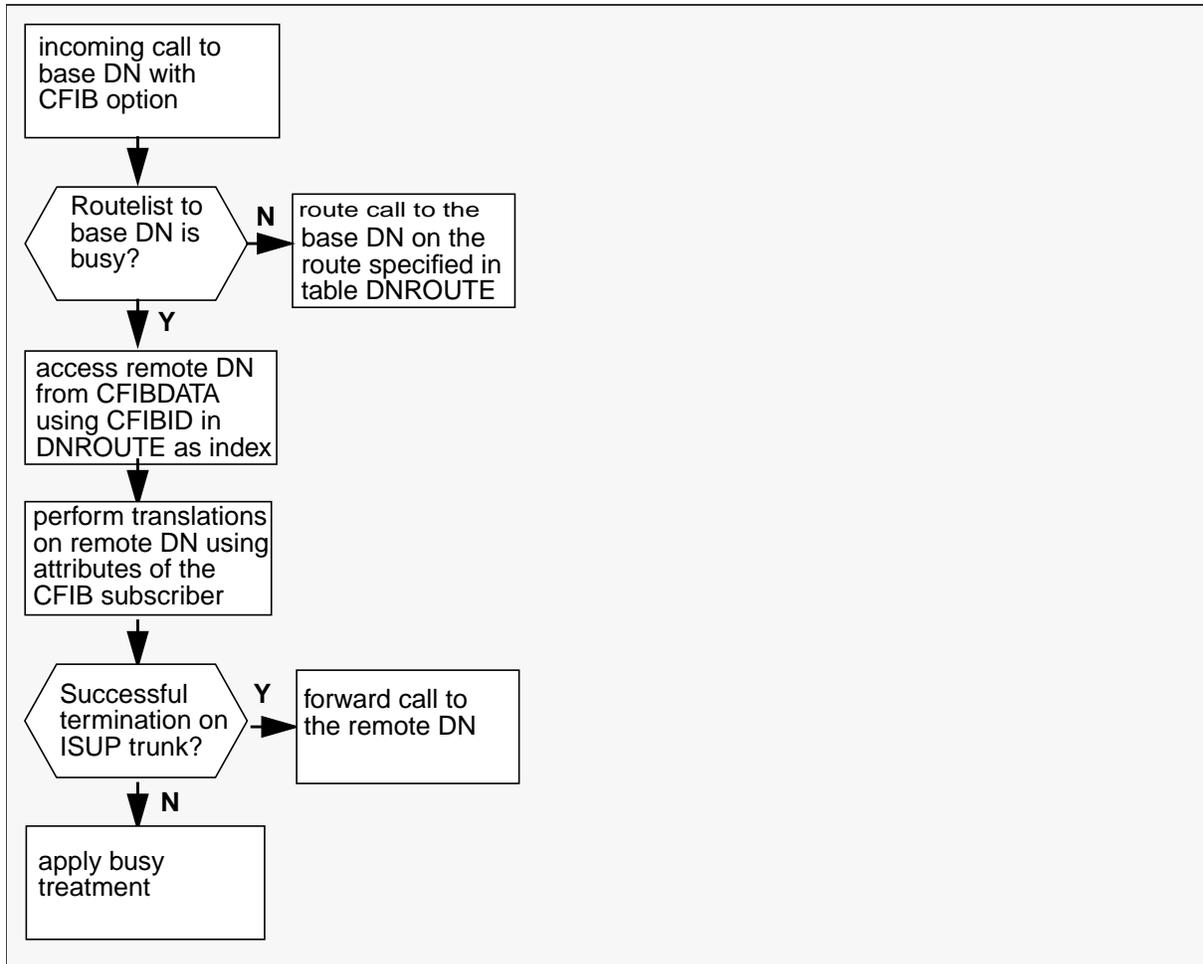
**Call Forward/Interface Busy** (continued)**Table flow for Call Forward/Interface Busy**

---

## Call Forward/Interface Busy (continued)

---

The table that follows lists the datafill content used in the flowchart.

### Datafill example for Call Forward/Interface Busy

Datafill table	Example data
DNROUTE	613 722 8880 FEAT CFIB IBNRTE 20 CFIB1 ISDN 1012 6135551010 Y
CFIBDATA	CFIB1 5551000 5551007 7915551111 8015551003

### Limitations and restrictions

The limitations and restrictions that follow apply to the Call Forward/Interface Busy feature.

- The base DN and the remote DN must be assigned on different switches. Therefore, CFIB can only be activated once for each call in the base SPCS.
- The remote DN must not subscribe to CFIB. The software does not enforce this restriction.
- Only the following types of originators support the CFIB feature:
  - PRI trunks
  - ISUP trunks
  - IBN MF trunks
  - BRI lines
  - POTS lines
  - RES lines
  - IBN lines
- The routelists that are still being referenced by the CFIB feature DNs in the DNROUTE table should not be deleted from the routing tables. This restriction is not enforced by software.
- This feature does not support the Routing table IRTE (for DMS-250).
- The provisioned remote DNs are not validated. It is the responsibility of the operating company personnel to ensure that the remote DNs provided are valid.
- The provisioning of all remote DNs is mandatory.
- This feature provides no software restriction to prevent other trunks besides National ISDN (NI2) and NTNA PRI trunks from being provisioned in the routelist to the base DN, However, testing is performed with NI2 and NTNA PRI trunks only.

---

## Call Forward/Interface Busy (continued)

---

- The calls forwarded as a result of CFIB must be terminated on ISUP trunks only.
- The provisioned billing DN in table DNROUTE must be a 10-digit number.
- A maximum of 255 tuples can be provisioned in table CFIBDATA.
- A maximum of 10,000 DNs are allowed to have CFIB provisioned in the DNROUTE table.
- Routing table RRTE is not supported.
- The capability of displaying information on the origination and termination display sets is not supported.
- Packet mode calls are not supported for CFIB.

### Interactions

The paragraphs that follow describe how Call Forward/Interface Busy interacts with other functionalities.

When Call Forward (CFW-all kinds), advanced intelligent network (AIN) redirections, key short hunt (KSH) or line overflow to DN (LOD) occurs before CFIB, the original called number (OCN) and the original redirecting reason (ORR) are provided by these redirection features. Redirecting number (RGN) and redirecting reason (RGR) are provided by the CFIB. In these cases, the RGN is the base DN provisioned with CFIB. The RGR is user busy.

Only AIN redirections are allowed to occur after CFIB. In this case, CFIB provides the OCN (the base DN) and ORR (user busy). AIN redirections provide the RGN and RGR.

If the routelist uses Super Trunk Group (SG selector) to the base DN, CFIB will be attempted after the maximum number of attempts (attempts for SG selector in routing tables) has been reached for the Super Trunk Group.

If the switch uses a virtual facility group (VFG) to route calls to a base DN. The size limitation in VIRTGRPS is the total number of calls present on the base DN route plus the number of active CFIB calls.

### Activation and deactivation by the user

The Call Forward/Interface Busy feature does not require activation or deactivation by the user.

## Call Forward/Interface Busy (continued)

---

### Billing

The Call Forward/Interface Busy feature generates two automatic message accounting (AMA) records. The feature generates one AMA record for the originating DN to the base DN portion of the call. The feature generates a second AMA record for the base DN to the remote DN portion of the call. The second AMA record uses a special billing DN, which the DNROUTE table provisions. The CFIB feature appends the ISDN core module (Module 70/71) to the AMA record of the base DN to the remote DN portion of the call.

### Station Message Detail Recording

The Call Forward/Interface Busy feature does not require Station Message Detail Recording.

### Office parameters used by Call Forward/Interface Busy

The Call Forward/Interface Busy feature does not generate office parameters.

### Datafill sequence

The table that follows lists the tables that require datafill to put Call Forward/Interface Busy into operation. You must enter data into the table in this order.

#### Datafill requirements for Call Forward/Interface Busy

Table	Purpose of table
DNROUTE	Directory Number Route contains information for programmable DNs, for example, it specifies the route and CFIB feature associated with a base DN.
CFIBDATA	Call Forward Interface Busy Data contains information about the DNs to which the call is to be forwarded.

---

## Call Forward/Interface Busy (continued)

---

### Datafill related to Call Forward/Interface Busy for table DNROUTE

The table that follows provides the datafill related to the Call Forward/Interface Busy feature for the DNROUTE table. This table includes only those fields that apply directly to the Call Forward/Interface Busy feature.

#### Datafill related to table DNROUTE

Field	Subfield	Entry	Explanation and action
FEAT		CFIB	Feature. Enter CFIB for the Call Forward/Interface Busy feature
TABNAME		OFRT, OFR2, OFR3, OFR4, IBNRTE, IBNRT2, IBNRT3, IBNRT4	Table name. Specify the routelist that is to be used to route the incoming call to the base DN.
INDEX		1–1023	Enter the index into the routing table.
CFIBID		A string of up to 16 characters	Index of table CFIBDATA used to get information about remote DNs.
CFIBBASE		common language location identifier (CLLI)	This PRI CLLI becomes the originator of the forwarded call to the remote DN, when all routes in the routelist are busy.
CFIBSBDN		A 10-digit number	Billing number to be used for the base DN to remote DN portion of the CFIB call
RPNPP		Y or N	Indicate whether the presentation of the remote party number (remote DN) is allowed. The default is Y.

#### Datafill example for table DNROUTE

The figure that follows shows sample datafill for the DNROUTE table.

## Call Forward/Interface Busy (continued)

### MAP example for table DNROUTE

FEATURE	TABNAME	INDEX	CFIBID	CFIBBASE	CFIBSBDN	RPNPP
CFIB	IBNRTE	20	CFIB1	CLLI1	6135551010	Y

### Error messages for table DNROUTE

The error messages that follow apply to the DNROUTE table.

#### Error messages for table DNROUTE

Error message	Explanation and action
THE NUMBER OF CFIB TUPLES CANNOT EXCEED 10,000.	The switch generates this message when the maximum number (10 000) of DNs provisioned with CFIB has been reached.
THE ENTERED CFIBID MUST BE PROVISIONED IN CFIBDATA	The switch generates this message while attempting to add a CFIB tuple in DNROUTE which has a CFIBID that is not provisioned in table CFIBDATA.
THE ENTERED ROUTE IS INVALID. THE ROUTE IS NOT PROVISIONED IN TABLE <specified table>.	The switch generates this message while attempting to add a CFIB tuple in DNROUTE that has an invalid route table index.
IRTE IS NOT SUPPORTED FOR CFIB	The switch generates this message while attempting to add a CFIB tuple in DNROUTE with IRTE as the routing table.
RRTE IS NOT SUPPORTED FOR CFIB.	The switch generates this message while attempting to add a CFIB tuple to table DNROUTE with RRTE as the routing table.
CANNOT FIND CFIBID IN CFIBDATA – DATA CORRUPTED	The switch generates this message while attempting to position on a CFIB tuple in DNROUTE that has a CFIBID that is out of range. The table CFIBDATA may be corrupt.



---

## Call Forward/Interface Busy (continued)

---

### Datafill related to Call Forward/Interface Busy for table CFIBDATA

The table that follows provides the datafill related to the Call Forward/Interface Busy feature for the CFIBDATA table. This table includes only those fields that apply directly to the Call Forward/Interface Busy feature.

#### Datafill related to table CFIBDATA

Field	Subfield	Entry	Explanation and action
CFIBID		A string of up to 16 characters	CFIB identifier. This is the key to a tuple in table CFIBDATA. This identifier is specified in table DNROUTE for a DN subscribing to the CFIB option.
RDNSPCH		DN (maximum 15 digits)	DN to which the call is forwarded if the incoming bearer capability is Circuit-Mode Speech.
RDN3KAUD		DN (maximum 15 digits)	DN to which the call is forwarded if the incoming bearer capability is Circuit-Mode 3.1 KHz Audio.
RDN64KUD		DN (maximum 15 digits)	DN to which the call is forwarded if the incoming bearer capability is Circuit-Mode Unrestricted Digital Information (64 kbit/s)
RDNUDAD		DN (maximum 15 digits)	DN to which the call is forwarded if the incoming bearer capability is Circuit-Mode Unrestricted Digital Information adapted from 56 kbit/s to 64 kbit/s.

#### Datafill example for table CFIBDATA

The figure that follows shows sample datafill for the CFIBDATA table.

#### MAP example for table CFIBDATA

CFIBID	RDNSPCH	RDN3KAUD	RDN64KUD	RDNUDAD
CFIB1	5551000	5551007	7915551111	8015551003

## Call Forward/Interface Busy (continued)

### Error messages for table CFIBDATA

The error messages that follow apply to table CFIBDATA.

#### Error messages for table CFIBDATA

Error message	Explanation and action
TABLE CFIBDATA IS FULL. The maximum number of tuples that can be added is 255.	The switch generates this message when the maximum number (255) of CFIB tuples has been reached while attempting to add a tuple.
CANNOT FIND TUPLE-DATA CORRUPTED	The switch generates this message while attempting to position on a tuple in CFIBDATA which is out of range. The data may be corrupt.

### Translation verification tools

The Call Forward/Interface Busy feature does not use translation verification tools.

### SERVORD

The Call Forward/Interface Busy feature uses the Service Order System (SERVORD).

#### SERVORD limitations and restrictions

The Call Forward/Interface Busy feature has no SERVORD limitations or restrictions.

#### SERVORD prompts

The table that follows provides the SERVORD prompts used to add Call Forward/Interface Busy to a DN or block of DNs.

#### SERVORD prompts for Call Forward/Interface Busy (Sheet 1 of 3)

Prompt	Correct input	Explanation
SNPA	Valid SNPA provisioned in table TOFCNAME	Serving numbering plan area. Enter the area code for the DN.
BLOCK_OF_DNS	Yes or No	Block of directory numbers. Enter Yes if CFIB option is to be provisioned for a range of DNs.

---

**Call Forward/Interface Busy** (continued)

---

**SERVORD prompts for Call Forward/Interface Busy (Sheet 2 of 3)**

Prompt	Correct input	Explanation
DN	Valid DN	Directory number. The switch displays this prompt if the response to the BLOCK_OF_DNS is NO. Enter a valid DN to which CFIB is to be provisioned.
FROM_DN	Valid DN	From directory number. The switch displays this prompt if the response to the BLOCK_OF_DNS is Yes. Enter the first DN in the range of DNs.
TO_DN	Last 3 digits in the range of DNs.	To directory number, The switch displays this prompt if the response to the BLOCK_OF_DNS is Yes and follows the FROM_DN prompt.
VDNTYPE	CFIB	Virtual directory number type. Enter CFIB for the Call Forward/Interface Busy feature.
TABNAME	OFRT, OFR2, OFR3, OFR4. IBNRTE, IBNRT2, IBNRT3, IBNRT4	Table name routelist. Enter the routing table that contains the routelist to the base DN.
INDEX	0–1023	Route index. Enter the route index of the table entered in response to the TABNAME prompt.
CFIBID	Valid index in table CFIBDATA	CFIB identifier. Enter the index into table CFIBDATA.

## Call Forward/Interface Busy (continued)

### SERVORD prompts for Call Forward/Interface Busy (Sheet 3 of 3)

Prompt	Correct input	Explanation
CFIBSBDN	10-digit DN	CFIB special billing directory number. Enter the special billing DN used to bill the base DN to remote DN portion of the CFIB call.
RPNPP	Y or N	Remote party number presentation parameter. Enter Y or N to indicate whether the presentation of the remote party number (remote DN) is allowed.

### SERVORD example to add Call Forward/Interface Busy

The SERVORD example that follows shows how to add the Call Forward/Interface Busy feature to a block of DNs with the SERVORD NEWDN command in prompt mode.

### SERVORD example for Call Forward/Interface Busy in prompt mode

```

>NEWDN
SONUMBER:  NOW 99 6 18 PM
>
SNPA:
> 613
BLOCK_OF_DNS:
> YES
FROM_DN:
>7222000
TO_DN:
> 300
VDNTYPE:
> CFIB
CFIBSBDN:
> 6137221010
TABNAME:
> IBNRTE
INDEX:
> 20
CFIBID:
> CFIB1
RPNPP:
>Y
OPTION:
> $

```

---

**Call Forward/Interface Busy (end)**

---

The SERVORD example that follows shows how to add Call Forward/Interface Busy to a block of DN's with the SERVORD NEWDN command in no-prompt mode.

**SERVORD example for Call Forward/Interface Busy in no-prompt mode**

```
NEWDN $ 613 YES 7222000 300 CFIB 6137221010 IBNRTE 20 CFIB1  
Y $
```

## E911 Preferred DN

---

### Ordering codes

Functional group ordering code: NI000043

Functionality ordering code: NI000038

### Release applicability

NA012 and up

NA012 introduced E911 Preferred DN.

### Requirements

E911 Preferred DN has no functional group requirements.

This document includes all the data table information for this functionality. Complete use of this functionality can require software or hardware not described in this document.

### Description

Primary Branch Exchange (PBX) users do their own moves and changes of directory numbers (DN). The DN in the Public Safety Answering Point (PSAP) location may not be up-to-date or stored. The E911 Preferred DN feature ensures the PSAP receives the right DN from a National Integrated Services Digital Network (ISDN) Primary Rate Interface (PRI) trunk.

The E911 Preferred DN feature provides a default DN as the preferred DN or the user provided Calling Party Number (CPN) for 911 calls to the PSAP (if the CPN passes screening). The default DN option allows emergency personnel to arrive at a location near the emergency. The emergency personnel contact directs the emergency personnel to the correct emergency location.

If the PSAP database stores the accurate CPN location, then the PSAP receives the CPN. The accurate CPN allows emergency personnel to go to the emergency location.

**Note:** Some CPNs are private numbers and the PSAP database can not connect some of the private numbers to an address. The CPN must pass screening in order for the PSAP to receive the CPN. If screening fails, the PSAP receives the default DN.

The E911 Preferred DN feature only applies to 911, 0911, or 1911 calls. The E911 Preferred DN feature does not apply to other incoming x911 emergency calls.

---

## E911 Preferred DN (continued)

---

### Operation

The E911 Preferred DN feature provides a subscription parameter E911DN. The operating company can assign E911DN to each NI-PRI interface. The value of subscription parameter E911DN is calling number (CGN) or default. For incoming 911 calls only, CGN indicates to the switch to send the screened Calling Party Number (CPN) digits to the 911 operator. The default value indicates to the switch to send default DN as the CPN.

The operating company must datafill a default DN for the NI-PRI interface before using the E911 Preferred DN feature. The E911 Preferred DN feature adds option E911DN to field DN selector. The operating company datafills the 10-digit default DN in table LTDATA using the DN selector. This number represents the centralized location to direct emergency services.

The E911DN option only affects calls whose CPN is 911, 0911, or 1911. If the E911DN option is the CGN and the incoming CPN is not available, then the switch sends the default DN as the CPN. The switch sets the screening indicator (SI) for the CPN to network provided

The E911 Preferred DN feature uses the Call Screening feature to screen the CPN. The Call Screening feature analyzes the incoming CPN digits to make sure the call comes in on a valid ISDN interface. The location and emergency services information is more accurate when the switch validates or screens the CPN.

The E911 Preferred DN feature screens the CPN of a 911 call when the operating company does not datafill the calling line identifier (CLI) selector for the ISDN interface. If the operating company does not datafill the CLI selector and does datafill option E911DN, then the switch screens all 911 calls. The switch does not screen non-911 calls. The E911 Preferred DN feature must have a screening list for 911 calls. The screening list can be the same list as the one used for non-911 calls.

**Note:** If the operating company does not datafill CLI selector then the switch can not edit the CPN. The editing option is part of the CLI selector. If the operating company datafills the CLI selector, then the switch can edit 911 calls. Also, the switch screens and edits all non-911 calls.

If call screening passes then the switch sends the validated CPN. The switch sets the SI to user provided passed screening. If call screening fails then the switch sends the default DN as the CPN. The connected SI says network provided. This makes sure the 911 operator receives a validated DN.

## E911 Preferred DN (continued)

---

If option E911DN is the default, then the switch provides the default DN as the CPN. The switch sets the SI to network provided.

The ISDN PRI trunk can route the 911 call out of the switch to another trunk. Other trunks can transmit a CPN or a billing number. The E911 Preferred DN feature replaces the billing number with the DN that the switch transmits as the CPN. The switch sends the same DN when the outgoing trunks transmits the CPN or billing number. The switch does not do the normal billing number determination for the 911 calls.

If there is one change in direction then the switch processes the redirection number (RN1) and not the CPN. The switch sets the SI for the CPN to user provided not screened.

If option E911DN value is default then the switch sends the default DN as RN1. If option E911DN value is CGN then the switch screens RN1, because the operating company does not datafill RN screening. If RN1 passes screening the switch sets the SI to user provided passed screening. If RN1 fails screening then the switch sends the default DN as RN1.

If the terminating agent is a SS7 trunk then the switch provides the RN1 as the Original Called Number (OCN) and the charge number. If the terminating agent is a MF trunk then the switch provides the RN1 as the ANI.

If there are multiple redirections during a call then the switch provides the RN1 and RN2 to the NI-PRI interface. The switch processes RN1 and RN2 separately.

If the terminating agent is a SS7 trunk then the switch provides the RN1 as the OCN and RN2 as the Redirecting Number (RGN). The charge number for SS7 trunks are identical to RGN. If the terminating agent is a MF trunk then the ANI is identical to RGN. The switch does not apply normal RN billing.

### Translations table flow

E911 Preferred DN does not affect translations table flow.

### Limitations and restrictions

The limitations and restrictions that follow apply to E911 Preferred DN.

- E911 Preferred DN is only for NI-PRI interfaces
- E911 Preferred DN pertains only to incoming 911, 0911, or 1911 calls on a NI-PRI interface.
- If the operating company does not datafill CLI selector in table LTDATA for an NI-PRI interface, then the CPN screening of non-911 calls does not



---

## E911 Preferred DN (continued)

---

occur. If the operating company datafills option E911DN, then the switch screens 911 calls.

*Note:* The switch can not edit the CPN of the 911 call because the operating company did not datafill CLI selector.

- If the operating company does not datafill the RN selector in table LTDATA for an NI-PRI interface, then RN screening of non-911 calls does not occur. If the operating company datafills option E911DN, then the switch screens the RNs for 911 calls.

*Note:* The switch can not edit the RN of the 911 call because the operating company did not datafill RN selector.

### Interactions

E911 Preferred DN does not interact with other functionalities.

### Activation and deactivation by the user

E911 Preferred DN does not require activation or deactivation by the user.

### Billing

The E911 Preferred DN feature does not prevent the generation of billing records. If an end user makes a 911 call and the operating company does not specify E911 Preferred DN, then the switch does generate a billing record. If the operating company does indicate feature E911 Preferred DN the switch continue to generates a billing record.

*Note:* The E911 Preferred DN feature does not apply normal billing number determination when an end user makes a 911 call. The switch sets the billing number to the validated CPN or the default DN.

### Station Message Detail Recording

E911 Preferred DN does not require Station Message Detail Recording.

### Office parameters used by E911 Preferred DN

E911 Preferred DN does not generate office parameters.

## E911 Preferred DN (end)

### Datafill sequence

The table that follows lists the tables that require datafill to put E911 Preferred DN into operation. You must enter data into the table in this order.

#### Datafill requirements for E911 Preferred DN

Table	Purpose of table
LTDATA	Logical Terminal Data contains service-related data associated with the logical terminal identifier (LTID).

### Datafill related to E911 Preferred DN for table LTDATA

The table that follows provides the datafill related to E911 Preferred DN for table LTDATA. This table includes only those fields that apply directly to E911 Preferred DN.

#### Datafill related to table LTDATA

Field	Subfield	Entry	Explanation and action
	Option	E911DN	Option. Enter option E911DN to provide the CPN or the default DN for incoming 911 calls.

### Datafill example for table LTDATA

The figure that follows shows sample datafill for table LTDATA.

#### MAP example for table LTDATA

LTDKEY	DATATYPE	DFLTCGN	OPTION
ISDN 108 DN DN	613 722 9999	E911DN CGN	\$
ISDN 108 DN DN	613 722 9999	E911DN DEFAULT	\$

### Translation verification tools

E911 Preferred DN does not use translation verification tools.

### SERVORD

E911 Preferred DN does not use the Service Order System (SERVORD).

---

## ISP Even Call Distribution

---

### Ordering codes

Functional group ordering code: NI000036

Functionality ordering code: not applicable

### Release applicability

NA010 and up

ISP Even Call Distribution was introduced in NA010.

### Prerequisites

This document includes all the data table information for this functionality. Complete use of this functionality can require software or hardware not described in this document.

### Description

ISP Even Call Distribution provides the following functionality to internet access providers (IAP) and internet service providers (ISP):

- an even distribution of calls across a set of possible trunk members  
To provide even call distribution, ISP Even Call Distribution introduces the following circular hunt selection algorithms:
  - CHCL and CHCCL (trunk group level)
  - SG\_CWCTH, SG\_CCWCTH, GRP\_CWCTH, and GRP\_CCWCTH (trunk member level)
- support of a maximum of 220 primary rate interface (PRI) trunk groups in a PRI route list

Before the ISP Even Call Distribution feature, the recommended maximum number of PRI routes to a route list was 50.

In the NA009 release, the Random and Circular Hunting feature introduced table SUPERTKG. Each tuple in this table is a super-group (a collection of up to 220 PRI trunk groups). With super-groups, the recommended maximum number of PRI routes in a route list is 220. This increased limit allows the association of a large trunk group configuration with a single destination, such as an ISP.

## ISP Even Call Distribution (continued)

---

- prevention of call retranslation between PRI trunk groups (and reduced use of real time) through the use of super-groups
- a maximum number of trunk group attempts

Setting a maximum number of trunk group attempts conserves real time during busy periods. With this limit, the switch searches only a fixed number of trunk groups during call routing. During busy periods, the switch returns an all trunks busy (ATB) indication instead of providing no treatment or delayed treatment to a caller. The maximum number of trunk group attempts can range from 1 to 220.

*Note:* ISP Even Call Distribution introduces a recommended maximum number of attempts of 50 (based on 23 members in each trunk group). A warning message displays if the operating company sets the maximum number of trunk group attempts to a value greater than 50.

## Operation

The circular hunt capability is an advantage for switches connected to ISPs. Before the ISP Even Call Distribution feature, the following problems existed in these switches:

- overuse of the first trunk group on the list
- retranslation used additional processor real time
- killer trunks repeatedly selected

ISP Even Call Distribution reduces or eliminates these problems.

### Changes to table control for routing tables

The ISP Even Call Distribution feature provides internet access providers (IAP) and internet service providers (ISP) an even call distribution of calls across a set of possible trunk members. It also supports a maximum of 220 routes in a PRI route list.

This feature provides circular hunt selection algorithms at the route (RTE) list and trunk group levels. To accomplish this, the feature uses two selection algorithms options in routing selector SG in the following tables:

- IBNRTE, IBNRT2, IBNRT3, IBNRT4
- OFRT, OFR2, OFR3, OFR4
- HNPSCONT, FNPACONT (RTEREF)
- ACRTE, PXRTE, CTRTE, FARTE, OFCRTE, FTRTE, NSCRTE

---

## ISP Even Call Distribution (continued)

---

Route selector SG applies to all PRI protocol variants and has the following three subfields:

- ALGORITHM specifies the trunk group selection method datafilled in table SUPERTKG. ISP Even Call Distribution introduces the following two additional algorithms:
  - CHCL (circular hunt clockwise direction)
  - CHCCL (circular hunt counterclockwise direction)
- ATTEMPTS specifies the maximum number of trunk group selection attempts (1–220) to find a free trunk group. With selection algorithms CHCL and CHCCL, the recommended maximum number of search attempts is 50.

*Note 1:* For the CHCL and CHCCL selection algorithms, if the ATTEMPTS value is greater than 50, the switch generates log report DFIL616. A table control warning message also displays if the operating company sets subfield ATTEMPTS to a value greater than 50.

*Note 2:* For more information on subfield ATTEMPTS and its effect during searches for a free trunk, refer to "Effect of ATTEMPTS value on real time and hit rate."

- SUPERTKG\_NAME—is an index to the tuple in table SUPERTKG that has the list of trunk groups.

## ISP Even Call Distribution (continued)

Table shows the field descriptions for the trunk group selection sequence in table TRKGRP.

### Field descriptions for table TRKGRP—subfield for selection sequence (Sheet 1 of 2)

Field	Subfield	Entry	Description
	SELSEQ	ASEQ, DSEQ, GRP_CWCTH, GRP_CCWCTH, LIDL, MIDL, SG_CWCTH, SG_CCWCTH, WIDEBAND	<p>Selection sequence. Enter one of the following:</p> <ul style="list-style-type: none"> <li>• ASEQ for ascending sequence</li> <li>• DSEQ for descending sequence</li> <li>• GRP_CWCTH for trunk group clockwise circular hunt. GRP_CWCTH is not recommended for use with the super group selection algorithms. The starting point is taken as the trunk member which is after the member that was searched last. The remaining members are searched in a clockwise direction until the last member of that trunk group is reached or a free trunk member is found. If no free trunk member is found, the search is continued from the first member of the trunk group up to the starting point (not including the starting point).</li> <li>• GRP_CCWCTH for trunk group counterclockwise circular hunt. GRP_CCWCTH is not recommended for use with the super group selection algorithms. The starting point is taken as the trunk member which is before the member that was searched last. The remaining members are searched in a counter-clockwise direction until the first member of that trunk group is reached or a free trunk member is found. If no free trunk member is found, the search is continued from the last member of the trunk group up to the starting point (not including the starting point).</li> <li>• LIDL for least idle hunt</li> <li>• MIDL for most idle hunt</li> </ul>

---

**ISP Even Call Distribution** (continued)

---

**Field descriptions for table TRKGRP—subfield for selection sequence (Sheet 2 of 2)**

Field	Subfield	Entry	Description
			<ul style="list-style-type: none"> <li>• SG_CWCTH for super group clockwise circular hunt. This entry is designed to be used with the CHCL super group selection algorithm. The starting point is taken as the trunk member that is after the member that was searched last. The remaining members are searched in a clockwise direction to find a idle trunk member until the last member of that trunk group is reached.</li> <li>• SG_CCWCTH for super group counterclockwise circular hunt. This entry is designed to be used with the CHCCL super group selection algorithm. The starting point is taken as the trunk member which is before the member that was searched last. The remaining members are searched in a counter- clockwise direction until the first member of that trunk group is reached to get a free trunk member. If no free trunk member is found, next trunk group is selected</li> <li>• WIDEBAND for multirate n X 64 DWS service</li> </ul>

Table shows the field descriptions for the trunk group selection sequence in table IBNRTE.

**Description of fields in table IBNRTE (Sheet 1 of 2)**

Field	Subfield	Entry	Description
IBNRTSEL		SG	IBN routing selector. Indicates that an attempt should be made to route to a trunk group from those in a tuple in table SUPERTKG. Enter SG and datafill subfields ALGORITHM, ATTEMPTS, and SUPERTKG_NAME.
	ALGORITHM	CHCL, CHCCL	Algorithm. Enter one of the following: <ul style="list-style-type: none"> <li>• CHCL (circular hunt in clockwise direction)</li> <li>• CHCCL (circular hunt in counterclockwise direction)</li> </ul>

**ISP Even Call Distribution** (continued)

**Description of fields in table IBNRTE (Sheet 2 of 2)**

Field	Subfield	Entry	Description
	ATTEMPTS	numeric (1–220)	Attempt number. the maximum number of trunk groups to be tested for a free trunk member.
	SUPERTKG_ NAME	alphanumeric (1–16 characters)	Super-trunk group name. Enter the name of the super-trunk group.

Figure shows an example of data in table IBNRTE and table SUPERTKG required for circular hunt.

**Example of circular hunt data in tables IBNRTE and SUPERTKG**

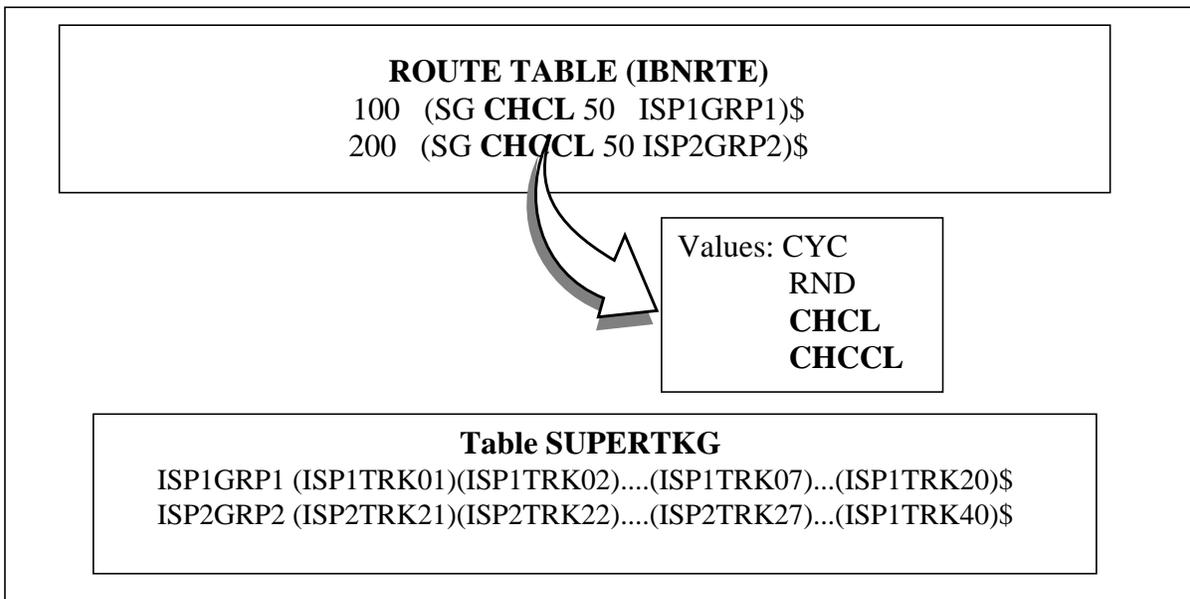

**Changes to table control for table TRKGRP**

ISP Even Call Distribution adds the following four values to subfield SELSEQ in table TRKGRP. These values indicate the type of selection algorithm to use in the trunk member selection. These new algorithms apply to Northern



---

## ISP Even Call Distribution (continued)

---

Telecom North America (NTNA) and Northern Telecom National ISDN (NTNI) PRI protocol variants only.

- SG\_CWCTH (super-group circular hunt in clockwise direction)
- SG\_CCWCTH (super-group circular hunt in counterclockwise direction)
- GRP\_CWCTH (trunk group member circular hunt in clockwise direction)
- GRP\_CCWCTH (trunk group member circular hunt in counterclockwise direction)

*Note:* In the following sections, the term “free trunk member” refers to an idle channel that has not processed a call in the current search cycle.

### **SG\_CWCTH selection algorithm**

With this algorithm, the search for a free trunk member starts with the member after the last searched member. The switch searches the remaining trunk members in a “clockwise” direction up to and including the last trunk member. If the switch does not find a free trunk member, it selects the next trunk group using the selection algorithm defined in the routing table

*Note:* For best results, use the SG\_CWCTH algorithm with the CHCL super-group selection algorithm defined in the routing table.

### **SG\_CCWCTH selection algorithm**

With this algorithm, the search for a free trunk member starts with the member before the last searched member. The switch searches the remaining trunk members in a “counterclockwise” direction up to and including the first trunk member. If the switch does not find a free trunk member, it selects the next trunk group using the selection algorithm defined in the routing table.

*Note:* For best results, use the SG\_CCWCTH algorithm with the CHCCL super-group selection algorithm defined in the routing table.

### **GRP\_CWCTH selection algorithm**

With this algorithm, the search for a free trunk member starts with the member after the last searched member. The switch searches the remaining members in a “clockwise” direction up to and including the last trunk member. If the switch does not find a free trunk member, the search continues from the first trunk member up to (but not including) the starting point.

*Note:* For best results, do not use the GRP\_CWCTH algorithm with the CHCL and CHCCL super-group selection algorithms. Use the GRP\_CWCTH algorithm for clockwise searches within a single NTNA or NTNI PRI trunk group.

## ISP Even Call Distribution (continued)

---

### GRP\_CCWCTH selection algorithm

With this algorithm, the search for a free trunk member starts with the member before the last searched member. The switch searches the remaining members in a “counter clockwise” direction up to and including the first trunk member. If the switch does not find a free trunk member, the search continues from the last trunk member up to (but not including) the starting point.

*Note:* For best results, do not use the GRP\_CCWCTH algorithm with the CHCL and CHCCL super-group selection algorithms. Use the GRP\_CCWCTH algorithm for counterclockwise searches within a single NTNA or NTNI PRI trunk group.

### Even call distribution at the trunk group and trunk member levels

Each entry in table SUPERTKG is a super-group. Each entry in the routing table contains the following:

- a route selector
- a selection algorithm (either CHCL or CHCCL), defined by subfield ALGORITHM
- a value that indicates the maximum number of attempts to find a free trunk group during call processing, defined by subfield ATTEMPTS
- an index into table SUPERTKG, defined by subfield SUPERTKG\_NAME

Call distribution occurs as follows when the switch uses route selector SG during call routing. (These steps are based on a single SG selector found in the routing table.)

1. The switch uses the SUPERTKG\_NAME entry in the routing table as an index into table SUPERTKG.
2. Based on the selection algorithm in the routing table, the switch selects a trunk group from the indexed tuple in table SUPERTKG.
3. If the trunk group has a free trunk member, the switch routes the call to the free member.
4. If the trunk group does not have a free trunk member, the switch searches the next trunk group in the same super-group.

The switch repeats this process until it finds a trunk group with a free trunk member.

If the switch reaches the ATTEMPTS value in the same super-group without finding a free member, the following occurs:

1. The switch sends an ATB indication.
2. The switch stops call routing

---

## ISP Even Call Distribution (continued)

---

### Selection algorithms

The switch performs the search for a free trunk member at both the trunk group level and the trunk member level.

At the trunk group level, ISP Even Call Distribution introduces the following selection algorithms for selecting a trunk group:

- CHCL (circular hunt in clockwise direction)
- CHCCL (circular hunt in counterclockwise direction)

At the trunk member level, ISP Even Call Distribution introduces the following selection algorithms for selecting a free trunk member:

- SG\_CWCTH (super-group circular hunt in clockwise direction)
- SG\_CCWCTH (super-group circular hunt in counterclockwise direction)
- GRP\_CWCTH (trunk group member circular hunt in clockwise direction)
- GRP\_CCWCTH (trunk group member circular hunt in counterclockwise direction)

## ISP Even Call Distribution (continued)

The following table shows the recommended combinations of these selection algorithms. Algorithms CHCL and CHCCL are at the RTE list level. Algorithms SG\_CWCTH and SG\_CCWCTH are at the member level.

### Recommended selection algorithms

Algorithms	SG_CWCTH	SG_CCWCTH
CHCL	This combination is the best to get a complete circular clockwise at the trunk group and member level.	Not Recommended. (This combination will not give a complete circular selection in either clockwise or counterclockwise direction.)
CHCCL	Not Recommended. (This combination will not give a complete circular selection in either clockwise or counterclockwise direction.)	This combination is the best to get a complete counterclockwise circular selection at the trunk group and member level.
<p><b>Note:</b> The switch does not block the operating company from using the CHCL/SG_CCWCTH and CHCCL/SG_CWCTH algorithms together. But, use of these algorithms together does not result in a complete circular selection in either the clockwise or counterclockwise direction. Nortel does not recommend use of these algorithms together.</p>		

### Even call distribution through CHCL and SG\_CWCTH

The combination of CHCL and SG\_CWCTH provides the best selection process for a complete clockwise search at the trunk group and member levels. Figure shows an example of table data entries for this combination.

---

**ISP Even Call Distribution** (continued)
 

---

**Example of table entries for CHCL and SG\_CWCTH combination**

<b>ROUTE TABLE (IBNRTE)</b> 100 (SG CHCL 50 ISP1GRP1) \$
<b>Table SUPERTKG</b> ISP1GRP1 (ISP1TRK01)(ISP1TRK02)....(ISP1TRK07)...(ISP1TRK60)\$
<b>Table TRKGRP</b> ISP1TRK01 PRA 0 NPDGP NCRT SG_CWCTH N (ISDN 11) \$ \$ ISP1TRK02 PRA 0 NPDGP NCRT SG_CWCTH N (ISDN 12) \$ \$ .....

For this example, call processing routes a call through table IBNRTE tuple 100. This starts a circular hunt search in the clockwise direction (CHCL) in table SUPERTKG tuple ISP1GRP1.

For the first call, the search starts from trunk group ISP1TRK01. For this trunk group, the SELSEQ field from table TRKGRP is SG\_CWCTH. The search for a free trunk member starts from the first member of ISP1TRK01 until it reaches the last member. If the selection process finds a free trunk member, it offers the trunk member to the call.

For subsequent calls, the search starts from the last accessed trunk group for routing the call (for example, ISP1TRK02). In the trunk group ISP1TRK02, the selection sequence (SELSEQ) is SG\_CWCTH. With this selection sequence, the search for a free member starts from the trunk member after the last searched trunk member and continues to (and includes) the last member in this (ISP1TRK02) trunk group. If the selection process cannot find a free trunk in this trunk group, it selects (in a clockwise direction) the next trunk group in the super group ISP1GRP1 to route the call.

Figure shows a representation of the selection process when CHCL and SG\_CWCTH are datafilled. The ellipse indicates that all members of the trunk groups in a super trunk group are searched as though they were all in one group.

**ISP Even Call Distribution** (continued)

Representation of the route selection process when CHCL and SG\_CWCTH are datafilled

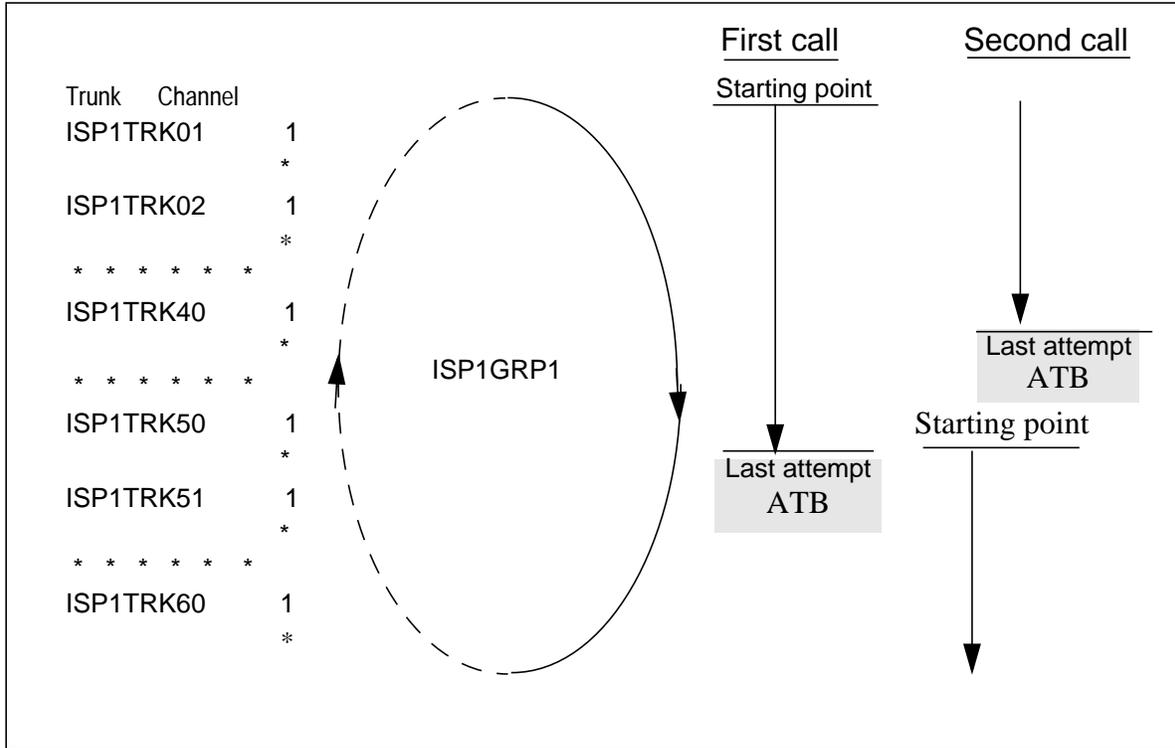

If 50 trunk groups (for example, from ISP1TRK01 to ISP1TRK50) are searched and no free trunk member is available, the DMS sends an ATB indication and stops the call routing process. When the call routing process accesses tuple 100 in table IBNRTE to route the next call, the search starts from the first trunk member of the trunk group ISP1TRK51 and continues in a clockwise direction. If the selection process finds no free member in trunk group ISP1TRK60, the search returns to the first trunk group (ISP1TRK01). Because the ATTEMPTS value in this example is set at 50, the search stops at ISP1TRK40, if an idle member cannot be found. The DMS switch sends an ATB indication and stops the call routing process.

**Even call distribution through CHCCL and SG\_CCWCTH**

The combination of CHCCL and SG\_CCWCTH provides the best selection process for a complete counterclockwise search at the trunk group and member levels. Figure shows an example of table data entries for this combination.

---

**ISP Even Call Distribution** (continued)

---

**Example of table entries for CHCCL and SG\_CCWCTH combination**

<b>ROUTE TABLE (IBNRTE)</b> 100 (SG CHCCL 50 ISP1GRP1) \$
<b>Table SUPERTKG</b> ISP1GRP1 (ISP1TRK01)(ISP1TRK02)....(ISP1TRK07)...(ISP1TRK60)\$
<b>Table TRKGRP</b> ISP1TRK01 PRA 0 NPDGP NCRT SG_CCWCTH N (ISDN 11) \$ \$ ISP1TRK02 PRA 0 NPDGP NCRT SG_CCWCTH N (ISDN 12) \$ \$ .....

For this example, a call is routed through table IBNRTE tuple 100. This starts a circular hunt search in a counterclockwise direction (CHCCL) in table SUPERTKG tuple ISP1GRP1.

For the first call, the search starts from trunk group ISP1TRK01. For this trunk group the SELSEQ field from table TRKGRP is SG\_CCWCTH. This starts the search from the last member of ISP1TRK01 and continues until it reaches the first member. If no free member is found, the call proceeds to the last trunk group (ISP1TRK60). If the selection process finds a free trunk member, the member is offered to the call.

For the subsequent calls, the selection process starts the search from the last accessed trunk group for routing the call (for example, ISP1TRK59). In trunk group ISP1TRK59, the SELSEQ is SG\_CCWCTH. This selection sequence starts the search from the trunk member previous to the last searched trunk member. The selection process searches up to the first member in this (ISP1TRK59) trunk group for a free member. If it cannot find a free member in this trunk group, the selection process selects the next trunk group (in reverse order) in the super group ISP1GRP1 to route the call.

If 50 trunk groups (for example, ISP1TRK01 and from ISP1TRK60 to ISP1TRK12) are searched and no free trunk member is available, the DMS switch sends an ATB indication and stops the call routing process. When the routing process accesses tuple 100 in table IBNRTE to route the next call, the search starts from trunk group ISP1TRK11 and continues in a

**ISP Even Call Distribution** (continued)

counterclockwise direction. If no free member is available in trunk group ISP1TRK01, the search proceeds to the last trunk group (ISP1TRK60) and continues the search for a free member. Because the ATTEMPTS value in this example is 50, the search for this call stops at ISP1TRK21, if an idle member cannot be found. The DMS switch sends an ATB indication and stops the call routing process.

Figure shows a representation of the route selection process when CHCCL and SG\_CCWCTH are datafilled.

**Representation of the route selection process when CHCCL and SG\_CCWCTH are datafilled**

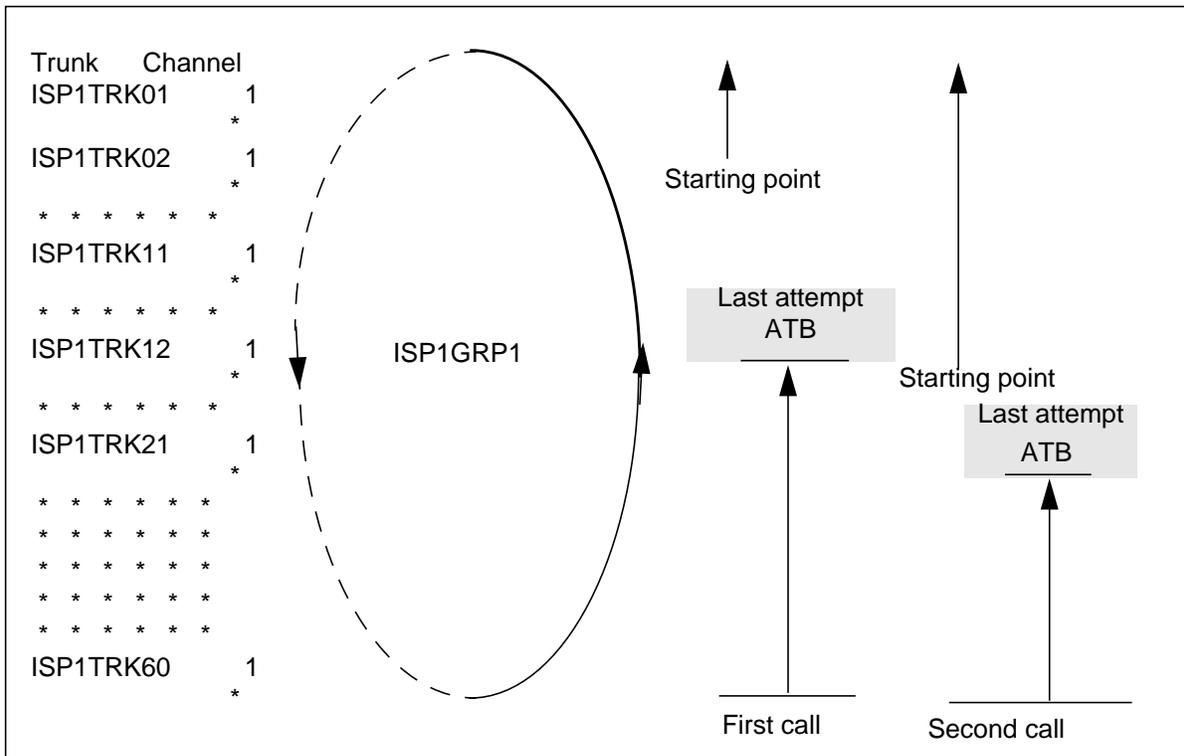

**Even call distribution through CHCL and SG\_CCWCTH**

The combination of CHCL and SG\_CCWCTH is not recommended. It is described here for informational purposes only. Figure shows an example of table data entries for this combination.



---

**ISP Even Call Distribution** (continued)
 

---

**Example of table entries for CHCL and SG\_CCWCTH combination**

<b>ROUTE TABLE (IBNRTE)</b> 100 (SG CHCL 50 ISP1GRP1) \$
<b>Table SUPERTKG</b> ISP1GRP1 (ISP1TRK01)(ISP1TRK02)...(ISP1TRK07)...(ISP1TRK60)\$
<b>Table TRKGRP</b> ISP1TRK01 PRA 0 NPDGP NCRT SG_CCWCTH N (ISDN 11) \$ \$ ISP1TRK02 PRA 0 NPDGP NCRT SG_CCWCTH N (ISDN 12) \$ \$ .....

For this example, a call is routed through table IBNRTE tuple 100. This starts a circular hunt search in a clockwise direction (CHCL) in table SUPERTKG tuple ISP1GRP1.

For the first call, the search starts from trunk group ISP1TRK01. For this trunk group the SELSEQ field from table TRKGRP is SG\_CCWCTH. This selection sequence starts the search for a free trunk member from the last member of ISP1TRK01 and continues until it reaches the first member. If the selection process finds a free trunk member, the member is offered to the call.

For subsequent calls, the search starts from the last accessed trunk group for routing the call (for example, ISP1TRK02). In trunk group ISP1TRK02 SELSEQ is SG\_CCWCTH. This selection sequence starts the search from the trunk member before the last accessed trunk member. It searches to the first member (including the first member) in the ISP1TRK02 trunk group. If the selection process cannot find a free trunk member in this trunk group, it selects the next trunk group from the super group (ISP1GRP1) in a clockwise direction.

**Even call distribution through CHCCL and SG\_CWCTH**

The combination of CHCCL and SG\_CWCTH is not recommended. It is described here for informational purposes only. Figure shows an example of table data entries for this combination.

---

**ISP Even Call Distribution** (continued)
 

---

**Example of table entries for CHCCL and SG\_CWCTH combination**

<b>ROUTE TABLE (IBNRTE)</b> 100 (SG CHCCL 50 ISP1GRP1) \$
<b>Table SUPERTKG</b> ISP1GRP1 (ISP1TRK01)(ISP1TRK02)...(ISP1TRK07)...(ISP1TRK60)\$
<b>Table TRKGRP</b> ISP1TRK01 PRA 0 NPDGP NCRT SG_CWCTH N (ISDN 11) \$ \$ ISP1TRK02 PRA 0 NPDGP NCRT SG_CWCTH N (ISDN 12) \$ \$ .....

For this example, a call is routed through table IBNRTE tuple 100. This starts a circular hunt search in counterclockwise direction (CHCCL) in table SUPERTKG tuple ISP1GRP1.

For the first call, the search starts from trunk group ISP1TRK01. For this trunk group, the SELSEQ field from table TRKGRP is SG\_CWCTH. This selection sequence starts the search from the first member of ISP1TRK01 and continues until it reaches the last member. If no free member is found, the call proceeds to the last trunk group (ISP1TRK60). If the selection process finds a free trunk member, the member is offered to the call.

**Even call distribution at the trunk member level—GRP\_CWCTH selection algorithm**

The GRP\_CWCTH is recommended for a clockwise search within a single NTNA or NTNI PRI trunk group. Figure shows an example of table data entries for this selection algorithm.

**Example of table TRKGRP entries for the GRP\_CWCTH algorithm**

<b>Table TRKGRP</b> ISP1TRK01 PRA 0 NPDGP NCRT GRP_CWCTH N (ISDN 11) \$ \$
---

## ISP Even Call Distribution (continued)

For this example, with the first call, search starts from the last member of trunk group ISP1TRK01 in the clockwise direction, until a free trunk member is found and the call is offered to it. If the last trunk member is reached and no free member is available for the call, the DMS switch sends an ATB indication and stops the call routing process.

For subsequent calls, the search starts from the trunk member after the last selected/searched member for routing the call. If no free trunk member is found from the starting point to the last trunk member, the search continues to the starting point (but does not include the starting point). If no free trunk member is found, the DMS switch sends an ATB indication and stops the call routing process.

In this selection method, the starting point of the search for the free member is always “c+1”, considering “c” as the last selected/searched trunk member in the trunk group.

Figure shows a representation of the route selection process when GRP\_CWCTH is datafilled in table TRKGRP.

### Representation of the route selection process when GRP\_CWCTH is datafilled in table TRKGRP

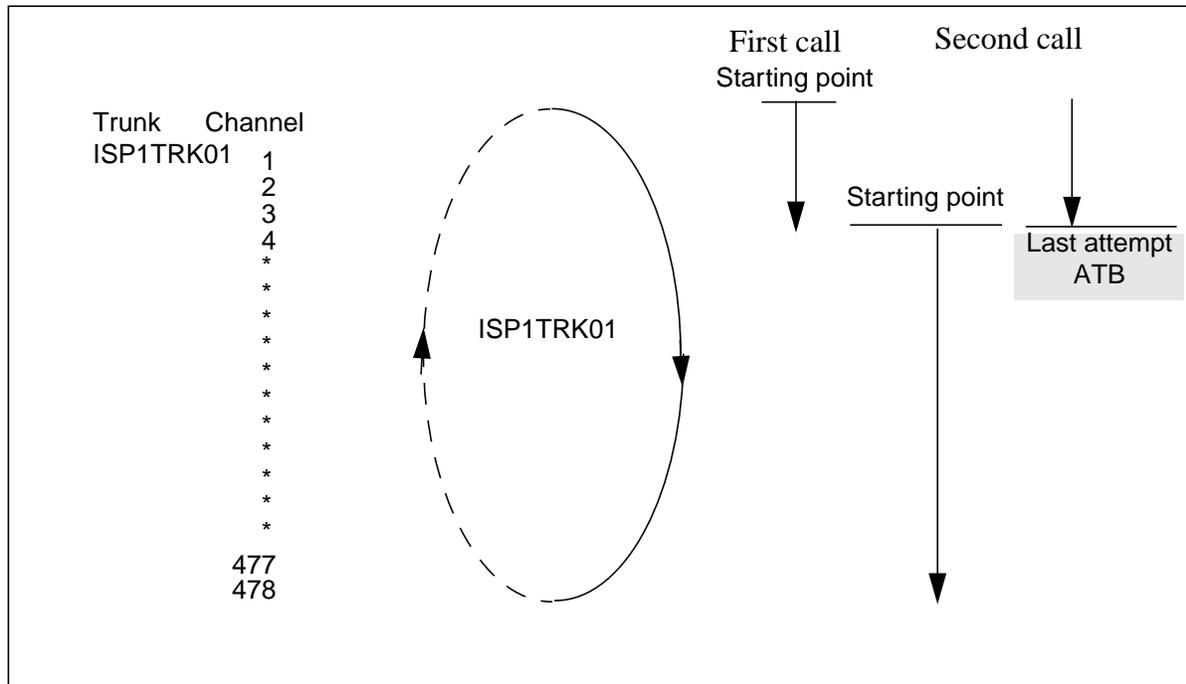

---

**ISP Even Call Distribution** (continued)
 

---

**Even call distribution at the trunk member level—GRP\_CCWCTH selection algorithm**

The GRP\_CCWCTH is recommended for a counterclockwise search within a single NTNA or NTNI PRI trunk group. Figure shows an example of table data entries for this selection algorithm.

**Representation of the route selection process when GRP\_CCWCTH is datafilled in table TRKGRP**

<b>Table TRKGRP</b> ISP1TRK01 PRA 0 NPDGP NCRT <b>GRP_CCWCTH</b> N (ISDN 11) \$ \$
---

For this example, the first call, search starts from the last member of trunk group ISP1TRK01 in the counterclockwise direction, until a free trunk member is found and the call is offered to it. If the first trunk member is reached and no free member is available for the call, the DMS switch sends an ATB indication and stops the call routing process.

For subsequent calls, the search starts from the trunk member before the last selected/searched member for routing the call. If no free trunk member is found from the starting point to the first trunk member, the search continues to the starting point (but does not include the starting point). If no free trunk member is found, the DMS switch sends an ATB indication and stops the call routing process.

In this selection method, the starting point of the search for the free member is always “c-1”, considering “c” as the last selected/searched trunk member in the trunk group.

Figure shows a representation of the route selection process when GRP\_CCWCTH is datafilled in table TRKGRP.

## ISP Even Call Distribution (continued)

Representation of the route selection process when GRP\_CCWCTH is datafilled in table TRKGRP

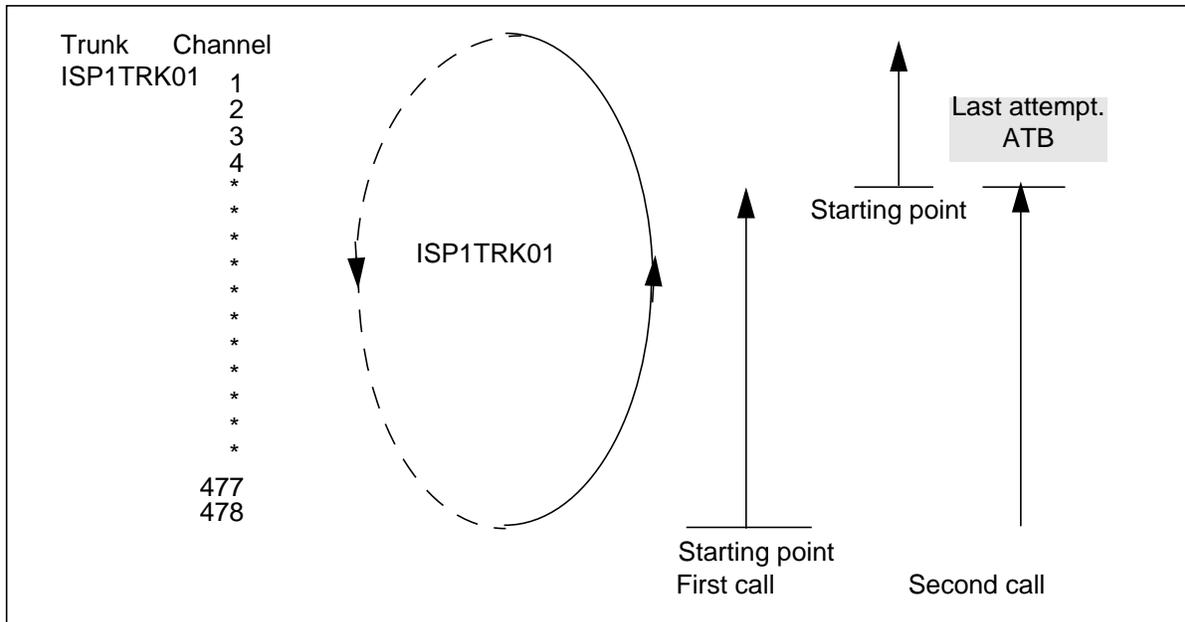

### Translations table flow

The ISP Even Call Distribution translations tables are described in the following list:

- The routing tables specify the route or routes to follow after call translation.  
The universal routing tables consist of tables OFRT, OFR2, OFR3, OFR4, HNPACONT.RTEREF, FNPACONT.RTEREF, ACRTE, PXRTE, CTRTE, FARTE, OFCRTE, FTRTE, and NSCRTE.  
The IBN tables consist of tables IBNRTE, IBNRT2, IBNRT3, IBNRT4.
- Table SUPERTKG (Super Trunk Group) associates up to 220 trunk groups together into super-groups. This association allows calls to be evenly distributed across the trunk groups.
- Table TRKGRP contains information that applies to the entire trunk group. This information includes the B-channel selection sequence, the LTID of the trunk group, and the billing DN.

The ISP Even Call Distribution translation process for clockwise circular hunting is shown in the flowchart that follows.

## ISP Even Call Distribution (continued)

**Table flow for ISP Even Call Distribution (clockwise circular hunting)**

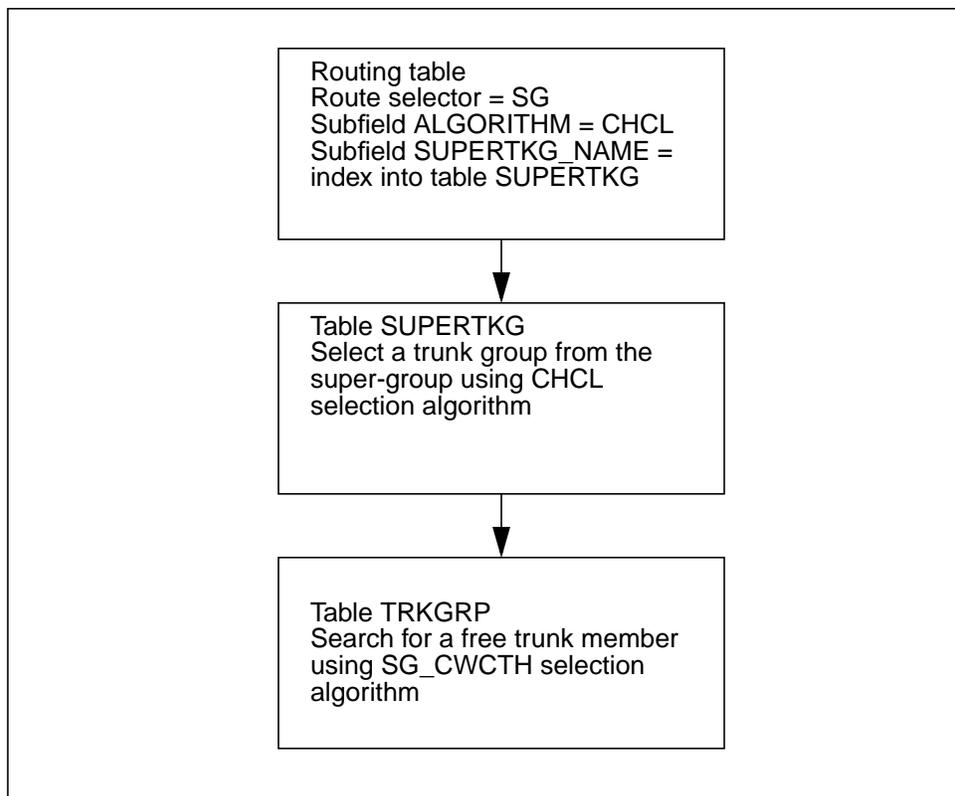

The following table lists the datafill content used in the flowchart.

**Datafill example for ISP Even Call Distribution (clockwise circular hunting)**

Datafill table	Example data
Routing table	100 (SG CHCL 50 ISP1GRP1) (SG CHCL 50 ISP2GRP2) \$
SUPERTKG	ISP1GRP1 (ISP1TRK01) (ISP1TRK02) (ISP1TRK03) (ISP1TRK04)
TRKGRP	ISP1TRK01 PRA 0 NPDGP NCRT SG_CWCTH N (ISDN 11) \$\$

The ISP Even Call Distribution translation process for counterclockwise circular hunting is shown in the flowchart that follows.

---

**ISP Even Call Distribution** (continued)
 

---

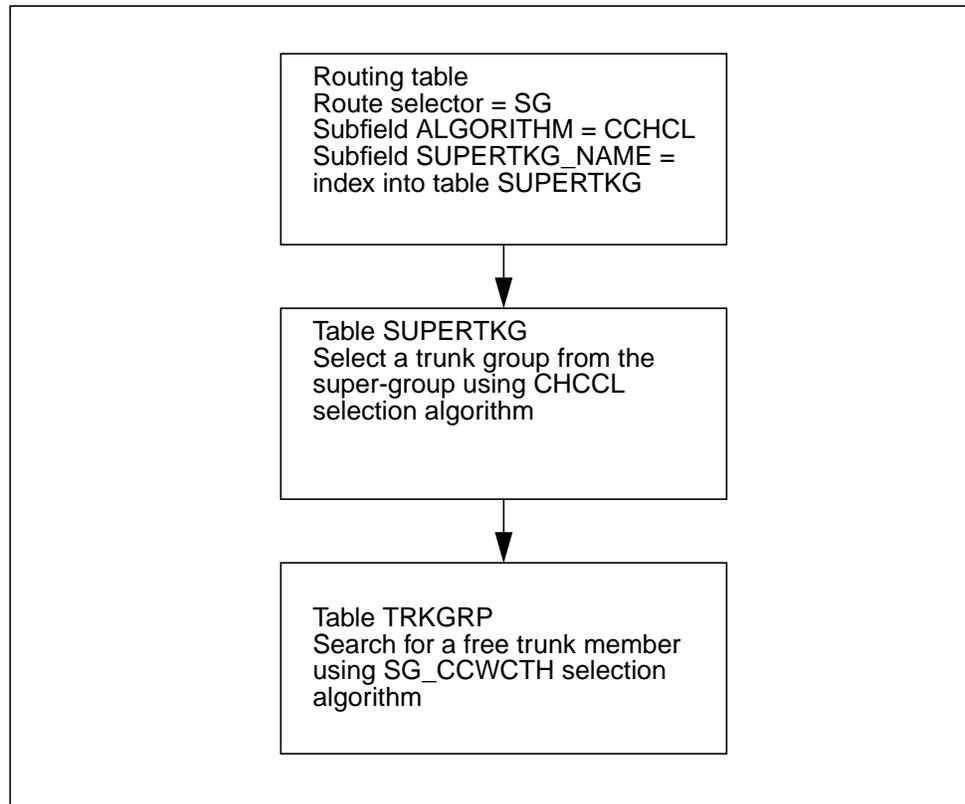
**Table flow for ISP Even Call Distribution (clockwise circular hunting)**

The following table lists the datafill content used in the flowchart.

**Datafill example for ISP Even Call Distribution (counterclockwise circular hunting)**

Datafill table	Example data
Routing table	100 (SG CHCCL 50 ISP1GRP1) (SG CHCCL 50 ISP2GRP2) \$
SUPERTKG	ISP1GRP1 (ISP1TRK01) (ISP1TRK02) (ISP1TRK03) (ISP1TRK04)
TRKGRP	ISP1TRK01 PRA 0 NPDGP NCRT SG_CCWCTH N (ISDN 11) \$\$

**Limitations and restrictions**

The following limitations and restrictions apply to ISP Even Call Distribution:

- ISP Even Call Distribution supports only PRI trunks.
- ISP Even Call Distribution supports only narrow-band PRI calls.
- ISP Even Call Distribution supports only NTNI and NTNA PRA trunk types.

## ISP Even Call Distribution (continued)

---

- Do not use the existing route list algorithms CYC, RND, and standard RTE advance with the SG\_CWCTH and SG\_CCWCTH selection algorithms. The SG\_CWCTH and SG\_CCWCTH selection algorithms are only designed for super-group at the RTE list level.
- For best results, use the GRP\_CWCTH and GRP\_CCWCTH selection algorithms with single trunk group configurations. Do not use these algorithms with the CHCL and CHCCL algorithms.
- Do not provision ASEQ and DSEQ with RTE list algorithms CHCL and CHCCL for creating the super-group.
- For complete circular selection with super-groups, use either the SG\_CWCTH or SG\_CCWCTH selection algorithm for all trunk groups in a super-group. Do not “mix” these selection algorithms among trunk groups in a super-group.
- The recommended ATTEMPTS value of 50 is based on a total of 23 B-channels in each trunk group. With non-facility associated signaling (NFAS), reduce the ATTEMPTS value so that the total number of B-channels searched in a super-group does not exceed 1150.
- For best results, do not use the following selection algorithms together. Use of these algorithms together does not result in a complete circular selection in either the clockwise or counterclockwise direction.
  - CHCL and SG\_CCWCTH
  - CHCCL and SG\_CWCTH

### Interactions

ISP Even Call Distribution does not affect any existing stage of call routing (for example, bearer capability routing).

### Activation/deactivation by the end user

ISP Even Call Distribution requires no activation or deactivation by the end user.

### Billing

ISP Even Call Distribution does not affect billing.

### Station Message Detail Recording

ISP Even Call Distribution does not affect Station Message Detail Recording.

### Datafilling office parameters

ISP Even Call Distribution does not affect office parameters.



---

## ISP Even Call Distribution (continued)

---

### Datafill sequence

The following table lists the tables that require datafill to implement ISP Even Call Distribution. The tables are listed in the order in which they are to be datafilled.

#### Datafill tables required for ISP Even Call Distribution

Table	Purpose of table
TRKGRP	Trunk group. This table contains information that applies to the entire trunk group. This information includes the B-channel selection sequence, the LTID of the trunk group, and the billing DN.
Routing tables	The routing tables specify the route or routes to follow after call translation.

### Datafilling table TRKGRP

The following table shows the datafill specific to ISP Even Call Distribution for table TRKGRP. Only those fields that apply directly to ISP Even Call Distribution are shown.

#### Datafilling table TRKGRP (Sheet 1 of 4)

Field	Subfield	Entry	Explanation and action
GRPKEY		see subfield	Group key. This field consists subfield CLLI.
	CLLI	alphanumeric (1–16 characters)	Common language location identifier. This subfield specifies the CLLI code assigned to the trunk group in table CLLI.
GRPINFO		see subfield	Variable group data. This field consists of subfields GRPTYP, TRAFSNO, PADGRP, NCCLS, SELSEQ, BILLDN, LTID, and OPTIONS. Only subfield SELSEQ applies to ISP Even Call Distribution.

## ISP Even Call Distribution (continued)

Datafilling table TRKGRP (Sheet 2 of 4)

Field	Subfield	Entry	Explanation and action
	SELSEQ	SG_CWCTH, SG_CCWCTH, GRP_CWCTH, GRPCCWCTH	<p>Selection sequence. This subfield determines the selection sequence for trunks within the trunk group. Enter one of the following values:</p> <ul style="list-style-type: none"> <li>Enter SG_CWCTH to specify super-group circular hunting in the clockwise direction.</li> </ul> <p>With this algorithm, the search for a free trunk member starts with the member after the last searched member. The switch searches the remaining trunk members in a “clockwise” direction up to and including the last trunk member. If the switch does not find a free trunk member, it selects the next trunk group using the selection algorithm defined in the routing table.</p> <p><b>Note:</b> For best results, use the SG_CWCTH algorithm with the CHCL super-group selection algorithm (defined in the routing table).</p> <ul style="list-style-type: none"> <li>Enter SG_CCWCTH to specify super-group circular hunting in the counterclockwise direction.</li> </ul> <p>With this algorithm, the search for a free trunk member starts with the member before the last searched member. The switch searches the remaining trunk members in a “counterclockwise” direction up to and including the first trunk member. If the switch does not find a free trunk member, it selects the next trunk group using the selection algorithm defined in the routing table.</p> <p><b>Note:</b> For best results, use the SG_CCWCTH algorithm with the CHCCL super-group selection algorithm (defined in the routing table).</p>

---

**ISP Even Call Distribution** (continued)

---

Datafilling table TRKGRP (Sheet 3 of 4)

Field	Subfield	Entry	Explanation and action
			<p>(Selection sequence continued)</p> <ul style="list-style-type: none"> <li>Enter GRP_CWCTH to specify trunk group member circular hunting in the clockwise direction.</li> </ul> <p>With this algorithm, the search for a free trunk member starts with the member after the last searched member. The switch searches the remaining trunk members in a “clockwise” direction up to and including the last trunk member. If the switch does not find a free trunk member, the search continues from the first trunk member up to (but not including) the starting point.</p> <p><b>Note:</b> For best results, do not use the GRP_CWCTH algorithm with the CHCL and CHCCL super-group selection algorithms. Use the GRP_CWCTH algorithm for clockwise searches with a single NTNA or NTNI PRI trunk group.</p> <ul style="list-style-type: none"> <li>Enter GRP_CCWCTH to specify trunk group member circular hunting in the counterclockwise direction.</li> </ul> <p>With this algorithm, the search for a free trunk member starts with the member before the last searched member. The switch searches the remaining members in a “counterclockwise” direction up to and including the first trunk member. If the switch does not find a free trunk member, the search continues from the last trunk member up to (but not including) the starting point.</p>

## ISP Even Call Distribution (continued)

### Datafilling table TRKGRP (Sheet 4 of 4)

Field	Subfield	Entry	Explanation and action
			(Selection sequence continued)
			<b>Note:</b> For best results, do not use the GRP_CCWCTH algorithm with the CHCL and CHCCL super-group selection algorithms. Use the GRP_CCWCTH algorithm for counterclockwise searches with a single NTNA or NTNI PRI trunk group

### Datafill example for table TRKGRP

The following example shows sample datafill for table TRKGRP.

### MAP display example for table TRKGRP

GRPKEY	GRPINFO
64K7DT0	PRA 0 NPDGP NCRT SG_CWCTH N (ISDN 20) \$ \$
64K8DT0	PRA 0 NPDGP NCRT SG_CCWCTH N (ISDN 21) \$ \$

---

**ISP Even Call Distribution** (continued)

---

**Methods of changing subfield SELSEQ value**

Changes to the trunk selection method for a trunk group (subfield SELSEQ) are allowed for some trunk selection methods, under certain conditions. The following table lists the methods of changing the value of subfield SELSEQ.

**Methods of changing SELSEQ value (Sheet 1 of 2)**

Current SELSEQ value	New SELSEQ value	Method of changing SELSEQ value
ASEQ or DSEQ (without feature AD3901) (Note)	SG_CWCTH, SG_CCWCTH, GRP_CWCTH, GRP_CCWCTH	Change the entry in table TRKGRP by placing the trunk group (all B- and D-channels) in installation busy (INB) state. The change is in effect from the next call after dynamic download is complete.
ASEQ or DSEQ (with feature AD3901) (Note)	SG_CWCTH, SG_CCWCTH, GRP_CWCTH, GRP_CCWCTH	Change the entry in table TRKGRP without changing the B- and D-channel states. The change is in effect from the next call after dynamic download is complete.
CWCTH or CCWCTH	SG_CWCTH, SG_CCWCTH, GRP_CWCTH, GRP_CCWCTH	Change the entry in table TRKGRP without changing the B- and D-channel states. The change is in effect from the next call after dynamic download is complete.
MIDL or LIDL	SG_CWCTH, SG_CCWCTH, GRP_CWCTH, GRP_CCWCTH	Deprovision the interface and provision the interface again.
SG_CWCTH, SG_CCWCTH, GRP_CWCTH, GRP_CCWCTH	ASEQ or DSEQ (without feature AD3901) (Note)	Deprovision the interface and provision the interface again. <ol style="list-style-type: none"> <li>1. Create a new trunk group with the desired SELSEQ value.</li> <li>2. Delete the current B- and D-channels from the existing trunk group.</li> <li>3. Add the B- and D-channels to the new trunk group.</li> </ol>
SG_CWCTH, SG_CCWCTH, GRP_CWCTH, GRP_CCWCTH	ASEQ or DSEQ (with feature AD3901) (Note)	Change the entry in table TRKGRP without changing the B- and D-channel states. The change is in effect from the next call after the dynamic download is complete.
<p><b>Note:</b> With DMS-250 feature AD3901 (Off-hook Queuing Enhancements), the ASEQ and DSEQ selection sequences are known as enhanced ASEQ/DSEQ.</p>		

## ISP Even Call Distribution (continued)

### Methods of changing SELSEQ value (Sheet 2 of 2)

Current SELSEQ value	New SELSEQ value	Method of changing SELSEQ value
SG_CWCTH, SG_CCWCTH, GRP_CWCTH, GRP_CCWCTH	CWCTH or CCWCTH	Change the entry in table TRKGRP without changing the B- and D-channel states. The change is in effect from the next call after the dynamic download is complete.
SG_CWCTH, SG_CCWCTH, GRP_CWCTH, GRP_CCWCTH	MIDL or LIDL	Deprovision the interface and provision the interface again.
<b>Note:</b> With DMS-250 feature AD3901 (Off-hook Queuing Enhancements), the ASEQ and DSEQ selection sequences are known as enhanced ASEQ/DSEQ.		

### Datafilling universal routing tables

Subfield ALGORITHM for route selector SG in the universal routing tables specifies the selection algorithm for trunk groups datafilled in table SUPERTKG. ISP Even Call Distribution adds the following two selection algorithms to subfield ALGORITHM:

- CHCL (circular hunt in clockwise direction)
- CHCCL (circular hunt in counterclockwise direction)

**Note:** The universal routing tables consist of tables OFRT, OFR2, OFR3, OFR4, HNPACONT.RTEREF, FNPACONT.RTEREF, ACRTE, PXRTE, CTRTE, FARTE, OFCRTE, FTRTE, and NSCRTE.

---

## ISP Even Call Distribution (continued)

---

The following table shows the datafill specific to ISP Even Call Distribution for the universal routing tables. Only those fields that apply directly to ISP Even Call Distribution are shown.

### Datafilling universal routing tables

Field	Subfield	Entry	Explanation and action
RTELIST		see subfield	Route list. This field consists of subfield RTESEL and subfields dependent on the value in subfield RTESEL. The route list consists of up to eight routes; each route has a selector and data.
	RTESEL	SG	Route selector. This field specifies the route selector. Enter SG (super-group) and datafill subfields ALGORITHM, ATTEMPTS, and SUPERTKG_NAME.
	ALGORITHM	CHCL, CHCCL	Algorithm. This subfield specifies the selection algorithm for trunk groups datafilled in table SUPERTKG. Enter one of the following values:  Enter CHCL to specify circular hunting in the clockwise direction. <ul style="list-style-type: none"> <li>• Enter CHCCL to specify circular hunting in the counterclockwise direction.</li> </ul>
	ATTEMPTS	numeric (1–50)	Maximum number of search attempts. This subfield specifies the maximum number of trunk groups to search for a free trunk member.  For ALGORITHM settings CHCL and CHCCL, set subfield ATTEMPTS to a value less than or equal to 50. This recommended limit reduces real-time use during searches in the 220 possible trunk groups in table SUPERTKG.
	SUPERTKG_NAME	alphanumeric (1–16 characters)	Super-group name. This subfield specifies the super-group name from table SUPERTKG.

## ISP Even Call Distribution (continued)

### Datafill example for universal routing tables

The following example shows sample datafill for routing tables HNPACONT.RTEREF, FNPACONT.RTEREF, ACRTE, PXRTE, CTRTE, FARTE, OFCRTE, FTRTE, and NSCRTE.

### MAP display example for tables HNPACONT.RTEREF, FNPACONT.RTEREF, ACRTE, PXRTE, CRTE, FARTE, OFCRTE, FTRTE, and NSCRTE

XLANAME	RTEREF	RTELIST
XLA1	155	(SG CHCL 10 ISP4GRP1) \$

The following example shows sample datafill for tables OFRT, OFR2, OFR3, and OFR4.

### MAP display example for tables OFRT, OFRT2, OFR3, OFR4

RTEREF	RTELIST
155	(SG CHCL 10 ISP4GRP1) \$

### Warning message for universal routing tables

The following warning message applies to the universal routing tables.

### Warning message for universal routing tables

Warning message	Explanation and action
Warning: Recommended ATTEMPTS value for CHCL and CHCCL is 50	For ALGORITHM settings CHCL and CHCCL, set subfield ATTEMPTS to a value less than or equal to 50.

### Datafilling IBN routing tables

Subfield ALGORITHM for route selector SG in the IBN routing tables specifies the selection algorithm for trunk groups datafilled in table



---

## ISP Even Call Distribution (continued)

---

SUPERTKG. ISP Even Call Distribution adds the following two selection algorithms to subfield ALGORITHM:

- CHCL (circular hunt in clockwise direction)
- CHCCL (circular hunt in counterclockwise direction)

*Note:* The IBN routing tables consist of tables IBNRTE, IBNRT2, IBNRT3, and IBNR4.

The following table shows the datafill specific to ISP Even Call Distribution for the IBN routing tables. Only those fields that apply directly to ISP Even Call Distribution are shown.

### Datafilling IBN routing tables (Sheet 1 of 2)

Field	Subfield	Entry	Explanation and action
RTE		1–1023 or blank	IBN route reference index. This field specifies the route reference number that is assigned to the route list.
RTELIST		see subfield	Route list. This field consists of subfield IBNRTSEL.
	IBNRTESEL	SG	IBN route selector. This field specifies the route selector. Enter SG (super-group) and datafill subfields ALGORITHM, ATTEMPTS, and SUPERTKG_NAME.
	ALGORITHM	CHCL, CHCCL	Algorithm. This subfield specifies the selection algorithm for trunk groups datafilled in table SUPERTKG. Enter one of the following values: <ul style="list-style-type: none"> <li>• Enter CHCL to specify circular hunting in the clockwise direction.</li> <li>• Enter CHCCL to specify circular hunting in the counterclockwise direction.</li> </ul>

## ISP Even Call Distribution (continued)

### Datafilling IBN routing tables (Sheet 2 of 2)

Field	Subfield	Entry	Explanation and action
	ATTEMPTS	numeric (1–50)	<p>Maximum number of search attempts. This subfield specifies the maximum number of trunk groups to search for a free trunk member.</p> <p>For ALGORITHM settings CHCL and CHCCL, set subfield ATTEMPTS to a value less than or equal to 50. This recommended limit reduces real-time use during searches in the 220 possible trunk groups in table SUPERTKG.</p>
	SUPERTKG_NAME	alphanumeric (1–16 characters)	Super-group name. This subfield specifies the super-group name from table SUPERTKG.

### Datafill example for IBN routing tables

The following example shows sample datafill for the IBN routing tables.

### MAP display example for IBN routing tables

RTE	RTELIST
155	(SG CHCL 10 ISP4GRP1) \$

### Warning message for IBN routing tables

The following warning message applies to the IBN routing tables.

### Warning message for universal routing tables

Warning message	Explanation and action
Warning: Recommended ATTEMPTS value for CHCL and CHCCL is 50	For ALGORITHM settings CHCL and CHCCL, set subfield ATTEMPTS to a value less than or equal to 50.

---

## ISP Even Call Distribution (continued)

---

### Effect of ATTEMPTS value on real time and hit rate

The following table lists the maximum number of attempts needed to find a free trunk member with varying ATTEMPTS values. The values listed in the table are based on the following conditions:

- Traffic to the ISP is high.
- Table TRKGRP and the routing tables contain either of the following sets of datafill:
  - subfield SELSEQ in table TRKGRP set to SG\_CWCTH and subfield ALGORITHM in the routing table set to CHCL
  - subfield SELSEQ in table TRKGRP set to SG\_CCWCTH and subfield ALGORITHM in the routing table set of CCHCL
- The super-group defined in table SUPERTKG contains X trunk groups.
- The super-group defined in table SUPERTKG contains only one free trunk member.

The following table shows the effect of the ATTEMPTS value on real time and hit rate.

### Effect of ATTEMPTS value on real time and hit rate

Percentage of super-group searched (ATTEMPTS/X) X 100%	Maximum number of call attempts needed to find a free trunk member
10 %	11
25%	5
50%	3
75%	2
100%	1

### Translation verification tools

Before the ISP Even Call Distribution feature, the TRAVER tool traversed the routing table (for example, table IBNRTE). The tool listed the trunk group from the current route in its output.

With the ISP Even Call Distribution feature, the TRAVER tool works in the same way, with the following exception. For route selector SG, the TRAVER tool indexes into table SUPERTKG and finds the current trunk group for the super-group. The tool lists that trunk group in its output.

---

## ISP Even Call Distribution (end)

---

The following example shows the output from TRAVER when it is used to verify ISP Even Call Distribution.

### TRAVER output example for ISP Even Call Distribution

```
> TRAVER L 5551000 8035551008 B
TABLE IBNLINES
ISDN 00 0 02 00 0 DP STN IBN 5551000 LONS634 0 0 613 $
TABLE DNATTRS
TUPLE NOT FOUND
TABLE DNGRPS
613 555 1000 1000
(PUBLIC (ADDRESS 613 555 1000) (NAME FIRST) $) $
TABLE IBNFEAT
TUPLE NOT FOUND
TABLE CUSTSTN
TUPLE NOT FOUNDTABLE OFCVAR
AIN_OFFIE_TRIGGRP NIL
AIN Orig Attempt TDP: no subscribed trigger.
TABLE NCOS
LONS634 0 0 0 0 (XLAS LONSXLA FEATXLA NDGT) (OCTXLA FETXLA) $
TABLE CUSTHEAD: CUSTGRP,PRELIMXLA, CUSTXLA,FEATXLA,VACTRMT, AND DIGCOL
LONS634 NXLA LONSXLA FEATXLA 0 NDGT
TABLE DIGCOL
NDGT specified: digits collected individually
TABLE IBNXLA: XLANAME LONSXLA
LONSXLA 803 ROUTE N Y 3 Y 3 15 NDGT N T IBNRTE 101 $
TABLE DIGCOL
NDGT specified: digits collected individually
AIN Info Collected TDP: no subscribed trigger.
TABLE FNPA7DIG
613 555 555 613
AIN Info Analyzed TDR: no subscribed trigger.
TABLE IBNRTE
101 SG CHCL 45 NEW1
. TABLE SUPERTKG
. NEW1 (64K6DT0) $
EXIT TABLE IBNRTE

*** TRAVER: SUCCESSFUL CALL TRACE ***
DIGIT TRANSLATIN ROUTE

1 64K6DT0          N CDN E164 NA 8035551008 NIL_NSF  BC SPEECH

TREATMENT ROUTES. TREATMENT IS: GNCT
1 8OFLO
2 LKOUT

*** TRAVER: SUCCESSFUL CALL TRACE ***
```

## SERVORD

ISP Even Call Distribution does not use SERVORD.

---

## Networked ACD on PRA

---

### Ordering codes

Functional group ordering code: ACD00004

Functionality ordering code: ACD00010

### Release applicability

BCS29 and up

### Requirements

To operate, Networked ACD on PRA requires the following:

- BAS Generic, BAS00003
- ACD Base, ACD00001
- MDC Minimum, MDC00001
- MDC MBS Minimum, MDC00007
- NI0 ISDN Base, NI000007
- NI0 ISDN PRI Base, NI000022

### Description

The automatic call distribution (ACD) groups are on multiple nodes. The system uses integrated services digital network (ISDN) primary rate interface (PRI) links to connect to the nodes. the Networked ACD on PRA feature package allows the system to group the nodes logically in a supergroup.

#### Network ACD–TCAP support

This package uses the improved Common Channel Signaling No. 7 (CCS7) transaction ability application part (TCAP) messaging support. The CCS7 TCAP supports load status information updates and logical overflow of ACD calls. The updates and calls occur between the DMS-100 switches, across the CCS7 links.

#### NACD prework–TCAP SCCP decoupling

The signaling connection control part (SCCP) was the only transport medium. The PRI introduces a second transport medium. This feature separates TCAP messaging from SCCP. Users can choose the transport medium, SCCP or PRI.

### Operation

The setup protocol messages contain call types. For PRI, The call type determines the translations. The system uses translations to route an incoming call. The call type is important to the local PRI, When the call enters the next

## Networked ACD on PRA (continued)

---

exchange, the system discards the call type. Later parts of the same call can have different call types.

**Note:** Use of the integrated service access (ISA) route selector to route a call to a PRI trunk is optional. Use of the ISA route selector is optional if the call type is private. You can use route selectors S or N to route private and public calls to a PRI trunk. The ISA route selector generates a numbering plan indicator (NPI) and network specific facilities (NSF) for the call. If a call uses another route selector, the system generates an NPI. The system passes the NPI to the terminating node.

The setup protocol message contains information about a call. With ISA, the two information elements in the setup message are the NPI and NSF. the information these elements contain, combined with the switch datafill, determine the call type and the translations for the PRI call.

### Numbering plan indicator

The called party number part of the setup message contains the NPI. The NPI indicates the numbering plan as public or private. The numbering plan refers to the called number.

#### **Public.**

When the called party number has an NPI equal to E.164, a default can occur. To support the connection, the system routes the call to public network facilities. An example of the public network facilities is the central office trunks. The called number conforms to the public network numbering plan E.164.

#### **Private.**

When the NPI is private, the called number conforms to the private numbering plan of the customer group. An example of a private network numbering plan is the Electronic Switched Network (ESN). The system uses facilities to route private calls. Examples of these facilities are tie trunks or foreign exchange lines.

### Network specific facilities

The NSF information element indicates the network facilities to use for the call. Incoming calls can use the NSF to access a specified service.

---

## Networked ACD on PRA (continued)

---

The NSF information element contains the following:

- a service selector that indicates the requested type of service. The different types of service include the following: FX, TIE, INWATS, or OUTWATS.
- an optional service identifier. The service identifier indicates the facility to use to route the call. An example of a service identifier is the zone number for an OUTWATS call.

### Translations for PRI call originations

A PRI call origination is an incoming call to the DMS-100 switch from an adjacent node over a PRI trunk.

The following steps describe how to access tables to translate an incoming PRI call.

1. The DMS-100 receives the setup message. The NSF and NPI are mapped to a call type with the following value:
  - a. If an NSF is not present, the call type is the value of the NPI.
  - b. If the NSF is present, the call type is the value of the NSF.
2. To determine the characteristics of the originating trunk group, the switch accesses table TRKMEM, table TRKSGRP, and table TRKGRP. Table TRKGRP contains the logical terminal identifier (LTID) assigned to the trunk.
3. Access to table LTDEF occurs through the LTID from table TRKGRP. Table LTDEF determines the access privileges. The access privileges are assigned to the LTID.
4. Access to table LTCALLS occurs through the LTID from table TRKGRP and the call type. Table LTCALLS, field XLARTE determines the next step in translations. Digit translation takes place with the called number digits. The number digits section of the called party number information element stores the called number digits.

The number digits can include prefix digits for a preferred inter-LATA carrier (10xxx digits).

The table accessed in the DMS-100 for an incoming call over a PRI trunk appear in the following figure.

## Networked ACD on PRA (continued)

### Originating PRI call incoming to the DMS-100 switch

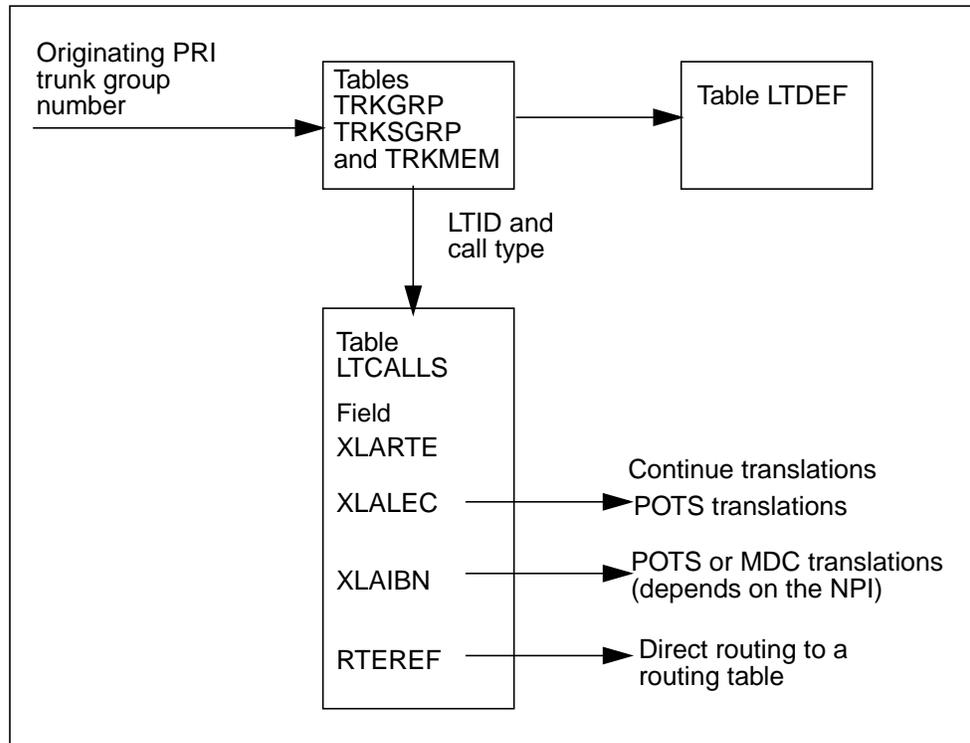

### Translations for PRI terminations

A PRI termination is an outgoing call from the DMS-100 switch to an adjacent node over a PRI trunk.

A call can terminate at a PRI trunk and the system can route the call to an adjacent node. When this event occurs, a routing table provides the trunk group common language location identifier (CLLI). The call terminates at the specified trunk group CLLI. The routing tables are as follows:

- OFRT
- IBNRTE
- HNPACONT.RTEREF
- FNPACONT.RTEREF
- FNPACONT.FNPASTS.RTEREF



---

## Networked ACD on PRA (continued)

---

From the routing table, the call proceeds with the translation process as follow:

- In the routing table, the ISA route selector specifies the CLLI of the trunk group to route calls to a specified PRI trunk group. The CLLI value is for access to table TRKGRP.
- Table TRKGRP contains the LTID of the trunk. With the LTID from table TRKGRP and the call type from the routing table, access to table LTCALLS occurs next.
- Table LTCALLS determines if the call type is acceptable on the trunk. If a tuple in table LTCALLS matches the LTID and call type, the call is acceptable. The call routes over the trunk to the terminating node. The NPI and NSF are forwarded to the node in the setup protocol message.

*Note:* If tuples in table LTCALLS do not match the LTID and call type, the system blocks the call. The caller receives treatment.

The ISA route selector is different from other route selectors. The ISA selector causes the system to generate an NPI and NSF for the outgoing call. The NPI and NSF go to the terminating node in the setup protocol message. Use of the ISA route selector to route a call to a PRI trunk is optional. Use of ISA route selector is optional if the call type is public or private. Route selectors like S or N route public and private calls to a PRI trunk. The ISA route selector generates an NPI and NSF for the call. If the use of other selectors occurs, the selector generates an NPI and passes the NPI to the terminating node.

To generate a billing record with the ISA route selector, set up translations to route the call through a virtual facilities group (VFG). When you enter data for the ISA route selector in a routing table, you can specify a digit manipulation index. The digit manipulation index points to table DIGMAN and allows modification of the called number digits before outpulsing.

The basic translations flow for a call that terminates to a PRI trunk group appears in the following diagram.

## Networked ACD on PRA (continued)

### Originating PRI call incoming to the DMS-100 switch

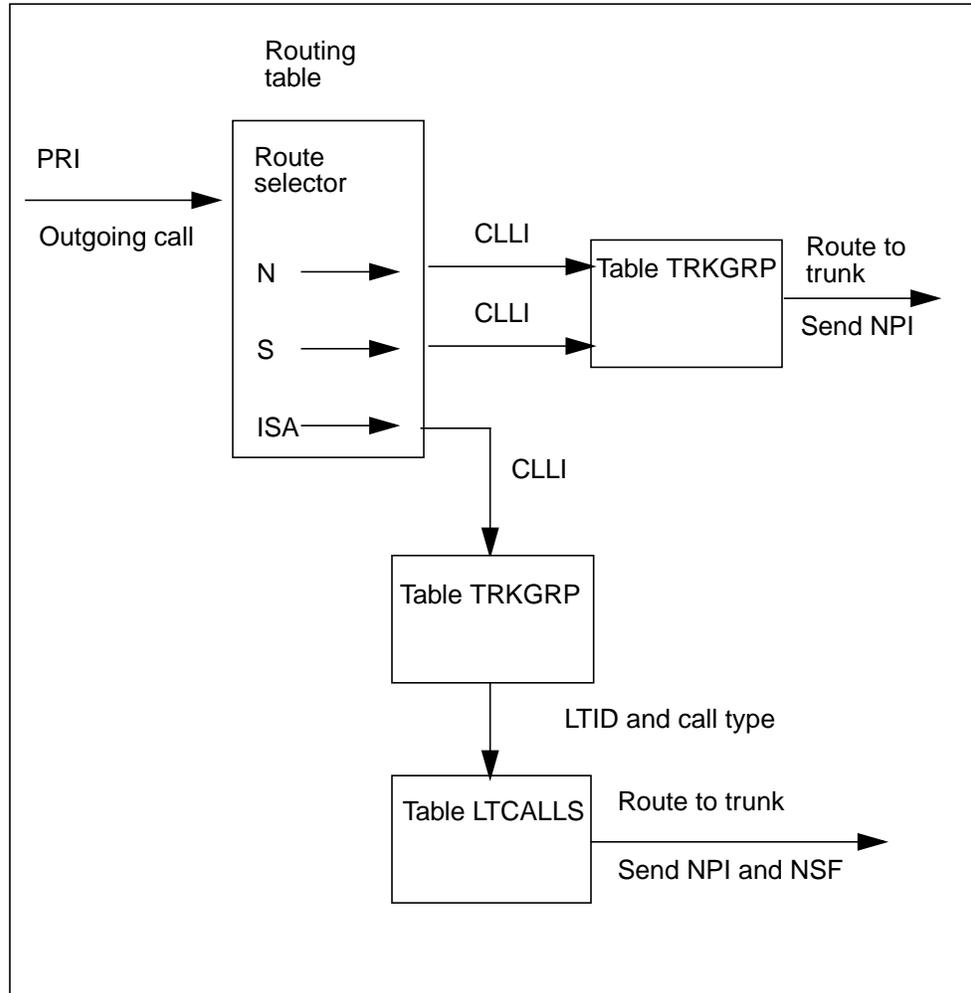

### Translations table flow

The Networked ACD on PRA translations tables appear in the following list:

- Table NACDGRP designates ACD groups as NACD groups. Table NACDGRP designates when and under what conditions networking for these NACD groups occurs.
- Table ACDGRP contains options that can affect NACD networking and queuing operations. The incoming queue accepts calls based on field MAXQSIZ or MAXWAIT. Field MAXQSIZ is for the maximum call queue size and MAXWAIT is for the maximum wait time. Calls wait in the physical queue for a specified period. Each NACD group that overflows these calls must have the option time delay overflow (TMDELOFL)

---

**Networked ACD on PRA** (continued)

---

entered in this table. When NACD groups accept overflow calls from other NACD groups, table ACDGRP must contain a definition of the option OVFLINQ.

- Table CUSTNTWK provides the network name for a customer group and global numeric identifier.
- Table REMNACD provides routing information associated with NACD groups on remote switches.
- Table TCAPTRID allocates memory for simultaneous NACD data transfer, like a resource index between two points or switches.

The Networked ACD on PRA translation process appears in the flowchart that follows.

**Table flow for Networked ACD on PRA**

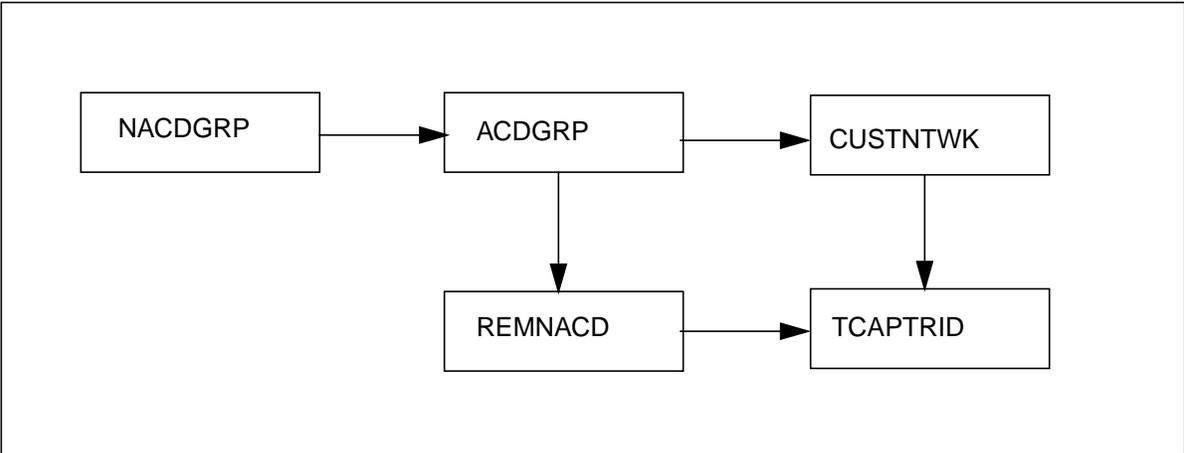

## Networked ACD on PRA (continued)

The data content in the flowchart appears in the following table. The ACD group is ACDGRP1, and the customer group is MDC1.

### Datafill example for Networked ACD on PRA

Datafill table	Example data
ACDGRP	ACDGRP1 MDC1 15 IBNRTE 100 IBNRTE 401 5 N 5 20 Y POOLA SUBPOOLA N \$ Y 5 10 15 WAIT N Y 5 NONE N Y Y OFRT 1003 (TMDELOFL 30 ALLPRIO) (OVFLINQ OLDEST 15) \$
NACDGRP	ACDGRP1 10 50 400 Y 90 10 100 (REM ACDGRP2 200 REM ACDGRP3 100) \$
REMNACD	ACDGRP2 91932555100 IBNRTE 31 \$ ACDGRP3 9195628900 IBNRTE 32 \$
CUSTNTWK	MDC1 PUBLIC 2 \$ \$
TCAPTRID	NACD 125 0

### Limitations and restrictions

Networked ACD on PRA has no limitations or restrictions.

### Interactions

The interactions between Networked ACD on PRA and other functionalities appear in the following paragraphs.

With ACD Called Name/Called Number Display (if space permits) the ACD name and number appear on the second line of the agent set if conditions occur as follows:

- a call overflows from a source ACD group to another ACD group, called the destination group
- the destination group has the ACDDISP option assigned in table ACDGRP

The ACD name and number of the source group are in table REMNACD.

### Activation/deactivation by the end user

Networked ACD on PRA does not require activation or deactivation by the end user.

---

## Networked ACD on PRA (continued)

---

### Billing

Networked ACD on PRA does not affect billing.

### Station Message Detail Recording

Networked ACD on PRA does not affect Station Message Detailed Recording.

### Datafilling office parameters

Networked ACD on PRA does not affect office parameters.

### Datafill sequence

The tables that require data to implement Networked AD on PRA appear in the following table. The tables are listed in the order in which they are datafilled. This datafill sequence assumes that the feature has a customer group and routing plan specified.

#### Datafill requirements for Networked ACD on PRA (Sheet 1 of 2)

Table	Purpose of table
CLLI	Common language location identifier. Assigns codes to trunk groups.
PADDATA	Pad data table. Defines the loss and level plan for PRI.
LTCINV	Line trunk controller inventory table. Contains a list of the ISDN digital trunk controller (DTC) and line trunk controller (LTC) peripheral modules. This table identifies the following: <ul style="list-style-type: none"> <li>the location of the hardware</li> <li>the load and executive programs required</li> <li>the C-side DS-30 link connections to the network modules</li> </ul>
CARRMTC	Carrier maintenance control table. Contains the attributes of the DS-1 links that terminate to the DTCI/LTCI. This table defines the line coding and frame formats for the DS-1 and provides maintenance control information for the links.
LTCPSINV	Line trunk controller P-side link inventory table. Contains the P-side link assignments for the DTCI and LTC. These assignments define the DS-1 links to the adjacent node.
ADJNODE	Adjacent node table. Identifies the name and type of node that connects to the DMS-100 by a PRI.
TRKGRP (PRA)	Primary rate access trunk group (type PRA) table. Defines the data associated with each PRI trunk.

## Networked ACD on PRA (continued)

### Datafill requirements for Networked ACD on PRA (Sheet 2 of 2)

Table	Purpose of table
TRKGRP (IBNT2)	IBN 2-way trunk group (type IBNT2) table. Defines the data associated with each IBNT2 trunk group.
TRKMEM	Trunk member table. Defines the B-channels in each trunk group.
LTGRP	Logical terminal group table. Defines the names of logical groups and the options for each group.
LTDEF	Logical terminal definition table. Defines logical terminals and access privileges.
LTMAP	Logical terminal map table. Assigns each PRI LTID, entered in table LTGRP, to a trunk group CLLI.
LTCALLS	Logical terminal calls table. Specifies the types of calls that can route over each PRI trunk group. This table defines the first translations for each trunk group and call type.
NETNAMES	Internal logical network names table. Defines the logical network to which the customer group belongs.
TCAPTRID	Transaction identifier table. Defines the number of TCAP transaction IDs that NACD requires.
REMNACD	Remote network automatic call distribution table. Provides the routing information associated with an NACD group on a remote switch.
NACDGRP	Network automatic call distribution group table. Defines and describes NACD groups.
CUSTNTWK	Customer group network table. Defines the network name for a customer group and a predetermined global numeric ID in a specified network name used for the customer group.
MSGRTE	PRA facility message routing table. Routes PRI facility messages.

---

**Networked ACD on PRA (continued)**

---

**Datafilling table TCAPTRID**

Datafill for Networked ACD on PRA for table TCAPTRIS appears in the following table. Only the fields that directly apply to Networked ACD on PRA are shown.

Field	Subfield	Entry	Explanation and action
TCAPAPPL		NACD	Transaction ability application part application. Enter NACD to allocate TCAP transaction IDs for NACD.
NUMTRIDS		0–32,767	Number of transaction IDs. Enter the number of transaction IDs that the application requires.

**Datafill example for table TCAPTRID**

Sample datafill for table TCAPTRID appears in the following example. In this example, 125 transaction IDs are allocated for NACD.

**MAP example for table TCAPTRID**

TCAPAPPL	NUMTRIDS	NUMCOMPS
NACD	125	0

## Networked ACD on PRA (continued)

### Datafilling table REMNACD

Datafill for Networked ACD on PRA for table REMNACD appears in the following table. Only those fields that directly apply to Networked ACD on PRA are shown.

#### Datafilling table REMNACD

Field	Subfield	Entry	Explanation and action
REMGROUP		alphanumeric	Remote NACD group. Enter the 1–16 character alphanumeric name of the remote NACD group.
REMOTEDN		alphanumeric	Remote directory number. Enter the directory number (DN) of the remote NACD group.
ROUTE		IBNRTE, IBNRT2, IBNRT3, IBNRT4, 0–1023	Route. Enter the table name and index the system uses to route calls to the remote NACD group.
OPTIONS		\$, NONDMS	Options. Enter NONDMS if the remote NACD group is in a non-DMS switch. For other conditions, enter \$. If you enter NONDMS, the system presents subfield TRGTRI.
	TRGTRI	alphanumeric	Target resource index. Enter the hard-coded resource index (RI) for the non-DMS remote NACD group.

#### Datafill example for table REMNACD

Sample datafill for table REMNACD appears in the following table. In this example, the NACD groups STOREA and XSUPPORT appear as remote NACD groups.

#### MAP example for table REMNACD

REMGROUP	REMOTEDN	ROUTE	OPTIONS
STOREA	9193625000	IBNRTE 31	\$
XSUPPORT	9193625000	IBNRTE 31	\$



---

**Networked ACD on PRA** (continued)

---

**Datafilling table NACDGRP**

Datafill for Networked ACD on PRA for table NACDGRP appears in the following table. Only those fields that directly apply to Networked ACD on PRA are shown.

**Datafilling table NACDGRP**

Field	Subfield	Entry	Explanation and action
NTWKGRPS		LCL, REM	network ACD groups. Enter LCL if calls overflow to a local NACD group. Enter REM if calls overflow to a remote NACD group. if you enter LCL for NTWKGRPS, the system presents subfields LCLGRP and PWF.
	LCLGRP	alphanumeric (1–16 characters)	Local NACD group. Enter the name assigned to the local NACD group.
	PWF	0–32,767	Preference weighting factor. Enter the preference weighting factor (PWF) associated with the specified local NACD group. A high PWF indicates a preference to route calls to this NACD group. If you enter REM for NTWKGRPS, the system presents subfields REMGRP and PWF.
	REMGRP	alphanumeric (1–16 characters)	Remote NACD group. Enter the name assigned to the remote NACD group.
	PWF	0–32,767	Preference weighting factor. Enter the PWF associated with the specified remote NACD group. A high PWF indicates a preference to route calls to this NACD group.

**Datafill example for table NACDGRP**

Sample datafill for the Networked ACD on PRA feature package in table NACDGRP appears in the following example. In this example, NACD groups CATALOG and SUPPORT are defined.

## Networked ACD on PRA (end)

---

### MAP example for table NACDGRP

ACDGRP	QTHRESH	WTHRESH	PFW	BESTGRP	SEVRATE	NMIDDLE	TIMEIDLE	NTWKGRPS
OPTIONS								
CATALOG	2	19	100		Y	60	60	60
(LCL SUPPORT 100) \$								
SUPPORT	2	13	100		Y	60	60	60
(LCL CATALOG 100) (REM XSUPPORT 10) \$								
\$								

### Tools for verifying translations

Networked ACD on PRA does not use tools for verifying translations.

### SERVORD

Networked ACD on PRA does not use SERVORD.

---

## PRI Backup D-channel

---

### Ordering code

Functional group ordering code: NI000011

Functionality ordering code: not applicable

### Release applicability

BCS36 and up

### Prerequisites

To operate, PRI Backup D-channel has the following prerequisites:

- NI0 ISDN Base, NI000007
- MDC - MDC Minimum, MDC00001

### Description

This capability provides a backup D-channel to be used when the primary D-channel is out of service. Normally, the primary D-channel is in the inservice (INS) state and the backup D-channel is in the standby (STB) state. In a trouble situation, the system automatically switches the activities on the D-channels (for example, when a carrier or trunk at the switching node at the far end fails, or when there are hardware problems at the DMS-100). When you busy an INS D-channel, a switch of activities to the STB D-channel occurs automatically. Switching manually to backup D-channel can also be done from a MAP (maintenance and administration position) terminal.

### Operation

Datafill the DCHBCKUP subfields in table TRKSGRP to define the backup D-channel. Datafill the DCHNL subfields in table TRKSGRP in the Base Service capability for the primary D-channel. The DCHNL subfields are the same as the DCHBCKUP subfields.

### Translations table flow

PRI Backup D-channel does not affect translations.

### Limitations and restrictions

PRI Backup D-channel has no limitations or restrictions.

### Interactions

PRI Backup D-channel has no functionality interactions.

---

## PRI Backup D-channel (continued)

---

### Activation/deactivation by the end user

PRI Backup D-channel requires no activation or deactivation by the end user.

### Billing

PRI Backup D-channel does not affect billing.

### Station Message Detail Recording

PRI Backup D-channel does not affect Station Message Detail Recording.

### Datafilling office parameters

PRI Backup D-channel does not affect office parameters.

### Datafill sequence

The following table lists the tables that require datafill to implement PRI Backup D-channel. The tables are listed in the order in which they are to be datafilled.

#### Datafill tables required for PRI Backup D-channel

Table	Purpose of table
TRKSGRP	Defines the attributes of the PRI trunk group's D-channels.

### Datafilling table TRKSGRP

The following table shows the datafill specific to PRI Backup D-channel for table TRKSGRP. Only those fields that apply directly to PRI Backup D-channel are shown.

#### Datafilling table TRKSGRP (Sheet 1 of 3)

Field	Subfield	Entry	Description
SGRPKEY		see subfields	Subgroup key. Datafill subfields CLLI and SGRP as one concatenated entry. Separate the two values with a blank. You are not prompted for the subfields individually.
	CLLI	alphanumeric	Trunk group name. From table CLLI, enter the trunk group name to which the subgroup belongs.
	SGRP	0 (zero)	Subgroup. Enter 0 (zero).
SGRPVAR		see subfields	Subgroup variable refinement.

**PRI Backup D-channel** (continued)

Datafilling table TRKSGRP (Sheet 2 of 3)

Field	Subfield	Entry	Description
	DCHBCKUP	see subfields	D-channel backup. Defines the backup D-channel to be used for the interface.  <b>Note:</b> Refer to "Datafilling Base Service" when datafilling the primary D-channel. The subfields must be datafilled twice, once for the primary D-channel and once for the backup D-channel and be in the same tuple. The tuple automatically ends after a backup D-channel is datafilled.
	PMTYPE	DTCI or LTC	Peripheral module type. Enter DTCI or LTC.
	DTCINO	0-511	DTCI number. Enter a number from 0-511 for the DTCI number.  <b>Note:</b> Use when PMTYPE is DTCI.
	LTCNO	0-511	LTC number. Enter a number for the LTCI number.  <b>Note:</b> Use when PMTYPE is LTC
	DTCICKTNO	0-19	DS-1 circuit number. Enter a number from 0-19 for the DS-1 circuit number.  <b>Note:</b> Use when PMTYPE is DTCI.
	LTCCKTNG	0-19	DS-1 circuit number. Enter a number for the DS-1 circuit number. The primary D-channel must be datafilled on a lower DS-1 circuit number than the backup D-channel.
	DTCICKTTS	1-24	D-channel time slot number. Enter a number for the time slot number of the D-channel.  <b>Note:</b> Use when PMTYPE is DTCI.

## PRI Backup D-channel (continued)

### Datafilling table TRKSGRP (Sheet 3 of 3)

Field	Subfield	Entry	Description
	LTCCKTTS	1-24	D-channel time slot number. Enter a number for the time slot of the D-channel.  <b>Note:</b> Use when PMTYPE is LTC
	DCHRATE	56Kor 64K	D-channel rate. Enter 56K or 64K for the data rate of the D-channel.  <b>Note:</b> This field must be compatible with subfield ZLG in table CARRMTC. If subfield ZLG is set to ZCS, DCHRATE must be 56K; if ZLG is B8ZS, DCHRATE must be 64K.
	HDLCTYPE	HDLC	High level datalink type. Enter HDLC for high level data link.

### Datafill example for table TRKSGRP

The following example shows sample datafill for table TRKSGRP.

### MAP display example of table TRKSGRP

SGRPKEY	CARDCODE	SGRPVAR
SL1NTPRI	0 DS1SIG	
ISDN	2 2 87Q931 1 N STAND NETWORK	PT_PT USER N UNEQ
	30 N STRA DTCI 0 0 24 64K HLC	
	(DTCI 0 1 24 64K HDLC)	\$

---

**PRI Backup D-channel (end)**

---

**Error messages for table TRKSGRP**

The following error messages apply to table TRKSGRP.

Error message	Explanation and action
NO OF D-CHANNELS EXCEEDS MAXIMUM LIMIT	The maximum number of D-channels that can be configured in the DTCl is 32. When a new tuple is added to table TRKSGRP, the tuple is accepted in the current number of D-channels configured on the PM is less than the maximum allowed. If it is greater, table LTMAP is checked to determine how many of the D-channels are mapped to an LTID. If the number of mapped D-channels is less than the maximum, the tuple is accepted. If not, this message is displayed.

**Translation verification tools**

PRI Backup D-channel does not use translation verification tools.

**SERVORD**

PRI Backup D-channel does not use SERVORD.

## **PRI: Base MWI Control Using NI-PRI**

---

### **Ordering codes**

Functional group ordering code: NI000052

Functionality ordering code: NA

### **Release applicability**

NA011 and up

NA011 introduced Base Message Waiting Indicator (MWI) Control Using National ISDN Primary Rate Interface (NI-PRI)

### **Requirements**

To operate, PRI: Base MWI Control Using NI-PRI requires AF7569, Non-Call Associated Signalling (NCAS).

### **Description**

Base MWI Control Using NI-PRI provides MWI control that is common to local and remote client users. This activity addresses support of Serving PRI Group as an interface between the DMS-100 switch and the ISDN Message Storage and Retrieval (MSR). Base MWI Control Using NI-PRI functions with pre-NA011 offerings of MWI control for remote client users.

The feature AF7776 allows a host DMS-100 switch to receive and acknowledge MWI control requests using public NI-PRI NCAS connections that are established between the host DMS-100 switch and an ISDN MSR. An NCAS connection allows supplementary services on ISDN class II equipment, such as MWI Control, to communicate with the DMS-100 switch without setting up a circuit switched (B-channel) connection.

### **Operation**

Base MWI Control Using NI-PRI is activated by provisioning the appropriate tables. Users can activate voice mail notification with an access code.

### **Translations table flow**

The list that follows includes the PRI: Base MWI Control Using NI-PRI translations tables:

- Table LTCALLS
- Table LTDATA
- Table SVPRIGRP



---

**PRI: Base MWI Control Using NI-PRI** (continued)

---

- Table MSRTAB
- Table AMAOPTS

The flowchart that follows provides the PRI: Base MWI Control Using NI-PRI translations process.

**Table flow for PRI: Base MWI Control Using NI-PRI**

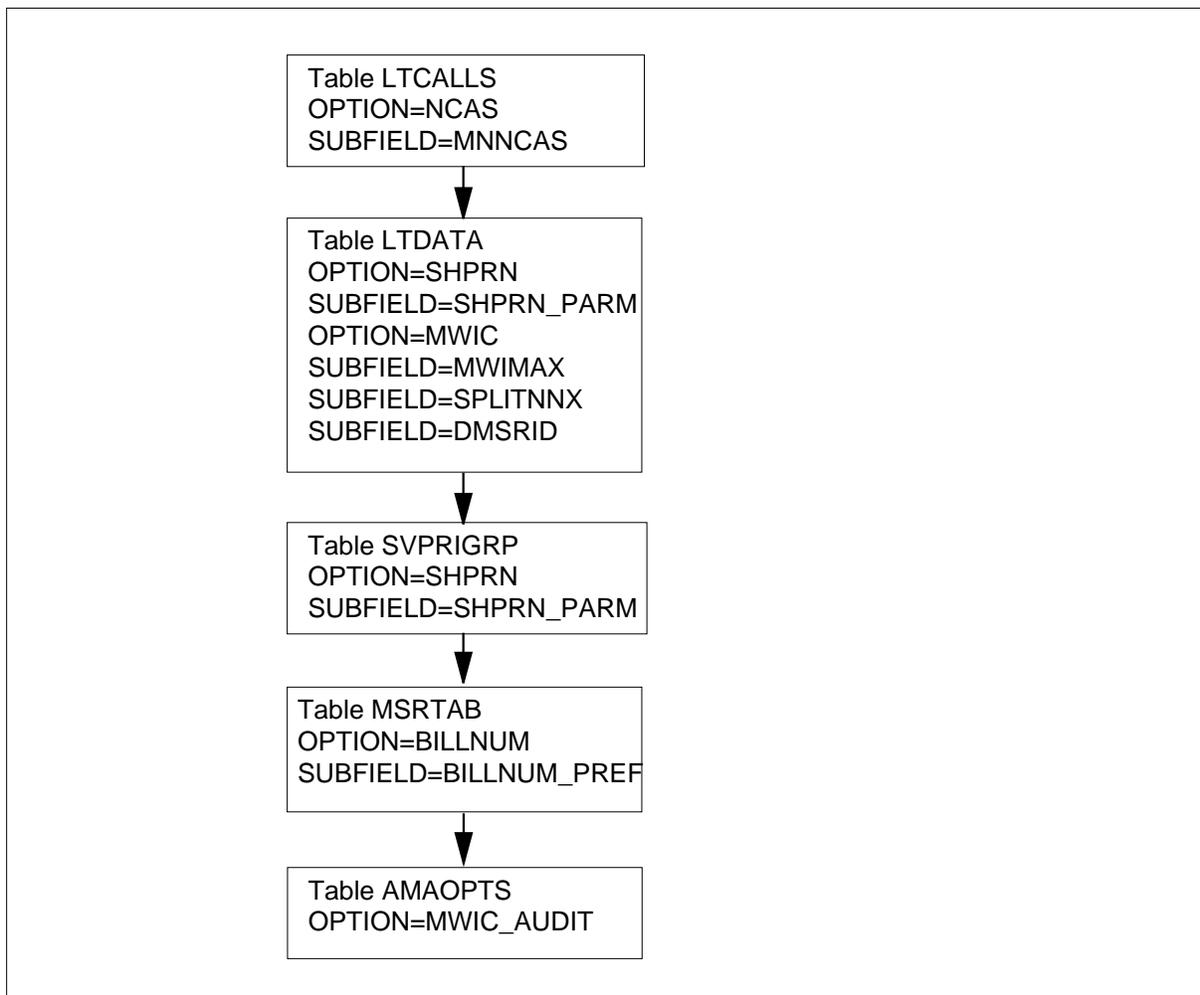

---

**PRI: Base MWI Control Using NI-PRI** (continued)
 

---

The table that follows lists the datafill content used in the flowchart.

**Datafill example for PRI: Base MWI Control Using NI-PRI**

Datafill table	Example data
LTCALLS	ISDN 500 PUB XLALEC 0 (NCAS 5) \$
LTDATA	ISDN 502 SERV SERV Y SCREENED ALWAYS (RNDELV SCREENED) (SHPRN YYYY) ISDN 503 SERV SERV N N ALWAYS ALWAYS(MWIC 500 N9195551234)\$
SVPRIGRP	MSR_SRVGRP1 3 (ISDN 109)(ISDN 110)(ISDN 1111)(SHPRN YYYY)
MSRTAB	6137216050 \$ 8197228907 \$ 7777777777(BILLNUM 6137223001 N)\$
AMA_OPTS	MWIC_AUDIT PERIODIC 980620 0000 24 HRS

**Limitations and restrictions**

The limitations and restrictions that follow apply to PRI: Base MWI Control Using NI-PRI.

**Message services directory number provisioning**

The following limitations and restrictions apply:

- The ``virtual" Message Services Directory Number (DN) of table DNROUTE is not explicitly identified as a Message Services DN. The Message Services DN points to an index of the routing tables, which routes calls to the terminating PRI trunk group.
- The routing tables do not prevent a non-ISDN NI-PRI trunk group from being specified as a terminating interface.
- The PRI Super Trunk Group list does not prevent a non-ISDN NI-PRI trunk group from being specified as a terminating interface.

**MSRID billing number and automatic message accounting generation**

The following limitations and restrictions apply:

- Provisioning  
In table MSRTAB, the maximum number of MSRIDs for an entire switch is limited to 256.
- Automatic Message Accounting/Billing Record  
In the Automatic Message Accounting (AMA) record Daily Aggregate Service Events (DASE) module (code 072), the Interstate count field is used and filled with ``FFFFFF" in accordance with Bellcore AMA Format

---

## PRI: Base MWI Control Using NI-PRI (continued)

---

(BAF) fill procedure. All the counts are populated in the Intrastate count field.

### North American DN system only

-PRI works only in North American loads using North American DN system. This feature will not work with North American loads using Universal DN system.

### Office parameter MAX\_NUM\_PRI\_MWIC\_CONTROL

The office parameter MAX\_NUM\_PRI\_MWIC\_CONTROL can only be in the range of 8-4500. The DMS-100 switch supports up to 4500 outstanding MWI transactions for the entire switch.

Because of the existence of this office parameter for the entire switch, a verify procedure is in place for the office parameter. During the table control change, when the value of this office parameter is being decreased, the input value is verified against the sum of MWIMAX provisioned on all PRI interfaces. If the input value is less than the sum, the change is rejected with the following error message generated:

The value can not be less than the sum of MWIMAX

### Option SHPRN-serving PRI group configuration

The verification process of table SVPRIGRP fails the attempt to add the special handling of presentation restricted numbers (SHPRN) option under the following conditions:

- Option SHPRN added against non-NI-PRI interface

The SHPRN option follows GR-866-CORE requirements and is only applicable to the variant NI-PRI. The Serving PRI Group concept is only supported by the variant NI-PRI. If an attempt is made to provision the SHPRN option in table SVPRIGRP, the verification process generates the following error message:

The SHPRN option and Serving PRI Groups are only supported by the NI-PRI variant only

- Option SHPRN added without CGNDELV and RNDELV

The SHPRN option follows GR-866-CORE requirements and is only valid with the features CGNDELV and RNDELV in table LTDATA. If adding the SHPRN option to a Serving PRI Group with members that do not have

## **PRI: Base MWI Control Using NI-PRI (continued)**

---

CGNDELV and RNDELV provisioned, the verification process generates the following error message:

```
Serving PRI Group members must have CGNDELV and RNDELV
features of table LTDATA to provision SHPRN against a Serving
PRI Group
```

The verification process of table LTDEF fails the attempt to change the variant from NI-PRI to any other variant if the interface is part of a Serving PRI Group. The verification process generates the following error message:

```
PGRPID supported for NI-PRI variant only
```

### **Option SHPRN-single PRI configuration**

The verification process of table LTDATA fails the attempt to add the SHPRN option under the following conditions:

- Option SHPRN added against non-NI-PRI interface

The SHPRN option follows GR-866-CORE requirements and is only applicable to the variant NI-PRI. If adding the SHPRN option to an LTID in table LTDATA that is not defined as NI-PRI, the verification process generates the following error message:

```
SHPRN option is only valid on NI-PRI LTID
```

- Option SHPRN added without RNDELV

Option SHPRN follows GR-866-CORE requirements and is only correct with the option RNDELV in table LTDATA. If adding the SHPRN option to an LTID that does not have RNDELV provisioned, the verification process generates the following error message:

```
The SHPRN option requires RNDELV and CGNDELV set to screened
before adding the SHPRN option
```

The verification process of table LTDEF fails the attempt to change the variant from NI-PRI to any other variant, if the SHPRN option is provisioned against the corresponding LTID in table LTDATA. The verification process generates the following error message:

```
INVALID CHANGE: Delete the SHPRN option entry from table LTDATA
for this interface before changing the PRI variant
```

### **Outstanding PRI MWI control requests on CM SWACT**

Outstanding PRI MWIC control requests are lost on CM switch activity (SWACT).

---

## PRI: Base MWI Control Using NI-PRI (continued)

---

### PRI MWI control processing-call type derivation

The call type (CT) of the client user is not derived from the bearer capability argument that can be provided in the MWI control request. By default, the DMS-100 switch uses CT=VI for basic rate interface (BRI) client users and uses CT=Analog for non-ISDN client users.

### PRI MWI control processing-destination DN is a remote client user-TCAP query with MWI control request

The message transfer part (MTP) priority of the transaction capabilities application part (TCAP) query remains 1, which is not compliant with the GR-866-CORE requirement of 0.

Regardless of the type of number (TON) and the numbering plan identifier (NPI) that the destination DN has in the MWI control request, the DMS-100 switch always encodes TON and NPI in the TCAP query as National (00000000) and ISDN Numbering Plan (0001), respectively.

The DMS-100 switch always encodes the MSRID (00001100) in the TCAP query with TON of National (00000000) and with NPI of ISDN Numbering Plan (0001).

Regardless of whether or not bearer capability is present in the MWI control request, the DMS-100 switch always encodes bearer capability in the TCAP query with the following:

- coding standard of International Telegraph and Telephone Consultative Committee (CCITT) standard
- information transfer capability of SPEECH
- transfer mode of circuit mode
- information transfer rate of 64 kbit/s
- bearer capability multiplier/protocol indicator of CCITT mu-law
- multiplier layer ID of user info layer 1

The DMS-100 switch does not include the Calling Party Number (00000010) in the TCAP query.

The DMS-100 switch does not include the MWI Type Identifier (11010111) in the TCAP query.

The DMS-100 switch does not include the Timestamp Identifier (00010111) in the TCAP query.

## **PRI: Base MWI Control Using NI-PRI** (continued)

---

### **PRI MWI control processing-intersection set of DN**

ITSDN, as described in GR-866-CORE, is not supported.

### **PRI MWI control processing-operational measurements**

The PRIMWIC and MWICTACP operational measurement (OM) groups are maintained on a 30-minute basis, instead of on a special study basis.

### **PRI MWI control processing-optional argument processing**

The MWI Control request can include the following optional arguments:

- **MSRID**

The DMS-100 switch screens the MSRID optional argument in an MWI control request. The DMS-100 switch does not use the MSRID to screen against the authorized MSRID assigned to a client user in order to update the user's MWI.

If the MSRID optional argument is not present in the MWI control request, the DMS-100 switch associates the request with the default MSRID of the NI-PRI.

- **bearer capability**

The DMS-100 switch does not process the bearer capability optional argument in an MWI control request.

- **calling party number**

The DMS-100 switch does not process the calling party number optional argument in an MWI control request.

- **timestamp**

The DMS-100 switch does not process the timestamp optional argument in an MWI control request.

- **MWI type**

The DMS-100 switch does not process the MWI type optional argument in an MWI control request.

### **PRI MWI control provisioning-default MSRID**

The MSRID entered for the default MSRID must exist in table MSRTAB.

If the default MSRID entered is not in table MSRTAB, the verification process of table LTDATA fails the attempt to add or change the tuple and the following error message generates:

```
Default MSRID entered is not in table MSRTAB.
```

---

## PRI: Base MWI Control Using NI-PRI (continued)

---

Table MSRTAB has one limitation. Table MSRTAB does not fail the attempt to delete an MSRID entry even if it is in use by table LTDATA.

### PRI MWI control provisioning-option MWIC

The verification process of table LTDATA fails the attempt to add the MWIC option under the following conditions:

- NCAS option not assigned to NI-PRI LTID

The MWIC option assigned on an NI-PRI LTID in table LTDATA is dependent on the NCAS option assigned on the NI-PRI LTID with PUBLIC service type in table LTCALLS. If the NCAS option does not exist, the verification process generates the following error message:

```
MWIC option is only valid with NCAS option. Ensure that NCAS
option is assigned to the NI PRI LTID with PUBLIC service
type in table LTCALLS
```

- MWIC option being added to non-NI-PRI LTIDs

The MWIC option is delivered according to GR-866-CORE requirements, and thus is only applicable to NI-PRI LTIDs. If the MWIC option is being added to a non-NI-PRI LTID, the verification process generates the following error message:

```
MWIC option is only valid on NI-PRI LTID
```

- MWIMAX exceeds MAX\_NUM\_PRI\_MWIC\_CONTROL

The MWIMAX parameter, or the total MWIMAX of NI-PRI LTIDs assigned with the MWIC option, must not exceed the OFCENG parameter MAX\_NUM\_PRI\_MWIC\_CONTROL. If MWIMAX exceeds parameter MAX\_NUM\_PRI\_MWIC\_CONTROL, the verification process generates the following error message:

```
The total MWIMAX must not exceed OFCENG office parm
MAX_NUM_PRI_MWIC_CONTROL. The current total is
<total_mwimax>. The allowable MWIMAX value must be less than
or equal to <allowable_mwimax>
```

**Note:** Total\_mwimax and allowable\_mwimax are calculated before displaying the error message.

### PRI NCAS processing

The DMS-100 switch does not initiate NCAS connection clearing. Also, the DMS-100 switch does not send Q.931 SETUP NCAS messages to the customer premise equipment (CPE) to initiate an NCAS connection establishment.

## **PRI: Base MWI Control Using NI-PRI (continued)**

---

### **PRI NCAS provisioning**

The verification process of table LTCALLS fails the attempt to remove the NCAS option when assigning options to NI-PRI LTID that are dependent on NCAS, such as the MWIC option in table LTDATA. The process generates the following error message:

```
NCAS option cannot be removed. There is at least one service
depending on NCAS which must be removed first.
```

### **Series completion**

Series completion is not supported by NI-PRI and message services.

## **Interactions**

The paragraphs that follow describe how PRI: Base MWI Control Using NI-PRI interacts with other functionalities.

### **Advanced intelligent network**

The SHPRN feature interacts with advanced intelligence network (AIN) during construction of the terminating NI-PRI SETUP Message. Existing AIN capabilities are not altered by this feature.

The AIN feature can query a signaling control point (SCP) database and change the controlling components of a call. AIN invokes prior to referencing the SHPRN option of a single or serving PRI group. If AIN is involved in the call, the CGN and RN information in the AIN response message will be utilized. The SHPRN option can override the delivery based on the features CGNDELV and RNDELV provisioned against the corresponding NI-PRI trunk.

### **Call forwarding/redirecting numbers**

NI-PRI supports call forwarding or redirecting numbers (RN) by delivering the original and last forwarding (redirecting) numbers. AF6862, Redirecting Numbers, assists the MSR system in locating the appropriate mailbox to leave the message, and in providing an appropriate greeting when answering the call by the MSR.

The SHPRN feature interacts with RN by providing the capability of disregarding the presentation status of the RN and delivering the redirecting numbers to the MSR system. When the SHPRN feature overrides an RN presentation status of "prohibited" and delivers the RN IE to the MSR system, the presentation status is unchanged.



---

## PRI: Base MWI Control Using NI-PRI (continued)

---

### Calling number

The original CGN can be utilized by the MSR system to assist in locating a client user's mailbox to retrieve messages and identify the CGN to the client during message storage. The SHPRN feature provides the capability of disregarding the presentation status of the CGN and delivering the calling number to the MSR system. When the SHPRN feature overrides a CGN presentation status of "prohibited" and delivers the CGN IE to the MSR system, the presentation status is unchanged.

### Circular hunt

Message Services employs the NA010 feature AF7338, Circular Hunting, during route selection to a terminating NI-PRI trunk group. A message services DN associated with a PRI super trunk group can apply the circular hunt selection algorithms CHCL and CHCCL to determine a terminating channel.

The datafill sequence is the same as dictated prerequisite for a single PRI, except when provisioning the valid routing table tuple. A route selector of SG is entered with the chosen selection algorithm and the number of hunting attempts. A valid PRI super trunk group of table SUPERTKG completes the necessary provisioning to map a message service DN to a PRI super trunk group.

### Electronic key telephone set

The EKTS functionality only supports MWI on the primary member of the EKTS group. When audible MWI per DN is assigned and active, the audible indication is only provided for call originations on a primary member basis.

### Two B-channel transfer

The NI-PRI interface connected to an MSR system supports TBCT functionality. A direct call or forwarded call to an MSR system can be one leg of a TBCT. The second leg can be an outgoing call from the MSR system that is in the alerting or unanswered state.

AU2636, Two B-Channel Transfer, allows a user on an NI-PRI trunk to request the DMS-100 switch to connect two independent calls on the controller's interface. If the DMS-100 switch accepts the request, the controller releases itself from the calls and connects the other two users directly.

### Action and deactivation by the user

-PRI does not require activation or deactivation by the user.

---

**PRI: Base MWI Control Using NI-PRI** (continued)
 

---

**Billing**

The figure that follows is an example of an AMA record generated for call code 183.

**Call code 183**

```

HEX ID:AA STRUCTURE CODE:40690C CALL CODE:183C SENSOR
TYPE:036C SENSOR ID:0000000C REC OFFICE TYPE:036C REC
OFFICE ID:0000000C DATE:21208C ORIG NPA:613C ORIG
NUMBER:7223001C CONNECT TIME: 1922219C MODULE CODE:072C
SERVICE CAPABILITY:030 INTRASTATE EVENT COUNT:
00006C INTERSTATE EVENT COUNT: FFFFFFF CHARGING
INDICATOR: 101C IC/INC PREFIX: FFFFFFF BEARER
CAPABILITY:299C MODULE CODE:072C SERVICE CAPABILITY:
031C INTRASTATE EVENT COUNT: 00005C INTERSTATE EVENT
COUNT: FFFFFFF CHARGING INDICATOR: 101C IC/INC PREFIX:
FFFFFFF BEARER CAPABILITY:299C MODULE CODE:000C
  
```

The table that follows provides information for module code 072.

**Module code 072**

Information	Field number	Number of characters
Module code	88	4
ISDN signalling or supplementary service capability identification	414	4
Five-digit number (intrastate count)	803	6
Five-digit number (interstate count)	803	6
Charging indicator	64	4
Interexchange carrier	57	6
Bearer capability/call type	412	4

---

**PRI: Base MWI Control Using NI-PRI (continued)**

---

The table that follows provides information for structure code 0690.

**Structure code 0690**

Information	Field number	Number of characters
Record descriptor word	000	-
Hexadecimal identifier	00	2
Structure code	0	6
Call type	1	4
Sensor type	2	4
Sensor identification	3	8
Recording office type	4	4
Recording office identification	5	8
(Connect) date	6	6
Originating NPA	13	4
Originating number	14	8
(Connect) time	18	8

**Office parameters used by PRI: Base MWI Control Using NI-PRI**

The table that follows lists the office parameters used by PRI: Base MWI Control Using NI-PRI. For additional information about office parameters, refer to the *Office Parameters Reference Manual*.

**Office parameters used by PRI: Base MWI Control Using NI-PRI**

Table name	Parameter name	Explanation and action
MAX_NUM_PRI_MWIC_CONTROL	Maximum number of PRI message waiting indicator control	This office parameter limits the number of outstanding MWI transactions in the DMS switch.

**PRI: Base MWI Control Using NI-PRI** (continued)

**Datafill sequence**

The table that follows lists the tables that require datafill to put PRI: Base MWI Control Using NI-PRI into operation. You must enter data into the tables in this order.

**Datafill requirements for PRI: Base MWI Control Using NI-PRI**

Table	Purpose of table
LTCALLS	Logical Terminal Calls. Stores service-related data, such as translations, that the DMS switch associates with the call type.
LTDATA	Logical Terminal Data. Stores service-related data associated with the logical terminal identifier (LTID), field LTDKEY, which is the key to this table.
SVPRIGRP	Serving PRI Groups. Defines serving PRI groups.
MSRTAB	Message Storage and Retrieval System. Supports feature Update Message Support for MWI (AU2903).
AMA_OPTS	Automatic Message Accounting Options. Controls the activation and scheduling of the recording options for automatic message accounting (AMA).

**Datafill related to PRI: Base MWI Control Using NI-PRI for table LTDATA**

The table that follows provides the datafill related to PRI: Base MWI Control Using NI-PRI for table LTDATA. This table includes only those fields that apply directly to PRI: Base MWI Control Using NI-PRI.

**Datafill related to table LTDATA (Sheet 1 of 2)**

Field	Subfield	Entry	Explanation and action
SHPRN		SHPRN_PARM	Special Handling of Presentation Restricted Numbers. This field affects subfield SHPRN_PARM.
	SHPRN_PARM	NNNN, YYYY, YNNY, NNNY, YNYY, NNY	<p>First letter represents Direct Calls-Calling Party Number.</p> <p>Second letter represents Forwarded Calls-Calling Party Number.</p> <p>Third letter represents Forwarded Calls-Original Number on calls forwarded multiple times.</p> <p>Fourth letter represents Forwarded Calls-Last (or only) Forwarding Number.</p> <p>Default is NNNN.</p>

## PRI: Base MWI Control Using NI-PRI (continued)

### Datafill related to table LTDATA (Sheet 2 of 2)

Field	Subfield	Entry	Explanation and action
MWIC		MWIMAX, SPLITNNX, and DMSRID	Message Waiting Indication Control Option provides the DMS-100 switch with the capability of accepting an MWI control request over an ISDN NI-PRI trunk group. This field affects subfields MWIMAX, SPLITNNX, and DMSRID.
	MWIMAX	8 to 2000	Maximum number of outstanding MWI Control requests that are supported on the NI-PRI. Default is 200.
	SPLITNNX	Y or N	Used only if the host DMS-100 switch shares the client user's code with another switch. This parameter indicates whether to consider the MWI control request received by the host DMS-100 switch as a remote MWI control request. Y indicates a remote request. N indicates a local request. Default is N.
	DMSRID	10 (0, 1, 2, 3, 4, 5, 6, 7, 8, 9)	Default parameter when no MSRID is supplied by the ISDN MSR system. No default value.

### Datafill example for table LTDATA

The figure that follows shows sample datafill for table LTDATA.

#### MAP example for table LTDATA, datatype SERV, option SHPRN

```

LTDKEY    LTDRSLT
-----
ISDN      502 SERV SERV Y SCREENED ALWAYS (RNDELV SCREENED) (SHPRN YYYY)

```

#### MAP example for table LTDATA, datatype SERV, option MWIC

```

LTDKEY
-----
ISDN      503 SERV
SERV N N ALWAYS ALWAYS (MWIC 500 N 9195551234)$
LTDRSLT

```

## PRI: Base MWI Control Using NI-PRI (continued)

### Error messages for table LTDATA

The error messages that follow apply to table LTDATA.

#### Error messages for table LTDATA

Error message	Explanation and action
The SHPRN option is only supported by the NI-PRI variant defined in table LTDEF	An attempt was made to provision SHPRN and the corresponding LTID in table LDEF is not defined as NI-PRI.
INVALID CHANGE: Delete the SHPRN option entry from table LTDATA for this interface before changing the PRI variant	An attempt was made to change the variant from NI-PRI to another variant while the SHPRN option was provisioned.
The RNDELV option of table LTDATA must be provisioned to datafill SHPRN	An attempt was made to provision SHPRN and the RNDELV option was not present.

### Datafill related to PRI: Base MWI Control Using NI-PRI for table LTCALLS

The table that follows provides the datafill related to PRI: Base MWI Control Using NI-PRI for table LTCALLS. This table includes only those fields that apply directly to PRI: Base MWI Control Using NI-PRI.

#### Datafill related to table LTCALLS

Field	Subfield	Entry	Explanation and action
NCAS		MNNCAS	Non-Call-Associated Signaling option. This field affects subfield MNNCAS.
	MNNCAS	1 to 20	The MNNCAS (maximum number of NCAS) of the NCAS option provides the maximum number of NCAS connections established against only a NI-PRI trunk with a PUBLIC service type at any given time. The default value is 1.

### Datafill example for table LTCALLS

The figure that follows shows sample datafill for table LTCALLS.

---

**PRI: Base MWI Control Using NI-PRI (continued)**

---

**MAP display example for table LTCALLS for PRI: Base MWI Control Using NI-PRI for the NCAS option**

LTID		XLARTSEL		OPTIONS
ISDN	500	PUB	XLALEC	0 (NCAS 5) \$

### Datafill related to PRI: Base MWI Control Using NI-PRI for table SVPRIGRP

The table that follows provides the datafill related to PRI: Base MWI Control Using NI-PRI for table SVPRIGRP. This table includes only those fields that apply directly to PRI: Base MWI Control Using NI-PRI.

#### Datafill related to table SVPRIGRP

Field	Subfield	Entry	Explanation and action
SHPRN		SHPRN_PARM	Special Handling of Presentation Restricted Numbers. This field affects subfield SHPRN_PARM.
	SHPRN_PARM	NNNN, YYYY, YNNY, NNNY, YNYY, NNNY	This optional parameter enables the DMS switch to override the delivery of presentation restricted numbers for a servicing PRI group interface. Under specific conditions, calls offered to a terminating servicing PRI group can override the delivery restrictions and can provide an MSR system and/or intelligent peripheral (IP) with the calling number (CGN) and/or the redirected number (RN). The presentation status of the information elements (IE) remains unchanged. The DMS switch delivers the CGN and RN IE to an MSR system or IP with an unaltered presentation status. The default value is NNNN.

#### Datafill example for table SVPRIGRP

The figure that follows shows sample datafill for table SVPRIGRP.

**PRI: Base MWI Control Using NI-PRI** (continued)

**MAP display example for table SVPRIGRP for PRI: Base MWI Control Using NI-PRI with the SHPRN option**

```

PGRPID                NUMMEM    MEMBERS
-----
MSR_SRVGRP1 3 (ISDN 109) (ISDN 110) (ISDN 111)
(SHPRN YYYY)
    
```

*Note:* CGNDELV and RNDELV of table LTDATA must be set to screened for SHPRN to be provisioned.

**Datafill related to PRI: Base MWI Control Using NI-PRI for table MSRTAB**

The table that follows provides the datafill related to PRI: Base MWI Control Using NI-PRI for table MSRTAB. This table includes only those fields that apply directly to PRI: Base MWI Control Using NI-PRI.

**Datafill related to table MSRTAB**

Field	Subfield	Entry	Explanation and action
MSRID		10-digit string(0,1,2,3,4,5,6,7,8,9)	Message storage and retrieval system identification. This field affects subfields BILLNUM and BILLNUM_PREF.
	BILLNUM	10-digit string(0,1,2,3,4,5,6,7,8,9)	The billnum option associates a billing number with an MSRID.
	BILLNUM_PREF	Y or N	Indicates whether to generate billing or not if activation/deactivation count is equal to zero. Default value of Y.

**Datafill example for table MSRTAB**

The figure that follows shows sample datafill for table MSRTAB.



---

**PRI: Base MWI Control Using NI-PRI (continued)**

---

**MAP display example for table MSRTAB**

MSRID	OPTLIST
6137216050	\$
8197228907	\$
7777777777	(BILLNUM 6137223001 Y) \$

**Datafill related to PRI: Base MWI Control Using NI-PRI for table AMAOPTS**

The table that follows provides the datafill related to PRI: Base MWI Control Using NI-PRI for table AMAOPTS. This table includes only those fields that apply directly to PRI: Base MWI Control Using NI-PRI.

**Datafill related to table AMAOPTS**

Field	Subfield	Entry	Explanation and action
OPTION		MWIC_AUDIT	Recording options for Automatic Message Accounting (AMA). This field affects subfield MWIC_AUDIT.
	MWIC_AUDIT	PERIODIC yymmdd 0000 24 HRS	This option provides the DMS-100 switch the ability to generate daily AMA records of aggregate counts of successful MWI control activations and deactivations on an MSRID basis. The MWIC_AUDIT option works in conjunction with the BILLNUM option in table MSRTAB. MWIC_AUDIT schedules the audit to capture the metrics of the new BILLNUM option.

**Datafill example for table AMAOPTS**

The figure that follows shows sample datafill for table AMAOPTS.

## **PRI: Base MWI Control Using NI-PRI (end)**

---

### **MAP example for table AMAOPTS**

```
OPTION          SCHEDULE
-----
MWIC_AUDIT     PERIODIC 980620 0000 24 HRS
```

### **Translation verification tools**

The NCAS portion of this feature does not use translation verification to confirm translations.

### **SERVORD**

-PRI does not use the Service Order System (SERVORD).

---

## PRI Base Service

---

### Ordering code

Functionality group ordering codes: NI000011, NI000012, NI000022

Functionality ordering code: Not applicable

### Release applicability

BCS36 and up

### Prerequisites

To operate, PRI Base Service has the following prerequisites:

- NI0 ISDN Base, NI000007
- MDC - MDC Minimum, MDC00001

### Description

The PRI Base Service capability provides the base features of ISDN PRI voice and data services. This capability establishes a PRI interface from the DMS-100 switch to another switching node at the far end. As shown in the following figure, the interface is implemented on DS-1 links between the two nodes.

#### PRI Base Service

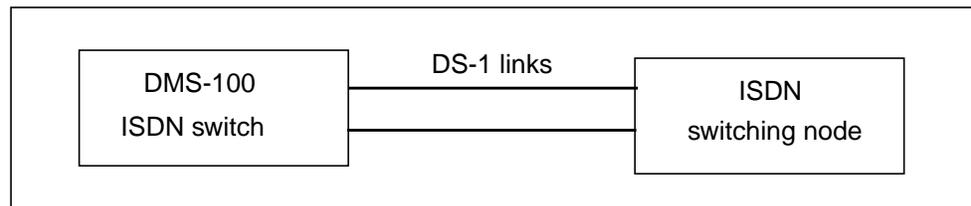

You can use PRI to connect the DMS-100 switch to the following Nortel products:

- DMS-100 switch
- DMS-250 switch
- Meridian 1 Options 11–81 (SL-1 system) private branch exchange (PBX)
- Meridian 1 Options 111–211 (SL-100 system) PBX

You can also connect the DMS-100 switch to a number of switches that vendors other than Nortel produce.

## **PRI Base Service** (continued)

---

ISDN uses time-division multiplexed digital channels to carry information. The ISDN PRI interface consists of B-channels and D-channels. The B-channels carry circuit-switched voice or data between the DMS-100 switch and the switching node at the far end. The D-channels carry the call control messages for the B-channels.

You can implement a PRI interface on a number of digital signal level 1 (DS-1) links. Each B-channel and D-channel occupies one time slot on a DS-1.

Each DS-1 link can handle 24 B-channels or 23 B-channel and one D-channel. One D-channel can support up to 479 B-channels. A PRI interface can consist of 479 B-channels and one D-channel over a maximum of 20 DS-1 links. However, for traffic considerations and protection against equipment failure, Nortel recommends a lower D-channel-to-B-channel ratio. Typical installations have one D-channel for every one or two DS-1 links (a ratio of one D-channel for 23 or 47 B-channels).

Refer to the Dialable Wideband Service Services Guide for information about Dialable Wideband Service (DWS) and H-channels.

The PRI interface supports 15-Digit International Dialing. 15-Digit International Dialing is a regulatory requirement that expands the maximum number of digits that a customer can dial during an international call from 12 to 15. The cutover from the current 12-Digit International Numbering Plan to the 15-Digit International Numbering Plan is at 2359 coordinated universal time on December 31, 1996.

For more information about the 15-Digit International Dialing, refer to "15-Digit International Dialing" (Functional group ordering code LOC00004) in the LOC translations section in this document.

## **Operation**

The datafill for the Base Service capability defines the hardware, trunks, and logical terminals (LT) involved in the PRI interface.

### **PRI hardware**

The DS-1 links between the switching nodes terminate in the DMS-100 switch at the ISDN digital trunk controller (DTCI) or ISDN line trunk controller (LTCI) peripheral module.

Each DTCI supports a maximum of 20 links on 10 DS-1 cards. Typically, one D-channel is assigned for every two DS-1 links. All the DS-1 B-channels serviced by a D-channel must be located on the same DTCI or LTCI.

---

## PRI Base Service (continued)

---

Information relating to the DTCl and LTCl is datafilled in tables LTCINV and LTCPSINV.

The signaling information carried in the D-channel is processed in the ISDN signaling preprocessor (ISP) card in the DTCl. The ISP card can support a maximum of 32 D-channels in the DTCl. The ISP card is located in slot 16 and must be datafilled in table LTCINV.

### PRI trunks

In PRI terms, a trunk is a B- or D-channel. A trunk group is the collection of B- and D-channels forming the PRI interface. You can implement the trunk group across a number of DS-1 links. PRI trunk groups are defined in tables CLLI, PADDATA, TRKGRP, and CARRMTC.

Unlike other trunk group types, a PRI trunk group has no subgroups as such, but the trunk's D-channel is defined in table TRKSGRP. (There must be one D-channel defined for each trunk group.) The B-channels, also known as trunk group members, are defined in table TRKMEM.

### Logical terminals

In ISDN applications, the concept of the LT clarifies the situation in which more than one physical terminal can associate with a single line card.

In PRI application, the LT is actually the switching node at the far end. By extension, the PRI interface or trunk group is the equivalent of a LT. As each LT has an identifier and belongs to a LT group, the PRI trunk group is datafilled with these attributes in tables LTGRP, LTDEF, and LTMAP.

### Translations table flow

The PRI Base Service translation process is shown in the following flowchart. Most of the Base Service tables are information tables and do not affect the PRI translation process. The trunking tables (TRKGRP, TRKSGRP, and TRKMEM) are included in the call processing data flow description in the PRI Call Routing and Bearer Capability Routing capabilities.

## PRI Base Service (continued)

Table flow for PRI Base Service

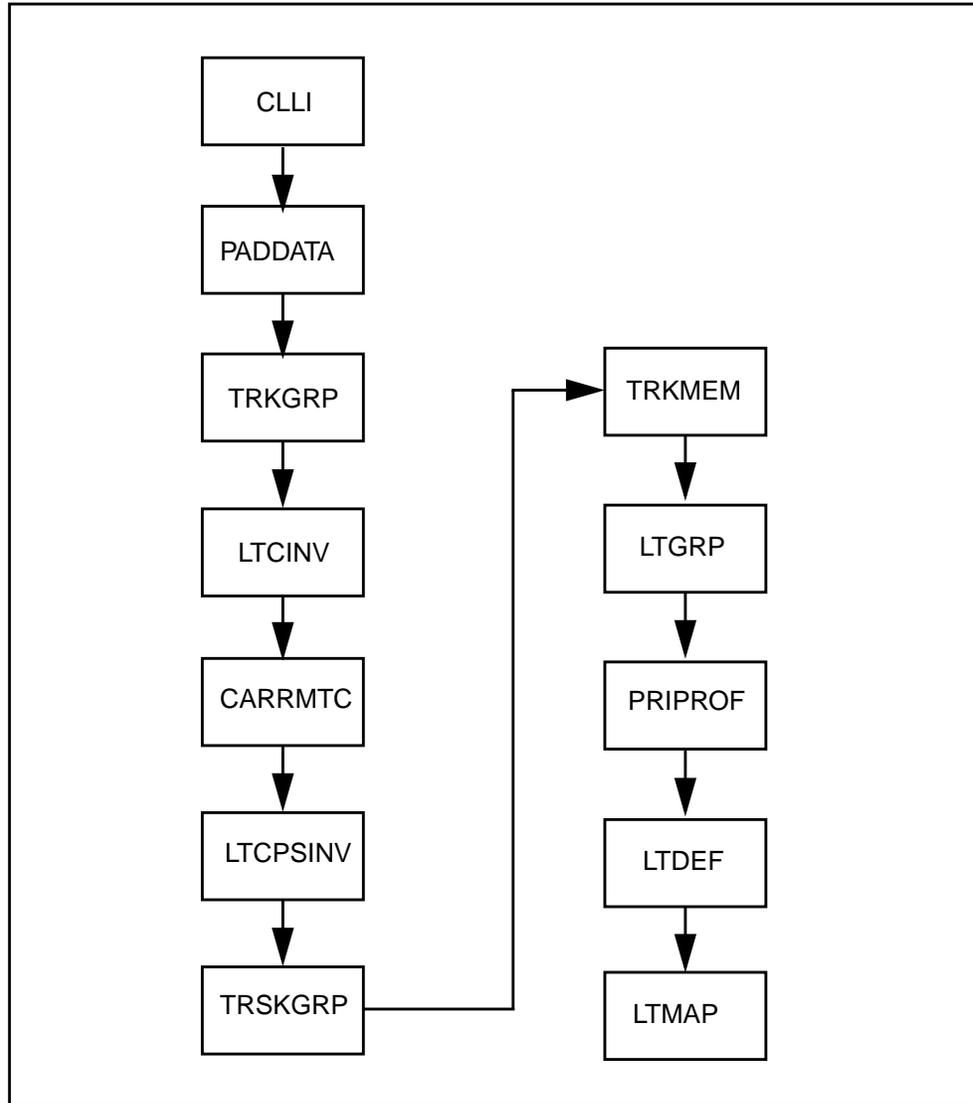

### Limitations and restrictions

The following limitations and restrictions apply to PRI Base Service:

Table PRIPROF can have a maximum of 255 profiles datafilled in field PROFNAME and subfields VARIANT and ISSUE. The maximum number of variants is 15. Each variants can have a maximum of 15 issues.

When you make changes to subfields VARIANT, ISSUE, or PROFNAME in table LTDEF, the D-channel associated with the LTID must be installation

---

**PRI Base Service** (continued)

---

busy (INB). The LTID must be mapped to a D-channel that is datafilled as a CLLI in table TRKSGRP. Changes take effect when the changed tuple is accepted.

A tuple change in table PRIPROF only becomes effective by unmapping and mapping the entry for the associated LTID in table LTMAP. This includes changing the variant, issues, or function switches in the profile.

***The following steps are for changing a profile:***

- 1 A tuple can only be deleted from table PRIPROF when all references to the profile name have been removed from table TLDEF. Add a new profile name to table PRIPROF reflecting the required modifications.
- 2 Change the D-channel state to INB.
- 3 Delete the associated entry in table LTMAP.
- 4 Change all references to the old profile name in table LTDEF to the new profile name.
- 5 Replace the associated entry in table LTMAP.
- 6 Delete the old profile name from table PRIPROF.
- 7 Return the D-channel to service.

A tuple can only be deleted from table PRIPROF when all references to the profile name have been removed from table LTDEF.

***The following steps are for changing a profile:***

- 1 Change the D-channel state to INB.
- 2 Delete the associated entry in table LTMAP.
- 3 Delete all references to the old profile name from table LTDEF, or change the old profile name to a valid profile name for the variant and issue.
- 4 Replace the associated entry in table LTMAP.
- 5 Delete the old profile name from table PRIPROF.
- 6 Return the D-channel to service.

**Interactions**

PRI Base Service has no functionality interactions.

**Activation/deactivation by the end user**

PRI Base Service requires no activation or deactivation by the end user.

**Billing**

PRI Base Service does not affect billing.

---

## PRI Base Service (continued)

---

### Station Message Detail Recording

PRI Base Service does not affect Station Message Detail Recording (SMDR).

### Datafilling office parameters

PRI Base Service does not affect office parameters.

### Datafill sequence

The following table lists the tables that require datafill to implement PRI Base Service. The tables are listed in the order in which they are to be datafilled.

#### Datafill tables required for PRI Base Service

Table	Purpose of table
CLLI	Defines the PRI trunk group name.
PADDATA	Defines the loss and level plan for PRI.
TRKGRP	Defines the data associated with each trunk group as a whole.
LTCINV	Contains the inventory of DTCl peripheral modules (PM).
CARRMTC	Contains the attributes of the DS-1 links between the DTCl and the switching node at the far end.
LTCPSINV	Contains the P-side link assignments for the DTCl.
TRKSGRP	Defines the attributes of the PRI trunk group's D-channel.
TRKMEM	Defines the attributes of the B-channels in each trunk group.
LTGRP	Defines the LT group to which the PRI trunk group belongs.
PRIPROF	Establishes a PRI profile to be used for each interface.
LTDEF	Specifies a LTID and access privileges for the PRI trunk group.
LTMAP	Associates the PRI trunk's LTID with the trunk group CLLI.

### Datafilling table CLLI

Table CLLI is datafilled to define the name of the trunk group.



---

**PRI Base Service** (continued)

---

The following table shows the datafill specific to PRI Base Service for table CLLI. Only those fields that apply directly to PRI Base Service are shown. For a description of the other fields, refer to the data schema section of this document.

**Datafilling table CLLI**

Field	Subfield or refinement	Entry	Explanation and action
CLLI		alphanumeric (up to 16 characters)	Trunk group name. Enter the name of the trunk group.
ADNUM		numeric (50 to 8191)	Administration number. Enter a numeric value.  <b>Note:</b> The number must be less than the size of table CLLI defined in table DATASIZE.
TRKGRSIZ		numeric (0 to 2047)	Trunk group size. Enter the number that represents the total number of B-channels in the PRI trunk group.
ADMININF		alphanumeric (up to 32 characters)	Administration information. Enter text to describe the CLLI.

**Datafill example for table CLLI**

The following example shows sample datafill for table CLLI. This example illustrates a 47B+D configuration.

**MAP display example for table LTDATA**

CLLI	ADNUM	TRKGRSIZ	ADMININF
SL1NTPRI	172	47	PRA_TRUNK_TO_SL1_PBX

**PRI Base Service** (continued)

**Error message for table CLLI**

The following error messages apply to table CLLI.

**Error message for table CLLI**

Error message	Explanation and action
ADNUM greater than 50 must be used if CLLI is not a PSEUDOCLLI.	A value less than or equal to 50 has been entered in field ADNUM for a CLLI that is not a shortened CLLI. Enter a value of greater than 50 in field ADNUM.

**Datafilling table PADDATA**

Table PADDATA contains the loss and level plan for the DMS-100 switch, ensuring acceptable voice quality for calls over the interface. The table has an entry for each destination trunk group accessible by the interface.

The following table shows the datafill specific to PRI Base Service for table PADDATA. Only those fields that apply directly to PRI Base Service are shown.

**Datafilling table PADDATA (Sheet 1 of 2)**

Field	Subfield or refinement	Entry	Explanation and action
PADKEY		see subfields	PADDATA key. Datafill subfields PADGRP1 and PADGRP2 as one concatenated entry. Separate the two values with a blank. You are not prompted for the subfields individually.
	PADGRP1	alphanumeric (up to 5 characters)	PAD group 1. Enter a name that defines the originating PAD group.
	PADGRP2	alphanumeric (up to 5 characters)	PAD group 2. Enter a name that defines the destination PAD group.

**PRI Base Service** (continued)**Datafilling table PADDATA (Sheet 2 of 2)**

<b>Field</b>	<b>Subfield or refinement</b>	<b>Entry</b>	<b>Explanation and action</b>
PAD1TO2		alphanumeric (up to 3 characters)	PAD group 1 to PAD group 2. For the transmit PAD, enter one of the following values: <ul style="list-style-type: none"> <li>• 0 (zero)</li> <li>• 0L to 14L for loss</li> <li>• 0G to 7G for gain</li> </ul>
PAD2TO1		alphanumeric (up to 3 characters)	PAD group 2 to PAD group 1. For the transmit PAD, enter one of the following values: <ul style="list-style-type: none"> <li>• 0 (zero)</li> <li>• 0L to 14L for loss</li> <li>• 0G to 7G for gain</li> </ul>

**Datafill example for table PADATA**

The following example shows sample datafill for table PADDATA.

**PRI Base Service** (continued)

**MAP display example for table PADDATA**

	PADKEY	PAD1T02	PAD2T01
PRAC	UNBAL	3L	0
PRAC	STD LN	3L	0
PRAC	LRLM	3L	0
PRAC	PPHON	0	0
PRAC	DAVLN	6L	0
PRAC	IAO	3L	0
PRAC	LCO	3L	0
PRAC	ELO	0	0
PRAC	ETLS	0	0
PRAC	ETLL	0	0
PRAC	TLA	0	0
PRAC	TLD	3G	0
PRAC	CONF	2G	0
PRAC	CPOS	0	0
PRAC	TPOS	0	0
PRAC	BRA	0	0
PRAC	PRAC	0	0
PRAC	RSC	3L	0
PRAC	ITT	0	0
PRAC	DID	0	0
PRAC	ATT	3L	0
PRAC	DTT	0	0
PRAC	SHFX	0	0
PRAC	LHFX	0	0

**Datafilling table TRKGRP**

Table TRKGRP contains information that applies to the trunk group as a whole, such as the B-channel selection sequence, the LTID of the trunk group, and the billing directory number (DN).

The following table shows the datafill specific to PRI Base Service for table TRKGRP. Only those fields that apply directly to PRI Base Service are shown.

**Datafilling table TRKGRP (Sheet 1 of 5)**

Field	Subfield or refinement	Entry	Explanation and action
GRPKEY		see subfield	Group key. This field consists of subfield CLLI.
ADNUM	CLLI	alphanumeric (up to 16 characters)	Common language location identifier. From table CLLI, enter the trunk group name.

**PRI Base Service** (continued)

Datafilling table TRKGRP (Sheet 2 of 5)

Field	Subfield or refinement	Entry	Explanation and action
GRPINFO		see subfields	Group information. This subfield consists of GRPTYP, TRAFSNO, PADGRP, NCCLS, SELSEQ, BILLDN, and LTID.
	GRPTYP	PRA, IBNTO, IBNTI, or IBNT2	Group type. Define the trunk type by entering one of the following values: <ul style="list-style-type: none"> <li>• PRA for primary rate interface</li> <li>• IBNTO for MDC outgoing</li> <li>• IBNTI for MDC incoming</li> <li>• IBNT2 for MDC two-way</li> </ul>
	TRAFSNO	numeric (0 to 127)	Traffic signaling number. Enter a numeric value. Enter 0 (zero) when the traffic signalling number is not required.
	PADGRP	alphanumeric (up to 5 characters)	PAD group. Enter the name of the originating PAD group from table PADDATA (subfield PADGRP1).

**PRI Base Service** (continued)

## Datafilling table TRKGRP (Sheet 3 of 5)

Field	Subfield or refinement	Entry	Explanation and action
	NCCLS	NCBN, NCID, NCIM, NCIT, NCLT, NCOF, NCON, NCOT, NCRT, NCTC, or NOSC	<p>Operational measurement (OM) no circuit class. The OM no circuit class, associated with the trunk group, indicates which OM register is incremented when generalized no circuit (GNCT) treatment occurs. Enter one of the following values:</p> <ul style="list-style-type: none"> <li>• NCBN for no circuit business network (OM register OFZNCBN)</li> <li>• NCID for no circuit inward dial (OM register OFZNCID)</li> <li>• NCIM for no circuit intermachine (OM register OFZNCIM)</li> <li>• NCIT for no circuit intertoll (OM register OFZNCIT)</li> <li>• NCLT for no circuit local tandem (OM register OFZNCLT)</li> <li>• NCOF for no circuit offnet trunk (OM register OFZNCOF)</li> <li>• NCON for no circuit onnet trunk (OM register OFZNCON)</li> <li>• NCOT for no circuit other trunk (OM register OFZNCOT)</li> <li>• NCRT for no circuit (OM register OFZNCRT)</li> <li>• NCTC for no circuit toll completing (OM register OFZNCTC)</li> <li>• NOSC for no service circuit (OM register OFZNOSC)</li> </ul>
	SELSEQ	ASEQ, DSEQ, MIDL, LIDL, CWCTH, or CCWCTH	<p>Selection sequence. This field determines the sequence in which trunks are selected within the trunk group. It is used to reduce B-channel glare by coordinating the selection of channels between the DMS-100 and the switching node at the far end.</p>

---

**PRI Base Service** (continued)

---

**Datafilling table TRKGRP (Sheet 4 of 5)**

Field	Subfield or refinement	Entry	Explanation and action
			<p>Three sets of two corresponding values for SELSEQ define the three types of trunk selection: ascending/descending, most idle/least idle, and clockwise/counter-clockwise circular hunting. Each set includes two values so that opposite ends of the PRI trunk group can be datafilled with opposite SELSEQ field values.</p> <p>Enter ASEQ (ascending sequence) or DSEQ (descending sequence) to specify the ascending/descending selection sequence in which the switch searches for a free B-channel.</p> <p>Enter MIDL (most idle) or LIDL (least idle) to choose the most idle or least idle method of trunk selection.</p> <p>Enter CWCTH (clockwise circular trunk hunting) or CCWCTH (counter-clockwise circular trunk hunting) to specify the circular trunk hunting selection sequence.</p> <p><b>Note:</b> Use when subfield GRPTYP is PRA.</p> <p>To change the field SELSEQ value after the trunk group has been datafilled, you must delete the trunk group and then add it again.</p>

**PRI Base Service** (continued)

**Datafilling table TRKGRP (Sheet 5 of 5)**

Field	Subfield or refinement	Entry	Explanation and action
	BILLDN	numeric (up to 11 digits) or N	<p>Billing director number. Datafill this field as described below:</p> <ul style="list-style-type: none"> <li>• Enter the DN (up to 11 digits) to which all calls are billed, regardless of the calling party number, when the calling number is a billing DN.</li> <li>• Enter N when the calling number is a billing DN.</li> </ul>
	LTID	\$	<p>Logical terminal identifier. Enter a \$ to satisfy the table editor. This field is automatically updated by the system after you datafill the corresponding entry in table LTMAP.</p> <p><b>Note:</b> In the datafill example, the tuple is shown after table TRKGRP has been updated automatically with the LTID from table LTMAP.</p>

**Datafill example for table TRKGRP**

The following example shows sample datafill for table TRKGRP.

**MAP display example for table TRKGRP**

GRPKEY	GRPINFO
SL1NTPRI	PRA 0 PRAC NCIT ASEQ N (ISDN 1008)\$

**Datafilling table LTCINV**

Table TRKGRP is the inventory of DTCI PMs in the DMS-100 switch. It identifies the location of the hardware, the load and executive programs required, and the C-side DS30 links to the network modules. The basic PM information is datafilled by Nortel when they build the software load. However, for each DTCI used by the PRI trunk group, table LTCINV must be datafilled with the terminal type (PRAB) and with the two optional cards required for PRI operation, RAM6X69 and ISP16.



**PRI Base Service** (continued)

The following table shows the datafill specific to PRI Base Service for table LTCINV. Only those fields that apply directly to PRI Base Service are shown.

**Datafilling table LTCINV**

<b>Field</b>	<b>Subfield or refinement</b>	<b>Entry</b>	<b>Explanation and action</b>
LTCNAME		see subfield	Line trunk controller name. Datafill subfields XPMTYPE and XPMNO as one concatenated entry. Separate the two values with a blank. You are not prompted for the subfields individually.
	XPMTYPE	DTCI or LTC	Extended peripheral module type. Enter DTCI or LTC.
	XPMNO	numeric (0 to 255)	Extended peripheral module number. Enter a numeric value.
FRTYPE		DTE	Frame type. Enter DTE.
EXECTAB		see subfields	Executive table. Datafill subfields TRMTYPE and EXEC as one concatenated entry. Separate the two values with a blank. You are not prompted for the subfields individually. Enter a \$ to end the field.
	TRMTYPE	PRAB	Terminal type. Enter PRAB to indicate that the type of terminal supported on the peripheral module supports PRI B-channels.
EXECTAB	EXEC	DTCEX	Executive program. Enter DTCEX.
OPTCARD		RAM6X69, or ISP16, or \$	Optional card. Enter RAM6C69 for downloadable tones or enter ISP16. Enter a \$ to end the field.

**Datafill example for table LTCINV**

The following example shows sample datafill for table LTCINV.

**PRI Base Service** (continued)

**MAP display example for table LTCINV**

LTCNAME	FRTYPE	FRNO	SHPOS	FLOOR	ROW	FRPOS	EQPEC	LOAD
							EXECTAB	
							CSLNKTAB	
							OPTCARD	
TONESET		PECS6X45						
		E2LOAD						
PEC6X40							OPTATTR	
<hr/>								
DTCI	1	DTE	1	18	0	G	0	6X02AA DT36
								( PRAB DTCEX)\$
	(0 31 3 0)		(0 31 3 1)		(0 31 3 2)		(0 31 3 3)	
	(0 31 3 4)		(0 31 3 5)		(0 31 3 6)		(0 31 3 7)	
	(0 31 3 8)		(0 31 3 9)		(0 31 3 10)		(0 31 3 11)	
	(0 31 3 12)		(0 31 3 13)		(0 31 3 14)		(0 31 3 15)\$	
							(RAM6X69 )	( ISP16)\$
NORTHAM		6X45BA	6X45BA					
			NILLOAD					
6X40CA								\$

**Error message for table LTCINV**

The following error messages apply to table LTCINV

**Error message for table LTCINV**

Error message	Explanation and action
THE ISP16 OPTCARD CANNOT BE REMOVED FROM THIS ISDN PERIPHERAL.	The ISP16 card is required in the DTCL. Datafill field OPTCARD with ISP16.
AN E2LOAD IS NOT REQUIRED FOR 6X45BA PROCESSORS. E2LOAD HAS BEEN DEFAULTED TO NILLOAD.	The E2LOAD is not required for the DTCL. The E2LOAD field is automatically datafilled with NILLOAD.
EQPEC 6X02P3 MUST HAVE OPTCARD RAM6X69.	The RAM6X69 card is required in the DTCL. Datafill field OPTCARD with RAM6X69.

**Datafilling table CARRMTC**

Table CARRMTC contains information describing the DS-1 links between the DMS-100 and the switching node at the far end. This table defines the line

---

**PRI Base Service** (continued)

---

coding and frame format used in the DS-1 link and provides maintenance control information for the link. The DS-1 card used for PRI is NT6X50AB, which uses standard frame format and supports either B8ZS or ZCS line coding techniques. The B8ZS line coding technique allows the transfer of 64-kbit/s clear information, whereas ZCS allows a maximum transfer capability of 56-kbit/s restricted information. Most carrier systems run at 64 kbit/s, but occasionally the DMS-100 is connected to carrier equipment that operates at 56 kbit/s, which requires the DMS-100 D- and B-channels to run at 56 kbit/s.

An entry for the switch is datafilled with default values at load-build time. The default values, for the fields listed below, must be exchanged for PRI Base Service. To change the default value, create a new tuple in CARRMTC and change the appropriate fields as required.

The following table shows the datafill specific to PRI Base Service for table CARRMTC. Only those fields that apply directly to PRI Base Service are shown.

**Datafilling table CARRMTC (Sheet 1 of 3)**

Field	Subfield or refinement	Entry	Explanation and action
CSPMTYPE		DTCI or LTC	Carrier peripheral module type. Enter DTCI or LTC.
TMPLTNM		alphanumeric (up to 16 characters)	Template name. Enter the template name for DTCI or LTC. The default template name is DEFAULT.  <b>Note:</b> This name is used in subfield CARRIDX in table LTCPSINV.
RTSML		255	Return-to-service maintenance limit. Enter 255.
RTSOL		255	Return-to-service out-of-service limit. Enter 255.

## PRI Base Service (continued)

### Datafilling table CARRMTC (Sheet 2 of 3)

Field	Subfield or refinement	Entry	Explanation and action
ATTR		see subfields	Attributes. This field consists of subfields SELECTOR, CARD, VOICELAW, FF ZLG, BERB, DLK, IAT, LCGAST, LCGACL, RCGAST, RCGACL, AISST, AISCL, BEROL, BERML, ES, SES, FRAMEML, FRAMEOL, SLIPML, and SLIPOL.  <b>Note:</b> This field must be compatible with subfield DCHRATE in table TRKSGRP. There are no error messages for incorrect entries.
	SELECTOR	DS1	Selector. Enter DS1.
	CARD	NT6X50AB	Card name. Enter NT6X50AB
	VOICELAW	MU_LAW or A_LAW	Voice law. MU_LAW or A_LAW
	FF	ESF or SF	Frame format. Enter one of the following values: <ul style="list-style-type: none"> <li>• ESF for extended superframe</li> <li>• SF for superframe</li> </ul>
	ZLG	B8ZS or ZCS	Line coding scheme. Enter one of the following values: <ul style="list-style-type: none"> <li>• B8ZS to allow for the capability of 64-kbit/s clear communication</li> <li>• ZCS for 56-kbit/s restricted information</li> </ul> <b>Note:</b> There are no error messages for incorrect entries.
	BERB	BPV or CRC	Bit error rate base. Enter one of the following values: <ul style="list-style-type: none"> <li>• BPV when field FF is SF</li> <li>• CRC when field FF is ESF</li> </ul> <b>Note:</b> There are no error messages for incorrect entries.
	DLK	NILDL	Data link. Enter NILDL.

**PRI Base Service** (continued)

Datafilling table CARRMTC (Sheet 3 of 3)

Field	Subfield or refinement	Entry	Explanation and action
	IAT	Y or N	Inhibit alarm transmit. Enter Y or N to inhibit the alarm.
	LCGAST	numeric (1 to 9999)	Local carrier alarm stop threshold. Enter a numeric value. Normally 250.
	LCGACL	numeric (1 to 9999)	Local carrier group alarm clear threshold. Enter a numeric value. Normally 1000.
	RCGAST	numeric (1 to 9999)	Remote carrier alarm stop threshold. Enter a numeric value. Normally 50.
	RCGACL	numeric (1 to 9999)	Remote carrier alarm clear threshold. Enter a numeric value. Normally 50.
	AISST	numeric (1 to 9999)	Alarm indication selection stop threshold. Enter a numeric value. Normally 150.
	AISCL	numeric (1 to 9999)	Alarm indication selection clear threshold. Enter a numeric value. Normally 1000.
	BEROL	3	Bit error rate out-of-service limit. Enter 3.
	BERML	6	Bit error rate maintenance limit. Enter 6.
	ES	864	Errored seconds threshold. Enter 864.
	SES	numeric (1 to 9999)	Sever error record threshold. Enter a numeric value. Normally 100.
	FRAMEML	17	Frame loss maintenance limit. Enter 17.
	FRAMEOL	511	Frame loss out-of-service limit. Enter 511.
	SLIPML	4	Slip count maintenance limit. Enter 4.
	SLIPOL	255	Slip count out-of-service limit. Enter 255.

**Datafill example for table CARRMTC**

The following example shows sample datafill for table CARRMTC.

## PRI Base Service (continued)

### MAP display example for table CARRMTC

CSPMTYPE	TMPLTNM	RTSML	RTSOL	ATTR
DTCI	PRI64C	255	255	DS1 NT6X50AB MU_LAW ESF B8ZS CRC NILDL N 250 1000 50 50 150 1000 3 6 864 100 17 511 4 255

### Datafilling table LTCPSINV

Table LTCPSINV lists the P-side link assignments for the DTCI, defining the DS-1 links to the switching node at the far end. The table contains an entry for each DTCI that defines all the PM P-side links. When a PM is datafilled in table LTCINV, the entry in table LTCPSINV is automatically created with the PSLINK number followed by NILTYPE. NILTYPE reflects the correct values for the remaining subfields.

The following table shows the datafill specific to PRI Base Service for table LTCPSINV. Only those fields that apply directly to PRI Base Service are shown.

#### Datafilling table LTCPSINV (Sheet 1 of 2)

Field	Subfield or refinement	Entry	Explanation and action
LTCNAME		see subfields	Line trunk controller name. Datafill subfields XPMTYPE and XPMNO as one concatenated entry. Separate the two values with a blank. You are not prompted for the subfields individually.
	XPMTYPE	DTCI or LTC	Extended peripheral module. Enter DTCI or LTC.
	XPMNO	numeric (0 to 255)	Extended peripheral module number. Enter a numeric value.
PSLNKTAB		see subfields	P-side link table. Datafill subfields PSLINK, PSDATA, CARRIDX, ACTION, IID, and LINE_EQ as one concatenated entry. Separate the values with blanks. You are not prompted for the subfields individually. Enter a \$ to end the tuple.

**PRI Base Service** (continued)**Datafilling table LTCPSINV (Sheet 2 of 2)**

Field	Subfield or refinement	Entry	Explanation and action
	PSLINK	numeric	P-side link. Enter a number from 0 to 19 or the P-side port number for the DS-1.
	PSDATA	DS1PRA	P-side data. Enter DS1PRA.
	CARRIDX	alphanumeric (1 to 16 characters)	Carrier index. Enter the template name used in field TEMPLTNM in table CARRMTC. The default template name is DEFAULT.
PSLNKTAB	ACTION	Y or N	Action. Enter Y to indicate that the carrier is removed from service when the out-of-service limit for frame, slip, errored second, or severe errored second is exceeded. Enter N otherwise.
	IID	numeric (0 to 31)	Interface identifier. Enter a numeric value.  <b>Note:</b> For an interface with multiple DS-1s, each DS-1 must be assigned a unique IID. Primary and backup D-channels are no different. See correlation section for link to Meridian 1 PBX.
	LINE_EQ	110, 220, 330, 440, 550, 660, or NIL	Line equipment. This is the line length from the DS-1 circuit to the first DS-1 office repeater. This field replaces the DIP switches on NT6X50AA and NT6X50AB cards. Datafill this field as follows: <ul style="list-style-type: none"> <li>Enter NIL when the DS-1 carrier is not equipped with the NT6X50EC tuple in table CARRMTC.</li> <li>Enter the line length value used on the DIP switch (110, 220, 330, 440, 550, 660) if the DS-1 carrier is equipped with the NT6X50EC tuple in table CARRMTC.</li> </ul>

**Datafill example for table LTCPSINV**

The following example shows sample datafill for table LTCPSINV. (The other link entries remain in the default condition.)

## PRI Base Service (continued)

### MAP display example for table LTCPSINV

```

LTCNAME
PSLNKTAB

DTCI 2
(0 DS1PRA DEFAULT N 1 NIL) (1 DS1PRA DEFAULT
N 1 NIL) (2 DS1PRA DEFAULT N 1 NIL)
(3 DS1PRA DEFAULTL N 1 NIL) (4 DS1PRA DEFAULT
N 1 NIL) (5 DS1PRA DEFAULT N 1 NIL)
(6 DS1PRA DEFAULT N 1 NIL) (7 DS1PRA DEFAULT
N 1 NIL) (8 DS1PRA DEFAULT N 1 NIL)
(9 DS1PRA DEFAULT N 1 NIL) (10 DS1PRA DEFAULT
N 1 NIL) (11 DS1PRA DEFAULT N 1 NIL)
(12 DS1PRA DEFAULT N 1 NIL) (13 DS1PRA
DEFAULT N 1 NIL) (14 DS1PRA DEFAULT N 1 NIL)
(15 DS1PRA DEFAULT N 1 NIL) (16 DS1PRA
DEFAULT N 1 NIL) (17 DS1PRA DEFAULT N 1 NIL)
(18 DS1PRA DEFAULT N 1 NIL) (19 DS1PRA DEFAULT
N 1 NIL) $
    
```

### Datafilling table TRKSGRP

In PRI applications, table TRKSGRP defines the D-channel for the trunk group.

The following table shows the datafill specific to PRI Base Service for table TRKSGRP. Only those fields that apply directly to PRI Base Service are shown.

#### Datafilling table TRKSGRP (Sheet 1 of 6)

Field	Subfield or refinement	Entry	Explanation and action
SGRPKEY		see subfields	Subgroup key. Datafill subfields CLLI and SGRP as one concatenated entry. Separate the two values with a blank. You are not prompted for the subfields individually.
	CLLI	alphanumeric (1 to 16 characters)	Common language location identifier. From table CLLI, enter the trunk group name to which the subgroup belongs.
	SGRP	0	Subgroup. Enter 0 (zero).
CARDCODE		DS1SIG	Card code. Enter DS1SIG.



**PRI Base Service** (continued)

Datafilling table TRKSGRP (Sheet 2 of 6)

Field	Subfield or refinement	Entry	Explanation and action
SGRPVAR		see subfields	Subgroup variable refinements. This field consists of subfield SIGDATA and refinements PSPDSEIZ, PARTDIAL, VERSION, CRLENGTH, BCHNET, BCHGLARE, IFCLASS, CONFIG, LOCATION, SAT, ECSTAT, NSMATCH, TRKGRDTM, LIFLAGS, DCHNL, PMTYPE, DTCINO, LTCINO, DTCICKTNO, LTCCKTNO, DTCICKTTS, LTCCKTTS, DCHRATE, and HDLCTYPE.
	SIGDATA	ISDN	Subgroup variable. Enter ISDN.
	PSPDSEIZ	numeric (2 to 30)	Permanent signal or partial dial on seizure timing. Enter a numeric value to specify the number of seconds that the trunk waits for reception of the first digit.
	PARTDIAL	numeric (2 to 30)	Partial dial timing. Enter a numeric value to specify the number of seconds that the trunk waits for reception of each digit, except the first digit.
	VERSION	87Q931	Protocol version. Enter 87Q931.
	CRLENGTH	1 or 2	Call reference length. Enter 1 or 2 for the number of octets in the call reference.
	BCHNEG	N	B-channel negotiation. Enter N.
	BCHGLARE	STAND or YEILD	B-channel glare. When the B-channel is used in SETUP messages simultaneously in both directions. Enter one of the following values: <ul style="list-style-type: none"> <li>• STAND if this switch waits for the other switch to yield</li> <li>• YIELD if the call should be taken down by this switch</li> </ul> <p><b>Note:</b> When the switching node at the far end is another DMS-100 switch, one side must be STAND and the other YIELD.</p>

**PRI Base Service** (continued)

## Datafilling table TRKSGRP (Sheet 3 of 6)

Field	Subfield or refinement	Entry	Explanation and action
			Generally, enter YIELD at the DMS-100 switch when the switching node at the far end is a PBX that is not manufactured by Nortel. However, correlation of datafill with the PBX must be made.
	IFCLALSS	NETWORK	Interface class. Enter NETWORK for the network end of the PRI link.
	CONFIG	PPT_PT or PT_MLT_PT	Configuration. When broadcast procedures are to be used on this PRI interface. Enter one of the following values: <ul style="list-style-type: none"> <li>PT_PT for point-to-point</li> <li>PT_MLT_PT for point-to-multipoint</li> </ul>
	LOCATION	USER, PVTNET, or LOCALEO	Location. The location used when creating CAUSE information elements (IE). These CAUSE IE are contained in release messages that map to a specific treatment. Enter one of the following values: <ul style="list-style-type: none"> <li>USER for public network</li> <li>PVNET for private network</li> <li>LOCALEO for local end office (public network)</li> </ul>
	SAT	Y or N	Satellite. Enter Y when the trunk group is connected to the distant office using satellite. Otherwise, enter N.
	ECSTAT	INTERNAL, INNOTONE, EXTERNAL, or UNEQ	Echo canceller status. Enter one of the following values: <ul style="list-style-type: none"> <li>INTERNAL for internal processing and enabling by call processing</li> <li>INNOTONE for internal with inbound no tone</li> <li>EXTERNAL for external with no call processing involved</li> <li>UNEQ for unequipped</li> </ul>

**PRI Base Service** (continued)

Datafilling table TRKSGRP (Sheet 4 of 6)

Field	Subfield or refinement	Entry	Explanation and action
	NSMATCH	Y or N	<p>Noise match control. Enter Y for noise matching. The background noise levels are maintained when the internal echo canceller is actively cancelling echoes. Enter N for no noise matching. N is the default. The background noise levels are not maintained when the internal echo canceller is actively cancelling echoes.</p> <p><b>Note:</b> Use when field ECSTAT is INTERNAL and INNOTONE.</p>
	AUTOON	Y or N	<p>Automatic on. Enter Y for automatic re-enabling of the internal echo canceller. Y is the default. Enter N for no automatic re-enabling of the internal echo canceller.</p> <p><b>Note:</b> Use when ECSTAT is INTERNAL.</p>
	TRKGRDTM	numeric (1 to 255)	<p>Trunk guard timing. If the trunk group is outgoing or two-way, enter the time in 10 ms intervals that the trunk waits to receive on-hook from the far end before reporting lockout on the trunk. The timer begins when an on-hook signal is sent to the far end.</p> <p>If a new outgoing call is attempted on a trunk before on-hook is received from the far end, the peripheral delays outgoing trunk seizure until on-hook is received from the far end.</p> <p>If on-hook is received from the far end before this lockout timer expires, the new call is immediately attempted on the trunk. Otherwise, the trunk reports lockout and the call is re-attempted on another trunk.</p> <p>Enter a blank if the trunk is incoming.</p>

## PRI Base Service (continued)

### Datafilling table TRKSGRP (Sheet 5 of 6)

Field	Subfield or refinement	Entry	Explanation and action
	L1FLAGS	Y or N	<p>Layer 1 flags. Enter Y to indicate that the DTCI sends layer 1 flags when the D-channel is in footfall mode. Enter N to indicate that the DTCI does not send layer 1 flags when the D-channel is in footfall mode.</p> <p>When the switching node at the far end is manufactured by Nortel, enter N. When the switching node at the far end is not manufactured by Nortel, enter Y.</p> <p><b>Note:</b></p>
	DCHNL	see subfield	<p>D-channel. Defines the primary D-channel to use for this PRI interface. This field consists of subfield PMTYPE.</p> <p><b>Note:</b> Refer to "Datafilling Backup D-channel" when datafilling a backup D-channel. The subfields must be datafilled twice, once for the primary D-channel and once for the backup D-channel, and must be in the same tuple.</p>
	PMTYPE	DTCI or LTC	<p>Peripheral module type. Enter DTCI or LTC. If only a primary D-channel is required, enter a \$ to end the tuple after the primary D-channel is datafilled.</p>
	DTCINO	numeric (0 to 511)	<p>DTCI number. Enter the DTCI number.</p> <p><b>Note:</b> Use when PMTYPE is DTCI.</p>
	LTCNO	numeric (0 to 511)	<p>LTC number. Enter the LTCI number.</p> <p>Use when the PMTYPE is LTC.</p> <p><b>Note:</b></p>
	DTCICKTNO	numeric (0 to 19)	<p>DS-1 circuit number. Enter the DS-1 circuit number.</p>

**PRI Base Service** (continued)

Datafilling table TRKSGRP (Sheet 6 of 6)

Field	Subfield or refinement	Entry	Explanation and action
			<p>The primary D-channel must be datafilled on a lower DS-1 circuit number than the backup D-channel.</p> <p><b>Note:</b> Use when PMTYPE is DTCl.</p>
	LTCKTNO	numeric (0 to 19)	<p>DS-1 circuit number. Enter the DS-1 circuit number.</p> <p>The primary D-channel must be datafilled on a lower DS-1 circuit number than the backup D-channel.</p> <p><b>Note:</b> Use when PMTYPE is LTC.</p>
	DTCICKTTS	numeric (1 to 24)	<p>D-channel time slot number. Enter the time slot number of the D-channel. Normally 24.</p> <p><b>Note:</b> Use when PMTYPE is DTCl.</p>
	LTCKTTS	numeric (01 to 24)	<p>D-channel time slot number. Enter the time slot number of the D-channel. Normally 24.</p> <p><b>Note:</b> Use when PMTYPE is LTC.</p>
	DCHRATE	56K or 64K	<p>D-channel rate. Enter 56K or 64K for the data rate of the D-channel.</p> <p><b>Note:</b> This field must be compatible with subfield ZLG in table CARRMTC. If subfield ZLG is set to ZCS, DCHRATE must be 56K; if ZLG is B8ZS, DCHRATE must be 64K</p>
	HDLCTYPE	HDLC	<p>High level data link type. Enter HDLC for high level data link.</p>

**Datafill example for table TRKSGRP**

The following example shows sample datafill for table TRKSGRP.

## PRI Base Service (continued)

### MAP display example for table TRKSGRP

SGRPKEY	CARDCODE	SGRPVAR
SLINTPRI 0	DS1SIG	
ISDN 2 2 87Q931 1 N	STAND NETWORK	PTT_PT USER N UNEQ
30 N STRA	DTCI 0 0	24 64K HDLC
		\$

### Error message for table TRKSGRP

The following error messages apply to table TRKSGRP.

#### Error message for table TRKSGRP

Error message	Explanation and action
DCHRATE MISMATCH With ZLG FIELD IN CARRMTC	Field DCHRATE must be compatible with field ZLG in table CARRMTC. If ZLTG is set to ZCS, DCHRATE must be 56K. If ZLG is B8ZS, DCHRATE must be 64K.
NO OF DCHANNELS EXCEEDS MAXIMUM LIMIT.	The maximum number of D-channels that can be configured in the DTCI is 32. When a new tuple is added to table TRKSGRP, the tuple is accepted if the current number of D-channels configured on the PM is less than the maximum allowed. If it is greater, table LTMAP is checked to determine how many of the D-channels are mapped to an LTID. If the number of mapped D-channels is less than the maximum, the tuple is accepted. If not, this message is displayed.

### Datafilling table TRKMEM

Table TRKMEM contains an entry for each B-channel in the trunk group, defining the PM number, circuit number, and time slot number to which it is assigned.

**PRI Base Service** (continued)

The following table shows the datafill specific to PRI Base Service for table TRKMEM. Only those fields that apply directly to PRI Base Service are shown.

**Datafilling table TRKMEM (Sheet 1 of 2)**

Field	Subfield or refinement	Entry	Explanation and action
CLLI		alphanumeric (1 to 16 characters)	Common language location identifier. From table CLLI, enter the trunk group name.
EXTRKNM		numeric (1 to 479)	External trunk name. Enter an external number to identify the trunk member.  <b>Note:</b> To ensure that trunk selection is done in the correct order, this number should be the same as the DTCI circuit time slot number, subfield DTCICKTTS.
SGRP		0 (zero)	Subgroup. Enter 0 (zero), the only valid subgroup for ISDN signaling.
MEMVAR		see subfields	Member variables. This field consists of subfield PMTYPE and refinements DTCINO,LTCNO, DTCICKTNO, LTCKTNO, DTCICKTTS, and LTCKTTS (applicability of refinements depends upon PMTYPE value).
	PMTYPE	DTCI or LTC	Peripheral module type. Enter DTCI or LTC.
	DTCINO	numeric (0 to 511)	DTCI number. Enter a value for the DTCI number.  <b>Note:</b> Use when subfield PMTYPE is DTCI.
	LTCNO	numeric (0 to 511)	LTC number. Enter a value for the LTCI number.  Use when subfield PMTYPE is LTC.  <b>Note:</b>
	DTCICKTNO	numeric (0 to 19)	DS-1 circuit number. Enter a value for the DS-1 circuit number.  <b>Note:</b> Use when subfield PMTYPE is DTCI.

**PRI Base Service** (continued)

**Datafilling table TRKMEM (Sheet 2 of 2)**

Field	Subfield or refinement	Entry	Explanation and action
	LTCCKTNO	numeric (0 to 19)	DS-1 circuit number. Enter a value for the DS-1 circuit number.  <b>Note:</b> Use when subfield PMTYPE is LTC.
	DTCICKTTS	numeric (1 to 24)	B-channel time slot number. Enter a numeric value to specify the time slot number of the B-channel.  <b>Note:</b> Use when subfield PMTYPE is DTCL.
	LTCKTTS	numeric (1 to 24)	B-channel time slot number. Enter a numeric value to specify the time slot number of the B-channel.  Use when subfield PMTYPE is LTC.

**Note:** All members of a trunk subgroup (all B-channels serviced by the same D-channel) must be on the same DTCL. The D-channel for the trunk group is defined in table TRKSGRP.

**Datafill example for table TRKMEM**

The following example shows sample datafill for table TRKMEM.

**MAP display example for table TRKMEM**

CLLI	EXTRKNM	SGRP	MEMVAR
SL1NTPRI	1	0	DTCL 2 0 1

**Error message for table TRKMEM**

The following error messages apply to table TRKMEM.

**Error message for table TRKMEM**

Error message	Explanation and action
Peripheral does not exist	An attempt is made to enter a peripheral module that does not exist. Create the PM or check the table TRKMEM values for an error.



**PRI Base Service** (continued)**Datafilling table LTGRP**

The following table shows the datafill specific to PRI Base Service for table LTGRP. Only those fields that apply directly to PRI Base Service are shown. For a description of the other fields, refer to the data schema section of this document.

**Datafilling table LTGRP**

Field	Subfield or refinement	Entry	Explanation and action
GROUP		ISDN	Group name. Enter ISDN for the name of the LT group to which the PRI trunk group belongs.
GROUPNO		numeric (0 to 31)	Group number. Enter a numeric value to specify the group number.
OPTIONS		SAPI16	Options. Enter a \$ to end the tuple.  <b>Note:</b> SAPI16 is an automatic default.

**Datafill example for table LTGRP**

The following example shows sample datafill for table LTGRP.

**MAP display example for table LTGRP**

GROUP	GROUPNO	OPTIONS
ISDN	0	\$

**Datafilling table PRIPROF**

A new profile is created by adding a tuple to table PRIPROF. Multiple interfaces can share the same profile providing the variant and issue are the same. Interfaces with the same variant and issue do not have to use the same profile.

A profile is linked to an interface using field PROFNAME in table LTDEF as the key to table PRIPROF. The profile is software associated with a specific issue of a protocol variant. A function can be shared among various issues of a variant as well as among multiple variants. A profile is used when networking a switch or PBX that may not be fully compliant with PRI as

## PRI Base Service (continued)

implemented on the DMS-100. This table provides additional control of PRI variants on each interface.

The following table shows the datafill specific to PRI Base Service for table PRIPROF. Only those fields that apply directly to PRI Base Service are shown.

### Datafilling table PRIPROF (Sheet 1 of 2)

Field	Subfield or refinement	Entry	Explanation and action
PROFNAME		alphanumeric (up to 8 characters)	Profile name. Enter a profile name (with no underscores).  <b>Note:</b> This profile SL1PROFL has the five required function switches that must be used for linking to the Meridian 1 PBX.
VARINFO		see subfields	Variant information. This field consists of subfields VARIANT and ISSUE.
	VARIANT	NTNAPRI, U449PRI, or U459PRI	Protocol variant. Datafill this field as follows: <ul style="list-style-type: none"> <li>• Enter NTNAPRI when connecting switching nodes manufactured by Nortel.</li> <li>• Enter U449PRI when connecting to an AT&amp;T 5ESS switch.</li> <li>• Enter U459PRI when connecting to an AT&amp;T 5ESS switch.</li> </ul>
	ISSUE	V1	Variant issues. Enter V1.

**PRI Base Service** (continued)**Datafilling table PRIPROF (Sheet 2 of 2)**

Field	Subfield or refinement	Entry	Explanation and action
SWITCH		NOIALRT, XPLCTIID, CIDXBITO, CSE27T47, RMBCSE82, or NOSTATEQ	<p>Function switch. Enter one of the following names to specify the function switch:</p> <ul style="list-style-type: none"> <li>• CIDXBITO for set extension bit to zero</li> <li>• CSE27T47 for charge cause 27</li> <li>• NOIALRT for no progress alert message</li> <li>• NOSTATEQ for no status enquiry</li> <li>• RMBCSE82 for remote manual bust cause 82</li> <li>• XPLCTIID for explicit circuit identification</li> <li>• NIL for no profile</li> </ul> <p>These given function switches allow a profile to be set up. Enter a \$ to end the tuple. A profile with no function name is considered a nil profile.</p> <p><b>Note:</b> A nil profile is not visible and cannot be changed or deleted. It can be used by all issues of variants.</p>

**Datafill example for table PRIPROF**

The following example shows sample datafill for table PRIPROF

**MAP display example for table PRIPROF**

PROFNAME	VARINFO	SWITCH
NAPBX	NTNAPRI V1	
(NOIALRT)	(XPLCTID) (CIDXBITO)	(CSE27T47) (RMBCSE82) \$

## PRI Base Service (continued)

### Error messages for table PRIPROF

The following error messages apply to table PRIPROF.

#### Error message for table PRIPROF

Error message	Explanation and action
TUPLE REFERRED TO BY ANOTHER TABLE	An attempt was made to delete a tuple when a reference to the profile remains in table LTDEF. Remove the reference to the profile in table LTDEF before deleting the table PRIPROF tuple.

### Datafilling table LTDEF

Table LTDEF identifies Its and defines their access privileges. Since each PRI trunk group is considered the equivalent of a LT, it must be assigned a LTID and access privileges in table LTDEF. Protocol variant information is extracted from table PRIPROF.

The following table shows the datafill specific to PRI Base Service for table LTDEF. Only those fields that apply directly to PRI Base Service are shown.

#### Datafilling table LTDEF (Sheet 1 of 3)

Field	Subfield or refinement	Entry	Explanation and action
LTKEY		see subfields	Logical terminal key. Datafill subfields LTGRP and LTNUM as one concatenated entry. Separate the two values with a blank. You are not prompted for the subfields individually
	LTGRP	ISDN	Logical terminal group. Enter ISDN. <b>Note:</b> Same as field GROUP in table LTGRP.
	LTNUM	numeric (1 to 1022)	Logical terminal number. Enter a numeric value.
LTAP		B	Logical terminal access privilege. Enter B to specify circuit switching.
CLASSREF		see subfields	Class reference. This field consists of subfield LTCLASS and refinements.
	LTCLASS	PRA	Logical terminal class. Enter PRA.

**PRI Base Service** (continued)

Datafilling table LTDEF (Sheet 2 of 3)

Field	Subfield or refinement	Entry	Explanation and action
	NUMBCHNL	numeric (1 to 479)	Number of B-channels. Enter a numeric value.  <b>Note:</b> The same value as field TRKGRSIZ in table CLLI.
	NUMCALLS	numeric (1 to 479)	Number of calls. Enter a numeric value to specify the number of calls allowed on this logical interface at one time.  <b>Note:</b> The subfield NUMCALLS value must be greater than or equal to the sum of the subfields INCCALLS and OUTCALLS values.
	INCCALLS	numeric (0 to 479)	Incoming calls. Enter a numeric value to specify the number of reserved incoming-only calls that are allowed on this LT at one time.
	OUTCALLS	numeric (0 to 479)	Outgoing calls. Enter a numeric value to specify the number of reserved outgoing-only calls that are allowed on this LT at one time.  <b>Note:</b> Not used in PRI.
	VARISSUE	see subfields	Variant issue. This field consists of subfields VARIANT and ISSUE.  <b>Note:</b> Not used in PRI.
	VARIANT	NTNAPRI, U449PRI, or U459PRI	Protocol variant. Datafill this field as follows: <ul style="list-style-type: none"> <li>• Enter NTNAPRI when connecting switching nodes manufactured by Nortel.</li> <li>• Enter U449PRI when connecting to an AT&amp;T 4ESS switch.</li> <li>• Enter U459PRI when connecting to an AT&amp;T 5ESS switch.</li> </ul> <b>Note:</b> The subfields VARIANT, ISSUE, and PROFNAME must be in a defined tuple in table PRIPROF.

**PRI Base Service** (continued)

**Datafilling table LTDEF (Sheet 3 of 3)**

Field	Subfield or refinement	Entry	Explanation and action
	ISSUE	V1	Variant issue. Enter V1.  <b>Note:</b> The subfield VARIANT, ISSUE, and PROFNAME must be in a defined tuple in table PRIPROF.
	PROFNAME	alphanumeric (1 to 8 characters)	Profile name. Enter a name from table PRIPROF. Enter NIL for the default name.  <b>Note:</b> The subfields VARIANT, ISSUE, and PROFNAME must be in a defined tuple in table PRIPROF.
	OPTION	NOPMD, NOVOICE, NOVBD, NOCMD, or \$	Option. Controls the use of bearer capabilities (BC) on the PRI interface. Enter one of the following values: <ul style="list-style-type: none"> <li>• NOPMD to prevent packet-mode calls (This is the default.)</li> <li>• NOVOICE to prevent calls with a speech BC from originating or terminating on the PRI interface</li> <li>• MPVBD to prevent voice-band data calls</li> <li>• NOCMD to prevent circuit-mode data calls</li> <li>• \$to end the tuple</li> </ul>

**Datafill example for table LTDEF**

The following example shows sample datafill for table LTDEF.

**MAP display example for table LTDEF**

LTKEY	LTAP	CLASSREF
ISDN 1008	B	
PRA 10 10 0 0	NTNAPRI V1	SL1PROFL (NOPMD ) \$

---

**PRI Base Service** (continued)

---

**Error messages for table LTDEF**

The following error messages apply to table LTDEF.

**Error messages for table LTDEF**

Error message	Explanation and action
The sum of incoming calls and outgoing calls must be less than or equal to the number of calls allowed	The sum of values in subfields INCCALLS and OUTCALLS must be less than or equal to the value in subfield NUMCALLS. Adjust the values so the value in subfield NUMCALLS is greater than or equal to the sum of the values in subfields INCCALLS and OUTCALLS.

**Datafilling table LTMAP**

Table LTMAP associates the LTID assigned to the trunk group in table LTDEF with the trunk group CLLI.

The maximum number of D-channels that can be configured in the DTCHI is 32 and the LTC is 22. When a new tuple is added to table TRKSGRP, the tuple is accepted if the current number of D-channels configured on the PM is less than the maximum allowed. If it is greater, table LTMAP is checked to determine how many of the D-channels are mapped to an LTID. If the number of mapped D-channels is less than the maximum, the tuple is accepted.

The following table shows the datafill specific to PRI Base Service for table LTMAP. Only those fields that apply directly to PRI Base Service are shown.

**Datafilling table LTMAP (Sheet 1 of 2)**

Field	Subfield or refinement	Entry	Explanation and action
LTKEY		see subfields	Logical terminal key. Datafill subfields LTGRP and LTNUM as one concatenated entry. Separate the two values with a blank. You are not prompted for the subfields individually.  <b>Note:</b> Field LTID in table TRKGRP is updated automatically with the datafilled values.
	LTGRP	ISDN	Logical terminal group. Enter ISDN.
	LTNUM	numeric (1 to 1022)	Logical terminal number. Enter a numeric value.

**PRI Base Service** (continued)

**Datafilling table LTMAP (Sheet 2 of 2)**

Field	Subfield or refinement	Entry	Explanation and action
MAPPING		see subfields	Mapping. This field consists of subfield MAPTYPE and refinement CLLI.
	MAPTYPE	CLLI	Map type. Enter CLLI.
	CLLI	alphanumeric (1 to 16 characters)	Common language location identifier. From table CLLI, enter the trunk group name.
OPTION		see subfields	Option. This field consists of subfield OPTION and refinement TEI.
	OPTION	TEI	Option. Enter TEI.
	TEI	0 (zero)	Terminal midpoint identifier. Enter 0 (zero). Enter a \$to end the tuple.

**Datafill example for table LTMAP**

The following example shows sample datafill for table LTMAP.

**MAP display example for table LTMAP**

	LTKEY	MAPPING	OPTION
ISDN	1008	CLLI SL1NTPRI	( TEI 0 )\$

**Datafilling table LTCALLS**

The following table shows the datafill specific to PRI Base Service for table LTCALLS. Only those fields that apply directly to PRI Base Service are shown.

**Description of table LTCALLS (Sheet 1 of 5)**

Field	Subfield	Entry	Description
LTID		see subfields	Logical terminal identifier. This field consists of subfields LTGRP[, LTNUM, and CALLTYPE.
	LTGRP	alphanumeric (up to 8 characters)	Logical terminal group. Enter the logical terminal group name.



**PRI Base Service** (continued)**Description of table LTCALLS (Sheet 2 of 5)**

Field	Subfield	Entry	Description
	LTNUM	1–1022	Logical terminal number. Enter the logical terminal number within the group.
	Call type	ASDS, FX, HM, INWATS, LDS, PUB, PVT, SCOCS, TIE, WATS,	<p>Call type. Enter the call type associated with the LTID. The DMS switch can associate more than one type with the same identifier. Select from the following list of call types.</p> <ul style="list-style-type: none"> <li>• ASDS (Accunet Switched Digital Service) is an integrated services access (ISA) route selector used to route AT&amp;T Accunet CALLS.</li> <li>• FX (foreign exchange) provides a subscriber's location with the equivalent of local service from a distant exchange.</li> <li>• HM (hotel/motel) provides for hotel/motel services.</li> <li>• INWATS (Inward Wide Area Telecommunications Service) is a form of long distance service that allows a subscriber to receive calls originating within specified service areas, without a charge to the caller.</li> <li>• LDS (long distance service) is an ISA route selector used to route AT&amp;T world connect (international) calls.</li> <li>• PUB (public). A carrier can provide this call type.</li> <li>• PVT (private) provides private telephone services to a specific organization.</li> </ul>

**PRI Base Service** (continued)

**Description of table LTCALLS (Sheet 3 of 5)**

Field	Subfield	Entry	Description
			<ul style="list-style-type: none"> <li>• SCOCS (Selective Class of Call Screening) is an originating-only service that allows several distinct classes of service to be associated with a single PRI.</li> <li>• TIE (tie line) is a type of call that occurs on private lines between PBXs.</li> <li>• WATS (Wide Area Telecommunications Service) is provide by operating companies to permit subscribers to make calls over an access line to telephones in a specific zone.</li> </ul>
XLARTE	XLARTE	RTEREF, IBNRTE, XLAIBN, XLALEC	<p>Translations route. Enter one of the following translations routes.</p> <ul style="list-style-type: none"> <li>• RTEREF if translation is done by a specific table and index, such as OFRT, IBNRTE, and other routing tables</li> <li>• IBNRTE to indicate IBN route</li> <li>• XLAIBN for integrated business network (IBN) translations. This selection is used only in PBX or centrex offices.</li> <li>• XLALEC for local exchange carrier translations, such as plain old telephone service (POTS), or in PBX or centrex type offices. If the entry in subfield CALLTYPE is PVT, INWATS, or TIE the switch requires no other data.</li> </ul> <p>The entry of XLARTE - XLAIBN selection allows routing of the outgoing call to be altered such that the LINEATTR selected with the XLAIBN route selector is used for basic call screening only.</p>
	LINEATTR	0-31 999	<p>Line attributes index. Enter the index into table LINEATTR for service-related data.</p> <p>INDEX - The number of the route in the IBNRTE table.</p>

**PRI Base Service** (continued)**Description of table LTCALLS (Sheet 4 of 5)**

Field	Subfield	Entry	Description
	CUSTGRP	alphanumeric (up to 16 characters)	Customer group name. Enter customer name associated with an IBN station.
	SUBGRP	0-7	Subgroup number. Enter the subgroup number that further defines the selection of the CUSTGRP.
	NCOS	0-511	Network class of service. Enter the network class of service (NCOS) that determines the facilities to which the network user has access.
OPTIONS		EA, INCLID, LPIC, SIDXLA	Options - This field consists of subfield logical terminal option (LTCOPT) and refinements router name (RTRNAME), treatment with no service Identifier (TREAT_NO_SID), no call screen (NO_CALL_SCREEN), and route on translations route (ROUTE_ON_XLARTE).  LTOPT - SIDXLA (Enter SIDXLA to allow service identifier OUTWATS Banded call type.)

**PRI Base Service** (continued)

**Description of table LTCALLS (Sheet 5 of 5)**

Field	Subfield	Entry	Description
			<p>RTRNAME - Enter the OUTWATS router name built in table ISAXLA for routing OUTWATS Banded Service.</p> <p>TREAT_NO_SID - Y (This field determines whether calls without an associated service identifier should be sent to treatment. Enter Y to indicate that the call should be sent to treatment. Enter N to route the call using the numbering plan indicator, network specific facility, and the called digits.)</p> <p>NO_CALL_SCREEN - Y (This field allows call screening on the line attribute index to avoided. Enter Y to indicate that validation is not done on the directory number. Enter N to indicate that call screening is done using the line attribute index defined in field LINEATTR.)</p> <p>ROUTE_ON_XLARTE -Y (This field determines whether a call is routed through public or private translations based on the entry in field XLARTE rather than the NPI in the setup message. Enter Y to indicate that the XLARTE overrides the NPI. Enter N to indicate that the NPI determines the type of translation.)</p>

**Datafill example for table LTCALLS.**

The following example shows sample datafill for table LTCALLS.

**Example of table LTCALLS**

LTID		XLARTSEL		OPTIONS	
ISDN	150 PUB	XLALEC	300		(EA MCI222 Y)\$
ISDN	150 INWATS	XLAIBN	300	ISDN2	0 0 (INCLID SUPPRESS)\$
ISDN	150 WATS	XLAIBN	300	ISDN2	0 0\$
ISDN	150 FX	XLAIBN	300	PBXGROUP	0 0 (SIDXLA PRIFX Y Y N)\$
ISDN	150 TIE	RTEREF	IBNRTE	1007	

---

**PRI Base Service** (end)

---

**Translation verification tools**

PRI Base Service does not use translation verification tools.

**SERVORD**

PRI Base Service does not use SERVORD.

## PRI Bearer Capability Routing

---

### Ordering codes

Functionality group ordering codes: NI000008, NI000014

Functionality ordering code: not applicable

### Release applicability

BCS36 and up

### Prerequisites

To operate, PRI Bearer Capability Routing has the following prerequisites

- NI0 ISDN Base, NI000007
- MDC - MDC Minimum, MDC00001

### Description

PRI Bearer Capability Routing is the capability which enables the routing of ISDN calls based on routing characteristics.

Call routing is described in terms of PRI originations and PRI terminations. As shown in figure "PRI originations and terminations," a PRI origin is defined as a call that originates in the DMS-100 switch. A PRI termination is defined as a call that terminates in the DMS-100 switch. A call that begins and ends on PRI terminals in the DMS-100 switch is both a call origination and a call termination.

For calls terminating at the DMS-100 switch, routing characteristics are defined in the SETUP message that is transmitted with the call. For call originations, the DMS-100 switch creates a SETUP message that specifies the routing characteristics of the call.

#### PRI originations and terminations

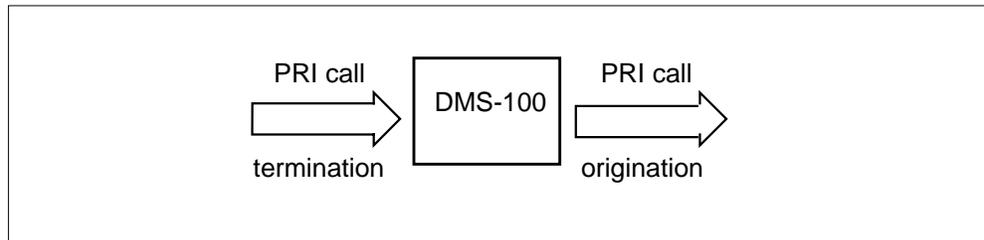

---

## PRI Bearer Capability Routing (continued)

---

### Operation

#### Call originations

When a call originates at a PRI terminal in the DMS-100 switch, it is routed to an outgoing trunk based on the switch datafill. The originating terminal sends a SETUP message to the switch, which uses the information elements to begin routing the call. The SETUP message is analyzed in the same manner as is an incoming SETUP message for a call termination. During the translations and routing process, more routing characteristic information is collected, and a second SETUP message containing this information is generated when the call goes out to another node.

#### Routing the call

Figure "PRI call originations" is a flow diagram which shows a simplified translations process for call originations. The translations process is as follows:

1. The call begins in the standard translations tables and proceeds towards standard routing tables. However, as the SETUP message identifies the call as having bearer capability, table XLAMAP is accessed before any routing tables.
2. Table XLAMAP is accessed with the original translator name derived from standard translations and the routing characteristics name (RCNAME) obtained from table RTECHAR. It is checked for a new translator to enable alteration of the route based on bearer capability. Table TRKRCSEL screens the routing characteristics for individual trunk groups.
3. For a private call, the translator from XLAMAP is used to access table IBNXLA, which provides an index to a routing table (IBNRTE or OFRT).
4. Before accessing the routing table for private call processing, a mapping table (IBNMAP or OFRTMAP) is checked for a new route based on bearer capability. The mapping table is accessed with the routing index from table IBNXLA and the RCNAME, and provides a new index to the routing table.
5. For a public call, table XLAMAP provides a line attribute index to table LINEATTR. Table LINEATTR provides a pretranslator index to table STDPRTCT. Before accessing table STDPRTCT, table PXLAMAP is accessed with the pretranslator index and the RCNAME, and checked for a new pretranslator index based on bearer capability.
6. The new pretranslator index is used to access table STDPRTCT, which contains an index to routing table RTEREF. Before table RTEREF is accessed, mapping table RTEMAP is checked for a new routing index based on bearer capability.

## **PRI Bearer Capability Routing** (continued)

---

7. For both private and public calls, the routing table is accessed with the new index from the mapping table. The routing table uses the ISA selector to route the call, specifying the trunk CLLI, the call type, the NPI, and a digit manipulation index.
8. Table TRKGRP is accessed with the CLLI from the routing table, and provides the LTID assigned to the trunk. With the LTID and the call type (from the routing table), table LTCALLS is accessed. If a tuple is found in table LTCALLS for the LTID and call type, the call is allowed to go through to the trunk.
9. The call is routed to the trunk specified in table IBNRTE, and a SETUP message is generated.

### **Generating the SETUP message**

When the DMS-100 generates a SETUP message for an originating PRI call, the CDN and BC data is derived from the original SETUP message from the terminal, and altered during the translations and routing process, if necessary. The NPI information for the message is obtained from the routing table for both private and public calls.

In the case of a private call, another information element, the network specific facilities (NSF) is generated. The NSF contains the call type and an optional service identifier, and is typically used for FX, TIE, and WATS calls. For private calls, an NSF of PRVT (private) is generated, but is typically not used at the terminating node.

Table TRKRCSEL allows the capability of turning on or off routing on different information elements (IE). If this table is not datafilled for a particular trunk, only BC is defaulted to ON. Other IEs, even if they exist in the SETUP message, are not used for determining the routing characteristics



### PRI Bearer Capability Routing (continued)

#### PRI call originations

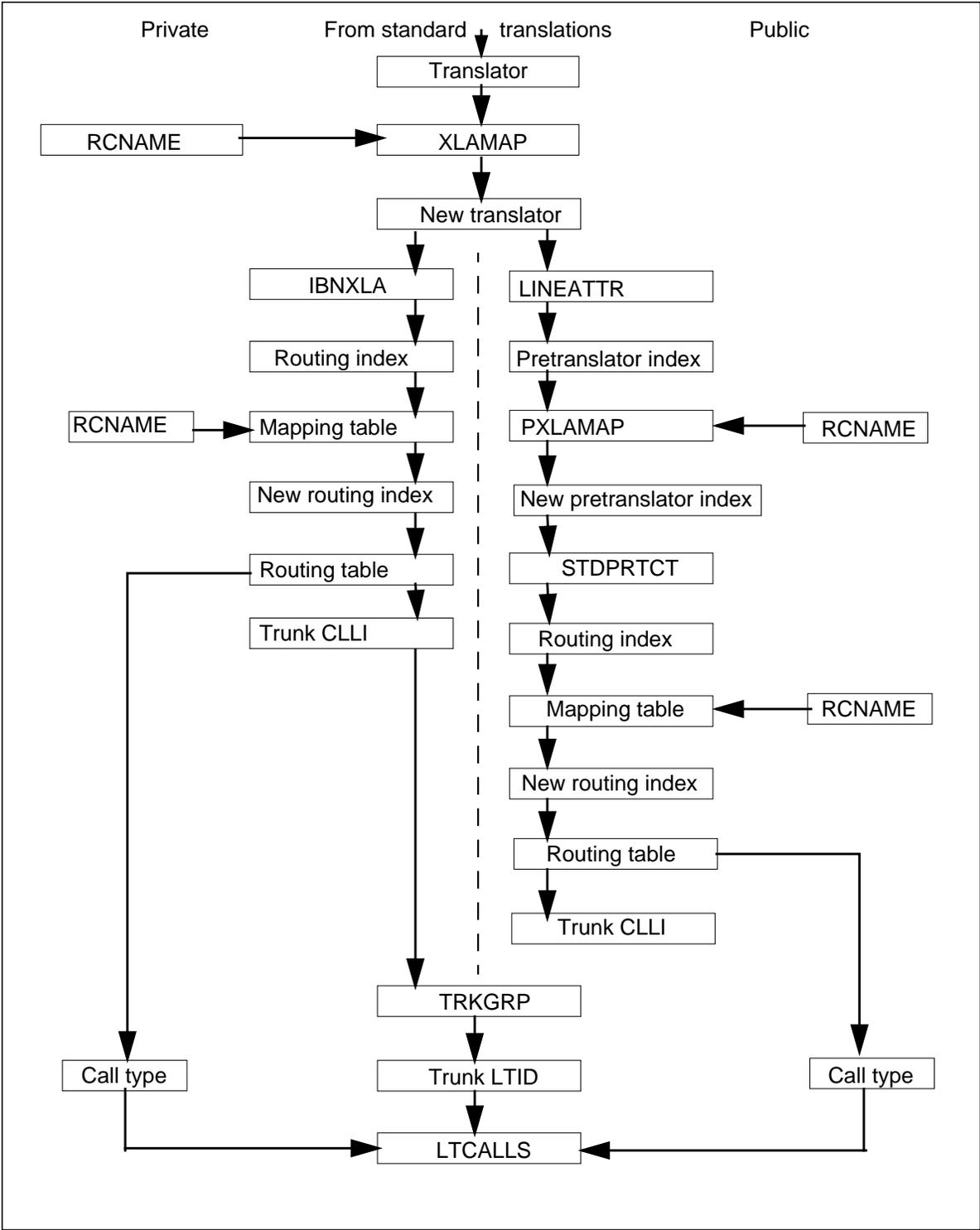

## PRI Bearer Capability Routing (continued)

---

### Call terminations

When a PRI call is received, the DMS-100 routes the call based on the call's SETUP message and the switch datafill. The process of routing a call requires these main steps:

- analyzing the SETUP message
- determining the call type
- determining the routing characteristics of the call
- routing the call

### Analyzing the SETUP message

The SETUP message provides the information which allows the call routing system to determine the called number, the call type, and the call's routing characteristics. Combined with the switch datafill, these factors determine the translations that are used to route the call.

The SETUP message is composed of information elements (IE), each of which provides a part of the setup data. The primary IEs analyzed by the call routing system are:

- the called party number (CDN) IE
- the bearer capability (BC) IE

Table "SETUP information elements" summarizes the content and use of the information elements.

*Note:* There is also a transit network selector (TNS) IE.

### Determining the call type

The two primary call types for a PRI call are public (PUB) and private (PVT). Table "PRI call types" provides a brief definition of each call type.

To determine the call type of a PRI call, the DMS-100 examines the CDN IE for the type of number (TON) and numbering plan indicator (NPI) information. Together, the TON and NPI indicate whether the numbering plan used for the called number is private or public.

The call type determined from the SETUP message is used to access table LTCALLS, which begins call translations.

*Note:* There is routing for the other call types (FX, TIE, INWATS, and OUTWATS).

---

## PRI Bearer Capability Routing (continued)

---

### Determining routing characteristics

The routing characteristic information from the SETUP message is analyzed to derive an ISDN routing characteristic name (RCNAME), which helps to determine the translation path of the call.

The call routing system uses data from the BC IE to access table BCDEF and obtain a bearer capability name (BCNAME) which represents those transmission characteristics. The BCNAME is used to access table RTECHAR, which contains sets of routing characteristics assigned to RCNAMEs. Comparing the BCNAME to the content of RTECHAR gives the routing system an RCNAME, which is then used to represent the call's routing characteristics throughout the rest of the translation and routing process.

### SETUP information elements (Sheet 1 of 2)

Information element	Purpose
Keypad (KP)	May contain the dialed digits and any feature access codes.

**PRI Bearer Capability Routing** (continued)

**SETUP information elements (Sheet 2 of 2)**

Information element	Purpose
Called party number (CDN)	<p>May contain:</p> <ul style="list-style-type: none"> <li>• the dialed digits</li> <li>• the type of network (TON), which specifies a nationally standardized network or a private network</li> <li>• the network plan identifier (NPI), which is one of: an Inter-LATA carrier identification code, a user-specific identification code, or unknown</li> </ul> <p>Together, the TON and NPI indicate whether the numbering plan used for the called number is private or public. They can specify an international, national, or local number in the ISDN numbering plan (E.164), or a network-specific number in a private numbering plan.</p> <p>When the CDN contains the dialed digits, they are used for the called digits, and the keypad IE digits are ignored.</p>
Bearer capability (BC)	<p>Defines the transmission service used by the call. The BC value is one of: speech (digital voice transmission), unrestricted digital information (at 64 kbit/s), or 3.1 kHz audio.</p>

---

## PRI Bearer Capability Routing (continued)

---

The following table shows the PRI call types private and public.

### PRI call types

Call type	Definition
private (PVT)	Connects the customer group to its private network (for example, a corporate network).
public (PUB)	Connects the customer to the public switching network. The digits dialed conform to E.164 standards. (E.164 refers to the public network numbering plan, which is in accordance with CCITT recommendation E164; in effect, E164 refers to the North American public numbering plan.)

### Routing the call

Once the SETUP message has been analyzed and an RCNAME obtained, the translation system tables route the call. Figure "PRI call types" is a flow diagram which shows a simplified translations process for call terminations. The translations process is as follows:

1. Call terminations processing in the DMS-100 begins with the trunking tables, which define the attributes of the trunk group. Table TRKGRP contains the trunk group LTID, one of the keys used to access table LTCALLS, which provides the initial information for translating the call. The other key to table LTCALLS is the call type from the SETUP message.
2. Table LTCALLS begins the translations process differently depending on whether the call is private or public. For a private call, the NCOS code or the customer group name from LTCALLS is used to obtain a preliminary translator name from table NCOS or CUSTHEAD. For a public call, the line attribute index from table LTCALLS is used to obtain a pretranslator for the call.
3. For a private call, the preliminary translator and the RCNAME derived from table RTECHAR are the keys to table XLAMAP. Table XLAMAP can be datafilled with a new translator to enable alteration of the route based on bearer capability. For a public call, the pretranslator and an RCNAME are used to access table PXLAMAP, which is datafilled with a new pretranslator.
4. The new translator from table XLAMAP or pretranslator from PXLAMAP is used to access table IBNXLA (for private calls) or table

## **PRI Bearer Capability Routing** (continued)

---

STDPRTCT (for public calls), which provides the routing index into standard translations.

5. When the translations route includes one of the routing tables (IBNRTE, OFRT, or HNPACONT.RTEREF), a mapping table (IBNMAP, OFRTMAP, or HNPACONT.RTEMAP) may be datafilled to alter the translations route for an ISDN call. In these cases, the RCNAME associated with the call and the original routing index are used to access the mapping table, which provides a new index to the routing table.
6. An RCNAME can also be datafilled in the routing tables (IBNXLA, IBNRTE, OFRT, and RTEREF) to enable retranslations based on routing characteristics.

*Note:* The standard IBN translations tables mentioned in this document are described in the *Translations Guide*.

### **Datafilled bearer capabilities for PTS trunks**

To provide flexibility in routing incoming calls, the DMS-100 switch allows the operating company to assign bearer capabilities to PTS trunk groups. A bearer capability for a trunk group is defined in table TRKGRP to override the office-wide default BC.

Table BCDEF contains all the possible BC names and their associated transmission characteristics. At installation, BCDEF is datafilled with ten default tuples which cannot be deleted. The ones of interest are: SPEECH, 3\_1KHZ, 56KDATA, and 64KDATA. The operating company may also add BC names of their own definition to table BCDEF.

**PRI Bearer Capability Routing** (continued)

**PRI call terminations**

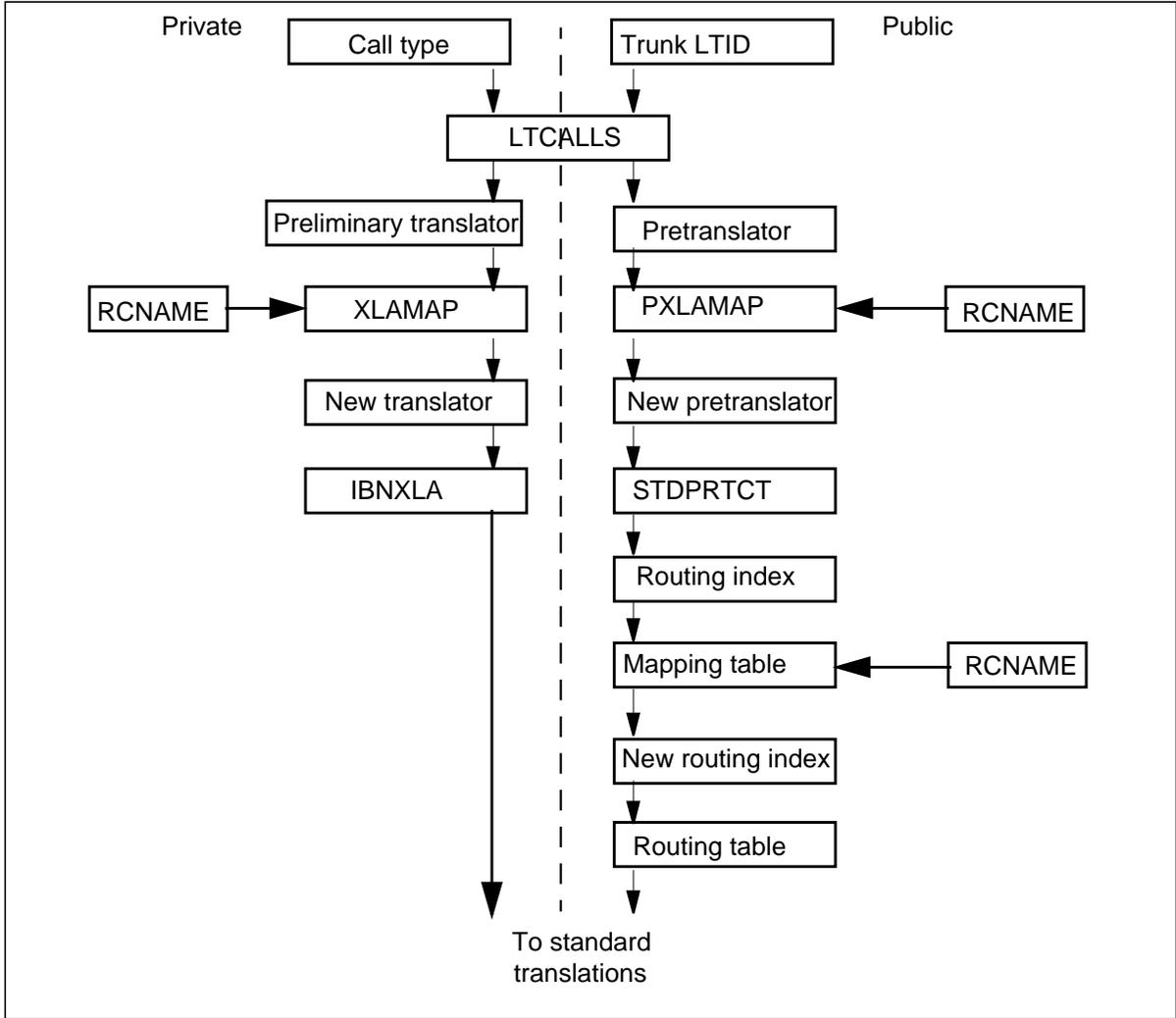

**Translations table flow**

**Call originations**

The PRI Bearer Capability Routing translation process for call originations is shown in the two flowcharts that follow. The first flowchart illustrates the process for a private call, and the second for a public call.

Processing of a PRI call origination begins with table KSETLINE, and continues through the standard translations tables. Ordinarily, the process continues to standard routing tables, but when there is a bearer capability associated with the call, table XLAMAP is accessed first.

## PRI Bearer Capability Routing (continued)

---

The PRI Bearer Capability Routing translations tables are described in the following list:

- Table XLAMAP is accessed with the original translator and the RCNAME associated with the call. For a private call, table XLAMAP provides a new translator to access table IBNXLA. The tuple in table IBNXLA specifies an index to a routing table (IBNRTE or OFRT).

For a public call, table XLAMAP provides a line attribute index, LINEATTR, to table LINEATTR, which contains a pretranslator index, PRTNM, to table STDPRTCT.

- Table RCNAME contains the valid routing characteristics names.
- Table BCDEF is accessed with the transmission characteristics from the SETUP message, and provides the BCNAME which represents these characteristics.
- Table TRKRCSSEL controls the routing capabilities that can be turned on or off for individual trunk groups.
- Table RTECHAR is accessed with the routing characteristics from the SETUP message and the BCNAME from BCDEF, and provides the RCNAME on which further routing is based.
- Table PXLAMAP is used in public call translations to alter the route for an ISDN call. It is accessed with the RCNAME associated with the call and the standard pretranslator name from table LINEATTR, and provides a new pretranslator index to table STDPRTCT. Table STDPRTCT contains an index to routing table RTEREF.
- Table IBNMAP or OFRTMAP is accessed (for private calls) before the routing table to check for a new route based on bearer capability. The key to the mapping table is the routing index from IBNXLA and the RCNAME. The mapping table provides a new index to the routing table.
- Table RTEMAP is accessed (for public calls) with the routing index from table STDPRTCT and the RCNAME, and provides a new index to routing table RTEREF based on bearer capability.
- Table IBNRTE, OFRT, or RTEREF uses the ISA selector to route the call. The routing table defines the CLLI of the trunk to which the call is to be routed, and specifies the call type and the NPI, which is mapped to the SETUP message created for the call. The routing table may also indicate a digit manipulation index, which is used to access table DIGMAN.
- Table TRKGRP is accessed with the trunk CLLI from the routing table, and provides the LTID assigned to the trunk. The LTID is used to access table LTCALLS.



---

## PRI Bearer Capability Routing (continued)

---

- Table LTCALLS is accessed with the trunk group LTID and the call type from the routing table. If a tuple is found for the LTID and call type, the call is allowed to go through.
- Table DIGMAN may be accessed with the digit manipulation index from the routing table, to allow the called number digits to be modified before outpulsing. (For instance, table DIGMAN might be required to remove a prefix from the dialed digits or add a prefix to them.)

The call is routed to the specified trunk, and a SETUP message is generated containing the called number digits, the NPI defined in the routing table, an NSF for private calls, and the bearer capability.

The PRI Bearer Capability Routing translation process for a private call is shown in the flowchart that follows.

**PRI Bearer Capability Routing** (continued)

Table flow for PRI Bearer Capability Routing originations (private call)

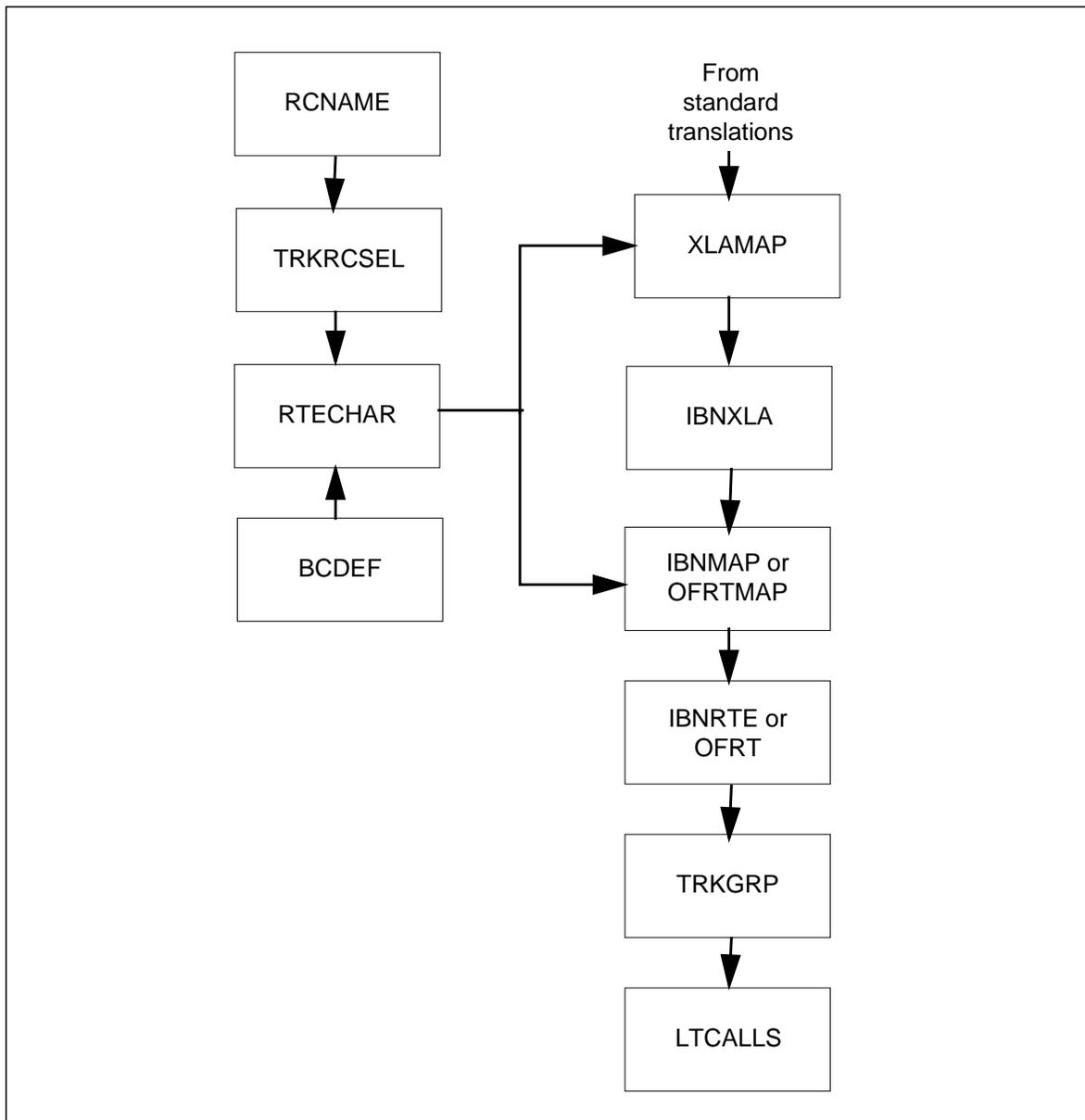

The PRI Bearer Capability Routing translation process for a public call is shown in the flowchart that follows.

**PRI Bearer Capability Routing** (continued)

Table flow for PRI Capability Routing originations (public call)

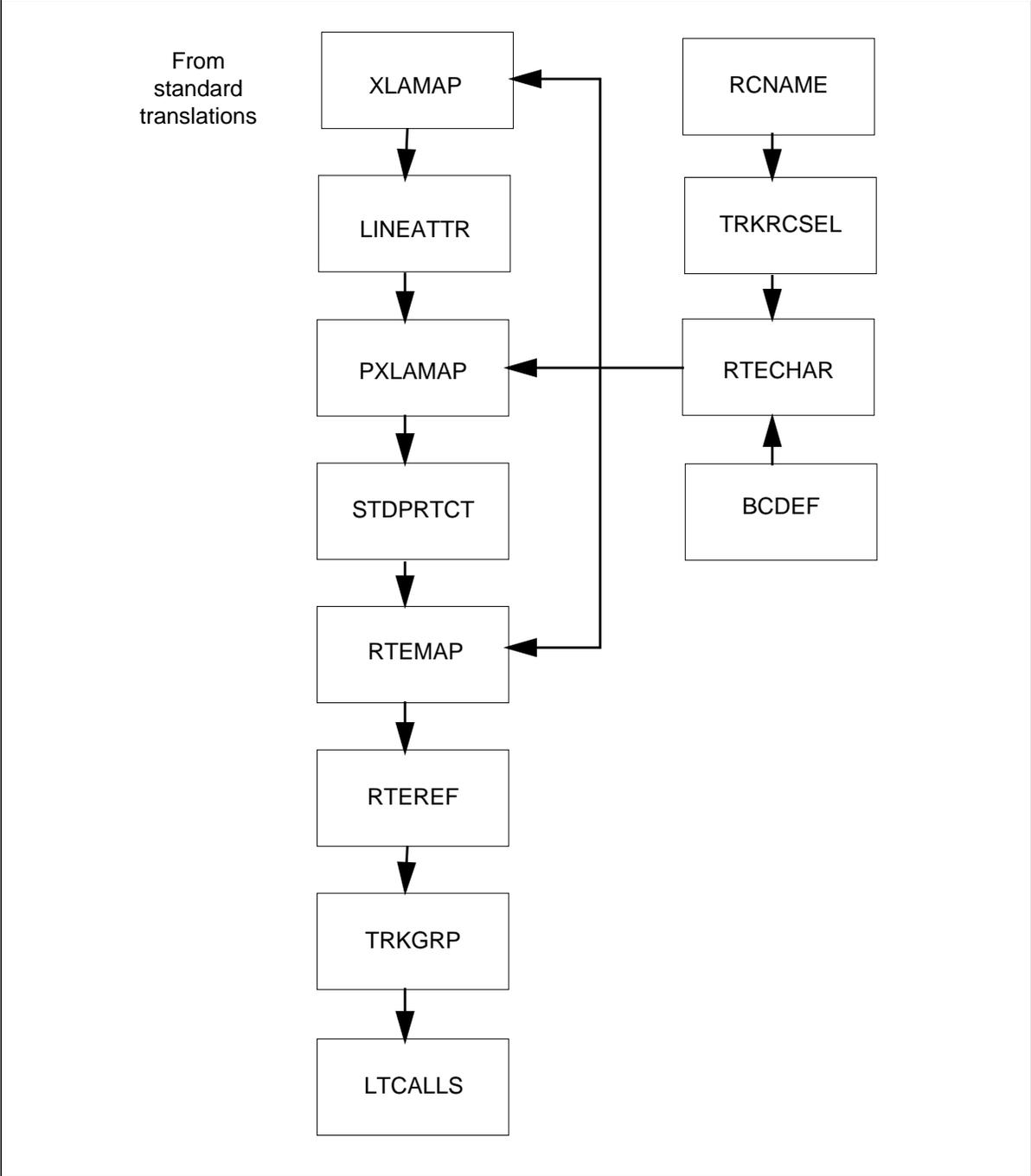

**PRI Bearer Capability Routing** (continued)

The following table lists the datafill content used in the flowchart Bearer Capability Routing originations (private call)

**Example datafill used in flowchart originations (private call)**

Item	Example data
Called number	15983
Calling number	6215982
NPI	PVT
BC	64KDATA

The following shows example datafill used for the flowchart.

**Example datafill used in flowchart originations (private call)**

Datafill table	Example data
RCNAME	56KDATA
TRKRCSEL	BNRPRAOG BC ON
RTECHAR	56KDATA BC 56KDATA \$ \$
KSETLINE	WITS 2 1 DN Y 6215982 IBNTST 0 0 613 RAG LNR SFC CFX \$
DNATTRS	613 621 5982 PUBLIC NAME WITS_2 \$ \$ \$
NCOS	IBNTST 0 0 0 TST10 XLAS CXT1 RXCFN NDGT OHQ 0 TONE_OHQ CBQ 0 1 Y 2 \$
CUSTHEAD	IBNTST NXLA CXT3 RXCFN 0 TST1
XLAMAP	56KDATA CXT3 XLA CXT2 \$
IBNXLA	CXT2 1 ROUTE N Y N 1 N 2 18 POTS N T IBNRTE 800
IBNMAP	56KDATA 800 700
IBNRTE	700 ISA N N N BNRPRAOG PVT 0 PVT 15 \$
TRKGRP	BNRPRAOG PRA 0 PRAC NCRT ASEQ N ISDN 500 \$ \$
LTCALLS	ISDN 500 PVT XLAIBN 0 IBNTST 0 0 \$
DIGMAN	15 INC 401 \$

---

## PRI Bearer Capability Routing (continued)

---

The following table lists the datafill content used in the flowchart “Bearer Capability Routing originations (public call)”.

### Example datafill for flowchart originations (public call)

Item	Example data
Called number	99605983
Calling number	6215982
NPI	E164
BC	64KDATA

The following table lists the datafill content used in the flowchart “Bearer Capability Routing originations (public call)”.

### Example datafill for flowchart originations (public call) (Sheet 1 of 2)

Datafill table	Example data
RCNAME	56KDATA
TRKRCSEL	BNRPRAOG BC ON
RTECHAR	56KDATA BC 56KDATA \$ \$
KSETLINE	WITS 2 1 DN Y 6215982 IBNTST 0 0 613 RAG LNR SFC CFX \$
XLAMAP	56KDATA CXT3 LINEATTR 0 \$
LINEATTR	0 1FR NONE NT FR01 0 613 P621 L613 TSPS 10 NIL NILSFC LATA1 NIL NIL NIL 00 \$
PXLAMAP	56KDATA P601 XLA P621 \$
STDPRTCT	P621 1 0 0
STDPRT	66 69 N NP 0 NA
HNPACONT	66 69 N NP 0 NA
HNPACODE	660 660 LRTE 13
RTEMAP	56KDATA 13 710
RTEREF	710 T ISA N N N BNRPRAOG PUB NONE N N 20
TRKGRP	BNRPRAOG PRA 0 PRAC NCRT ASEQ N ISDN 800 \$ \$

## PRI Bearer Capability Routing (continued)

### Example datafill for flowchart originations (public call) (Sheet 2 of 2)

Datafill table	Example data
LTCALLS	ISDN 800 PUB XLAIBN 0 IBNTST 0 0 \$
DIGMAN	20 REM 3 INC 401 \$

### Call terminations

The PRI Bearer Capability Routing translation process for call terminations is shown in the two flowcharts that follow. The first flowchart illustrates the process for a private call, and the second for a public call.

For the incoming call, table CLLI identifies the trunk group, and table TRKMEM determines the physical location of the circuit carrying the call. The trunk identifier (CLLI) is used to access table TRKSGRP, which defines the signaling protocol used by the trunk, and table TRKGRP, which provides the LTID of the trunk group. The LTID and the call type from the SETUP message are used to access table LTCALLS.

- Table LTCALLS provides the customer group field, CUSTGRP, and the network class of service field, NCOS, for a private call. The customer group and NCOS fields are used to access table NCOS for a preliminary translator name, PRELIMXLA, which is the key for table IBNXLA. If there is no translator in table NCOS, the customer group from table LTCALLS, CUSTGRP, is used to access table CUSTHEAD, which contains a customer group translator, CUSTXLA. CUSTXLA is used to key into table XLAMAP.

For a public call, table LTCALLS provides the line attribute index, LINEATTR, which is used to access table LINEATTR. LINEATTR contains a pretranslator name, PRTNM, which is used to key into table PXLAMAP.

- Table RCNAME contains the valid routing characteristics names.
- Table BCDEF is accessed with the transmission characteristics from the SETUP message, and provides the BCNAME which represents these characteristics.
- Table RTECHAR is accessed with the routing characteristics from the SETUP message and the BCNAME from BCDEF, and provides the RCNAME on which further routing is based. For a private call, the RCNAME is used with CUSTXLA from table CUSTHEAD (or PRELIMXLA from table NCOS) to key into table XLAMAP. For a public call, the RCNAME is used with PRTNM from table LINEATTR to key into table PXLAMAP.

---

## PRI Bearer Capability Routing (continued)

---

- Table XLAMAP provides a new translator for private calls, based on the original translator and the RCNAME. The new translator is used to access table IBNXLA, which begins standard translations.
- Table PXLAMAP provides a new translator for public calls, based on the original translator and the RCNAME. The new translator is used to access table STDPRTCT, which begins standard translations.

When the translations route includes one of the routing tables (IBNRTE, OFRT, or RTEREF), the corresponding mapping table (IBNMAP, OFRTMAP, or RTEMAP) is accessed before the routing table.

*Note:* Mapping table IBNMAP is accessed when the routing table is IBNRTE, table OFRTMAP is accessed when the routing table is OFRT, and subtable HNPACONT.RTEMAP is accessed when the routing table is subtable HNPACONT.RTEREF.

- Table IBNMAP, OFRTMAP, or RTEMAP provides a new routing index to table IBNRTE, OFRT, or RTEREF, based on the original routing index and the RCNAME.

The following shows the table flow for PRI Capability Routing terminations for a private call.

## PRI Bearer Capability Routing (continued)

Table flow for PRI Bearer Capability Routing terminations (private call)

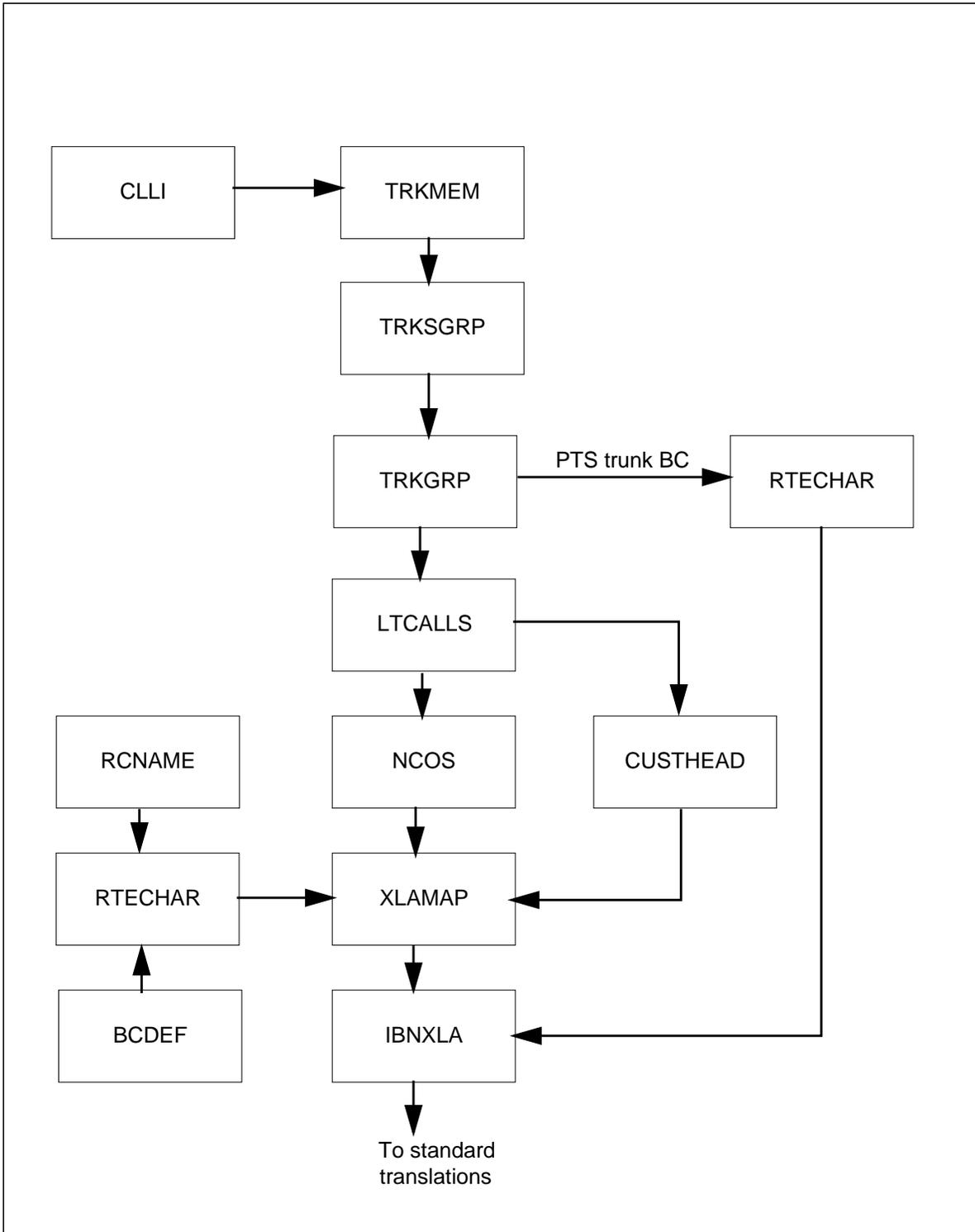



---

## **PRI Bearer Capability Routing** (continued)

---

The following shows the table flow for PRI Capability Routing terminations for a public call.

## PRI Bearer Capability Routing (continued)

Table flow for PRI Bearer Capability Routing terminations (public call)

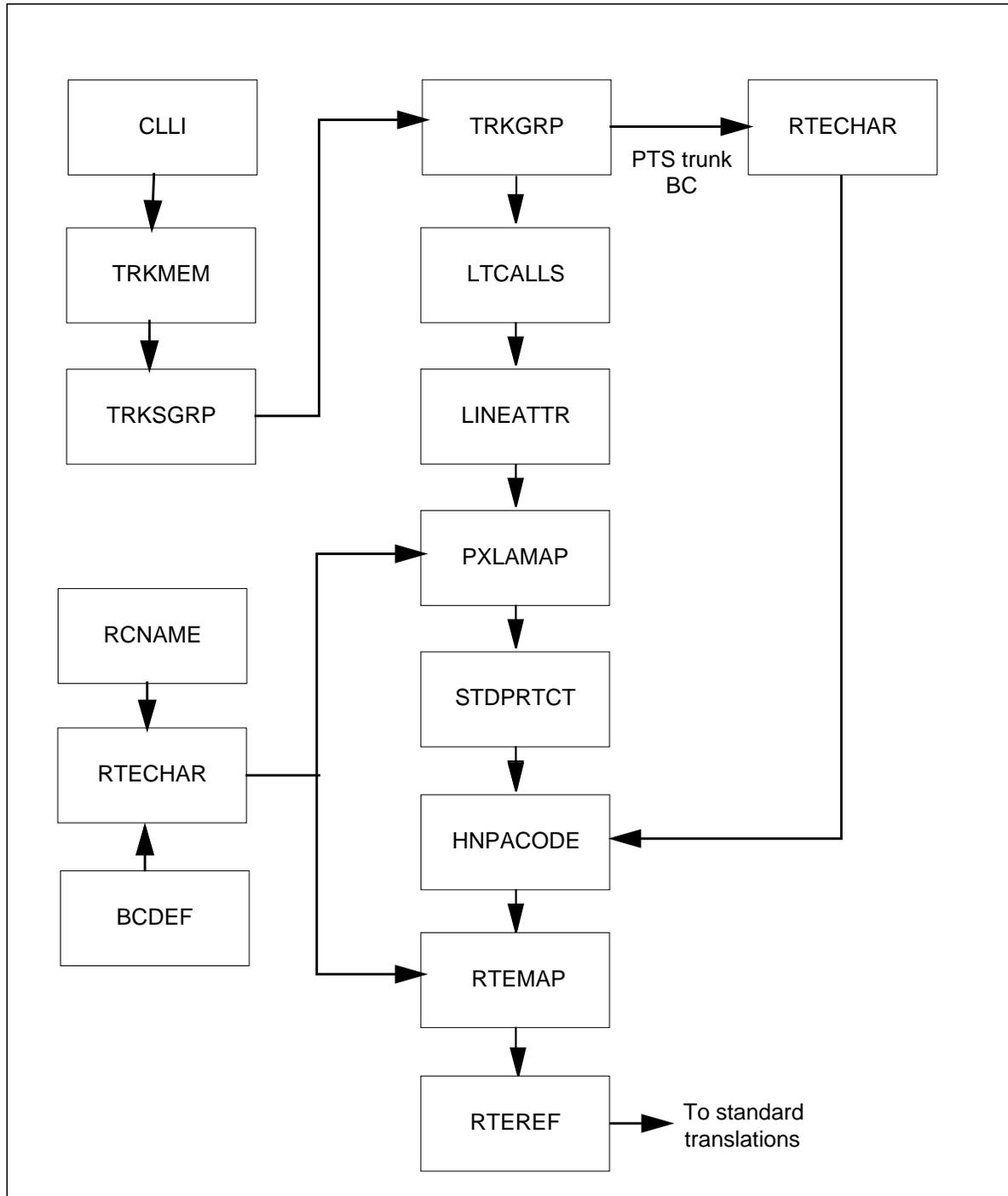

---

## PRI Bearer Capability Routing (continued)

---

The following table lists the datafill content of the tables in the flowchart example of "Bearer Capability Routing terminations (private call)".

### Example datafill for PRI Bearer Capability Routing terminations (private call)

Item	Example data
Called number	55982
NPI	PVT
BC	56KDATA

The following table lists the datafill content of the tables in the flowchart example of "Bearer Capability Routing terminations (private call)".

### Example datafill for PRI Bearer Capability Routing terminations (private call)

Datafill table	Example data
RCNAME	56KDATA
RTECHAR	56KDATA BC 56KDATA \$ \$
TRKGRP	BNRPRAIC PRA 0 PRAC NCRT DSEQ N LTID ISDN 501 \$ \$
LTCALLS	ISDN 501 PVT XLAIBN 0 IBNTST 0 0 \$
CUSTHEAD	IBNTST NXLA TECXLA CXLA 0 TST1 \$
XLAMAP	56KDATA TECXLA XLA CETXLA \$
IBNXLA	CETXLA 5 EXTN Y Y Y 613 621 5 \$
TOFCNAME	613 621
DNINV	613 621 5982 ILC WITS 2
DNATTRS	613 621 5982 PUBLIC NAME WITS_2 \$ \$ \$

The following table lists the datafill content of the tables in the flowchart example of "Bearer Capability routing terminations (public call)".

### Example datafill for PRI Bearer Capability Routing terminations (public call) (Sheet 1 of 2)

Item	Example data
Called number	4015213

## PRI Bearer Capability Routing (continued)

### Example datafill for PRI Bearer Capability Routing terminations (public call) (Sheet 2 of 2)

Item	Example data
NPI	E164
BC	56KDATA

The following table lists the datafill content of the tables in the flowchart example of "Bearer Capability routing terminations (public call)".

### Example datafill for PRI Bearer Capability Routing terminations (public call)

Datafill table	Example data
RCNAME	56KDATA
RTECHAR	56KDATA BC 56KDATA \$ \$
TRKGRP	BNRPRAIC PRA 0 PRAC NCRT DSEQ N LTID ISDN 501 \$ \$
LTCALLS	ISDN 501 PUB XLAIBN 0 IBNTST 0 0 \$
LINEATTR	0 IFR NONE NT FR01 0 613 P600 L613 TSPS 10 NIL NILSFC LATA1 NIL NIL NIL 00
PXLAMAP	56KDATA P600 XLA P621 \$
STDPRTCT	P621 1 0 0
STDPRT	40 410 N NP 0 NA
HNPACONT	613 710 2 39 1 0 2 0
HNPACODE	401 401 LRTE 401
RTEMAP	56KDATA 401 410
RTEREF	410 DN 613 722

---

## PRI Bearer Capability Routing (continued)

---

### Limitations and restrictions

The following limitations and restrictions apply to PRI Bearer Capability Routing:

- The datafilled BC capability is provided only for incoming trunks. It does not affect outgoing trunks, except that the datafilled BC is listed in the outgoing initial address message (IAM).
- The datafill in table TRKRCSEL applies only to PRI calls coming into the switch. The datafill is not applicable to any other type of feature that uses ISDN translations.
- Turning on a particular IE in table TRKRCSEL implies that routing according to the content of that IE is allowed for that specific trunk group. However, corresponding tables for ISDN translations (for example, RCNAME and RTECHAR) must be datafilled before that IE can be used in translations.
- The datafilled BC capability applies to A5, ATC, IBNT2, IBNTI, IT, OC, OP, PX, SC, T2, TI, and TOPS PTS trunks. (For any other incoming PTS trunk group types, the office default BC applies.) Even if a PRI or ISUP trunk is datafilled with a BC, it is ignored. If a trunk group with both PTS and non-PTS trunk subgroups is datafilled with a BC, it applies only to the PTS subgroup, not to the non-PTS subgroup.

### Interactions

PRI Bearer Capability Routing has no functionality interactions.

### Activation/deactivation by the end user

PRI Bearer Capability Routing requires no activation or deactivation by the end user.

### Billing

PRI Bearer Capability Routing affects billing as follows: if the BC option is datafilled against the customer group in table CUSTSMR, an SMDR extension record is generated identifying the type of bearer capability.

### Station Message Detail Recording

PRI Bearer Capability Routing does not affect Station Message Detail Recording.

## PRI Bearer Capability Routing (continued)

### Datafilling office parameters

The following table shows the office parameters used by PRI Bearer Capability Routing. For more information about office parameters, refer to Office Parameters Reference Manual.

#### Office parameters used by PRI Bearer Capability Routing

Table name	Parameter name	Explanation and action
OFCENG	NUM_RC_EXT_BLKs	<p>This parameter (number of routing characteristics extension blocks) specifies the number of extension blocks required for translation and routing of calls based on routing characteristics. The default for the parameter is 0 (zero), but it is recommended that the operating company calculate the value as one block for each call, based on the probable number of simultaneous calls using ISDN translations. Note that such calls include calls on any trunk group that does not have the default BC (for instance, a PTS trunk group datafilled with a non-default BC).</p> <p>This parameter defines the office-wide default bearer capability, which is the value applied to an incoming trunk if no BC is defined in table TRKGRP. The default for DEFAULT_BEARER_CAPABILITY is SPEECH.</p> <p><b>Note:</b> It is recommended that the default remain at SPEECH. If the default BC is changed, the new default is applied only to trunk groups datafilled after the change. Any trunk groups datafilled before the change retain the previous default BC value. This situation can cause problems, because these trunks become non-default BC trunk groups and require RC extension blocks. If NUM_RC_EXT_BLKs is set too low to accommodate these extra trunk groups, calls can be dropped. To solve the problem, the non-default BC trunk groups must be datafilled again.</p>
OFCENG	DEFAULT_BEARER_CAPABILITY	

---

## PRI Bearer Capability Routing (continued)

---

### Datavill sequence

The following table lists the tables that require datavill to implement PRI Bearer Capability Routing. The tables are listed in the order in which they are to be datavilled

#### Datavill tables required for PRI Bearer Capability Routing (Sheet 1 of 2)

Table	Purpose of table
BCDEF	Bearer Capability Definition. This table contains bearer capability names and their associated transmission characteristics.
TRKGRP	Trunk Group. This table defines a bearer capability for an incoming PTS trunk group.
RCNAME	ISDN Routing Characteristic Name. This table contains the valid routing characteristics names (RCNAME).
IBNRTE	IBN Route. This table provides a route for the originating call and specifies the SETUP message information. Alters the routing index for a call retranslation based on the RCNAME.
OFRT	Office Route. This table provides a route for the originating call and specifies the SETUP message information. Alters the routing index for a call retranslation based on the RCNAME.
HNPACONT subtable RTEREF	Home Numbering Plan Area Code Subtable Route Reference Subtable Record. This table provides a route for the originating call and specifies the SETUP message information. Alters the routing index for a call retranslation based on the RCNAME.
IBNMAP	ISDN Routing Map. This table is a prerouting table used to alter the routing index to IBNRTE for calls with an associated RCNAME.
OFRTMAP	ISDN OFRT Route Reference. This table is a prerouting table used to alter the routing index to OFRT for calls with an associated RCNAME.
HNPACONT subtable RTEMAP	ISDN Home NPA Route Reference Subtable Record. This table is a prerouting table used to alter the routing index to RTEREF for calls with an associated RCNAME.
XLAMAP	ISDN Translation Map. This table is a pretranslation table used to alter the translator name for private calls with an associated RCNAME.
PXLAMAP	ISDN Pretranslations Map. This table is a pretranslation table used to alter the translator name for public calls with an associated RCNAME.
IBNXLA	IBN Translation. This table provides a translator for the call when it must be retranslated according to an RCNAME.

## PRI Bearer Capability Routing (continued)

### Datafill tables required for PRI Bearer Capability Routing (Sheet 2 of 2)

Table	Purpose of table
LTCALLS	Logical Terminal Calls. This table specifies the types of calls that can be routed over the interface and provides initial translations for the call.
TRKRCSSEL	Trunk Routing Characteristics Selection. This table allows PRI trunks to optionally turn on and off the routing capability using any particular type of ISDN IE.
RTECHAR	ISDN Routing Characteristics. This table associates an RCNAME with a set of routing characteristics.

### Datafilling table BCDEF

Table BCDEF contains all the valid bearer capability names. Each tuple in the table lists a BCNAME and its associated transmission characteristics, which include the trunk's transfer capability, transfer mode, and coding standard. The BCNAME is used in table RTECHAR to represent its associated transmission characteristics.

The following table shows the datafill specific to PRI Bearer Capability Routing for table BCDEF. Only those fields that apply directly to PRI Bearer Capability Routing are shown. For a description of the other fields, refer to the data schema section of this document.

### Datafilling table BCDEF (Sheet 1 of 2)

Field	Subfield or refinement	Entry	Explanation and action
KEY		see subfield	Key. This is made up of subfield BCNAME.
	BCNAME	alphanumeric (up to 16 characters)	Bearer capability name. Enter a name (up to 16 characters) for the BC.
BCDATA		see subfields	Bearer capability data
	XFERCAP	SPEECH, RESDIG, UNRESDIG or AU3_1KHZ	Transfer capability. Enter one of the following values: <ul style="list-style-type: none"> <li>• SPEECH for standard voice calls</li> <li>• RESDIG for 56-kbit/s transparent data transfer.</li> <li>• UNRESDIG for unrestricted digital information at 64-kbit/s.</li> <li>• AU3_1KHZ for audio data at 3.1 kHz.</li> </ul>



## PRI Bearer Capability Routing (continued)

### Datafilling table BCDEF (Sheet 2 of 2)

Field	Subfield or refinement	Entry	Explanation and action
	XFERMOD	PACKET or CIRCUIT	Transfer mode. Enter one of the following values: <ul style="list-style-type: none"> <li>• PACKET for packet data service.</li> <li>• CIRCUIT for circuit-switched service</li> </ul>
	CODINGST	CCITT or NETWORK	Coding standard. Enter one of the following values: <ul style="list-style-type: none"> <li>• Enter CCITT to indicate that the CCITT coding standards are being used.</li> <li>• Enter NETWORK to indicate that network-specific standards are being used.</li> </ul>

### Datafill example for table BCDEF

The following example shows sample datafill for table BCDEF

### MAP display example for table BCDEF

KEY	BCDATA
64KDATA	UNRESDIG CIRCUIT CCITT

### Error messages for table BCDEF

Not applicable

### Datafilling table TRKGRP

The following table shows the datafill specific to PRI Bearer Capability Routing for table TRKGRP. Only those fields that apply directly to PRI Bearer

**PRI Bearer Capability Routing** (continued)

Capability Routing are shown. For a description of the other fields, refer to the data schema section of this document.

**Datafilling table TRKGRP**

Field	Subfield or refinement	Entry	Explanation and action
GRPINFO		see subfields	Group information  Group type. Enter one of the following values: <ul style="list-style-type: none"> <li>• A5 for AMR5 two-way trunks</li> <li>• ATC for access to carrier</li> <li>• IBNT2 for MDC two-way</li> <li>• IBNTI for MDC incoming</li> <li>• IT for intertoll incoming</li> <li>• OC for outgoing CAMA</li> <li>• OP for TSPS tandem trunks</li> <li>• PX for PBX direct inward dialing</li> <li>• SC for super CAMA incoming</li> <li>• T2 for two-way end office</li> <li>• TI for incoming end office</li> <li>• TOPS for traffic operating position</li> </ul>
	GRPTYP	A5, ATC, IBNT2, IBNTI, IT, OC, OP, PX, SC, T2, TI, or TOPS	
	OPTION	BCNAME or \$	Option. Enter a \$ to end the tuple.
	BCNAME	SPEECH, 64KDATA, 64KX25, 56DATA, DATAUNIT, 64KRES, 3_1KHZ, 7_KHZ, or VOICE_DATA	Bearer capability name. Enter a BC name defined in subfield BCNAME in table BCDEF. Assigns a BC to a PTS or PRI trunk group.

**Note:** If no BC is datafilled for a trunk group, the office default applies. If the datafilled BC for a trunk group is the same as the office default, it will not appear in the listed tuple when the TRKGRP tuple for the trunk group is listed. If the datafilled BC is not supported on the outgoing protocol, the call is routed to treatment.

**Datafill example for table TRKGRP**

The following example shows sample datafill for table TRKGRP.

---

## PRI Bearer Capability Routing (continued)

---

### MAP display example for table TRKGRP

GRPKEY	GRPINFO
SL1NTPRI	
IBNTI 1 ATT NCLT NETMVP 2 0 99 ANSDISC 1 Y 2 2 Y Y Y Y N 7 O N N Y DLSE Y Y IBN DEFAULT (REGION 1) \$ \$ NATL (BCNAME 64KDATA) \$	

### Error messages for table TRKGRP

Not applicable

### Datafilling table RCNAME

Table RCNAME contains all the valid routing characteristic names. Each tuple in the table lists an RCNAME, which is associated with a group of routing characteristics in table RTECHAR. The RCNAME is used in tables throughout the translations and routing process to represent its associated routing characteristics.

The following table shows the datafill specific to PRI Bearer Capability Routing for table RCNAME. Only those fields that apply directly to PRI Bearer Capability Routing are shown. For a description of the other fields, refer to the data schema section of this document.

#### Datafilling table RCNAME

Field	Subfield or refinement	Entry	Explanation and action
NAMEKEY		alphanumeric (1 to 8 characters)	Routing characteristics name. Enter a name (up to eight characters) to represent a set of routing characteristics defined in table RTECHAR.

### Datafill example for table RCNAME

The following example shows sample datafill for table RCNAME.

## PRI Bearer Capability Routing (continued)

### MAP display example for table RCNAME

NAMEKEY
64KRTE

### Error messages for table RCNAME

Not applicable

### Datafilling table IBNRTE

The following tables show the datafill specific to PRI Bearer Capability Routing for table IBNRTE. Only those fields that apply directly to PRI Bearer Capability Routing are shown. For a description of the other fields, refer to the data schema section of this document.

The first of the following two tables shows the datafill required to route an originating PRI call and ensure that the call type and NPI are available for the creation of the SETUP message. The ISA routing selector is datafilled for this purpose.

The second table shows the datafill that allows the operating company to alter the routing characteristics of a call for retranslation based on the RCNAME. The RC option in the RX retranslation selector is datafilled for this purpose.

**Note:** There are four IBN routing tables, named IBNRTE, IBNRT2, IBNRT3, and IBNRT4, all of which operate identically. In this document, the term IBNRTE is used to refer to all the IBN routing tables.

The following table shows the field descriptions for table IBNRTE.

#### Datafilling table IBNRTE (Sheet 1 of 3)

Field	Subfield or refinement	Entry	Explanation and action
RTE		0 to 1023	Route reference index. Enter a number from 0 to 1023 for the sequential route index for the table.
RTELIST		see subfield	Route list. There can be up to eight RTELIST entries per tuple.
	IBNRTSEL	ISA or \$	IBN route selector. Enter ISA for integrated services access. Enter a \$ to end the tuple.

---

**PRI Bearer Capability Routing** (continued)

---

Datafilling table IBNRTE (Sheet 2 of 3)

Field	Subfield or refinement	Entry	Explanation and action
	OHQ	Y or N	Off-hook queuing. Enter Y if off-hook queuing is required. Enter N if off-hook queuing is not required.
	CBQ	Y or N	Call-back queuing. Enter Y if call-back queuing is required. Enter N if call-back queuing is not required.
	EXP	Y or N	Expensive. Enter Y for an expensive route. Enter N for an inexpensive route.
	CLLI	alphanumeric	Common language location identifier. From table CLLI, enter the trunk group name.
	CALLTYPE	PUB or PVT	Call type. Enter one of the following values: <ul style="list-style-type: none"> <li>• PUB for public routing.</li> <li>• PVT for private routing.</li> </ul>
	OATYPE	NONE	Operator access type. Enter NONE. Use when subfield CALLTYPE is PUB.
	TNS	N	Transit network. Enter N. <b>Note:</b> Use when subfield CALLTYPE is PUB.
	NPOS	Y or N	Number identification. Enter Y if no calling number identification is required. Enter N if calling number identification is required. <b>Note:</b> Use when subfield CALLTYPE is PUB.
	FACNUM	0 (zero)	Facility number. Enter 0 (zero). <b>Note:</b> Use when subfield CALLTYPE is PVT.

## PRI Bearer Capability Routing (continued)

### Datafilling table IBNRTE (Sheet 3 of 3)

Field	Subfield or refinement	Entry	Explanation and action
	NPI	PVT	<p>Network plan identifier. Enter PVT for private.</p> <p><b>Note:</b> Use when subfield CALLTYPE is PVT.</p>
	DMI	1 to 31999, 0	<p>Digit manipulation index. Enter a number from 1 to 31999 for the index into table DIGMAN that contains the modification for the called number. Enter 0 (zero) if the DMI is not required.</p> <p><b>Note:</b> Use when subfield CALLTYPE is PUB or PVT.</p>

The following table shows the datafill that allows the operating company to alter the routing characteristics of a call for retranslation based on the RCNAME.

### Datafilling table IBNRTE for retranslation (Sheet 1 of 2)

Field	Subfield or refinement	Entry	Explanation and action
RTE		0 to 1023	Route reference index. Enter a number from 0 to 1023 for the sequential route index for the table.
RTELIST		see subfields	Route list. There can be up to eight RTELIST entries per tuple.
	IBNRTSEL	RX or \$	IBN route selector. Enter RX for retranslation. Enter a \$ to end the tuple.
	CUSTNAME	CUSTHEAD	Customer group name. Enter the code assigned to the customer group datafilled in table CUSTHEAD.
	SUBGRP	0 TO 7	Subgroup. Enter a number from 0 to 7.
	NCOS	0 TO 511	Network class of service number. Enter a number from 0 to 511 to be used for the retranslation environment.
	DMI	1 to 31999, 0	Digit manipulation index. Enter a number from 1 to 31999 for the index into table DIGMAN that contains the modification for the called number. Enter 0 (zero) if the DMI is not required.

---

## PRI Bearer Capability Routing (continued)

---

### Datafilling table IBNRTE for retranslation (Sheet 2 of 2)

Field	Subfield or refinement	Entry	Explanation and action
	OPTION	RC	Option. Enter RC to indicate that retranslation is to be based on an RCNAME.
	RCNAME		Routing characteristics name. Enter the name from table RCNAME on which retranslation is to be based.

### Datafill example for table IBNRTE

The following example shows sample datafill using the ISA route selector in a private call route for table IBNRTE.

#### MAP display example for table IBNRTE

RTE	RTELIST
21	( ISA Y Y Y SL1NTPRI PVT 0 PVT 15)\$

The following example shows sample datafill using the RX route selector for table IBNRTE.

#### MAP display example for table IBNRTE

RTE	RTELIST
20	( RX BNA 0 0 104 (RC 64KRTE)\$)\$

### Error messages for table IBNRTE

Not applicable

### Datafilling table OFRT or RTEREF

The following table shows the datafill specific to PRI Bearer Capability Routing for table OFRT or subtable HNPACONT.RTEREF. Only those fields that apply directly to PRI Bearer Capability Routing are shown. For a description of the other fields, refer to the data schema section of this document.

## PRI Bearer Capability Routing (continued)

The first of the following two tables show the datafill required to route an originating PRI call and ensure that the call type and NPI are available for the creation of the SETUP message. The ISA routing selector is datafilled for this purpose.

The second table on page shows the datafill that allows the operating company to alter the routing characteristics of a call for retranslation based on the RCNAME. The RC option in the RX retranslation selector is datafilled for this purpose.

**Note:** There are four office routing tables, named OFRT, OFRT2, OFRT3, and OFRT4, all of which operate identically. In this document, the term OFRT is used to refer to all the office routing tables.

The following table shows the datafill required to route an originating PRI call and ensure that the call type and NPI are available for the creation of the SETUP message.

**Datafilling table OFRT (Sheet 1 of 2)**

FIELD	Subfield or refinement	Entry	Explanation and action
RTE		0 to 1023	Route reference index. Enter a number from 0 to 1023 for the sequential route index for the table.
RTELIST		see subfields	Route list. There can be up to nine RTELIST entries per tuple.
	RTESEL	ISA or \$	Route selector. Enter ISA for integrated services access. Enter a \$ to end the tuple.
	OHQ	Y or N	Off-hook queuing. Enter Y if off-hook queuing is required. Enter N if off-hook queuing is not required.
	CBQ	Y or N	Call-back queuing. Enter Y if call-back queuing is required. Enter N if call-back queuing is not required.
	EXP	Y or N	Expensive. Enter Y for an expensive route. Enter N for an inexpensive route.
	CLLI	alphanumeric	Common language location identifier. From table CLLI, enter the trunk group name.



---

**PRI Bearer Capability Routing** (continued)

---

Datafilling table OFRT (Sheet 2 of 2)

FIELD	Subfield or refinement	Entry	Explanation and action
	CALLTYPE	PUB or PVT	Call type. Enter PUB for public routing. Enter PVT for private routing.  Operator access type. Enter NONE.
	OATYPE	NONE	<b>Note:</b> Use when subfield CALLTYPE is PUB.  Transit network. Enter N.
	TNS	N	<b>Note:</b> Use when subfield CALLTYPE is PUB.  Number identification. Enter Y if no calling number identification is required. Enter N if calling number identification is required.
	NPOS	Y or N	<b>Note:</b> Use when subfield CALLTYPE is PUB.
	FACNUM	0 (zero)	Facility number. Enter 0 (zero).  Network plan identifier. Enter PVT for private.
	NPI	PVT	<b>Note:</b> Use when subfield CALLTYPE is PVT.  Digit manipulation index. Enter a number from 1 to 31999 for the index into table DIGMAN that contains the modification for the called number. Enter 0 (zero) if the DMI is not required.
	DMI	1 to 31999, 0	<b>Note:</b> Use when subfield CALLTYPE is PUB or PVT.

## PRI Bearer Capability Routing (continued)

The following table shows the datafill that allows the operating company to alter the routing characteristics of a call for retranslation based on the RCNAME.

**Datafilling table OFRT**

Field	Subfield or refinement	Entry	Explanation and action
RTE		0 to 1023	Route reference index. Enter a number from 0 to 1023 for the sequential route index for the table.
RTELIST		see subfields	Route list. There can be up to nine RTELIST entries per tuple.
	RTESEL	RX or \$	IBN route selector. Enter RX for retranslation. Enter a \$ to end the tuple.
	STS	numeric	Serving translation scheme. Enter the NPA of the home NPA code table that will be accessed with the retranslation RCNAME.
	TYPECALL	DD, NP or OA	Type of call. Enter DD for direct dial. Enter NP for no prefix. Enter OA for operator assisted.
	DMI	1 to 31999, 0	Digit manipulation index. Enter a number from 1 to 31999 for the index into table DIGMAN that contains the modification for the called number. Enter 0 (zero) if the DMI is not required.
	BILLDMI	0 to 31999	DMI billing number. Enter a number from 0 to 31999 for the DMI used to alter the billing number.
	OPTION	RC	Option. Enter RC to indicate that retranslation is to be based on an RCNAME.
	RCNAME	alphanumeric or blank	Routing characteristics name. Enter the name from table RCNAME on which retranslation is to be based.

### Datafill example for table OFRT or RTEREF

The following example shows sample datafill using the ISA route selector in a private call route for table OFRT or RTEREF

---

## PRI Bearer Capability Routing (continued)

---

**MAP display example for table OFRT or RTEREF**

RTE	RTELIST
21	( ISA Y Y Y SL1NTPRI PVT 0 PVT 15 )\$

The following example shows sample datafill using the RX route selector for the PRI Bearer Capability Routing in table OFRT or RTEREF.

**MAP display example for table OFRT or RTEREF**

RTE	RTELIST
10	(RX 519 DD 230 230 (RC 64KDATA)\$)\$

**Error messages for table OFRT or RTEREF**

Not applicable

**Datafilling table IBNMAP, OFRTMAP, or RTEMAP**

The following table shows the datafill specific to PRI Bearer Capability Routing for tables for IBNMAP or OFRTMAP or subtable HNPACONT.RTEMAP. (These three mapping tables are identical, so they are described once only.). Only those fields that apply directly to PRI Bearer Capability Routing are shown. For a description of the other fields, refer to the data schema section of this document.

The mapping tables contain a routing index for ISDN calls with an associated RCNAME. The tables are accessed with the RCNAME associated with the call and the original routing index, and provide a new index to their corresponding routing table:

- table IBNMAP contains the mapping for routing table IBNRTE
- table ORFTMAP contains the mapping for routing table OFRT
- subtable HNPACONT.RTEMAP contains the mapping for routing subtable HNPACONT.RTEREF

## PRI Bearer Capability Routing (continued)

The following table shows the datafill for tables IBNMAP, OFRTMAP, or RTEMAP.

### Datafilling table IBNMAP, OFRTMAP, or RTEMAP

Field	Subfield or refinement	Entry	Explanation and action
KEY		see subfields	Key field. Datafill the subfields RCNAME and INDEX as one concatenated entry. Separate the two values with a blank. You are not prompted for the subfields individually.
	RCNAME	alphanumeric	Routing characteristics name. Enter the name from table RCNAME associated with the call.
	INDEX	0 to 1023	Index. Enter a number from 0 to 1023 for the original route reference index.
NEWINDEX		0 to 1023	New index. Enter a number from 0 to 1023 for the route reference index to the ISDN list in the routing table.

### Datafill example for table IBNMAP, OFRTMAP, or RTEMAP

The following example shows sample datafill for table IBNMAP, OFRTMAP, or RTEMAP.

### MAP display example for table IBNMAP, OFRTMAP, or RTEMAP

	KEY	NEWINDEX
64KRTE	1	100

### Error messages for table IBNMAP, OFRTMAP, or RTEMAP

Not applicable

### Datafilling table XLAMAP

The following table shows the datafill specific to PRI Bearer Capability Routing for table XLAMAP. Only those fields that apply directly to PRI Bearer Capability Routing are shown. For a description of the other fields, refer to the data schema section of this document.

---

## PRI Bearer Capability Routing (continued)

---

Table XLAMAP is a pretranslation table used for private calls which associates the original MDC translator name from table NCOS or CUSTHEAD and the call's RCNAME with a new translator name, a line attribute, or a routing index. Two sets of new translations data can be associated with each original translator and RCNAME.

As shown in the following figure, the selector values in subfield SEL determines the next stage of translations for the call:

- The XLA selector provides a new translator name to be used in table IBNXLA.
- The LINEATTR selector provides a line attribute index.
- The ROUTE selector operates only when there are no called digits in either the CDN or keypad IE, and is typically used as the second of two sets of translations data. The first set, with selector XLA, provides a translator to be used when there are called digits. The second set, with selector ROUTE, provides a route to follow when there are no digits.

If neither the ROUTE nor the LINEATTR selector is datafilled, and there are no called digits, the call is routed to permanent signal treatment.

The following shows an illustration of XLAMAP selectors.

### XLAMAP selectors

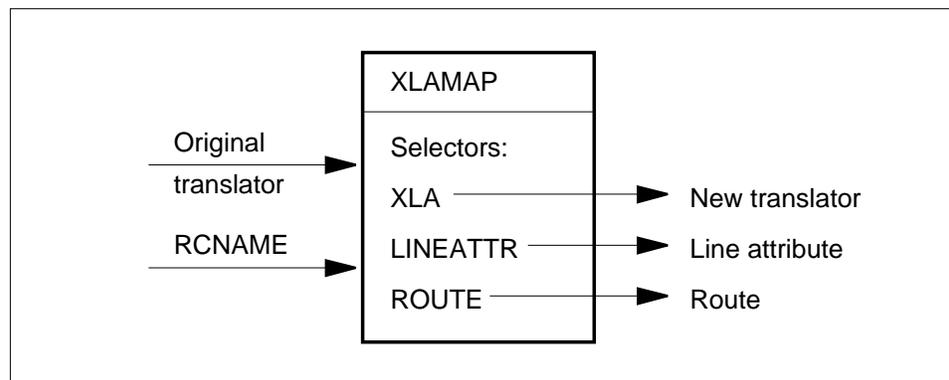

**Note:** The ROUTE and LINEATTR selectors do not support billing.

## PRI Bearer Capability Routing (continued)

The following table shows datafill descriptions for table XLAMAP.

### Datafilling table XLAMAP (Sheet 1 of 2)

Field	Subfield or refinement	Entry	Explanation and action
XLAKEY		see subfields	Translations key. Datafill the subfields RCNAME and XLANAME as one concatenated entry. Separate the two values with a blank. You are not prompted for the subfields individually.
	RCNAME	alphanumeric (1 to 8 characters)	Routing characteristics name. Enter the name from table RCNAME associated with the call.  <b>Note:</b> The default routing characteristic name cannot be used.
	XLANAME	alphanumeric (1 to 8 characters)	Translator name. Enter the original MDC translator name from table NCOS or CUSTHEAD.  <b>Note:</b> The XLANAME entry must be defined in table XLANAME.
DATA		see subfields	Data. There can be up to two DATA entries per tuple. A tuple ends automatically after a second entry.
	SEL	XLA, LINEATTR, ROUTE or \$	Selector. The new translations pointer. Enter one of the following values: <ul style="list-style-type: none"> <li>• Enter XLA for a translator name.</li> <li>• Enter LINEATTR for a line attribute.</li> <li>• Enter ROUTE for a route index.</li> <li>• Enter a \$ to end the tuple.</li> </ul> <b>Note:</b> Only XLA and ROUTE can be combined in one tuple.
	NEWXLA	alphanumeric	New translator. Enter the new translator to be used in table IBNXLA.  <b>Note:</b> Used when subfield SEL is XLA.  The NEWXLA entry must be defined in table XLANAME.

## PRI Bearer Capability Routing (continued)

### Datafilling table XLAMAP (Sheet 2 of 2)

Field	Subfield or refinement	Entry	Explanation and action
DATA (continued)	LINEATTR	0 to 2047	Line attribute. Enter a number from 0 to 2047 for the line attribute index. The line attribute index must be defined in table LINEATTR.  <b>Note:</b> Used when subfield SEL is LINEATTR.
	EXTRTEID		External route identification. Datafill the subfields TABID and KEY as one concatenated entry. Separate the two values with a blank. You are not prompted for the subfields individually.  <b>Note:</b> Used when subfield SEL is ROUTE.
	TABID	OFRT or IBNRTE	Table identifier. Enter OFRT or IBNRTE for the routing table.  <b>Note:</b> Used when subfield SEL is ROUTE.
	KEY	0 to 1023	Key. Enter a number from 0 to 1023 for the routing index in table OFRT or IBNRTE.  <b>Note:</b> Used when subfield SEL is ROUTE.

### Datafill example for table XLAMAP

The following example shows sample datafill for table XLAMAP. This tuple provides two sets of translations data: a translator name for table IBNXLA, and a route to follow when there are no digits.

### MAP display example for table XLAMAP

XLAKEY	DATA
64KRTE	ISAXLA ( XLA 64KCXDK)( ROUTE OFRT 25)\$

## PRI Bearer Capability Routing (continued)

### Error messages for table XLAMAP

The following error messages apply to table XLAMAP.

#### Error messages for table XLAMAP

Error message	Explanation and action
THE DEFAULT ROUTING CHARACTERISTIC NAME CANNOT BE DATAFILLED	The default routing characteristic name cannot be entered in subfield RCNAME. Use a different RCNAME when datafilling field XLAKEY.
ONLY ONE ROUTE OR LINEATTR OPTION ALLOWED PER TUPLE.	Only one ROUTE or LINEATTR value in subfield SEL can be datafilled in a tuple.  Enter each in separate tuples.
ONLY ONE XLA OR LINEATTR OPTION ALLOWED PER TUPLE.	Only one XLA or LINEATTR value in subfield SEL can be datafilled in a tuple.  Enter each in separate tuples.

### Datafilling table PXLAMAP

The following table shows the datafill specific to PRI Bearer Capability Routing for table PXLAMAP. Only those fields that apply directly to PRI Bearer Capability Routing are shown. For a description of the other fields, refer to the data schema section of this document.

Table PXLAMAP is a pretranslation table used for public calls which associates the original pretranslator name and the call's RCNAME with a new pretranslator name, an operator position, or a routing index. Two sets of new translations data can be associated with each original pretranslator and RCNAME.

As shown in the following figure "PXLAMAP selectors", three selectors in subfield SEL determine the next stage of translations for the call:

- The XLA selector provides a new pretranslator name to be used in table STDPRTCT.
- The POSITION selector provides an operator position.
- The ROUTE selector operates only when there are no called digits in either the CDN or keypad IE, and is typically used as the second of two sets of translations data. The first set, with selector XLA, provides a translator to be used when there are called digits. The second set, with selector ROUTE, provides a route to follow when there are no digits.



## PRI Bearer Capability Routing (continued)

If neither the ROUTE nor the POSITION selector is datafilled, and there are no called digits, the call is routed to permanent signal treatment.

### PXLAMAP selectors

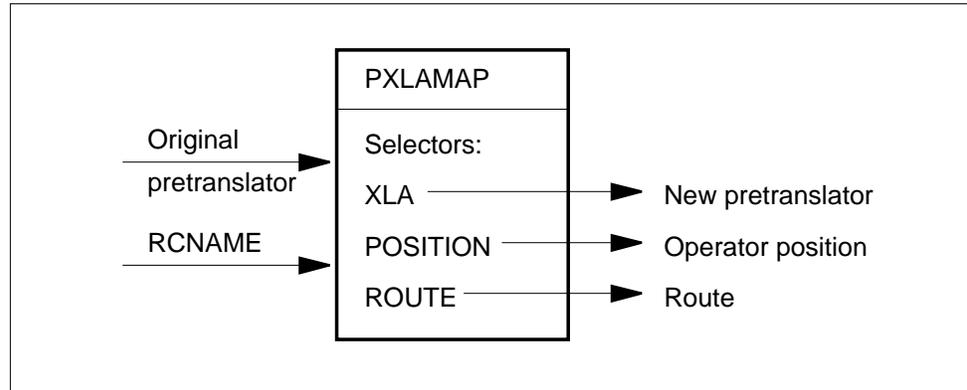

**Note:** The ROUTE and LINEATTR selectors do not support billing.

The following table shows descriptions of fields in table PXLAMAP.

### Datafilling table PXLAMAP (Sheet 1 of 2)

Field	Subfield or refinement	Entry	Explanation and action
PXLAKEY		see subfields	Translations key. Datafill the subfields RCNAME and XLANAME as one concatenated entry. Separate the two values with a blank. You are not prompted for the subfields individually.
	RCNAME	alphanumeric (1 to 8 characters)	Routing characteristics name. Enter the name from table RCNAME associated with the call. <b>Note:</b> The default routing characteristic name cannot be used.
	XLANAME	alphanumeric (1 to 4 characters)	Translator name. Enter the original pretranslator name from table XLANAME.
DATA		see subfields	Data. There can be up to two DATA entries per tuple. A tuple ends automatically after a second entry.

## PRI Bearer Capability Routing (continued)

### Datafilling table PXLAMAP (Sheet 2 of 2)

Field	Subfield or refinement	Entry	Explanation and action
	SEL	XLA, POSITION, ROUTE or \$	<p>Selector. A new pretranslations pointer. Enter one of the following values:</p> <ul style="list-style-type: none"> <li>• Enter XLA for a translator name.</li> <li>• Enter POSITION for an operator position.</li> <li>• Enter ROUTE for a route index.</li> <li>• Enter a \$ to end the tuple.</li> </ul> <p><b>Note:</b> The XLA and ROUTE, or XLA and POSITION can be combined in one tuple.</p>
	NEWXLA	alphanumeric	<p>New translator. Enter the new translator to be used in table IBNXLA.</p> <p><b>Note:</b> Used when subfield SEL is XLA.</p> <p>The NEWXLA entry must be defined in table XLANAME.</p>
	POS	TOPS,CTOP, CAMA,TSPS, AMRX,RTE1, RTE2,RTE3, RTE4,AOSS, OCC, or NONE	<p>Position. Enter one of TOPS, CTOP, CAMA, TSPS, AMRX, RTE1, RTE2, RTE3, RTE4, AOSS, OCC, or NONE to define an operator position.</p>
	TABID	OFTR or IBNRTE	<p>Table identifier. Enter OFRT or IBNRTE for the routing table.</p> <p><b>Note:</b> Used when subfield SEL is ROUTE.</p>
	KEY	0 to 1023	<p>Key. Enter a number from 0 to 1023 for the routing index in table OFRT or IBNRTE.</p> <p><b>Note:</b> Used when subfield SEL is ROUTE.</p>

### Datafill example for table PXLAMAP

The following example shows sample datafill for table PXLAMAP. This tuple provides two sets of translations data: a pretranslator name for table STDPRTCT, and a route to follow when there are no digits.

---

## PRI Bearer Capability Routing (continued)

---

### MAP display example for table PXLAMAP

PXLAKKEY	DATA
64KRTE PRAXLA	( XLA P625)( ROUTE OFRT 25)\$

### Error messages for table PXLAMAP

The following error messages apply to table PXLAMAP.

#### Error messages for table PXLAMAP

Error message	Explanation and action
THE DEFAULT ROUTING CHARACTERISTIC NAME CANNOT BE DATAFILLED.	The default routing characteristic name cannot be entered in subfield RCNAME. Use a different RCNAME when datafilling field PXLAKKEY.
ONLY ONE ROUTE OR POSITION OPTION ALLOWED PER TUPLE.	Only one ROUTE or POSITION value in subfield SEL can be datafilled in a tuple.  Enter each in separate tuples.

### Datafilling table IBNXLA

The following table shows the datafill specific to PRI Bearer Capability Routing for table IBNXLA. Only those fields that apply directly to PRI Bearer Capability Routing are shown. For a description of the other fields, refer to the data schema section of this document.

## PRI Bearer Capability Routing (continued)

Table IBNXLA provides translator tuples which allow the operating company to datafill a retranslation based on the RCNAME. The RC option in the REPL retranslation selector is datafilled for this purpose.

### Datafilling table IBNXLA

Field	Subfield or refinement	Entry	Explanation and action
KEY		see subfields	Key field. Datafill the subfields XLANAME and DGLIDX as one concatenated entry. Separate the two values with a blank. You are not prompted for the subfields individually.
	XLANAME	alphanumeric (1 to 8 characters)	Translator name. Enter the original translator name from table XLANAME.
	DGLIDX	vector of up to 18 digits	Digilator index. Enter up to 18 digits to be replaced.
RESULT		see subfields	Result
	TRSEL	REPL	Translator selector. Enter REPL for replace.
	CONTINUE	Y or N	Continue. Enter Y if translations are to continue with the next translator in the normal sequence. Enter N if translations are to restart from the beginning based on the user's NCOS and customer translator (as if the customer has dialed the replacement digits).
	REPLCODE	numeric (up to 16 digits)	Replacement code Enter up to 16 digits for the replacement digits.
	OPTION	RC	Option. Enter RC to indicate that retranslation is to be based on an RCNAME.
	RCNAME	alphanumeric (1 to 8 characters)	Routing characteristics name. Enter a name from table RCNAME.

### Datafill example for table IBNXLA

The following example shows sample datafill for table IBNXLA.

---

**PRI Bearer Capability Routing** (continued)
 

---

**MAP display example for table IBNXLA**

KEY		RESULT	
CXDK	765	REPL N	365 ( RC 64KRTE)\$

**Error messages for table IBNXLA**

Not applicable

**Datafilling table LTCALLS**

The following table shows the datafill specific to PRI Bearer Capability Routing for table LTCALLS. Only those fields that apply directly to PRI Bearer Capability Routing are shown. For a description of the other fields, refer to the data schema section of this document.

Table LTCALLS provides initial translations for the calls that can be routed over the trunk group. The table is datafilled with the trunk group's LTID, the call type, and the initial translations route for calls

**Datafilling table LTCALLS (Sheet 1 of 3)**

Field	Subfield or refinement	Entry	Explanation and action
LTID		see subfields	Logical terminal identifier. Datafill subfields LTGRP, LTNUM, and CALLTYP as one concatenated entry. Separate the three values with blanks. You are not prompted for the subfields individually.
	LTGNUM	see subfields	Logical terminal group number. This is made up of subfields LTGRP and LTNUM.
	LTGRP	alphanumeric (up to 8 characters)	Logical terminal group. Enter the trunk group name from table LTDEF.
LTID (continued)	LTNUM	1 to 1022	Logical terminal number. Enter the trunk group number from table LTDEF.

## PRI Bearer Capability Routing (continued)

### Datafilling table LTCALLS (Sheet 2 of 3)

Field	Subfield or refinement	Entry	Explanation and action
XLARTSEL	CALLTYP	PUB or PVT	Call type. Enter PUB for public. Enter PVT for private.
		see subfields	Translation route selector
	XLARTE	XLAIBN, XLALEC or RTEREF	Translation route. Enter one of the following values: <ul style="list-style-type: none"> <li>• XLAIBN for integrated business network for PBX or MDC type offices.</li> <li>• XLALEC for local exchange carrier for POTS, PBX, or MDC type offices.</li> <li>• RTEREF to route the call to the appropriate table.</li> </ul> <p><b>Note:</b> The XLAREC selector cannot be used when field CALLTYPE is PVT.</p>
	LINEATTR	0 to 2047	Line attribute. Enter a number from 0 to 2047 for the index into table LINEATTR. <p><b>Note:</b> Only use when field XLARTE is XLAIBN or XLALEC.</p>
	CUSTGRP	alphanumeric	Customer group name. Enter the customer group name. <p><b>Note:</b> Only use when field XLARTE is XLAIBN.</p>
	SUBGRP	0 to 7	Subgroup. Enter a number from 0 to 7 for the customer subgroup. <p><b>Note:</b> Only use when field XLARTE is XLAIBN.</p>
	NCOS	0 to 511	Network class of service. Enter a number from 0 to 511 for the key to the NCOS table. <p><b>Note:</b> Only use when field XLARTE is XLAIBN.</p>

---

## PRI Bearer Capability Routing (continued)

---

### Datafilling table LTCALLS (Sheet 3 of 3)

Field	Subfield or refinement	Entry	Explanation and action
XLARTSEL (continued)	TABNAME	OFTR or IBNRTE	Table name. Enter OFRT or IBNRTE for the routing table.  <b>Note:</b> Only use when field XLARTE is RTEREF.
	INDEX	0 to 1023	Index. Enter a number from 0 to 1023 for the extended route reference index.  <b>Note:</b> Only use when field XLARTE is RTEREF.

### Datafill example for table LTCALLS

The following example shows sample datafill for table LTCALLS.

### MAP display example for table LTCALLS

LTID			XLARTSEL			OPTIONS
ISDN	1008	PVT	RTEREF	OFRT	100	\$

### Error messages for table LTCALLS

Not applicable

### Datafilling table TRKRCSEL

The following table shows the datafill specific to PRI Bearer Capability Routing for table TRKRCSEL. Only those fields that apply directly to PRI

## PRI Bearer Capability Routing (continued)

Bearer Capability Routing are shown. For a description of the other fields, refer to the data schema section of this document.

### Datafilling table TRKRCSEL

Field	Subfield or refinement	Entry	Explanation and action
GRPKEY		alphabetic	Group key. Enter the trunk group name defined in table CLLI.
RCFILTER		see subfields	Routing characteristics filter. This field consists of subfields RCSELR and RCSEL. The maximum number of multiples available for this field is the same as the number of different routing characteristics available in the switch.
	RCSELR	BC, OSA, CDB, TNS, SR, PI	Routing characteristic selector. Enter the particular routing characteristic the end user wants to turn on or off.
	RCSEL (see note)	ON, OFF	Routing characteristic selector. Enter ON to turn on the routing characteristic specified in field RCSELR. When ON is specified, that particular routing characteristic is used for translation.

**Note:** BC is defaulted on. All others are defaulted off. The default value is applicable to those routing characteristics that are not specified.

### Datafill example for table TRKRCSEL

The following example shows sample datafill for table TRKRCSEL.

### MAP display example for table TRKRCSEL

GRPKEY	RCFILTER
PRITRK	(BC ON) (CDN OFF) (TNS OFF) (OSA OFF) \$



---

## PRI Bearer Capability Routing (continued)

---

### Error messages for table TRKRCSEL

The following error messages apply to table TRKRCSEL.

#### Error messages for table TRKRCSEL

Error message	Explanation and action
This table only supports PRI trunks	A filter was defined for non-PRI trunks. Define filters only for PRI trunks.
***ERROR - Must be 2W or INCOMING trunk	The trunk specified is not a 2W or INCOMING trunk. Specify trunks as 2W or incoming.

### Datafilling table RTECHAR

The following table shows the datafill specific to PRI Bearer Capability Routing for table RTECHAR. Only those fields that apply directly to PRI Bearer Capability Routing are shown. For a description of the other fields, refer to the data schema section of this document.

Table RTECHAR defines an RCNAME by assigning it a set of routing characteristics. For each RCNAME, up to seven sets of routing characteristics can be listed.

The table permits call routing based on the transmission service identified by BCNAMEs.

#### Datafilling table RTECHAR (Sheet 1 of 2)

Field	Subfield or refinement	Entry	Explanation and action
RCKEY		see subfield	Routing characteristics key. Datafill subfield RCNAME. You are not prompted for the subfield individually.
	RCNAME	alphanumeric (1 to 8 characters)	Routing characteristic name Enter a name from table RCNAME.  <b>Note:</b> The default routing characteristic name cannot be used.

## PRI Bearer Capability Routing (continued)

### Datafilling table RTECHAR (Sheet 2 of 2)

Field	Subfield or refinement	Entry	Explanation and action
GROUPRC		see subfields	Routing characteristics groupings. Datafill subfields RCSEL and BCNAME as one concatenated entry. Separate the two values with a blank. End the entry with a blank and a \$. You are not prompted for the subfields individually. Up to seven GROUPRC values can be assigned to each RCKEY. The tuple automatically ends after a seventh value. Enter a \$ to end the tuple.
	FIRSTRC	alphanumeric	First routing characteristic group. This is made up of subfields RCSEL and BCNAME. Only one FIRSTRC can be assigned within a GROUPRC.
	RCSEL	BC, CDN, OSA, PI, SR, or TNS	Routing characteristic selector. Enter one of the entries with its respective refinements. Enter BC and datafill refinement BC. Enter CDN and datafill refinement CDNTON. Enter OSA and datafill refinement OSA. Enter PI and datafill refinement PI. Enter SR and datafill refinement SR. Enter TNS and datafill refinement TNSTON.
	BCNAME	alphanumeric	Bearer capability name Enter the BC name from table BCDEF applicable to this set of routing characteristics.

### Datafill example for table RTECHAR

The following example shows sample datafill for table RTECHAR. The tuple defines RCNAME 64KDATA, which allows routing based on a transmission type of 64-kit/s data identified by BCNAME 64KDATA.

---

## PRI Bearer Capability Routing (continued)

---

### MAP display example for table RTECHAR

RCKEY	GROUPRC
64KRTE (BC 64KDATA (OSA NIL) (CDN NIL) (TNS NIL) \$) \$	

### Error messages for table RTECHAR

The following error messages apply to table RTECHAR.

#### Error messages for table RTECHAR

Error message	Explanation and action
AT LEAST ONE GROUP OF ROUTING CHARACTERISTICS MUST BE PRESENT	A tuple has no value for field GROUPRC. Enter a routing characteristic in field GROUPRC.
NILNAME CANNOT BE USED IN THIS TABLE	The default RCNAME cannot be used in field RCKEY. Use another name.

### Translation verification tools

The following five examples show TRAVER outputs for a private terminating call, a public terminating call, a private originating call, and a public originating call.

*Note:* Some messages and table accesses that do not relate directly to the capability have been removed from the TRAVER examples, so that it is easier to follow the progression through main routing tables.

#### Private terminating call

The following example shows the output from TRAVER when it is used to verify PRI Bearer Capability Routing for a private call terminating in the DMS-100.

In a simulation, the TRAVER command replaces the SETUP message that the DMS-100 would receive in a real situation, and provides all the information

**PRI Bearer Capability Routing** (continued)

---

normally contained in the SETUP message. In the TRAVER command shown at the top of the example.

- tr indicates that a trunk name follows, and bnrpraic is the trunk name
- n replaces the called digits which would be entered here for a non-ISDN call simulation
- cdn indicates that CDN IE information follows, which includes pvt and 55982 in this case
- pvt (private) is the NPI, and 55982 represents the digits
- prvt is the NSF
- bc indicates that a BC IE follows, and 56kdata is the bearer capability
- b indicates that the type of trace required is "both," meaning that both a table trace and a digit trace are to be performed.

The routing process shown in the TRAVER example is as follows:

1. In lines 1 and 2 of the example, table RTECHAR is accessed with the transmission characteristics from the SETUP message, which are defined by the RCNAME 56KDATA.
2. In lines 3 and 4, table TRKGRP is accessed with the trunk group CLLI, BNRPRAIC, and provides the trunk group LTID, ISDN 501.
3. In lines 5 and 6, the LTID and the call type derived from the SETUP message, PVT, are used to access table LTCALLS, which provides the customer group name, IBNTST, and the NCOS, 0.
4. The customer group name is used to search for a translator name for the customer group. First, in lines 7 and 8, table NCOS is accessed with the customer group name and the NCOS, but it doesn't contain a translator. Table CUSTHEAD (lines 9 and 10), however, does provide a customer group translator, CXT3, which is used to access table XLAMAP.
5. In lines 11 and 12, table XLAMAP is accessed with the RCNAME, 56KDATA, and the translator from table CUSTHEAD, CXT3, and provides a new translator, XLAT.
6. In lines 13 and 14, the new translator and the dialed digits are used to access table IBNXLA. The tuple in IBNXLA contains selector EXTN (extension), which provides the SNPA and central office code used to key into tables TOFCNAME, DNINV, and DNATTRS, the process continuing with standard translations.

The following is a TRAVER output example for PRI Bearer Capability Routing for a private terminating call.



**PRI Bearer Capability Routing** (continued)

---

normally contained in the SETUP message. In the TRAVER command shown at the top of the example.

- tr indicates that a trunk name follows, and bnrpraic is the trunk name
- n replaces the called digits which would be entered here for a non-ISDN call simulation
- cdn indicates that CDN IE information follows, which includes e164 and 4015213 in this case
- e164 (public) is the NPI, and 4015213 represents the digits
- bc indicates that a BC IE follows, and 56kdata is the bearer capability
- b indicates that the type of trace required is "both," meaning that both a table trace and a digit trace are to be performed.

The routing process shown in the TRAVER example is as follows:

1. In lines 1 and 2 of the example, table RTECHAR is accessed with the transmission characteristics from the SETUP message, which are defined by the RCNAME 56KDATA.
2. In lines 3 and 4, table TRKGRP is accessed with the trunk group CLLI, BNRPRAIC, and provides the trunk group LTID, ISDN 501.
3. In lines 5 and 6, the LTID and the call type derived from the SETUP message, PUB, are used to access table LTCALLS, which provides the index to table LINEATTR, 12.
4. In lines 7 and 8, table LINEATTR is accessed with the index from table LTCALLS. In lines 9 and 10, the standard pretranslator name from table LINEATTR, P600, is used to access table PXLAMAP, which provides a new pretranslator for ISDN calls, P621.
5. The new pretranslator, P621, is used to access table STDPRTCT in lines 11 and 12, and standard translations follow until a route reference, 401, is obtained in line 18.
6. In lines 19 and 20, the call's BC value and the route reference, 401, are used to access mapping table RTEMAP, which provides a new route index for ISDN calls, 402.
7. In lines 21 and 22, table RTEREF is accessed with the new index.

The following is a TRAVER output example for PRI Bearer Capability Routing for a public terminating call.



**PRI Bearer Capability Routing** (continued)

---

the information normally contained in the SETUP message. In the TRAVER command shown at the top of the example.

- l indicates that the DN of the originating line follows, and 6215982 is the DN
- n replaces the called digits which would be entered here for a non-ISDN call simulation
- cdn indicates that CDN IE information follows, which includes pvt and 15983 in this case
- pvt (private) is the call type, and 15982 represents the digits
- prvt is the NSF
- bc indicates that a BC IE follows, and 56kdata is the bearer capability
- b indicates that the type of trace required is "both," meaning that both a table trace and a digit trace are to be performed.

The routing process shown in the TRAVER example is as follows:

1. In lines 1 and 2 of the example, table RTECHAR is accessed with the transmission characteristics in the SETUP message from the terminal, which are defined by the RCNAME 56KDATA.
2. In lines 3 and 4, table KSETLINE is accessed to begin the translations of the call. The NPA and calling number from table KSETLINE are used to access table DNATTRS to check for any restrictions or subscription parameters.
3. In lines 7 to 10, tables NCOS and CUSTHEAD are accessed with the customer group name, IBNTST, from table KSETLINE, to find a translator name. The customer group translator from table CUSTHEAD, CXT3, is used to access table XLAMAP. In lines 11 and 12, the digit collection index from table CUSTHEAD is used to access table DIGCOL, which defines the number of digits to collect for this customer group.
4. In lines 13 and 14, table XLAMAP is accessed with the customer group translator from CUSTHEAD, CXT3, and the RCNAME associated with the call, 56KDATA. XLAMAP provides a new translator, CXT2, which is used to access IBNXLA.
5. In lines 15 and 16, table IBNXLA provides a route index to table IBNRTE, 800, but as there is a bearer capability associated with the call, table IBNMAP is accessed first.
6. In lines 19 and 20, table IBNRTE is accessed with the new routing index from IBNMAP, 700, and provides a trunk group CLI for the call BNRPRAOG. Because the ISA selector is used in table IBNRTE, the NPI



---

## PRI Bearer Capability Routing (continued)

---

(PVT) and NSF (PRVT) are specified for inclusion in the SETUP message.

7. In lines 21 and 22, table TRKGRP is accessed with the trunk group CLLI, and provides the LTID of the trunk group, ISDN 500, which is used to key into table LTCALLS.
8. The LTID and the call type (PVT) from table IBNRTE are used to find a tuple in table LTCALLS, which allows the call to go through to the trunk.
9. In lines 25 and 26, table DIGMAN is accessed with the digit manipulation index from table IBNRTE, 15, to obtain the prefix 401, which must be outpulsed before the digits.
10. Line 35 shows the information to be included in the SETUP message generated with the call:
  - CDN specifies that a CDN IE is to be generated
  - PVT is the NPI
  - L indicates that the type of number is local
  - 4015983 is the called number
  - PRVT is the NSF
  - 0 indicates that there is no facility number identified (as there could be for a FX or TIE call)
  - BC 56KDATA indicates that the BC IE will contain the BC value 56KDATA

The following is a TRAVER output example for PRI Bearer Capability Routing for a private originating call.

## PRI Bearer Capability Routing (continued)

### TRAVER output example for PRI Bearer Capability Routing private originating call

Line	Output
	<b>&gt;traver I 6215982 n cdn pvt 15983 prvt bc 56kdata b</b>
1	TABLE RTECHAR
2	. 56KDATA ( BC 56KDATA \$)\$
3	TABLE KSETLINE
4	WITS 2 1 DN Y 6215982 IBNTST 0 0 613 (RAG) (LNR) (SFC) (CFX) \$
5	TABLE DNATTRS
6	613 621 5982 (PUBLIC ( NAME WITS_2) \$)\$ \$
7	TABLE NCOS
8	IBNTST 0 0 0 TST10 (XLAS CXT1 RXCFN NDGT) (OHQ 0 TONE_OHQ) (CBQ 0 1 Y 2)
9	TABLE CUSTHEAD: CUSTGRP, PRELIMXLA, CUSTXLA, FEATXLA, VACTRMT, AND DIGCOL
10	IBNTST NXLA CXT3 RXCFN 0 TST1
11	TABLE DIGCOL
12	TST1 1 COL S 2
13	TABLE XLAMAP
14	. 56KDATA CXT3 ( XLA CXT2) \$
15	TABLE IBNXLA: XLANAME CXT2
16	CXT2 1 ROUTE N Y N 1 N 2 18 POTS N T IBNRTE 800
17	TABLE IBNMAP
18	. 56KDATA 800 700
19	TABLE IBNRTE
20	700 ISA N N N BNRPRAOG PVT 0 PVT 15
21	. TABLE TRKGRP
22	. BNRPRAOG PRA 0 PRAC NCRT ASEQ N (ISDN 500) \$ \$
23	. TABLE LTCALLS
24	. ISDN 500 PVT XLAIBN 0 IBNTST 0 0 \$
25	. TABLE DIGMAN
26	. 15 (INC 401)
27	. EXIT TABLE DIGMAN
28	EXIT TABLE IBNRTE
29	
30	+++ TRAVER:SUCCESSFUL CALL TRACE+++
31	
32	
33	DIGIT TRANSLATION ROUTES
34	
35	1 BNRPRAOG                    N CDN PVT L 4015983 PRVT 0 BC 56KDATA
36	
37	TREATMENT ROUTES. TREATMENT IS: GNCT
38	1 T120
39	
40	+++ TRAVER: SUCCESSFUL CALL TRACE +++

### Public originating call

The following example shows the output from TRAVER when it is used to verify PRI Bearer Capability Routing for a public call originating in the DMS-100.

---

## PRI Bearer Capability Routing (continued)

---

In a simulation, the TRAVER command replaces the SETUP message that the DMS-100 would receive from the terminal in a real situation, and provides all the information normally contained in the SETUP message. In the TRAVER command shown at the top of the example

- l indicates that the DN of the originating line follows, and 6215982 is the DN
- n replaces the called digits which would be entered here for a non-ISDN call simulation
- cdn indicates that CDN IE information follows, which includes e164 and 96605983 in this case
- e164 (public) is the NPI, and 96605983 represents the digits
- bc indicates that a BC IE follows, and 56kdata is the bearer capability
- b indicates that the type of trace required is "both," meaning that both a table trace and a digit trace are to be performed.

The routing process shown in the TRAVER example is as follows:

1. In lines 1 and 2 of the example, table RTECHAR is accessed with the transmission characteristics in the SETUP message from the terminal, which are defined by the RCNAME 56KDATA.
2. In lines 3 and 4, table KSETLINE is accessed to begin the translations of the call. The NPA and calling number from table KSETLINE are used to access table DNATTRS to check for any restrictions or subscription parameters.
3. In lines 7 to 10, tables NCOS and CUSTHEAD are accessed with the customer group name, IBNTST, from table KSETLINE, to find a translator name. The customer group translator from table CUSTHEAD, CXT3, is used to access table XLAMAP. In lines 11 and 12, the digit collection index from table CUSTHEAD is used to access table DIGCOL, which indicates that POTS digit collection is required.
4. In lines 13 and 14, table XLAMAP is accessed with the customer group translator from CUSTHEAD, CXT3, and the RCNAME associated with the call, 56KDATA. Table XLAMAP provides a line attribute index, 22, which is used to access table LINEATTR.
5. In lines 15 and 16, table LINEATTR provides a standard pretranslator index to table STDPRTCT, P601, but as there is a bearer capability associated with the call, table PXLAMAP is accessed first, and provides a new pretranslator, P621.

**PRI Bearer Capability Routing** (continued)

---

6. In lines 17 and 18, table PXLAMAP is accessed using 56KDATA as the key.
7. In lines 19 to 26, table STDPRTCT is accessed with the new standard pretranslator from PXLAMAP and the first two digits of the called number, and standard translations follow until a routing index to table RTEREF, 13, is obtained.
8. Because there is a bearer capability associated with the call, table RTEMAP is accessed before table RTEREF, with the routing index from HNPACODE, 13, and the RCNAME. Table RTEMAP provides a new routing index to table RTEREF, 710, which provides a trunk group CLLI for the call, BNRPRAOG. Because the ISA selector is used in table RTEREF, the NPI (PUB) is specified for inclusion in the SETUP message.
9. In lines 31 and 32, table TRKGRP is accessed with the trunk group CLLI, and provides the LTID of the trunk group, ISDN 201, which is used to key into table LTCALLS.
10. The LTID and the call type (PUB) from table RTEREF are used to find a tuple in table LTCALLS, which allows the call to go through to the trunk.
11. In lines 35 and 36, table DIGMAN is accessed with the digit manipulation index from table IBNRTE, 20, which specifies that the first three digits must be removed and replaced with the digits 401 before the number is outpulsed.
12. Line 45 shows the information to be included in the SETUP message generated with the call:
  - CDN specifies that a CDN IE is to be generated
  - E164 is the NPI
  - L indicates that the type of number is local
  - 4015983 is the called number
  - NIL\_NSF indicates that there is no NSF, as it is a public call
  - BC 56KDATA indicates that the BC IE will contain the BC value 56KDATA.

The following is a TRAVER output example for PRI Bearer Capability Routing for a public originating call.

## PRI Bearer Capability Routing (continued)

### TRAVER output example for PRI Bearer Capability Routing public originating call

```

Line   Output
>traver I 6215982 n cdn e164 96605983 bc 56kdata b
1      TABLE RTECHAR
2      . 56KDATA ( BC 56KDATA $)$
3      TABLE KSETLINE
4      WITS 2 1 DN Y 6215982 IBNTST 0 0 613 (RAG) (LNR) (SFC) (CFX) $
5      TABLE DNATTRS
6      613 621 5982
       (PUBLIC ( NAME WITS_2) $)$ $
7      TABLE NCOS
8      IBNTST 0 0 0 TST10 (XLAS CXT1 RXCFN NDTG) (OHQ 0 TONE_OHQ) (CBQ 0 1 Y 2)
9      TABLE CUSTHEAD: CUSTGRP, PRELIMXLA, CUSTXLA, FEATXLA, VACTRMT, AND DIGCOL
10     IBNTST NXLA CXT3 RXCFN 0 TST1
11     TABLE DIGCOL
12     TST1 9 POTS Y
13     TABLE XLAMAP
14     . 56KDATA CXT3 (LINEATTR 22) $
15     TABLE LINEATTR
16     22 1FR NONE NOT FR01 0 613 P601 L613 TSPTS 10 NIL NILSFC LATA1 NIL NIL NIL 00
17     TABLE PXLAMAP
18     . 56KDATA P601 ( XLA P621) $
19     TABLE STDPRTCT
20     P621 ( 1) ( 0) 0
21     . SUBTABLE STDPRT
22     . 66 69 N NP 0 NA
23     TABLE HNPACONT
24     613 710 2 ( 39) ( 1) ( 0) ( 2) 0
25     . SUBTABLE HNPACODE
26     . 660 660 LRTE 13
27     . SUBTABLE RTEMAP
28     . . 56KDATA 13 710
29     . SUBTABLE RTEREF
30     . 710 ISA N N N BNRPRAOG PUB NONE N N 20
31     . . TABLE TRKGRP
32     . . BNRPRAOG PRA 0 PRAC NCRT ASEQ N ( ISDN 201) $ $
33     . . TABLE LTCALLS
34     . . ISDN 201 PUB XLAIBN 0 IBNTST 0 0 $
35     TABLE DIGMAN
36     . . 20 (REM 3) (INC 401)
37     .. EXIT TABLE DIGMAN
38     . EXIT TABLE RTEREF
39     EXIT TABLE HNPACONT
40     +++ TRAVER: SUCCESSFUL CALL TRACE +++
41
42
43     DIGIT TRANSLATION ROUTES
44
45     1 BNRPRAOG           N CDN E164 L 4015983 NIL_NSF BC 56KDATA
46
47     TREATMENT ROUTES.  TREATMENT IS:  GNCT
48     1 T120

+++ TRAVER: SUCCESSFUL CALL TRACE +++

```

## PRI Bearer Capability Routing (continued)

---

In a simulation, the TRAVER command replaces the SETUP message that the DMS-100 would receive from the terminal in a real situation, and provides all the information normally contained in the SETUP message. In the TRAVER command shown at the top of the example.

- tr indicates that the name of the trunk follows, and pracmr1aic is the trunk name
- n replaces the called digits that would be entered here for a non-ISDN call simulation
- cdn indicates that CDN IE information follows, which in this case is na and 6137227050
- na (public) is the NPI, and 6137227050 represents the digits
- bc indicates that a BC IE follows, and 64kdata is the bearer capability
- b indicates that the type of trace required is "both," meaning that both a table trace and a digit trace are to be performed.

The routing process shown in the TRAVER example is as follows:

1. In lines 1 and 2 of the example, table TRKRCSEL is accessed with the trunk name and the routing characteristics.
2. In lines 3 and 4, table RTECHAR is accessed with the transmission characteristics in the SETUP message from the terminal, which are defined by the RCNAME 64KDATA. RCNAME 64KDATA is used because routing characteristic CDN was defined as being off and the bearer capability is 64KDATA.
3. In lines 5 to 8, table TRKGRP is accessed with the CLLI from the routing table, and provides the LTID assigned to the trunk. With the LTID and the call type (from the routing table), table LTCALLS is accessed. If a tuple is found in table LTCALLS for the LTID and call type, the call is allowed to go through to the trunk.
4. In lines 9 to 13, table LINEATTR provides a standard pretranslator index to table STDPRTCT, P621, but as there is a bearer capability associated with the call, table PXLAMAP is accessed first. Because no type is found in table PXLAMAP, the default pretranslator name is used.
5. In lines 14 to 29, table STDPRTCT is accessed with the standard pretranslator and standard translations follow until routing index is obtained from table HNPACONT.
6. In lines 30 and 31, table TOFCNAME is accessed with the area and office codes of the terminating office.

---

**PRI Bearer Capability Routing** (continued)

---

7. In lines 32 to 38, table DNINV is accessed with the assigned directory number, and table DNATTRS specifies the DN attributes from table DNGRPS.
8. In lines 39 to 44, table LCASCRCN is accessed with the NPA of the trunk group, the local calling area name, and the prefix selector. Table LCASCRCN determines that the call is a non-local call. Table PFXTREAT is then accessed with the OPTL prefix selector from table LCASCRCN.
9. In lines 45 and 46, table CLSVSCRC is accessed.
10. Line 50 shows the information to be included in the SETUP message generated with the call.

The following TRAVEL shows a PRI Bearer Capability Routing example of a public originating call.

## PRI Bearer Capability Routing (continued)

### TRAVER output example for PRI Bearer Capability Routing public originating call

Line	Output
	<b>&gt;traver tr pracmr1aic n cdn na 6137227050 bc 64kdata b</b>
1	TABLE TRKRCSEL
2	.PRACMR1AIC (CDN OFF)\$
3	TABLE RTECHAR
4	. 64KDATA (BC 64KDATA \$)\$
5	TABLE TRKGRP
6	PRACMR1AIC PRA 0 NPDGP NCRT DSEQ N (ISDN 565) \$ \$
7	TABLE LTCALLS
8	ISDN 565 PUB XLAIBN 600 COMKODAK 0 0 \$
9	TABLE LINEATTR
10	600 IBN NONE NT FR01 0 613 P621 L613 TSPS 0 NIL NILSFC NILLATA 0 NIL NIL 00 N \$
11	LCABILL OFF - BILLING DONE ON BASIS OF CALLTYPE
12	TABLE PXLAMAP
13	. Tuple not found. Default to old pretranslator name.
14	TABLE STDPRTCT
15	P621 ( 1) (65021) 0
16	. SUBTABLE STDPRT
17	WARNING: CHANGES IN TABLE STDPRT MAY ALTER OFFICE
18	BILLING. CALL TYPE DEFAULT IS NP. PLEASE REFER TO
19	DOCUMENTATION
20	. KEY NOT FOUND
21	. DEFAULT VALUE IS: N NP 0 NA
22	. SUBTABLE AMAPRT
23	. KEY NOT FOUND
24	. DEFAULT VALUE IS: NONE OVRNONE N
25	TABLE HNPACONT
26	613 984 1 ( 268) ( 1) ( 84) ( 0) 0
27	. SBUTABLE HNPACODE
28	. 613 613 HNPA 0
29	. 722 722 NPOSDN 613 722
30	TABLE TOFCNAME
31	613 722
32	TABLE DNINV
33	613 722 7050 MDN SCA 3
34	TABLE DNATTRS
35	613 722 7050
36	(PUBLIC (NONUNIQUE) \$)\$ \$ \$
37	TABLE DNGRPS
38	TUPLE NOT FOUND
39	TABLE LCASCRCN
40	613 L613 ( 13) OPTL N
41	. SUBTABLE LCASCR
42	. TUPLE NOT FOUND. DEFAULT IS NON-LOCAL
43	TABLE PFXTREAT
44	OPTL NP N DD UNDT
45	TABLE CLSVSCRC
46	KEY NOT FOUND
47	DEFAULT IS TO LEAVE XLA RESULT UNCHANGED
48	+++ TRAVER: SUCCESSFUL CALL TRACE +++
49	DIGIT TRANSLATION ROUTES
50	1 LINE 6137227050 ST
51	TREATMENT ROUTES. TREATMENT IS: GNCT
52	+++ TRAVER: SUCCESSFUL CALL TRACE +++



---

**PRI Bearer Capability Routing** (end)

---

**SERVORD**

PRI Bearer Capability Routing does not use SERVORD.

## PRI Call Routing

---

### Ordering codes

Functionality group ordering codes: NI000022, NI000011

Functionality ordering code: not applicable

### Release applicability

BCS36 and up

### Prerequisites

To operate, PRI Call Routing has the following prerequisites:

- NI0 ISDN Base, NI000007
- MDC–MDC Minimum, MDC00001

### Description

PRI Call Routing establishes the routing of calls over the PRI interface. A PRI call comes in to the DMS-100 switch over a PRI trunk from the switching node at the far end and is switched to a line or a PRI trunk.

Integrated services access (ISA) is the part of PRI Call Routing that allows different types of calls to be routed over the same PRI Trunk group. It is ISA that allows different call types to coexist on the same PRI trunk group. The following are the call types that are supported by ISA.

- **Public (PUB).** These calls connect the subscriber to the public switched telephone network (PSTN). With direct inward dialing (DID), public calls connect the central office DMS-100 switch to a private branch exchange (PBX) such as Meridian 1. With direct outward dialing (DOD), public calls connect the PBX with the DMS-100 switch. The dialed digits conform to E.164 standards.
- **Private (PVT).** These incoming and outgoing calls connect the PBX to its virtual private network (VPN). The DMS-100 switch makes use of the public network to support a private numbering plan. The dialed digits may not conform to E.164 standards.
- **OUTWATS (WATS).** Outward wide area telephone service is a service provided by the operating company that permits a subscriber to originate calls to a specific geographical area known as a zone or band. A flat monthly charge is provided for such services.
- **INWATS.** Inward wide area telephone service is a long distance service that allows a subscriber to receive telephone calls without a charge to the caller. the subscriber is billed for the call instead of he caller. A 1+code (such as 800) is assigned to the PBX to allow for this reversed billing.

---

## PRI Call Routing (continued)

---

- Foreign exchange (FX). Foreign exchange trunks connect a subscriber location to a remote exchange, the PBX users can submit calls to some distant point in the PSTN without incurring the normal public network charges. this service provides the equivalent of local service between the subscriber and the remote exchange.
- Tie line (TIE). Tie lines are dedicated leased-type network trunks used between network equipment.

The ISA feature sends the call type between switches by the Q.931 SETUP message. the call type determines the translations that is used to route an incoming call. the call type is significant only to the local PRI. Once inside the next exchange, it is discarded. Subsequent routes of the same call can use different call types.

The SETUP message contains information about the call. The following are the two information elements (IE) in the Q.931 SETUP message that are used for ISA incoming calls.

- Numbering plan indicator (NPI). The NPI is contained in the called party directory number (CDN) IE in the SETUP message. the NPI indicates whether the numbering plan used for the called number is public or private.
- Network specific facilities (NSF). The NSF indicates which network facilities are to be used for the call. Incoming calls can specify the type of service to access by means of the NSF.

The NSF information element contains the following information:

- a service selector that specifies the type of service requested
- an optional service identifier (SID) that specifies the actual facility to use to route the call. INWATS ISA calls can be routed on the SID for all call types except public.

For PRI TO PRI calls, the NSF information is in both the originating and terminating IE. This information is PRI specific and can be different on each PRI.

For non-PRI to PRI calls, the NSF information is not in the originating IE, but is obtained from the ISA selector in the routing tables. If ISA is not used as the routing selector, then no NSF is generated for the terminator.

### Operation

When the DMS-100 switch receives a call over the PRI, the trunk group LTID in table TRKGRP is used to access table LTCALLS, which provides the initial information for translating the call.

## **PRI Call Routing** (continued)

---

The NCOS code and the customer group name from table LTCALLS are used to access table NCOS and CUSTHEAD for a translator name. If there is no customer group translator in table NCOS, table CUSTHEAD provides the default translator. The translator is used to access table IBNXLA, which provides the routing index for standard translations.

DID operates by enabling or disabling the CDN in the SETUP message in table LTDATA. Table LTDATA delivers the CDN to the switching node at the far end.

### **Call processing 0+ and 1+ called numbers for National ISDN PRI**

Prior to the NA012 software release, the DMS-100 switch blocked calls that contained a leading digit of 0 or 1 in the Called Party Number parameter and the type of number was coded as National Number or Local Number. The NA012 software release allows these types of calls as described in the following paragraphs.

If the type of number is coded as National or Local and the first digit is 0, the DMS-100 switch interprets the digit 0 as a request for an operator. The DMS-100 switch sends the remaining digits forward to assist the operator system in determining the called party.

If the type of number is coded as National and the first digit is 1, the DMS-100 switch interprets the digit 1 as a single digit prefix and deletes the digit 1. The DMS-100 switch uses the remaining digits to determine the called party through basic called number analysis. If required, the system sends the remaining digits to translations.

If the type of number is coded as Local and the first digit is 1, the DMS-100 switch interprets the digit 1 as a single digit prefix and deletes the digit 1. The DMS-100 switch uses the remaining digits to determine the called party and sends the digits to translations.

With this change, the DMS-100 switch continues to accept 7-digit local and 10-digit national numbers that do not have a leading digit 1. This functionality only works for an ISDN numbering plan. Within this plan, additional validation/transformation is applied to the called party number.

---

**PRI Call Routing** (continued)

---

The following table describes possible transformations.

**Examples of possible transformations**

Type of number	Original CDN	Number passed to translations
Local or National	0 X...X	0 X...X
	N11 Z...Z	N11
	1 N11 Z...Z	N11
Local	NXX XXXX Z...Z	NXX XXXX
	1 NXX XXXX Z...Z	NXX XXXX
National	NXX NXX XXXX Z...Z	NXX NXX XXXX
	1 NXX NXX XXXX Z...Z	NXX NXX XXXX
International	N Y...Y Z...Z	N Y...Y
<p><b>Note:</b> Y...Y contains 6–14 digits. If Y...Y contains less than 14 digits, then Z...Z is empty.</p>		
<p>Legend:  X = any digit  Y = any digit  Z = any digit  N = digits 2–9  A = digit 0 or 1</p>		

The following table describes possible treatments.

**Examples of possible treatments (Sheet 1 of 2)**

Type of number	Original CDN	Treatment
Local or National	N X...X, LENGTH (X...X) <2	PARTIAL_DIAL
	1 X...X, length (X...X) <3	PARTIAL_DIAL
	1 AXX X...X	VACANT_CODE
Local	NXX X...X, length (X...X) <4	PARTIAL_DIAL
	1 NXX X...X, length (X...X) <4	PARTIAL_DIAL
National	NXX X...X, length (X...X) <7	PARTIAL_DIAL

## PRI Call Routing (continued)

### Examples of possible treatments (Sheet 2 of 2)

Type of number	Original CDN	Treatment
International	1 NXX X...X, length (X...X) <7	PARTIAL_DIAL
	NXX AXX XXXX Z...Z	VACANT_CODE
	1 NXX AXX XXXX Z...Z	VACANT_CODE
	X...X, length (X...X) <7	PARTIAL_DIAL
	AX...X	VACANT_CODE
Legend:		
X = any digit		
Y = any digit		
Z = any digit		
N = digits 2–9		
A = digit 0 or 1		

### Translations table flow

The PRI Call Routing translation process is shown in the flow chart that follows. Call processing in the DMS-100 switch begins with the trunking tables which define the attributes of the PRI trunk group.

For an incoming call, table CLLI identifies the trunk group, and table TRKMEM determines the physical location of the circuit carrying the call. the trunk identifier (CLLI) is used to access table TRKGR, which defines the signaling protocol used by the selected trunk, and table TRKGRP which provides the LTID of the trunk group. The LTID is used to access table LTCALLS.

Table LTCALLS provides the customer group subfield, CUSTGRP, and the network class of service field, NCOS. Subfields CUSTGRP and NCOS are used to access table NCOS for a preliminary translator name, PRELIMXLA, which is the key for table IBNXLA. If there is no translator in table NCOS, the customer group from table LTCALLS is used to access table CUSTHEAD, which contains a customer group translator CUSTXLA. CUSTXLA is used as the key to table IBNXLA, which is the first standard translations table to be accessed.

Translations are involved in DID only to the extent that what is left of the dialed number is sent to the PBX. A number may or may not be delivered.

An incoming call on a PRI trunk contains the NPI and NSF from the SETUP message. the NPI and the NSF jointly determine the call type and translations

---

## PRI Call Routing (continued)

---

for the PRI call. Using this call type, the data in table LTCALLS determines how the call is routed.

The following steps explain how tables are accessed to translate an incoming PRI call.

1. The DMS switch receives the SETUP message. The NDF and NPI are mapped to a call type using the following rule:
  - a. If no NSF exists, the call type is the value of the NPI.
  - b. If an NSF exists, the call type is the value of the NSF.
2. Tables TRKMEM, TRKSGRP, and TRKGRP are accessed to determine the characteristics of the originating trunk group. Table TRKGRP contains the LTID assigned to the trunk.
3. Table LTDEF is accessed using the LTID from table TRKGRP. Table LTDEF determines the access privileges assigned to the LTID.
4. Table LTCALLS is accessed using the LTID from table TRKGRP and the call type. In table LTCALLS, field XLARTE determines the next step of translations. From this point on, digit translation takes place using the called number digits. the called number digits are stored in the number digits portion of the CDN information element. The number digits portion can include prefix digits for a preferred inter-LATA carrier.

If no tuple exists in table LTCALLS for the specific LTID and call type, the call is blocked.

The following figure shows the tables that are accessed in the DMS-100 switch for an incoming call over a PRI trunk.

## PRI Call Routing (continued)

Table flow for incoming PRI call routing.

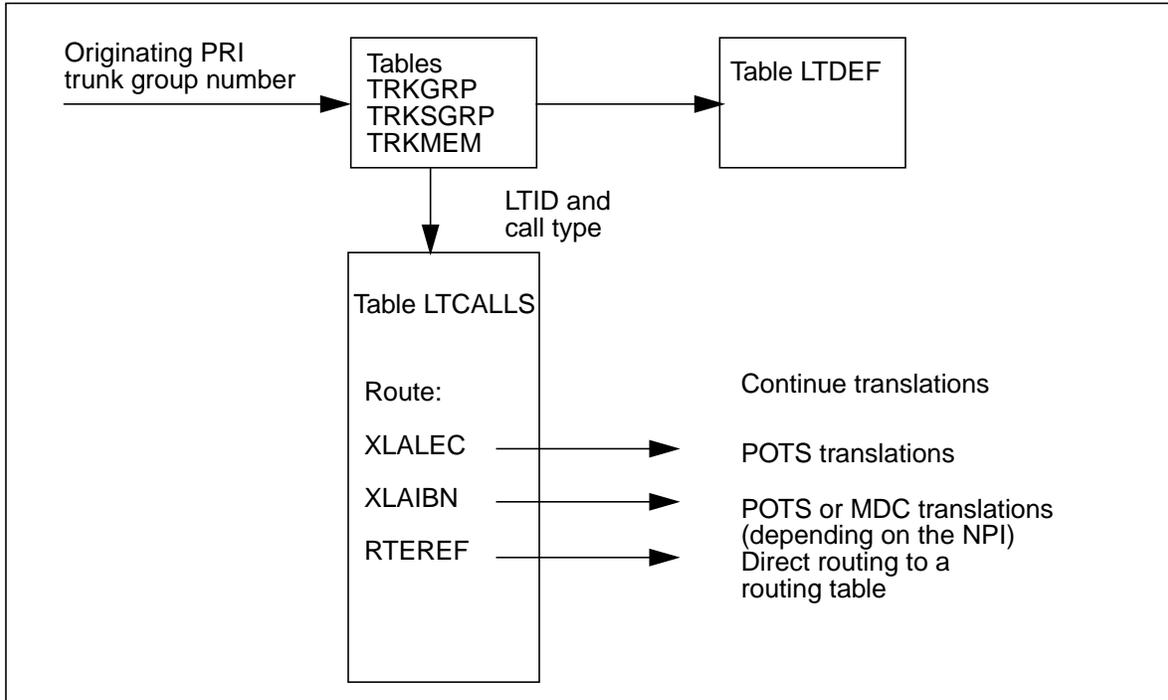

The following is a list of tables that are accessed to translate an outgoing PRI call:

- OFRT
- IBNRTE
- HNPACONT subtable RTEREF
- FNPACONT subtable RTEREF
- FNPACONT.FNPASTS subtable RTEREF

A special route selector called ISA is used in these tables when using ISA. When the ISA route selector is datafilled, the trunk common language location identifier (CLLI) and call type is datafilled.

The following figure shows the tables that are accessed in the DMS-100 switch for an incoming call over a PRI trunk using table ISXLA.



## PRI Call Routing (continued)

Table flow and translations for an incoming PRI call using table ISXLA

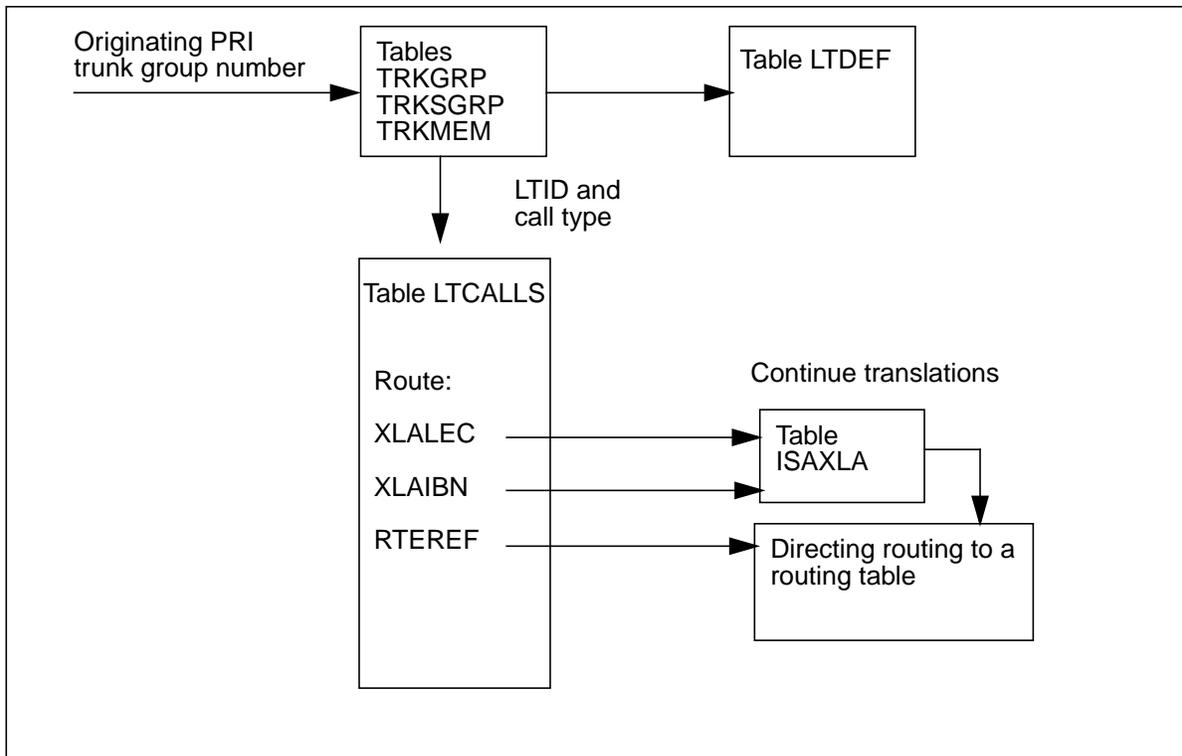

The ISA selector causes an NPI and NSF to be generated for the outgoing call. The NPI and NSF re passed to the terminating node in the SETUP message. It is not mandatory to use the ISA route selector to route to a PRI trunk if the call type is public or private. Rote selectors such as S or N can be used to route private or public calls to a PRI trunk. The ISA route selector generates both an NPI and HSF for the call. If other route selectors are used, only an NPI is generated and passed to the terminating NODE.

Starting with the routing table, the call proceeds with translations in the following way:

1. In the routing table, the ISA route selector routes calls to a specific PRI trunk group by specifying the CLLI of the trunk group. The CLLI value is used to access table TRKGRP.
2. In table TRKGRP, the LTID of the trunk is obtained. Using the LTID from table TRKGRP and the call type from the routing table, table LTCALLS is accessed.
3. Table LTCALLS determines whether the call type is allowed on the trunk. If a tuple is found in table LTCALLS that matches the LTID and call type,

**PRI Call Routing** (continued)

the call is allowed and is routed over the trunk to the terminating node. the NPI and NSF are forwarded to the node in the SETUP message.

If no tuple is found in table LTCALLS that matches the LTID and call type, the call is blocked and the caller receives treatment.

When the ISA route selector is datafilled in a routing table, a digit manipulation index can be specified, if needed. The digit manipulation index points to table DIGMAN and allows the called number digits to be modified before outpulsing.

The following figure shows the table flow for a call terminating to a PRI trunk group.

**Table flow and translations for an outgoing PRI call**

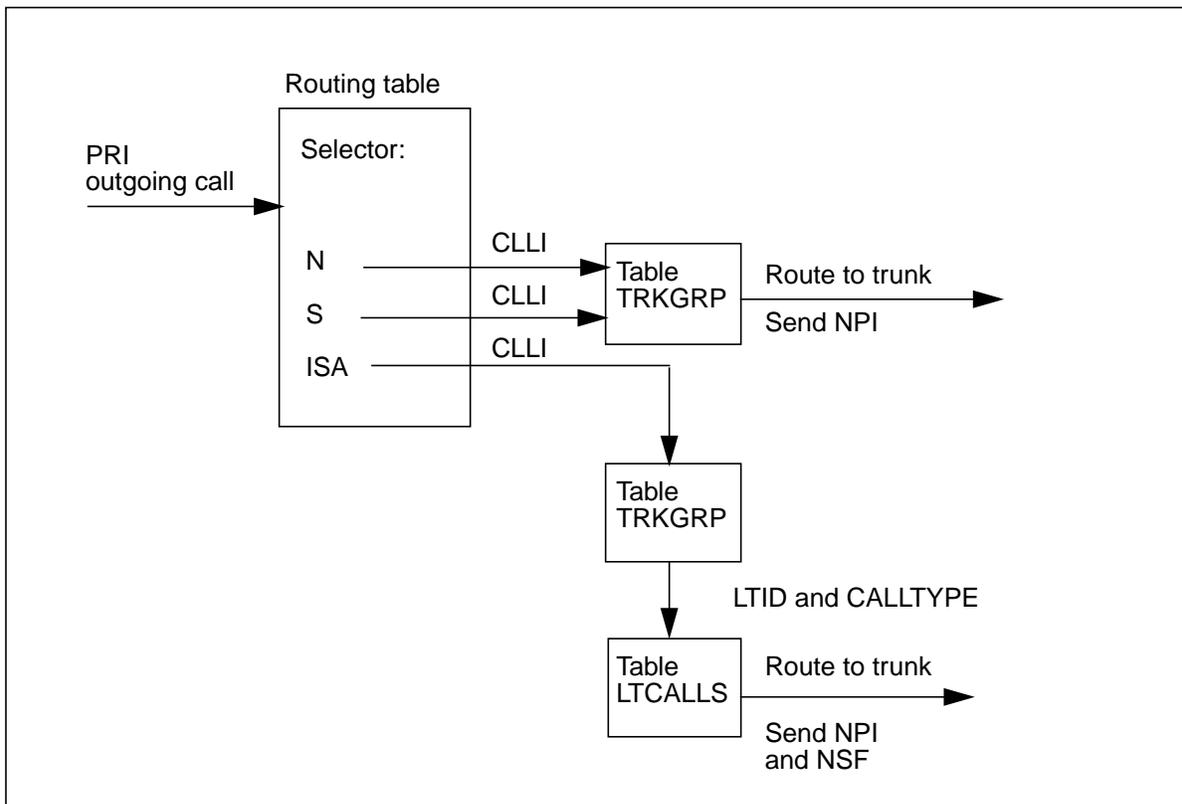

The following figure shows the table flow for PRI Call Routing.

**PRI Call Routing** (continued)

**Table flow for PRI Call Routing**

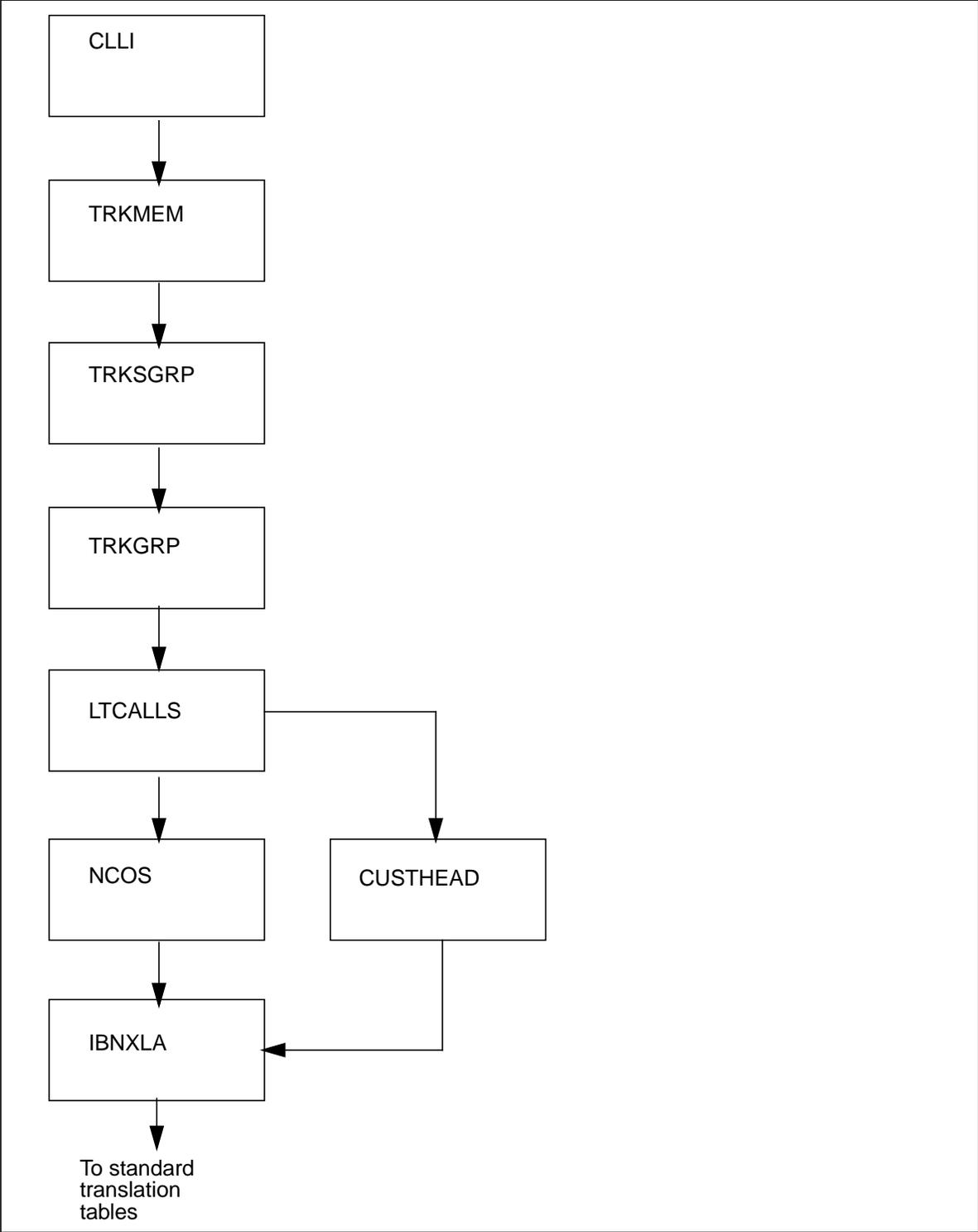

## PRI Call Routing (continued)

---

The following table lists the datafill content used in the PRI Call Routing flowchart.

**Table datafill examples for PRI Call Routing**

Item/table	Example data
Called number	7655432
TRKGRP	PRATRK IBN2 0 NPDGP NCRT COMTST 0 ASEQ 0 N ANSDISC 0 Y N N N N 0 0 N 0 0 0 0 N N N N N N N NATL LTID ISDN 953 \$
LTCALLS	ISDN 953 PVT XLAIBN COMTST 0 0 \$
CUSTHEAD	COMTST PKDK CXDK CUSTFEAT 0 ABC
IBNXLA	CXDK 613 ROUTE N N N 3 N 3 15 NDGT NT OFRT 300
OFRT	300 S PRATRK2

### Limitations and restrictions

PRI Call Routing has no limitations or restrictions.

### Interactions

SID routing overrides Bearer Capability Routing.

### Activation/deactivation by the end user

PRI Call Routing requires no activation or deactivation by the end user.

### Billing

PRI Call Routing does not affect billing.

### Station Message Detail Recording

PRI Call Routing does not affect Station Message Detail Recording.

### Datafilling office parameters

PRI Call Routing does not affect office parameters.

---

## PRI Call Routing (continued)

---

### Datafill sequence

The following table lists the tables that require datafill to implement PRI Call Routing. The tables are listed in the order in which they are to be datafilled.

#### Datafill tables required for PRI Call Routing

Table	Purpose of table
LTCALLS	Provides the initial translations for calls routed over the trunk group.
LTDATA	Provides LTID data and enables the capability.
ISAXLA	Defines the services associated with ISA calls in which the SID is used to determine translations and routing for calls datafilled in table LTCALLS.

### Datafilling table LTCALLS

The following table shows the datafill specific to PRI Call Routing for table LTCALLS. Only those fields that apply directly to PRI Call Routing are shown.

Table LTCALLS provides initial translations for the calls that can be routed over the trunk group. The table is datafilled with the trunk group's LTID, the call type, and the initial translations route for calls.

#### Datafilling table LTCALLS (Sheet 1 of 4)

Field	Subfield	Entry	Explanation and action
LTID		see subfields	Logical terminal identifier. Datafill subfields LTGRP, LTNUM, and CALLTYP as one concatenated entry. Separate the three entries with blanks. You are not prompted for the subfields individually.
	LTGNUM	see subfields	Logical terminal group number. This is made up of subfields LTGRP and LTNUM.
	LTGRP	alphanumeric (1–8 characters)	Logical terminal group. Enter the trunk group name from table LTDEF.
	LTNUM	numeric (1–1022)	Logical terminal number. Enter the trunk group number from table LTDEF.

## PRI Call Routing (continued)

### Datafilling table LTCALLS (Sheet 2 of 4)

Field	Subfield	Entry	Explanation and action
	CALLTYP	PUB, PVT, INWATS, WATS, TIE, FX	Call type. For integrated services access (ISA). Enter pub for public. Enter PVT for private. Enter INWATS for inward wide area telephone service. Enter WATS for outward wide area telephone service. Enter TIE for tie line. Enter FX for foreign exchange.
XLARTSEL		see subfields	Translation route selector.
	XLARTE	XLAIBN, XLALEC	Translation route. Enter XLAIBN for integrated business network for PBX or MDC type offices. Enter XLALEC for local exchange carrier for POTS, PBX, or MDC type offices.  <b>Note:</b> When no tuple exists for a specified LTID and CALLTYPE, the call is blocked.
	LINEATTR	numeric (0–2047)	Line attribute. Enter numeric value for the index into table LINEATTR.  <b>Note:</b> The XLALEC selector cannot be used when field CALLTYPE is PVT, INWATS, or TIE.
	CUSTGRP	alphanumeric (1–16 characters)	Customer group name. Enter the customer group name that is assigned to the line attribute index in table LINEATTR.  <b>Note:</b> Only use this subfield when field XLARTE is XLAIBN. The value must also appear in field CUSTNAME in table CUSTENG.
	SUBGRP	numeric (0–7)	Subgroup. Enter a numeric value to specify the subgroup within the customer group associated with the line attribute index in table LINEATTR.  <b>Note:</b> Only use this subfield when field XLARTE is XLAIBN. The value must also appear in subfield SUBGRPNO in table SUBGRP.

**PRI Call Routing** (continued)

Datafilling table LTCALLS (Sheet 3 of 4)

Field	Subfield	Entry	Explanation and action
OPTIONS	NCOS	numeric (0–511)	Network class of service. Enter a numeric value to specify the key to table NCOS. Only use this subfield when field XLARTE is XLAIBN.
	TABNAME	OFRT, IBNRTE	Table name. Enter OFRT for the OFRT routing table. Enter IBNRTE for the IBNRTE routing table.  <b>Note:</b> Only use this subfield when field XLARTE is RTEREF.
	INDEX	numeric (0–1023)	Index. Enter a numeric value to specify the extended route reference index.  <b>Note:</b> Only use this subfield when field XLARTE is RTEREF.
		see subfield	Options. This field consists of subfield LTCOPT and refinements.
	LTCOPT	SIDXLA	Line trunk controller routing option. enter SIDXLA to route integrated service access (ISA) calls on the service identifier (SID) value. Enter a \$ to end the tuple.  <b>Note:</b> Do not use SID routing when field CALLTYP is PUB. SID routing cannot be used for INWATS call routing in the DMS-100 switch, when the terminating node is a PBX.
	RTRNAME	alphanumeric (up to 8 characters)	Router name, Enter the index into table ISAXLA.
	TREAT_NO_SID	Y, N	Treatment with no SID. The treatment of calls with SID routing that do not have a SID. Enter Y to send the call to treatment. Enter N to send the call to route using the NPI, NSF, and called digits.

## PRI Call Routing (continued)

### Datafilling table LTCALLS (Sheet 4 of 4)

Field	Subfield	Entry	Explanation and action
	NO_CALL_SCREEN	Y, N	No call screening. Turn off screening on the line attributes datafilled in this table. Enter Y to not screen digits. Enter N to use the line attributes to attempt call screening.
	ROUTE_ON_XLARTE	Y, N	<p>Routing on translation route selector. This field determines the public (XLALEC) or private (XLAIBN) translations that are based on field XLARTE, rather than NPI in the SETUP message. Enter Y to set the XLARTE value to override the NPI. Enter N to set the NPI to determine the translation type.</p> <p><b>Note:</b> Calls are affected when either a valid SID entry exists in table ISAXLA with no routing table is datafilled in field RTEID, or no SID is sent in the SETUP message and subfield TREAT_NO_SID is N.</p>

### Datafill example for table LTCALLS

The following example shows sample datafill for table LTCALLS.

### MAP display example for table LTCALLS

LTID	XLARTSEL	OPTIONS
ISDN 1008 PVT XLAIBN 0 CUST1 0 3		(SIDXLA RTE1 N N N) \$

### Datafilling table LTDATA

The following table shows the datafill specific to PRI Call Routing for table LTDATA. Only those fields that apply directly to PRI Call routing are shown. For description of the other fields, refer to the data schema section of this document.



---

**PRI Call Routing** (continued)
 

---

The table is datafilled with the trunk group's LTID, the data type, and logical terminal values.

**Datafilling table LTDATA (Sheet 1 of 2)**

Field	Subfield	Entry	Explanation and action
LTDKEY		see subfields	Logical terminal data key. Datafill subfields LTGRP, LTNUM, and DATATYPE as one concatenated entry. Separate the three values with three blanks. You are not prompted for the subfields individually.
	LTINDEX	see subfields	Logical terminal index. This field is made up of subfields LTGRP and LTNUM.
	LTGRP	alphanumeric (1–8 characters)	Logical terminal group. Enter the trunk group name.
	LTNUM	numeric (1–1022)	Logical terminal number. Enter the logical terminal number within the group.
	DATATYPE	SERV, DN	Logical terminal data type. Enter SERV for service. Enter DN for directory number.
LTDRSLT		see subfields	Logical terminal result.
	DATATYPE	SERV, DN	Data type. Enter SERV for service. Enter DN for directory number. Enter same as LTDKEY datatype subfield of field LTDKEY.
	DFLT CGN	see subfields	Default calling number. Datafill subfields SNPA, NXX, and STATION as one concatenated entry. Separate the three values with blanks. You are not prompted for the subfields individually.  <b>Note:</b> Only use this subfield when subfield DATATYPE is DN.
	SNPA	3 digits	Serving numbering plan area. Enter a 3-digit NPA for the DN.  <b>Note:</b> Only use this subfield when subfield DATATYPE is DN.

**PRI Call Routing** (continued)

**Datafilling table LTDATA (Sheet 2 of 2)**

Field	Subfield	Entry	Explanation and action
LTDRSLT	NXX	3 digits	Central office code. Enter a 3-digit central office code for the DN.  <b>Note:</b> Only use this subfield when subfield DATATYPE is DN.
	STATION	4 digits	Station. Enter a 4-digit station number for the DN.  <b>Note:</b> Only use this subfield when subfield DATATYPE is DN.
	CGNREQD	N	Calling party number required. Enter N.  <b>Note:</b> Only use this subfield when subfield DATATYPE is SERV. This field is presented and must be datafilled, but is not used for PRI.
	CDNDELV	ALWAYS, NEVER	Called party number delivery. Enter ALWAYS to send the called party number to the far end exchange. Enter NEVER to not send the called party number to the far-end exchange.  <b>Note:</b> Only use this subfield when subfield DATATYPE is SERV.

**Datafill example for table LTDATA**

The following example shows sample datafill for table LTDATA.

**MAP display example for table LTDATA**

LTDKEY	LTDRSLT
ISDN 505 SERV	
SERV Y N SCREENED ALWAYS \$	

---

**PRI Call Routing** (continued)

---

**Datafilling table ISAXLA**

The following table shows the datafill specific to PRI Call Routing for table ISXLA. Only those fields that apply directly to PRI Call Routing are shown.

**Datafilling table ISAXLA (Sheet 1 of 2)**

Field	Subfield	Entry	Explanation and action
IRTRNAME		alphanumeric (1—8 characters)	ISA router name. Enter the router name. This field, along with a SID, forms a key into the table.  <b>Note:</b> The router name must be previously datafilled in field RTRNAME in table LTCALLS. A maximum of 128 router names can be datafilled. For each router name, a maximum of 128 different SIDFROM and SIDTO combinations can be datafilled. For the same router name the SIDFROM and SIDTO values cannot overlap each other.
SIDROM		numeric (0–1023)	Service identifier range. Enter the lower boundary of the range of SID values that use the rest of the tuple datafill to continue translations and routing. Calls not within the range are sent to treatment.  <b>Note:</b> This field SIDFROM value must be less than or equal to the field SIDTO value.
SIDTO		numeric (0–1023)	Service identifier upper range. Enter the upper boundary of the range of SID values that use the rest of the tuple datafill to continue translations and routing. Calls not within the range are sent to treatment.  <b>Note:</b> The SIDTO value must be greater or equal to the SIDFROM value.
RTEID		see subfields	Route identifier.

## PRI Call Routing (continued)

### Datafilling table ISAXLA (Sheet 2 of 2)

Field	Subfield	Entry	Explanation and action
	TABNAME	IBNRT2, IBNRT3, IBNRT4, IBNRTE, OFR2, OFR3, OFR4, OFRT, ITOPS	Table name. Enter the name of the routing table used to continue translations.  <b>Note:</b> This field is optional and can be a nil value by datafilling a \$. The calls translate using the NPI, NSF, and called digits. The table name must be previously datafilled in table RTEREF.
	INDEX	numeric (0–1023) or alphanumeric characters.	Index. Enter the index number into the routing table. The index number is used when adding values into the routing table.  <b>Note:</b> Enter 13 for auto-zoning of WARS calls. No routing table name is used with the index 13. The zone D is sent.

### Datafilling example for table ISAXLA

The following example shows sample datafill for table ISAXLA.

IRTRNAME	SIDFROM	SIDTO	RTEID
130WATS	0	1023	(IBNRTE 3) \$

### Error message for table ISAXLA

The following error message applies to table ISAXLA.

#### Error message for table ISAXLA

Error message	Explanation and action
SID VALUE MUST BE GREATER THAN OR EQUAL TO THE SIDFROM VALUE	The field SIDFROM value is greater than the field SIDTO value. Reduce the field SIDFROM value or increase the field SIDTO value.

---

## PRI Call Routing (continued)

---

### Translation verification tools

The TRAVER trace lists the tables accessed to route a specific type of call. The TRAVER command can be used at the MAP (maintenance and administration position) to simulate a call that originates on a PRI trunk by specifying the NPI and NSF in the command line.

**Note:** Dialable Wideband Service (DWS) also affects translations. Refer to Dialable Wideband Service Services Guide.

Enter the TRAVER command for calls that originate on a PRI trunk by typing the following and pressing the Enter key.

```
> TRAVER option clid npd digits nst bc trace
```

#### Entries and explanations

Entry	Explanation
option	Entry option is the command option; use L for line, TR for trunk, or V for virtual facilities group.
clid	Entry clid is the calling line identifier name of the PRI trunk (trunk name).
npd	Entry npd is the numbering plan indicator (optional); use PUB (the default), PVT, E.164, or N which replaces the called digits for a call simulation.
digits	Entry digits is the called party number. Enter CDN.
nsf	Entry nsf is network specific facility (optional); use PRVT (for private), IWT (for INWATS), FX and facility number (0–1023) (for foreign exchange), or TIE and facility number (0–1023) (for tie line). The default is nil.
bc	Entry bc is the bearer capability (optional) from table BCDEF; the default is SPEECH. For data, use 64KDATA.
trace	Entry trace is the type of trace required; use T to trace the table entries referenced by the call, NT for no table entry trace with the call termination displayed, or B for both the table entry trace and the call termination display.

The following examples show the TRAVER for a variety of different incoming and outgoing PRI call routing scenarios.

## PRI Call Routing (continued)

---

### PRI IBNT2 trunk to line—PUB type call

The following list shows the output from TRAVER when it is used to verify the PRI Call Routing CAPABILITY. This TRAVER example routes to the universal PX translators and some PX tables.

1. In lines 1 and 2 of the example, table TRKGRP is accessed with the trunk group CLLI, SLINTPRI, and provides the trunk group LTID, ISDN 570.
2. In lines 3 and 4, the LTID is used to access table LTCALLS, which provides the customer group name, CSTGRP, and the NCOS, 0.
3. In lines 5 to 12, tables NCOS and CUSTHEAD are accessed with the customer group name, CSTGRP, to check for a preliminary translator name. As neither table has one, the customer translator name from table CUSTHEAD, CSTXLA, is used to index table IBNXLA in line 13. Table CUSTHEAD also provides the key (NTS) to table DIGCOL, which specifies that since the first digits received is a 9, the rest of the digits are to be reported one at a time.
4. In table IBNXLA (lines 13 and 14), keyed with translator CSTXLA and the dialed digits, the selector DOD (direct outward dialing) provides line attribute 96, which is the index into table LINEATTR.
5. In table LINEATTR (lines 17 to 19), the translations systems indicator, PX, and the translator name, CSTRAN, are used to access the first of the universal translator tables, PXHEAD.
6. In lines 20 to 22, table PXHEAD sets up defaults and indexes table PXCOD with the translator name, CSTRAN, and the first two of the remaining digits, 73.
7. In lines 23 and 24, table PXCOD defines the route for the call with destination route list number 100, the index into table PXRTE.
8. In lines 25 to 31, table PXRTE is indexed with the translator name, CSTRAN, and the route index, 100, and points to table OFRT, index 459. The entry in table OFRT contains the CLLI of the trunk route for the call, IBNISUP.

The following shows the TRAVER example output for PRI Call Routing.

---

**PRI Call Routing** (continued)

---

**TRAVER output example for PRI Call Routing**

```

Line   Output

traver tr sl1intpri n cdn pub 9735300 b

1  TABLE TRKGRP
2  SL1INTPRI IBNT2 0 NPDGP NCRT CSTGRP 0 ASEQ 0 N ANSDISC 0 Y N N N N
   N N 0 0 N 0 0 0 0 N N N N N N N N N NATL (LTID ISDN 570) $ $
3  TABLE LTCALLS
4  ISDN 570 PVB XLAIBN 201 CSTGRP 0 0 $
5  TABLE NCOS
6  CSTGRP 0 ABCOS 0 0 NTSCOS $
7  TABLE CUSTHEAD: CUSTGRP, PRELIMXLA, FEATXLA, VACTRMT, AND
   DIGCOL
8  CSTGRP NXLA CSTXLA CSTXLA 1 NTS
9  TABLE DIGCOL
10 NTS 9 RPT
11 NCOS PRELIM XLA name is NIL. Go to next XLA name.
12 CUST PRELIM XLA name is NIL. Go to next XLA name.
13 TABLE IBNXLA: XLANAME CSTXLA
14 CSTXLA 97 NET N N N 1 N NDGT N N DOD N 96 NONE $
15 TABLE DIGCOL
16 NDGT specified: digits collected individually
17 TABLE LINEATTR
18 96 IBN NONE NT NSCR 0 003 NPRT NLCA NONE 0 NIL NILSFC NILLATA 0 PX
   CSTRAN NIL 00 N $
19 LCABILL OFF - BILLING DONE ON BASIS OF CALLTYPE
20 TABLE PXHEAD
21 CSTRAN SDFLT DFOP (MM 7 9) (CLASS LCL) $ NOCON STD
22 THE DIGITS USED TO INDEX THE NEXT TABLE ARE: 735300
23 TABLE PXCOD
24 CSTRAN 73 73 RTE (PF2) (MM 2 18) (DEST 100) $
25 TABLE: PXRTE
26 KEY: CSTRAN 100
27 . T OFRT 459
28 . . TABLE OFRT
29 . . 459 ST 100
30 . . EXIT TABLE OFRT
31 EXIT TABLE PXRTE
32
33 *** TRAVER: SUCCESSFUL CALL TRACE ***
34
35
36 DIGIT TRANSLATION ROUTES
37
38 1 IBNISUP                5300                ST
39
40 TREATMENT ROUTES. TREATMENT IS: GNCT
41 1 T60
42
43 *** TRAVER: SUCCESSFUL CALL TRACE ***

```

## **PRI Call Routing** (continued)

---

### **PRI IBNT2 trunk to line—PVT call type**

The following shows the output from TRAVER when it is used to verify the PRI Call Routing capability.

1. In lines 1 and 2 of the example, table TRKGRP is accessed with the trunk group CLLI, SL1 NTPRI, and provides the trunk group LTID, ISDN 570.
2. In lines 3 and 4, the LTID is used to access table LTALLS, which provides the customer group name, TSTCST, and the NCOS, 0.
3. The customer group name is used to search for a translator name for the customer group. First, in lines 5 and 6, table NCOS is accessed with the customer group name and the NCOS, but it does not contain a translator. Table CUSTHEAD in lines 7 and 8 does provide a customer group translator, CSTXLA, which is used to access table IBNXLA.
4. In lines 9 and 10, table IBNXLA provides a route for the call, specifying routing table OFRT, index 459. (There is no digit collection information in table DIGCOL for this customer group.)
5. In lines 13 and 14, table OFRT is accessed with the routing index from table IBNXLA, 459, and provides the trunk CLLI of the trunk route for the call, SL1PRI2.

The following shows the TRAVER example output for PRI Call Routing.



**PRI Call Routing** (continued)**TRAVER OUTPUT example for PRI Call Routing**

```

Line   Output
      traver tr sl1ntpri n cdn pvt 9595300 bc 64kdata b
1  TABLE TRKGRP
2  SL1NTPRI IBNT2 0 NPDGP NCRT TSTCST 0 ASEQ 0 N ANSDISC 0 Y N 3 N N N N
   N 0 0 N 0 0 0 0 N N N N N N N N N NATL (LTID ISDN 570) $
3  TABLE LTCALLS
4  ISDN 570 PVT XLAIBN 201 TSTCST 0 0 $
5  TABLE NCOS
6  TSTCST 0 ABCOS 0 0 NTSCOS $
7  TABLE CUSTHEAD: CUSTGRP, PRELIMXLA, CUSTXLA, FEATXLA, VACTRMT, AND
   DIGCOL
8  TSTCST NXLA CSTXLA 1 NTS
9  TABLE IBXLA: XLANAME CSTXLA
10 CSTXLA 99 ROUTE N N N 3 N 3 15 NDGT N T OFRT 459 $
11 TABLE DIGCOL
12 NDGT specified: digits collecte individually
13 TABLE OFRT
14 459 S D SL1PRI2
15 EXIT TABLE OFRT
16
17 *** TRAVER: SUCCESSFUL CALL TRACE ***

```

**PRI trunk to line—PUB call type**

The following TRAVER shows a call from a PRI trunk to a line.

This call originates on a PRI trunk and terminates to a line in the DMS-100 switch. Since no NPI is specified in the TRAVER command, the NPI is public. There is no NSF for the call. Using the rule for determining call type, the call type is public. The flow through the tables is as follows:

1. Table TRKGRP is accessed to determine the characteristics of the originating trunk group SL1NTPRI. Table TRKGRP also identifies the LTID assigned to the trunk group. the LTID is ISDN 1008.
2. Table LTCALLS is accessed using the LTID from table TRKGRP (ISDN 1008) and the call type (PUB).

The XLAIBN selector in the tuple specifies both a line attribute index (0), and some MDC customer group information (ISDNPRS 00). Because the call has an NPI of public, the line attribute index is used and the customer

## **PRI Call Routing** (continued)

---

group information is ignored. the call enters POTS translations using the line attribute index as a pointer into table LINEATTR.

3. From table LINEATTR, the call continues using standard POTS translations. the call terminates to the line with the directory number 919-473-5856.

The following shows the TRAVER example output for PRI Call Routing.

---

**PRI Call Routing** (continued)
 

---

**TRAVER output example for PRI Call Routing**

Line	Output
	<b>traver tr sl1ntpri 4735856 b</b>
1	TABLE TRKGRP
2	SL1NTPRI PRA 0 NPDGP NCRT ASEQ \$ (ISDN 1008) \$
3	TABLE LTCALLS
4	ISDN 1008 PUB XLAIBN 0 ISDNPRI 0 0
5	TABLE LINEATTR
6	0 1FR NONE NT NSCR 0 919 TOPS NIL NILSFC NILLATA 0 NIL NIL 00 N \$
7	TABLE STDPRTCT
8	POT1 (1) (0)
9	. SUBTABLE STDPRT
10	. 47358 47358 N NP 0 NA
11	. SUBTABLE AMAPRT
12	. KEY NOT FOUND
13	. DEFAULT VALUE IS: NONE N
14	TABLE HNPACONT
15	919 300 2 (22) (1) (0)
16	. SUBTABLE HNPACODE
17	. 473 473 DN 919 473
18	TABLE TOFCNAME
19	919 473 5 Y C
20	TABLE DNINV
21	919 473 5856 L HOST 00 0 08 01
22	TABLE DNATTRS
23	919 473 5856
24	(ISDNPRI (NAME DON) \$)
25	(FASIBNC7 (NAME DONC7) \$) \$
26	TAB;E DNGRPS
27	TUPLE NOT FOUND
28	TABLE LCASCRN
29	919 POTS (6) MAND N
30	. SUBTABLE LCASCR
31	. 473 473
32	TABLE PFXTREAT
33	MAND NP Y UNDT
34	*** TRAVER;1: SUCCESSFUL CALL TRACE ***
35	
36	DIGIT TRANSLATION ROUTES
37	1 LINE 9194735856
38	
39	TREATMENT RUTES. TREATMENT IS: GNCT
40	1 120TONE
41	*** TRAVER: SUCCESSFUL CALL TRACE ***

## **PRI Call Routing** (continued)

---

### **PRI trunk to line—PUB call type with equal access**

The following TRAVER shows an equal access (EA) call from a PRI trunk to a line.

This call originates on a PRA trunk and terminates to a line in the DMS-100 switch. Since no NPI is specified in the TRAVER command, the NPI defaults to public. There is no NSF for the call. Using the rule for determining call type, the call type is public. The flow through the tables in the TRAVER is as follows:

1. The first TRAVER is accessed shows the leg of the call from the trunk group to the virtual facility group (VFG).
  - a. Table TRKGRP is accessed to determine the characteristics of the originating trunk group PRILVHL. Table TRKGRP also identifies the LTID assigned to the trunk group. The LTID is ISDN 2.
  - b. Table LTCALLS is accessed using the LTID from table TRKGRP (ISDN 2) and the call type (PUB).

The RTEREF selector in the tuple specifies that the call will be routed to table IBNRTE, route number 173

- c. Table IBNRTE uses the VFG selector to route the call to a VFG named PRIEA.
2. The second TRAVER shows the leg of the call from the VFG to the line. In this TRAVER the trunks appearing on the route list must be ATC or IT trunks. the VFG cannot be routed directly to a PRI trunk, and then to a carrier, when using the Equal Access Selector.

The following shows the TRAVER example output for PRI Call Routing.

---

**PRI Call Routing** (continued)

---

**TRAVER output example for PRI Call Routing**

Line	Output
	<b>traver tr prilvhl 12135541212 b</b>
1	TABLE TRKGRP
2	TABLE LTCALLS
3	PRILVHL PRA 10 NPDGP NCRT ASEQ N (ISDN 2) \$
4	ISDN 2 PUB RTEREF IBNRTE 173 \$
5	TABLE IBNRTE
6	173 VFG N N PRIEA 0
7	EXIT TABLE IBNRTE
8	*** TRAVER: SUCCESSFUL CALL TRACE ***
9	
10	DIGIT TRANSLATION ROUTES
11	1 VFG: PRIEA 12135541212
12	
13	TREATMENT ROUTES. TREATMENT IS: GNCT
14	1 OVFLTONE
15	*** TRAVER: SUCCESSFUL CALL TRACE ***

The following TRAVER is a continuation of the PUB call type with equal access call showing the leg of the call from the VFG to the line.

**PRI Call Routing** (continued)**TRAVER output example for PRI Call Routing (Sheet 1 of 2)**

```

Line   Output
      traver v priea 12135541212 b
1      TBLE VIRTGRPS
2      PRIEA SIZE 100 POTS 70273555000 O N (EA ATTC Y) $
3      TABLE LINEATTRS
4      0 1FR SPCLL NT LATA 0 702 LOC LSVG TOPS N 10 NIL NILSFC LATA1 0
      NIL NIL 00 N
5      TABLE STDPRTCT
6      LOC (1) (0)
7      . SUBTABLE STDPRT
8      . 12 1554 N DD 1 NA
9      . SUBTABLE AMAPRT
10     . KEY NOT FOUND
11     . DEFAULT VALUE IS: NONE N
12     TABLE HNPACONT
13     702 445 0 (49) (1) (0)
14     . SUBTABLE HNPACONT
15     . 213 219 FRD 1
16     . SUBTABLE RTEREF
17     . 1 N D 2WIT200 0 N N
18     . EXIT TABLE HNPACONT
19     EXIT TABLE RTEREF
20     TABLE LCASCRCN
21     702 LSVG (37) MAND N
22     . SUBTABLE LCASCR
23     . TUPLE NOT FOUND. DEFAULT IS NON-LOCAL
24     TABLE PFXTREAT
25     MAND DD N DD UNDT
26     TBLE CLSVSCRC
27     KEY NOT FOUND
28     DEFAULT IS TO LEAVE XLA RESULT UNCHANGED
29     TABLE OCCINFO
30     ATTC 288 EAP Y Y Y Y N N Y Y Y SHORT 90 FGRPD N N Y N N N N Y
31     TABLE EASAC
32     TUPLE NOT FOUND
33     TABLE LATA1
34     LATA1 21 INTER INTER STD
35     TABLE STDPRTCT
36     LOC (1) (0)
37     . SUBTABLE STDPRT
38     . 10288 10288 EA DD 5 P ATTP ATTC Y OFRT 220 6 20 Y
39     .. TABLE OFRT
40     .. 220 CND EA INTNL SK 5
41     .. N D SNBR 0 N N
42     .. N D 2WIT200 15 D081 N
43     .. N D SNBRINETS 0 N N
44     .. CND ALWAYS SK 4
45     .. N D SNBR 15 D138 N
46     .. N D 2WIT200 15 D138 N
47     .. N D SNBRINETS 0 N N
48     .. S D EAPEG
49     EXIT TABLE OFRT

```

---

**PRI Call Routing** (continued)
 

---

**TRAVER output example for PRI Call Routing (Sheet 2 of 2)**

Line	Output
50	. TABLE STDPRTCT
51	. ATTP (1) (0)
52	.. SUBTABLE STDPRT
53	.. 12 15 EA DD 1 T NA Y OFRT 220 1 1 Y
54	... TABLE OFRT
55	... 220 CND EA INTNL SK 5
56	... N D SNBR O N N
57	... N D 2WIT200 15 D081 N
58	... N D SNBRINETS O N N
59	... CDN ALWAYS SK 4
60	... N D SNBR 15 D138 N
61	... N D SNBRINETS 0 N N
62	... S D EAPEG
63	... EXIT TABLE OFRT
64	*** TRAVER: SUCCESSFUL CALL TRACE ***
65	
66	DIGIT TRANSLATION ROUTES
67	1 SNBR 2135541212 ST
68	2 2WIT200 D081 ST
69	3 SNBRINETS 2135541212 ST
70	TREATMENT ROUTES: TREATMENT IS: GNCT
71	I OVFLTONE
72	*** TRAVER: SUCCESSFUL CALL TRACE ***

**INWATS call type**

The following example shows the TRAVER for a typical ISA INWATS call between a DMS-100 switch and a Meridian 1 PBX at the terminating office.

The first TRAVER is the IBN translations for a private line calling the INWATS number 8002664115. The #430 access code is random and is used to index table IBNXLA. It shows an INWATS call to a virtual facilities group (VFG). the flow through the TRAVER is as follows:

1. At line 40, the call routes with call type PUB and follows standard translations. The tables INWORICN, INWORIBN, and INWTERCN manipulate the digits so that 722-4115 is effectively dialed by a POTS line.
2. TRAVER does not show this routing, but the rest of the TRAVER, from line 40 to 55, is what the translation would look like.

The following TRAVER shows a private call incoming to the DMS-100 switch over a PRI trunk and terminating to a line in the DMS-100 switch.

## PRI Call Routing (continued)

### TRAVER output example for PRI Call Routing (Sheet 1 of 2)

Line	Output
	<b>traver I 7227000 'c4308002664'15't b</b>
1	TABLE KSETLINE
2	HOST 00 0 03 24 1 DN Y 7227000 ABCLTD 0 0 613 (CWT) (3WC) (MCH) (RAG) (CWI) (DCBX) (PRK) (EBO) (EBX) (LNR) (CPU) (CFX) (MWT) \$
3	TABLE DNATTRS
4	613 722 700 (PUBLIC (NAME JOHN_DOE) \$) \$ \$
5	TABLE DNGRPS
6	TUPLE NOT FOUND
7	TABLE NCOS
8	ABCLTD 0 0 0 ABC0 (OHQ 0 TONE_OHQ) (CBQ 0 3 N 2) \$
9	TABLE CUSTHEAD: CUSTGRP PRELIMXLA, CUSTXLA, FEATXLA, VACTRMT, AND DIGCOL
10	ABCLTD PXDK CXDK FTCOMM 0 ABC
11	TABLE DIGCOL
12	ABC OCT RPT
13	NCOS OCT XLA NAME IS NIL. GO TO NEXT XLA NAME.
14	TABLE IBNXLA: XLANAME KPRA25
15	KPRA25 430 NET N Y N 3 Y NDGT Y N GEN (LATTR 0) \$
16	TABLE DIGCOL
17	NDGT SPECIFIED: DIGITS COLLECTED INDIVIDUALLY
18	TABLE LINEATTR
19	0 1FR NONE HT FR01 613 P621 L613 N TSPS N 10 NIL NILSFC
20	LCABILL OFF - BILLING DONE ON BASIS OF CALL TYPE
21	TABLE STDPRTCT
22	P621 (1) (0)
23	. SUBTABLE
24	. 80 810 N NP 0 NA
25	. SUBTABLE AMAPRT
26	. KEY NOT FOUND
27	. DEFAULT VALUE IS: NONE OVRNONE N
28	TABLE HNPACONT
29	613 666 1 (57) (1) (84) (0)
30	. SUBTABLE HNPACODE
31	. 800 800 INWO 0
32	TABLE INWORICN
33	266 18 08 0
34	TABLE IWORIBN
35	266 613 1 N
36	TABLE INWTERCN
37	17 411 722 5 6
38	TABLE IWTERTE



---

**PRI Call Routing** (continued)

---

**TRAVER output example for PRI Call Routing (Sheet 2 of 2)**

```
39 5 RT 613 NP NLCL 0 N 613 $
40 TABLE CASRCN
41 613 L613 (12) MNDT N
42 . SUBTABLE LCASCR
43 . TUPLE NOT FOUND. DEFAULT IS TO LEAVE XLA RESULT UNCHANGED
44 TBLE CLSVSCRC
45 KEY NOT FOUND
46 DEFAULT IS TO LEAVE XLA RESULT UNCHANGED
47 LATA IS NIL, THEREFORE NOT AN EQUAL ACCESS CALL
48 *** TRAVER: SUCCESSFUL CALL TRACE ***
49
50 DIGIT TRANSLATION ROUTES
51 1 VFG: INW1          72114115      ST
52 TREATMENT ROUTES. TREATMENT IS: GNCT
53 1 *OFLO
54 2 LKOUT
55 *** TRAVER: SUCCESSFUL CALL TRACE ***
```

This TRAVER is a retranslation of the previous call as if it is originating on a POTS line. It shows the retranslation for an ISA INWATS call.

**PRI Call Routing** (continued)**TRAVER output example for PRI Call Routing**

```

Line  Output
      traver I 6211172 '7224115' b
1     TABLE LINEATTR
2     0 1FR NONE FR01 0 613 P621 L613 N TSPS N 10 NIL NILSEC
3     LCABILL OFF - BILLING DONE ON BASIS OF CALL TYPE.
4     TABLE DNATTRS
5     TUPLE NOT FOUND
6     TABLE DNGRPS
7     TUPLE NOT FOUND
8     TABLE STDPRTCT
9     P621 (1) (0)
10    . SUBTABLE STDPRT
11    . 7 810 N NP 0 NA
12    . SUBTABLE AMAPRT
13    . KEY NOT FOUND
14    . DEFAULT VALUE IS: NONE OVRNONE N
15    TABLE HNPACONT
16    613 666 1 (57) (1) (0)
17    . SUBTABLE HNPACODE
18    . 722 722 DN 613 722
19    TABLE TOFCNAME
20    613 722 4 Y C
21    TABLE DNINV
22    613 722 4115 T IBNRTE 444
23    TABLE DNATTRS
24    TUPLE NOT FOUND
25    TABLE DNGRPS
26    TUPLE NOT FOUND
27    TABLE IBNRTE
28    444 IW 14 722 INW1 444
29    . TABLE DIGMAN
30    . 444 (REM 3) (INC 721)
31    . EXIT TABLE DIGMAN
32    EXIT TABLE IBNRTE
33    TABLE LCASCRCN
34    613 L613 (12) MNDRTE N
35    . SUBTABLE LCASCR
36    . TUPLE NOT FOUND. DEFAULT IS NON-LOCAL
37    TABLE PFXTRTREAT
38    TUPLE NOT FOUND. DEFALRT IS TO LEAVE XLA RESULT UNCHANGED
39    TABLE CLSVSCRC
40    KEY NOT FOUND
41    DEFAULT IS TO LEAVE XLA RESULT UNCHANGED
42    *** TRAVER: SUCCESSFUL CALL TRACE ***
43
44    DIGIT TRANSLATION ROUTES
45    1 VFG: INW1          7214115      ST
46
47    TREATMENT ROUTES. TREATMENT IS: GNCT
48    1 *OFLO
49    2 LKOUT
50    *** TRAVER: SUCCESSFUL CALL TRACE ***

```

---

**PRI Call Routing** (continued)

---

The following TRAVEL is an example of a call going through the VFG INW1 for throttling and billing. The call is then routed over a PRI trunk. It shows the DMS-100 switch termination with call type IWT.

## PRI Call Routing (continued)

### TRAVER output example for PRI Call Routing

```

Line  Output
      traver v inw1 '7214115' b
1     TABLE virtgrps
2     INW1 SIZE 1 POTS 7227010 0 N $
3     TABLE LINEATTR
4     0 1FR NONE NT FR01 0 613 P621 L613 NTSPT N 10 NIL NILSFC
5     LCABILL OF - BILLING DONE ON BASIS OF CALLTYPE
6     TABLE STDPRTCT
7     P621 (1) (0)
8     . SUBTABLE STDPRT
9     . 7 810 N NP 0 NA
10    . KEY NOT FOUND
11    . DEFAULT VALUE IS: NONE OVRNONE N
12
13    TABLE HNPACONT
14    613 322 1 (57) (1) (84) (0)
15    . 721 721 lrte 333
16    . SUBTABLE RTEREF
17    . . 333 ISA N N N K2KDT164CLLP1 INWATS 2 E164 333 $
18    . . TABLE TRKGRP
19    . . KEKDT164CLLP1 PRA 0 PRAC NCRT ASEQ N (ISDN 301) $
20    . . TABLE LTCALLS
21    . . ISDN 301 INWATS XLAIBN 0 ABCLTD 0 25 $
22    . . TABLE DIGMAN
23    . . 333 (CF 2) (REM 5) (INC 27010)
24    . . EXIT TABLE DIGMAN
25    . EXIT TABLE RTEREF
26    EXIT TABLE HNPACONT
27    TABLE LCASCRCN
28    613 L613 (12) MNDR N
29    SUBTABLE LCASCR
30    TUPLE NOT FOUND. DEFAULT IS NON-LOCAL
31    TABLE PFXTREAT
32    TUPLE NOT FOUND. DEFAULT IS TO LEAVE XLA RESULT UNCHANGED $
33    TABLE CLSVSCRC
34    KEY NOT FOUND
35    DEFAULT IS TO LEAVE XLA RESULT UNCHANGED
36    LATA IS NIL, THEREFORE NOT AN EQUAL ACCESS CALL
37    *** TRAVER: SUCCESSFUL CALL TRACE ***
38
39    DIGIT TRANSLATION ROUTES
40    1 K2KDT164CLLP1 N CDN E164 7227010 IWT 2 BC SPEECH
41
42    TREATMENT ROUTES. TREATMENTS IS: GNCT
43    1 *OFLO
44    2 LKOUT
45    *** TRAVER :SUCCESSFUL CALL TRACE ***

```

---

## **PRI Call Routing** (continued)

---

The following TRAVER example shows the standard translations for a Meridian 1 Options 111-211 (SL-100 system) origination with A call type IWT.

**PRI Call Routing** (continued)**TRAVER output example for PRI Call Routing**

```

Line  Output
      traver tr k2dt164cllp2 n cdn e164 7227010 iwt b
1     TABLE TRKGRP
2     K2KDT164CLLP2 PRA 0 PRAC NCRT DSEQ N (ISDN 302) $
3     TABLE LTCALLS
4     ISDN 302 INWATS XLAIBN 0 ABCLTD 0 25 $
5     TABLE LINEATTR
6     00 1FR NONE NT FR01 0 613 P621 L613 N TSPS N 10 NIL NILSFC
7     LCABILL OFF - BILLING DONE ON BASIS OF CALLTYPE
8     TABLE STDPRTCT
9     P621 (1) (0)
10    . SUBTABLE STDPRT
11    . 7 810 N NP 0 NA
12    . SUBTABLE AMAPRT
13    . KEY NOT FOUND
14    . DEFAULT VALUE IS: NONE OVRNONE N
15    TABLE HNPACONT
16    613 666 1 (57) (1) (0)
17    . SUBTABLE HNPACODE
18    . 722 722 DN 613 722
19    TABLE TOFCNAME
20    613 722 7 Y C
21    TABLE DNINV
22    613 722 7010 IMC SCA 5
23    TABLE DNATTRS
24    TUPLE NOT FOUND
25    TABLE DNGRPS
26    TUPLE NOT FOUND
27    TABLE LCASCRCN
28    613 L613 (12) MNDR N
29    . SUBTABLE LCASCRC
30    . TUPLE NOT FOUND. DEFAULT IS NON-LOCAL
31    TABLE PFXTREAT
32    TUPLE NOT FOUND. DEFAULT IS TO LEAVE XLA RESULT UNCHANGED
33    TABLE CLSVCRC
34    KEY NOT FOUND
35    DEFAULT IS TO LEAVE XLA RESULT UNCHANGED
36    *** TRAVER: SUCCESSFUL CALL TRACE ***
37
38    DIGIT TRANSLATION ROUTES
39    1 LINE          6137227010          ST
40    TREATMENT ROUTES. TREATMENT IS: GNCT
41    1 T120
42    *** TRAVER: SUCCESSFUL CALL TRACE ***

```

---

**PRI Call Routing** (continued)

---

**PRI IBNT2 trunk to line—PUB call type**

The following TRAVER shows a call originating from an IBNT2 trunk set up for PRI and terminating to a line. As shown in the TRAVER command, the NPI for the call is public and the NSF is absent (unknown). The call defaults to public. The flow of the tables is as follows:

1. Table TRKGRP determines the characteristics of the originating trunk group and specifies the LTID assigned to the trunk group (ISDN 1016).
2. Table LTCALLS is accessed using the LTID from table TRKGRP (ISDN 1016) and the call type (PUB). the XLALEC translation selector is used to specify a line attribute index (0).

Table LINEATTR is accessed using the line attribute index from table LTCALLS. The call continues with standard POTS translations.

**PRI Call Routing** (continued)**TRAVER output example for PRI Call Routing**

```

Line  Output
      traver tr crminpri64k pub 4735856 b
1    TABLE TRKGRP
2    CRMINIPRA64K IBN2 0 NPDGP NCRT ISDN2 0 MIDL 0 N ANSDISC 0 Y N N N
   N N N N 0 0 N 0 0 0 0 0 N N N N N N N N N (LTID ISDN 1016) $
3    TABLE LTCALLS
4    ISDN 1016 PUB XLALEC 0 $
5    TABLE LINEATR
6    0 1FR NONE NT NSCR 0 919 POT1 POTS TOPS N 0 NIL NILSFC NILLATA 0
   NIL NIL 00 N
7    TABLE STDPRTCT
8    POT1 (1) (0)
9    . SUBTABLE STDPRT
10   . 47358 N NP 0 NA
11   . SUBTABLE AMAPRT
12   . KEY NOT FOUND
13   . DEFAULT VALUE IS: NONE N
14   TABLE HNPACONT
15   919 300 2 (22) (1) (0)
16   . SUBTABLE HNPACODE
17   . 473 473 DN 919 473
18   TABLE TOFCNAME
19   919 473 5 Y C
20   TABLE DNINV
21   919 473 5856 L HOST 00 0 08 01
22   TABLE DNATTRS
23   919473 5856
24   (ISDNPRA (NAME DON) $)
25   (FASTIBNC7 (NAME DONC7) $) $
26   TABLE DNGRPS
27   TUPLE NOT FOUND
28   TABLE LCASCRCN
29   919 POTS (6) MAND N
30   . SUBTABLE LCASCR
31   . 473 473
32   TABLE PFXTRAET
33   MAND NP Y NP UNDT
34   *** TRAVER: SUCCESSFUL CALL TRACE ***
35
36   DIGIT TRANSLATION ROUTES
37   1 LINE          9194735856
38   TREATMENT ROUTES. TREATMENT IS: GNCT
39   1 120TONE
40   *** TRAVER: SUCCESSFUL CALL TRACE ***

```



---

## PRI Call Routing (continued)

---

### PRI IBNT2 trunk to line—PVT call type

The following TRAVER shows a call originating from an IBNT2 trunk group set up for PRI and terminating to a line.

This call is incoming over the PRI trunk group CRMINNPRI64K. In the TRAVER command, both the NPI and the NSF are specified as being private (NPI is PVT, NSF is PRVT). Using the rule for determining call type, the call is private.

The flow through the tables in the TRAVER is as follows:

1. Table TRKGRP is accessed to determine the characteristics of the originating trunk group. Table TRKGRP specifies the LTID assigned to the trunk group (ISDN 1016).
2. Table LTCALLS is accessed using the LTID from table TRKGRP (ISDN 1016) and the call type (private). This tuple is using the XLAIBN selector which specifies a line attribute index (10) and some MDC customer group information is accessed while the line attribute is ignored. The MDC information consists of a customer group name (ISDN2), the subgroup (0), and the NCOS (0).
3. The call continues with the standard MDC translations. the call terminates to the line with the directory number 919-473-5856.

**PRI Call Routing** (continued)**TRAVER output example for PRI Call Routing****Line Output****traver tr crminpri64k pub 4735856 b**

```

1 TABLE TRKGRP
2 CRMINIPRA64K IBN2 0 NPDGP NCRT ISDN2 0 MIDL 0 N ANSDISC 0 Y N N N
  N N N N 0 0 N 0 0 0 0 N N N N N N N N N (LTID ISDN 1016) $
3 TABLE LTCALLS
4 ISDN 1016 PVT XLAIBN 10 ISDN2 0 0 $
5 TABLE NCOS
6 ISDN2 0 0 0 ISDN2 $
7 TABLE CUSTHEAD: CUSTGRP, PRELIMXLA,CUSTXLA,FEATXLA,VACTRMT,AND DIGCOL
8 ISDN2 NXLA CXLAL NXLA 0 ISDGT1
9 TABLE DIGCOL
10 ISDGT1 4 POTS N
11 NCOS PRELIM XLA NAME IS NIL. GO TO NEXT XLA NAME.
12 CUST PRELIM XLA NAME IS NIL. GO TO NEXT XLA NAME.
13 TABLE IBNXLA: XLANAME CXLAL
14 TUPLE NOT FOUND
15 DEFAULT FROM TABLE XLANAME:
16 CXLAL (NET Y Y 0 N ISDG1 N N DOD N 10 NONE) $
17 TABLE DIGCOL
18 ISDGT1 4 POTS N
19 TABLE LINEATTR
20 10 IBN NONE NT NSCR 0 919 POT1 NLCA CTOP N 0 NIL NILSFC
21 NILLATA 0 NIL NIL 00 N
22 TABLE STDPRCT
23 POT1 (1) (0)
24 . SUBTABLE STDPRT
25 . 47358 47358 N NP 0 NA
26 . SUBTABLE AMAPRT
27 . KEY NOT FOUND
28 . DEFAULT VALUE IS: NONE N
29 TABLE HNPACONT
30 919 300 2 (22) (1) (0)
31 . SUGTABLE HNPACODE
32 . 473 473 DN 919 473
33 TABLE TOFCNAME
34 919 473 5 Y C
35 TABLE DNINV
36 919 473 5856 L HOST 00 0 08 01
37 TABLE DNATTRS
38 919 473 5856
39 (ISDNPRA (NAME DON) $) $
40 TABLE DNGRPS
41 TUPLE NOT FOUND
42 *** TRAVER: SUCCESSFUL CALL TRACE ***
43 DIGIT TRANSLATION ROUTES
44 1 LINE 9194735856
45 TREATMENT ROUTES. TREATMENT IS: GNCT
46 1 120TONE
47 *** TRAVER: SUCCESSFUL CALL TRACE ***

```

---

**PRI Call Routing** (continued)

---

**Line to PRI trunk**

The following TRAVER shows a call that originates from a line on the DMS-100 switch and terminates to a PRI trunk.

There is nothing unique to PRI in this TRAVER except for the fact that table STDPRTCT is routing the call to a PRI trunk group, sl1ntpri. In table STDPRTCT, the S route selector in one of the routing tables is not being used to route the call, no NSF is generated for the outgoing call.

## PRI Call Routing (continued)

### TRAVER output example for PRI Call Routing

```

Line  Output
      traver l 4735870 4735107 b
1    TABLE KSETLINE
2    HOST 00 0 19 02 42 DN Y 4735870 ISDN2 0 0 919 (3WC) (RAG) (PRK)
      (EBO) (MSB) (CPU) $
3    TABLE DNATTRS
4    TUPLE NOT FOUND
5    TABLE DNGRPS
6    TUPLE NOT FOUND
7    TABLE NCOS
8    ISDN2 0 0 0 ISDN2 $
9    TABLE CUSTHEAD: CUSTGRP, PRELIMXLA, CUSTXLA, FEATXLA, VACTRMT
      AND DIGCOL
10   ISDN2 NXLA CXLA1 NXLA 0 ISDGT1
11   TABLE DIGCOL
12   ISDGT1 4 POTS N
13   NCOS PRELIM XLA NAME IS NIL. GO TO NEXT XLA NAME.
14   CUST PRELIM XLA NAME IS NIL. GO TO NEXT XLA NAME.
15   TABLE IBNXLA: XLANAME CXLA1
16   TUPLE NOT FOUND
17   DEFAULT FROM TABLE XLANAME:
18   CXLA1 (NET Y Y 0 N ISDGT1 N N DOD N 10 NONE) $
19   TABLE DIGCOL
20   ISDGT1 4 POTS N
21   TABLE LINEATTR
22   10 IBN NONE NT NSCR 0 919 POT1 NLCA CTOP N 0 NIL NILSFC NILLATA 0
23   NIL NIL 00 N
24   TBLE STDPRCT
      POT1 (1) (0)
25   . SUBTABLE STDPRT
26   . 47351 47351 S NP 3 SL1NTPRA1 4 7 NONE
27   . SUBTABLE AMAPRT
28   . KEY NOT FOUND
29   . DEFAULT VALUE IS: NONE N
30
31   *** TRAVER: SUCCESSFUL CALL TRACE ***
32
33   DIGIT TRANSLATION ROUTES
34   1 SL1NTPRI1          5107          ST
35   TREATMENT ROUTES. TREATMENT IS: GNCT
36   1 120TONE
37   *** TRAVER: SUCCESSFUL CALL TRACE ***

```

#### Line to PRI trunk—TIE call type

The following TRAVER shows a call originating from an ISDN Line and terminating to a PRI trunk.

---

**PRI Call Routing** (continued)

---

The flow through the tables is as follows:

1. Table IBNRTE is used to route the call. the USA route selector in table IBNRTE routes the call to the CLLI called SL1NTPRI. The call type is TIE and the numbering plan indicator is private. Because the ISA route selector is used, both an NPI and an NSF is included in the outgoing SETUP message. The NPI is private and the NSF is TIE.
2. Table TRKGRP is accessed using the CLLI from table IBNRTE. Table TRKGRP specifies the characteristics of the terminating trunk group and also contains the LTID assigned to the trunk (ISDN 1008).
3. Table LTCALLS is accessed using the LTID from table TRKGRP (ISDN 1008) and the call type (TIE). Because table LTCALLS contains a tuple for ISDN 1008 TIE, the call is allowed to complete.

The following TRAVER shows the translation table flow for this call example.

## PRI Call Routing (continued)

### TRAVER output example for PRI Call Routing

```

Line   Output
      traver l 4735800 '5107' b
1  TABLE KSETLINE
2  ISDN 20 1 DN Y 4735800 ISDNPRI 0 0 919 (CWT) (3WC) (MCH) (RAG)
   (CWI (DCBI) (MSB) (MWT) $
3  TABLE DNATTRS
4  919 473 580 (ISDNPRI(NAME ROBERT) $)(FASTIBNC7 (NAME 5 ROBERTC7)$)$
5  TABLE DNGRPS
6  TUPLE NOT FOUND
7  TABLE NCOS
8  ISDNPRI 0 0 0 NCPRA (XLAS CXPRA CXLAL NDGT) (CRL 15 BLOCKED)
9  (DFLTNET ISDNPRI) (IDDDARS N) $
10 TABLE CUSTHEAD: CUSTGRP,PRELIMXLA,CUSTXLA,FEATXLA,VACTRMT
   AND DIGCOL
11 ISDNPRI NXLA CXPRA CXN2 0 DCPRA
   TABLE DIGCOL
12 DCPRA 5 COL S 3
13 TABLE IBNXLA: XLANAME CXPRA
14 CXPRA 51 ROUTE N YN0 N 4 4 DCPRA y T IBNRTE 50
15 TABLE DIGCOL
16 DPRA 5 COL S 3
17 TABLE IBNRTE
18     50 ISA N N N SLINTPRI TIE 1 PVT 0
19     . TABLE TRKGRP
20     . SLINTPRI PRA 0 NPDGP NCRT ASEQ $ (ISDN 1008) $
21     .TABLE LTCALLS
22     . ISDN 1008 TIE XLAIBN 0 ISDNPRI 0 0 $
23 EXIT TABLE IBNRTE
24 *** TRAVER: SUCCESSFUL CALL TRACE ***
25
26 DIGIT TRANSLATION ROUTES
27 1 SLINTPRI             PVT 5107 TIE 1 BC SPEECH
28 TREATAMENT ROUTES. TREATMENT IS: GNCT
29 1 120TONE
30 *** TRAVER: SUCCESSFUL CALL TRACE ***

```

### Line to PRI trunk—PVT call type

The following TRAVER shows a call from a line on the DMS-100 switch to a PRI trunk. This call uses the ISA selector in table OFRT to route the call. The flow through TRAVER is as follows.

1. The call begins as a regular MDC call in table KSETLINE and proceeds through the MDC translations tables. Table IBNXLA routes the call to table OFRT route number 407.
2. Table OFRT, route number 407, uses the ISA route selector to route the call. This tuple specifies the PRI trunk CLLI to which the call routes

---

**PRI Call Routing** (continued)

---

- (K2KPRA64CLLP4). It specifies the call type (PVT), the NPI (PVT), and a digit manipulation index (702).
3. Table TRKGRP is accessed using the CLLI name (K2KPRA64CLLP4) from table OFRT. Table TRKGRP specifies the characteristics of the terminating trunk group and specifies the LTID assigned to the trunk (ISDN 601).
  4. Table LTCALLS is accessed using the LTID from table TRKGRP (ISDN 1008) and the call type from table OFRT (PVT). Because a tuple is found in table LTCALLS for ISDN 601 PVT, the call is allowed.
  5. Table DIGMAN is accessed using the digit manipulation index from table OFRT (702). Table DIGMAN modifies the called digits.
  6. As shown in the digit translation routes part of the TRAVER, the call is routed to the PRA trunk K2KPRA64CLLP4. The SETUP message contains an NPI of PVT, called digits 4020, and as NSF of PVT. The default bearer capability (BC) is speech.

The following example TRAVER shows a call from a line to a PRI trunk.

## PRI Call Routing (continued)

### TRAVER output example for PRI Call Routing

```

Line  Output
      traver I 7224009 'c453344020' b
1     TABLE KSETLINE
2     HOST 04 1 13 13 1 DN Y 7224009 ABCLTD 0 0 613 $
3     TABLE DNATTRS
4     TUPLE NOT FOUND
5     TABLE DNGRPS
6     TUPLE NOT FOUND
7     TABLE NCOS
8     ABCLTD 0 0 0 ABC0 (OHQ 0 TONE_OHQ) (CBQ 0 3 N 2) $
9     TABLE CUSTHEAD: CUSTGRP,PRELIMXLA,CUSTXLA.FEATXLA,VACTRMT
      AND DIGCOL
10    ABCLTD PXDK CXDK CUSTFEAT 0 KDK
11    TABLE DIGCOL
12    ABC OCT RPT
13    NCOS OCT XLA name is NIL. Go to nest XLA name.
14    TABLE IBNXLA: XLANAME KPRA25
15    KPRA25 45 ROUTE N N 2 Y 3 15 NDGT N T OFRT 407
16    TABLE DIGCOL
17    NDGT specified: digits collected individually.
18    TABLE OFRT
19    407 ISA N N N K2KPRA64CLLP4 PVT PVT 702
20    . TABLE TRKGRP
21    . K2KPRA64CLLP4 PRA 0 PRAC NCRT ASEQ N (ISDN 601) $
22    . TABLE LTCALLS
23    . ISDN 601 PVT XLAIBN 0 ABCLTD 0 25 $
24    . TABLE DIGMAN
25    . 702 (REM 3)
26    . EXIT TABLE DIGMAN
27    EXIT TABLE OFRT
28    ***TRAVER: SUCCESSFUL CALL TRACE ***
29
30    DIGIT TRANSLATION ROUTES
31    1 SL1NTPRI          E164 4020 PVT BC SPEECH
32    *** TRAVER: SUCCESSFUL CALL TRACE ***

```

### Line to PRI trunk—TIE call type

The following TRAVER shows a call originating from a line on the DMS-100 switch and terminating to a PRI trunk. The call is routed using the ISA elector in table IBNRTE. The flow through the TRAVER is as follows:

1. The call begins from an MDC line in table KSETLINE. The call proceeds with regular MDC translations. Table IBNXLA routes the call to table IBNRTE, route number 402.
2. Table IBNRTE, route number 402, uses the ISA route selector to route the call to the PRI trunk CLLI 'K2KPRA64CLLP2'. The call type is TIE and



---

**PRI Call Routing** (continued)

---

the facility number is 1. The NPI is PVT. The digit manipulation index is 0 (no digit manipulation required).

3. Table TRKGRP is accessed using the CLLI from table IBNRTE (K2KPRA64CLLP2). Table TRKGRP specifies the characteristics of the terminating trunk group and specifies the trunk LTID (ISDN 241).
4. Table LTCALLS is accessed using the LTID from table TRKGRP (ISDN 241) the call type from table IBNRTE (TIE). Since a tuple is found in table LTCALLS, the call is allowed to terminate.
5. As shown in the digit translation route part of the TRAVER, the call is routed to the PRI trunk 'K2KPRA64CLLP2'. Because the ISA route selector was used, both an NPI and NSF are generated for the call. The NPI is PVT and the NSF is TIE. The outpulsed digits are 4008. The bearer capability (BC) defaults to speech.

The following is the example TRAVER showing the call from a line to a PRI trunk.

## PRI Call Routing (continued)

### TRAVER output example for PRI Call Routing

```

Line  Output
      traver I 7224020 'c464009" b
1     TABLE KSETLINE
2     HOST 00 0 00 16 DN Y 7224020 ABCLTD 0 0 613 (RAG) (CPU) (CFX) $
3     TABLE NCOS
4     ABCLTD 0 0 ABC0 (OHQ 0 TONE_OHQ) (CBQ 0 3 N 2) $
5     TBLE CUSTHEAD: CUSTGRP,PRELIMXLA,CUSTXLA,FEATXLA,VACTRMT
      AND DIGCOL
6     ABCLTD PXDK CXDK CUSTFEAT 0 KDK
7     TABLE DIGCOL
8     ABC OCT RPT
9     NCOS OCT XLA name is NIL. Go to next XLA name.
10    TBLE IBNXLA: XLZNAME KPRS25
11    KPRA25 46 ROUTE N N 2 Y 3 15 NDGT N T IBNRE 402
12    TABLE DIGCOL
13    NDGT specified: digits collected individually.
14    TABLE IBNRE
15    402 ISA N N N K2KPRA64CLLP2 PRA 0 PRAC NCRT DSEQ N (ISDN 241) $
16    . TABLE TRKGRP
17    . K2KPRA64CLLP2 PRA 0 PRAC NCRT DSEQ N (ISDN 241) $
18    . TABLE LTCALLS
19    . ISDN 241 TIE XLAIBN 0 ABCLTD 0 25 $
20    EXIT TABLE OFRT
21    *** TRAVER: SUCCESSFUL CALL TRACE ***
22
23    DIGIT TRANSLATION ROUES
24    1 K2KPRA64CLLP2          PVT 4008 TIE  BC SPEECH
25    TREATMENT ROUTES. TREATMENT IS: GNCT
26    1 *OFLO
27    2 LKOUT
28    *** TRAVER: SUCCESSFUL CALL TRACE ***

```

#### Line to PRI trunk—PUB call type

The following TRAVER shows a call originating from a POTS line and terminating to a PRI trunk. This call uses the ISA route selector in table HNPACONT.RTEREF to route the call. The NPI and call type are public. The flow through the TRAVER is as follows:

1. The TRAVER does not show the reference into table LENLIES and table LENFEAT that begins a POTS call. The TRAVER begins in table LINEATTR and proceeds through regular POTS translations. The RTEREF subtable in table HNPACONT uses the ISA route selector to route the call to the trunk CLI K2KPRA64CLLP2. The call type is specified as public (PUB). The operator access type is NONE and the

---

**PRI Call Routing** (continued)

---

transit network selector is 0. the digit manipulation index is 0 (no digit manipulation needed).

2. Table TRKGRP is accessed using the trunk CLLI from table HNPACONT.RTEREF. Table TRKGRP specifies the LTID of the PRI trunk group (ISDN 445).
3. Table LTCALLS is accessed using the LTID from table TRKGRP and the call type from the ISA selector in HNPACONT.RTEREF. Because a tuple is found in table LTCALLS for ISDN 445 PUB, the call is allowed to route to the trunk group.
4. As shown in the digit translations routes part of the TRAVER, the call routes to trunk K2KPRA64CLLP2. The NPI for the call is E164 (public) and the called digits are 6136221234. Because the call type is public in the ISA route selector, the NSF defaults to NIL. The bearer capability (BC) defaults to speech.

The TRAVER example on the following page shows a call from a line to a PRI trunk.

## PRI Call Routing (continued)

### TRAVER output example for PRI Call Routing

```

Line  Output
      traver I 7221234 6221234 b
1     TABLE LINEATTR
2     0 1FR NONE NSCR 0 613 PKDK L613 TSPS N 0 NIL NIL 00 N
3     TABLE STDPRTCT
4     PKDK (1)
5     . SUBTABLE STDPRT
6     . 622 632 N NP 0 NA
7     TABLE HNPACONT
8     613 128 1 (43) (1)
9     . SUBTABLE HNPACODE
10    . 622 622 LRTE 2 N
11    . SUBTABLE RTEREF
12    . 2 ISA N N N K2KPRA64CLLP2 PUB NONE N 245
13    . TABLE TRKGRP
14    . K2KPRA64CLLP2 PRA 0 NPGDP NCRT ASEQ 7221234 ISDN 445
15    . TABLE LTCALLS
16    . ISDN 445 PUB XLALEC 125 $
17    . EXIT TABLE HNPACONT
18    EXIT TABLE HNPACONT
19    *** TRAVER: SUCCESSFUL CALL TRACE ***
20
21    DIGIT TRANSLATION ROUTES
22    1 K2KPRA64CLLP4 E164 6136221234 NIL_NSF BC SPEECH
23    TREATMENT ROUTES. TREATMENT IS: GNCT
24    1 8OFLO
25    2 LKOUT
26    *** TRAVER: SUCCESSFUL CALL TRACE ***

```

### POTS line to PRI trunk—INWATS call type

The following TRAVER shows an INWATS call. If the ISA route selector is used, and a billing record is required for the call, the call must be routed through a virtual facility group (VFG) to produce a billing record.

The flow through the TRAVERS is as follows:

1. In the first TRAVER, the call routes to table IBNRE. Table IBNRTE specifies a route selector type of IW (INWATS) and routes the call to the VFG named INWPRI.
2. The second TRAVER shows the translations from the VFG to the terminating PRI trunk.
  - a. Table VIRTGRPS is accessed using the VFG name from table IBNRE in the previous leg of the call. Table VIRTGRPS defines the

---

**PRI Call Routing** (continued)

---

- VFG size, the customer group name and NCOS, and the billing number of the call.
- b. Table IBNRTE uses a route selector of ISA to route the call to the trunk group DTCIPRALP1. The call type is INWATS.
  - c. Table TRKGRP is accessed using the trunk CLLI from table IBNRE. Table TRKGRP specifies the characteristics of the terminating trunk group and contains the trunk LTID (ISDN 1020).
  - d. Table LTCALLS is accessed using the LTID from table TRKGRP and the INWATS call type from the ISA selector in table IBNRTE. Because a tuple is found in table LTCALLS for ISDN 1020 INWATS, the call is allowed to route to the trunk group.

The TRAVER example for this call is on the following page.

## PRI Call Routing (continued)

### TRAVER output example for PRI Call Routing

```

Line  Output
      traver l 2231001 2231004 b
1     TABLE IBNLINES
2     HOST 14 1 03 03 DT STN IBN 2231001 NETWORK 0 0 903 $
3     TABLE DNATTRS
4     TUPLE NOT FOUND
5     TABLE DNGRPS
6     TUPLE NOT FOUND
7     TBLE NCOS
8     NETWORK 0 0 0 NCNET $
9     TABLE CUSTHEAD: CUSTGRP,PRELIMXLA,CUSTXLA,FEATXLA,VACTRMT, AND DIGCOL
10    NETWORK NXLA CXNET FXNET 0 DCNET
11    TABLE DIGCOL
12    DCNET 2 RPT
13    NCOS PRELIMXLA name is NIL. Go to next XLA name.
14    CUST PRELIMXLA name is NIL. Go to next XLA name.
15    TABLE IBNXLA: XLANAME CXNET
16    CXNET 223 EXTN Y Y 903 223 7 $
17    TABLE TOFCNAME
18    903 223 1 Y O
19    TABLE DN
20    903 223 1004 T IBNRTE 907
21    TABLE DNATTRS
22    TUPLE NOT FOUND
23    TABLE DNGRPS
24    TUPLE NOT FOUND
25    TABLE IBNRTE
26    907 IW 14 223 INWPRI 35
27    . TABLE DIGMAN
28    . 35 (CL BEG) (REM 7) (INC 7306999) (CL BEG)
29    . EXIT TABLE DIGMAN
30    EXIT TABLE IBNRTE
31    *** TRAVER: SUCCESSFUL CALL TRACE ***
32
33    DIGIT TRANSLATION ROUTES
34    1 VFG: INWPRI          7306999      ST
35
36    TREATMENT ROUTES. TREATMENT IS: GNCT
37    1 T120
38    *** TRAVER: SUCCESSFUL CALL TRACE ***

```

The second TRAVER translates from the VFG to the trunk group.

**PRI Call Routing (end)****TRAVER output example for PRI Call Routing**

Line	Output
	<b>traver v inwpri 7306999 b</b>
1	TABLE VIRTGRPS
2	INWPRI SIZE 2 IBN 9032231000 NETWORK 0 0 0 N N N \$
3	TABLE NCOS
4	NETWORK 0 0 0 NCNET \$
5	TABLE CUSTHEAD: CUSTGRP,PRELIMXLA,CUSTXLA,FEATXLA,VACTRMT, AND DIGCOL
6	NETWORK NXLA CXNET FXNET 0 DCNET
7	TABLE DIGCOL
8	DCNET 7 RPT
9	NCOS PRELIMXLA name is NIL. Go to next XLA name.
10	CUST PRELIMXLA name is NIL. Go to next xla name.
11	TABLE IBNXLA: XLANAME CXNET
12	CXNET 7 ROUTE N N 0 N 7 7 POTS N T IBNRTE 908
13	TABLE DIGCOL
14	POTS specified:POTS digit collection
15	TABLE IBNRTE
16	900 ISA N N N DTCIPRALP1 INWATS E164 0
17	. TABLE TRKGRP
18	. DTCIPRALP1 PRA 0 NPDGP NCRT ASEQ N (ISDN 1020) \$
19	. TABLE LTCALLS
20	. ISDN 1020 INWATS XLAIBN 263 COREREGA 1 0 \$
21	EXIT TABLE IBNRTE
22	*** TRAVER: SUCCESSFUL CALL TRACE ***
23	
24	DIGIT TRANSLATION ROUTES
25	1 DTCIPRALP1 E164 7306999 IWT BC SPEECH
26	TREATMENT ROUTES. TREATMENT IS: GNCT
27	1 T120
28	*** TRAVER: SUCCESSFUL CALL TRACE ***

**SERVORD**

PRI Call Routing does not use SERVORD.

---

## PRI Call Screening

---

### PRI Call Screening ordering codes

Functional group ordering codes: NI000015

Functionality ordering codes: not applicable

### Release applicability

NA008 and up.

### Description

PRI Call Screening provides the functionality for calling number (CGN) screening, redirecting number (RN) privacy, screening, billing, and delivery for NIPRI. PRI Call Screening is compliant to TR-NWT-001187 (ISDN Calling Number Identification Services for Primary Rate Interfaces, Issue 1, March 1992, plus Revision 1, December 1994).

This feature provides the following:

- Ensures a returnable calling party number
- Ensures correct distance billing for 800/888 calls
- Ensures that invalid numbers do not enter the public network

### Operation

Table DNSCRN provides information is used by call processing to perform call screening and call validation on specified directory numbers. When calling line identification (CLI) is enabled, attributes CLILTID1 and CLILTID2 identify LTID tuples in Table LTDEEF to be used by call processing for screening, editing, and redirection purposes.

PRI Call Screening includes redirecting number (RN) screening. RN screening interacts with CGN screening. RN screening requires datafill in Table LTDATA to define CGNs from RNs. RN screening is only applied to NIPRI interfaces.

Table LTDATA stores the following data associated with the LTID.

- RN screening requirements
- Information to enable editing of the RN
- A default presentation indicator (PI)

PRI Call Screening enhances the PRI redirecting number delivery (RND) service by providing the capability to suppress or override the presentation of one or both redirecting party numbers. RND, for incoming calls on an NIPRI,



controls presentation of DN's of the first or second instance of redirection to the called party.

RND determines what redirection information is delivered across the PRI. One or two sets of RND information can be independently screened based on their respective outgoing trunk and/or the incoming privacy indicator. The first set of RND information is associated with the first instance of redirection, and the second set of RN information (when present) is associated with the latest instance of redirection.

PRI Call Screening with RND provides for RND privacy. The RND DN may not be displayed at the called party premises due to any of the following reasons:

- The RND is not available. This occurs, when interworking with per-trunk signaling (PTS) trunks.
- The redirecting party has restricted presentation of the DN with the PI.
- A subscription on the originating side to suppress the presentation of the DN. Suppression subscriptions are controlled on an individual PRI basis.
- An active subscription on the terminating side of the PRI to restrict presentation of the RND DN to the called party.

When the incoming message has no PI values, the results are based on the screening results and subscription of privacy against the interface. When the incoming message has PI values, the results are based on the screening results and PI values. PI is applied to both RNs independently and the presentation or suppression of one does not affect the other.

PRI Call Screening enhances the NIPRI billing function by introducing the billing number selection (BNS) parameter to determine the billing number for AMA recording. The BNS parameter is assignable for each PRI. BNS allows a special billing number (SBN), a user provided but not screened redirecting number (UPNS), or a user provided redirecting number that passed screening to be recorded in the AMA billing record.

The following figure shows an example of call screening and redirected number (RN) screening. For example, if a subscriber's DN is 9992-3333 and does not have this feature, the DN displays to the called party regardless of whether the call is internal or external to the private branch exchange (PBX). When the subscriber has this feature and calls within the PBX, the DN still displays to the called party. However, when the subscriber calls outside the PBX, the DMS-100 switch sends any number to which the subscriber has previously prescribed to the called party's display, for example, the company's main DN 992-1000.

Call screening and redirected number screening

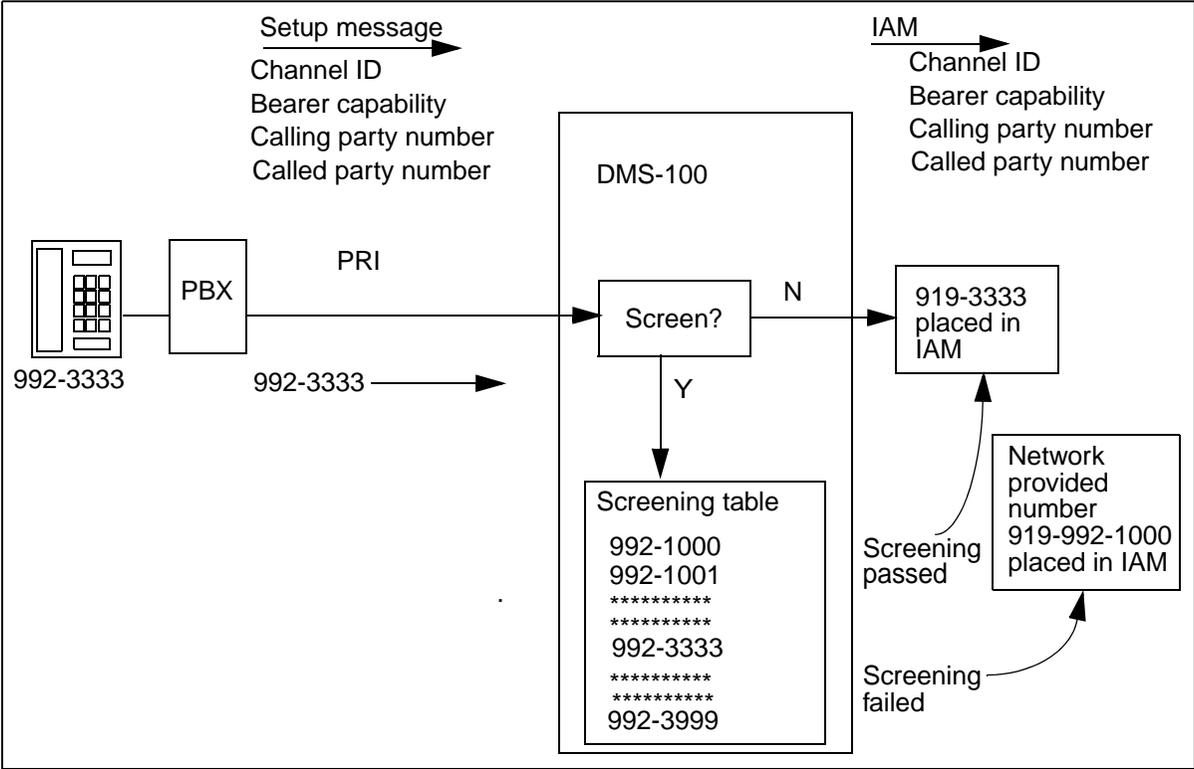

The following figure shows RN editing and screening functionality flow.

**RN editing and screening functionality**

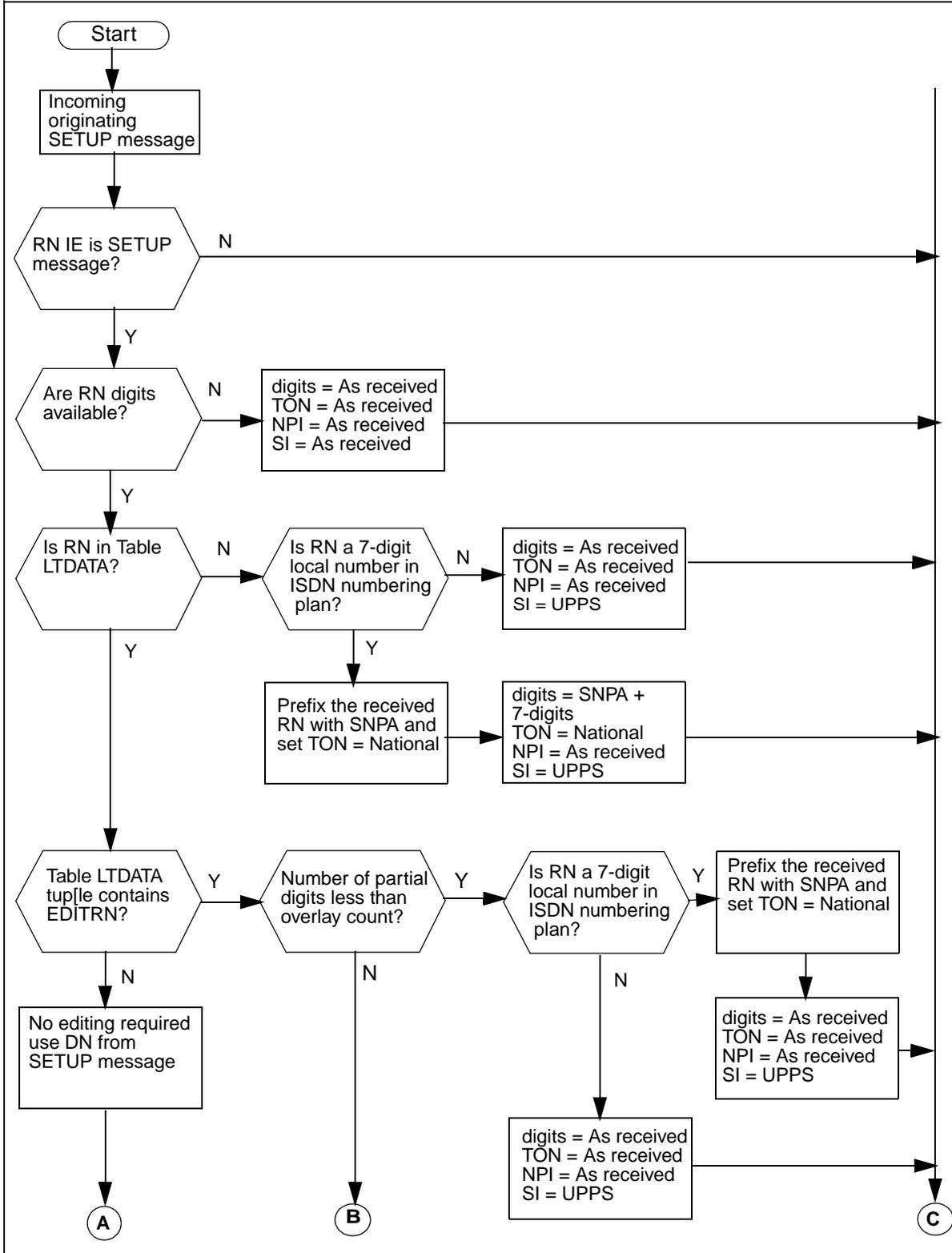

RN editing and screening functionality

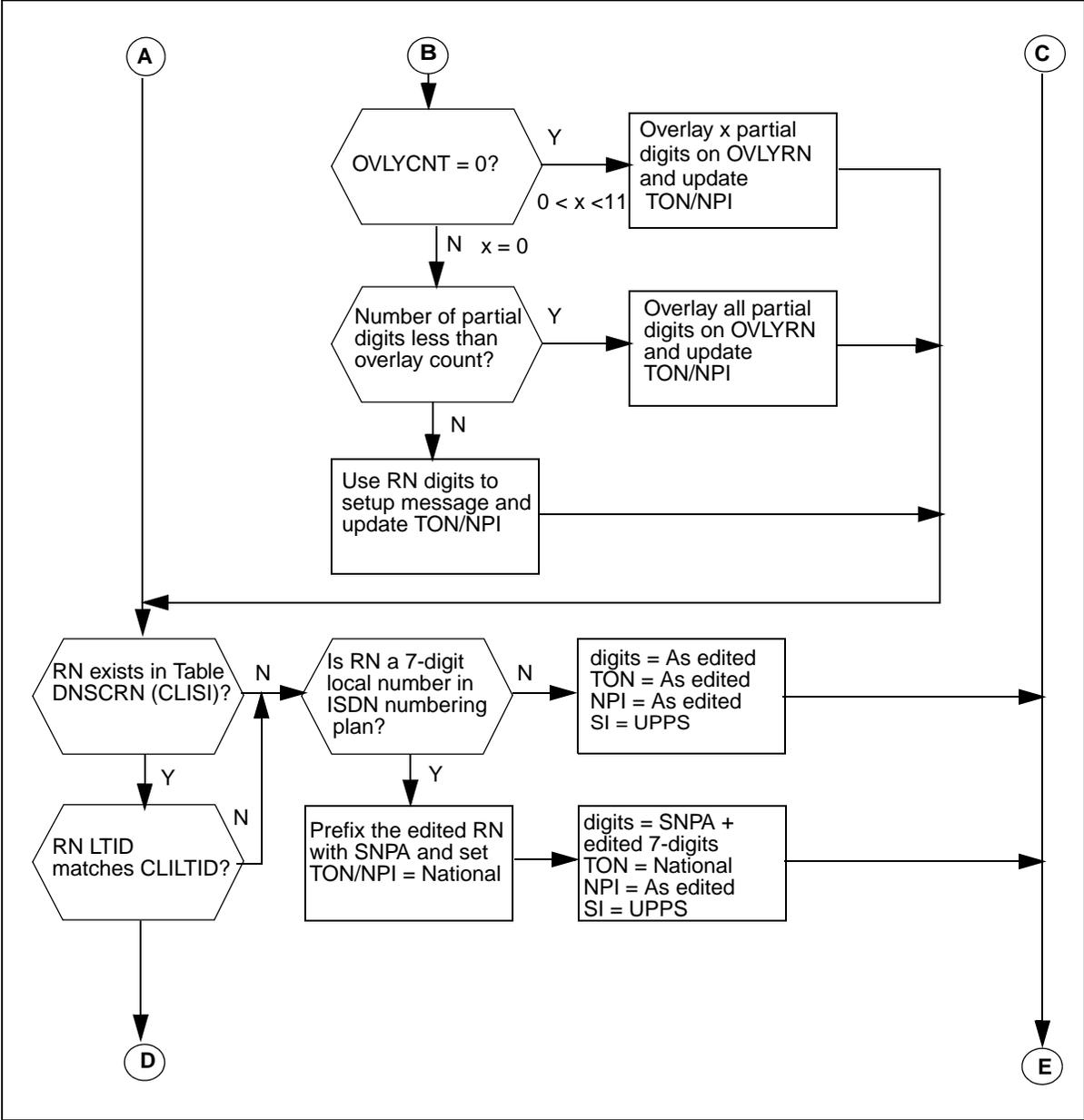

**RN editing and screening functionality**

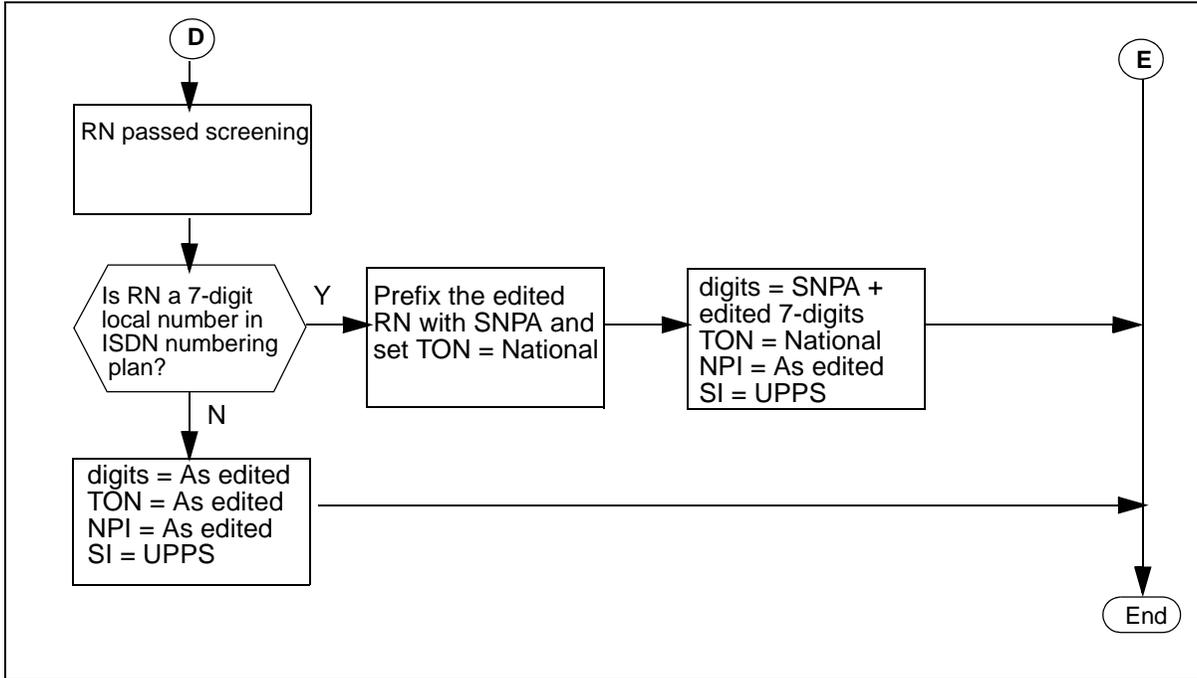

The following figure shows the CGN editing and screening functionality (NI variant) flow for PRI Call Screening.

CGN editing and screening functionality (NI variant)

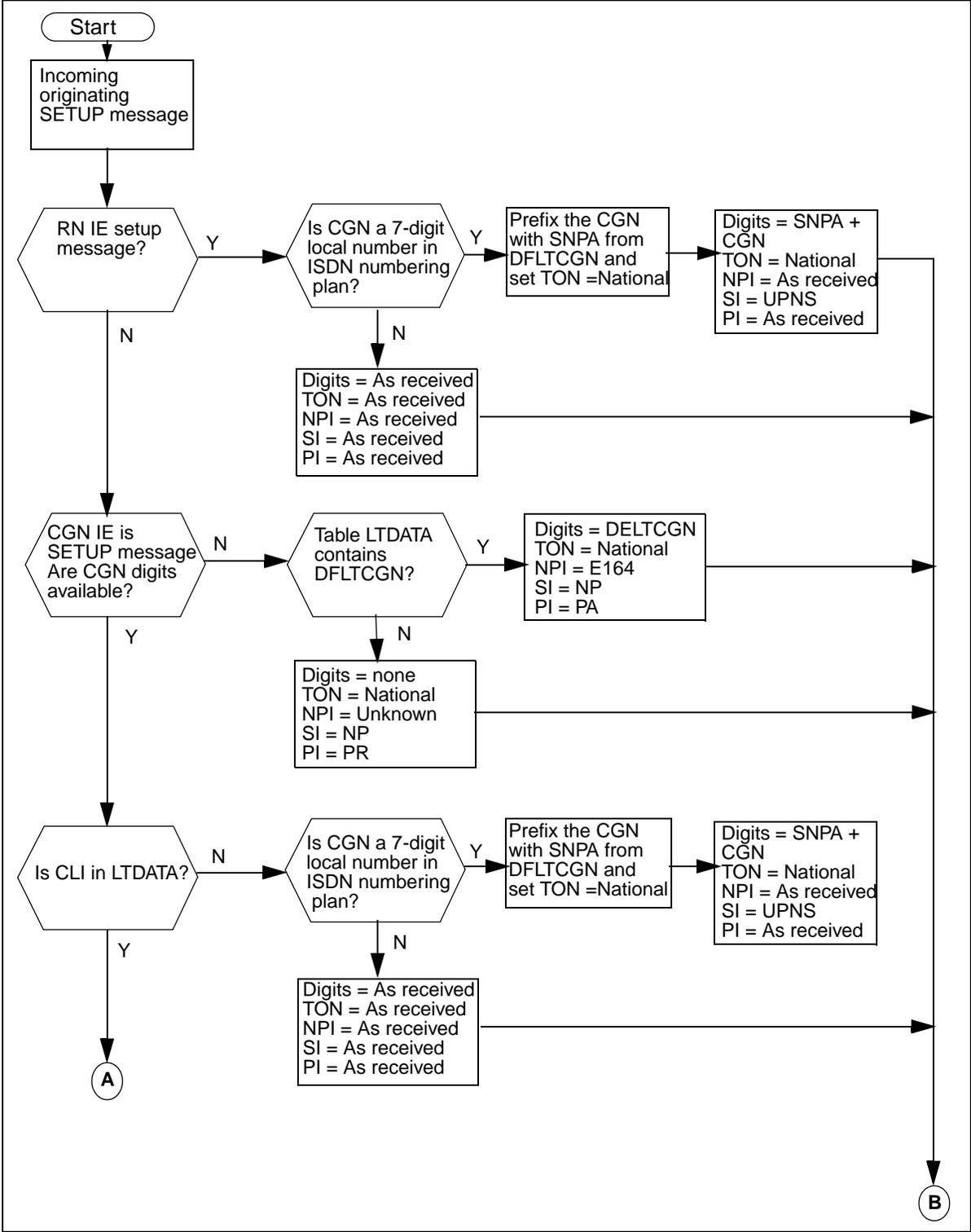

CGN editing and screening functionality (NI variant)

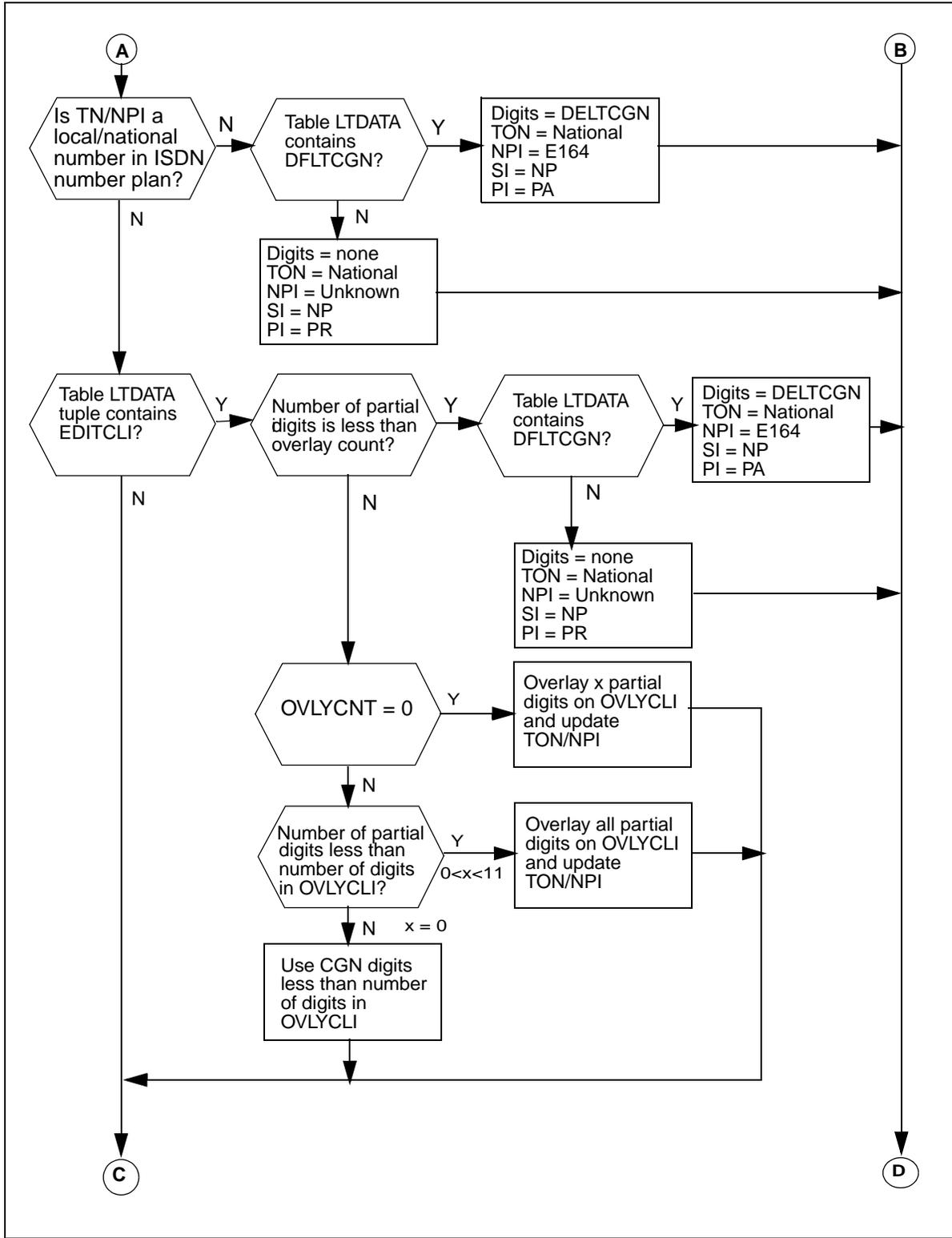

CGN editing and screening functionality (NI variant)

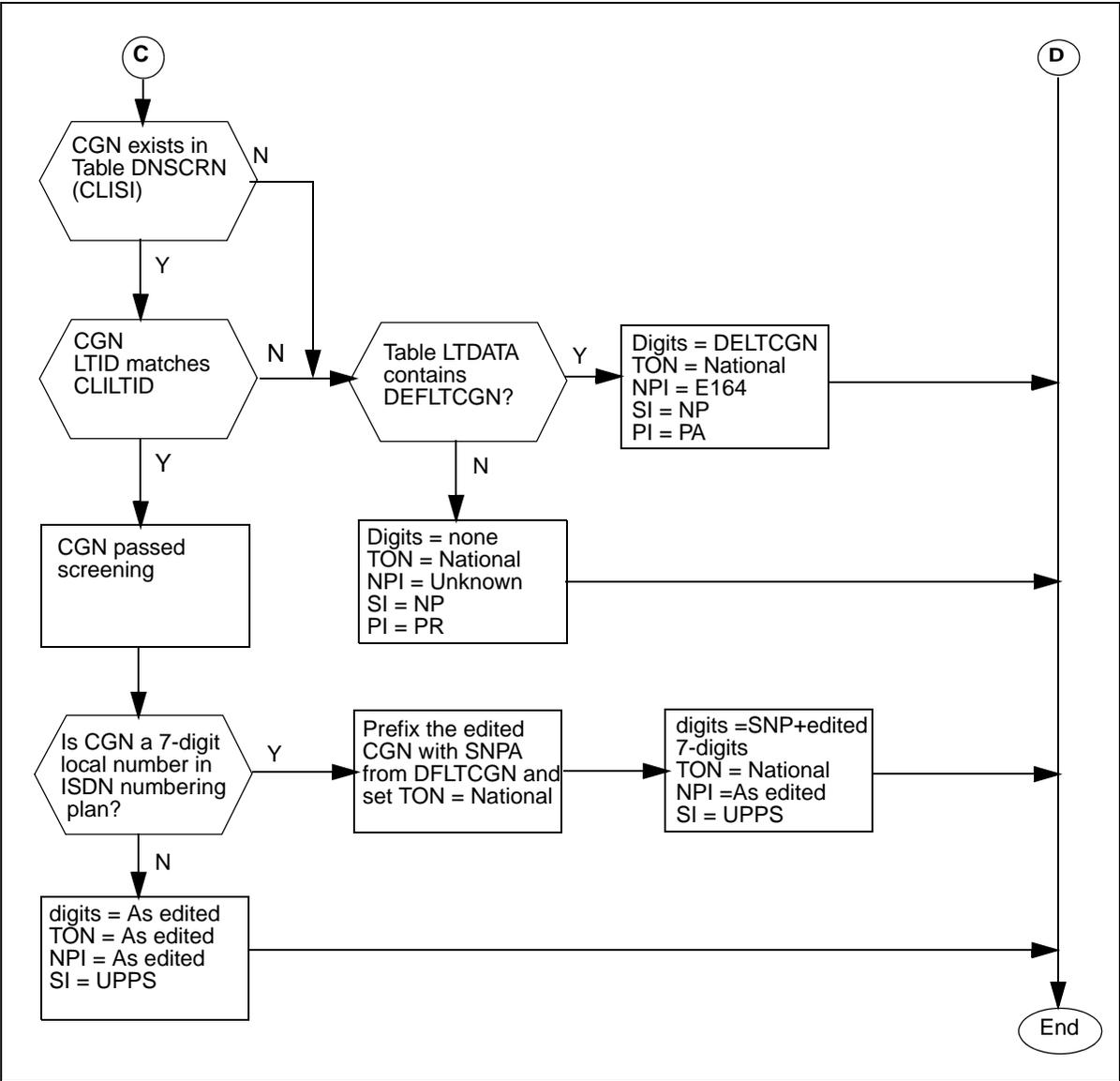

The following figure shows the billing number determination flow for PRI Call Screening.



**Billing number determination flow**

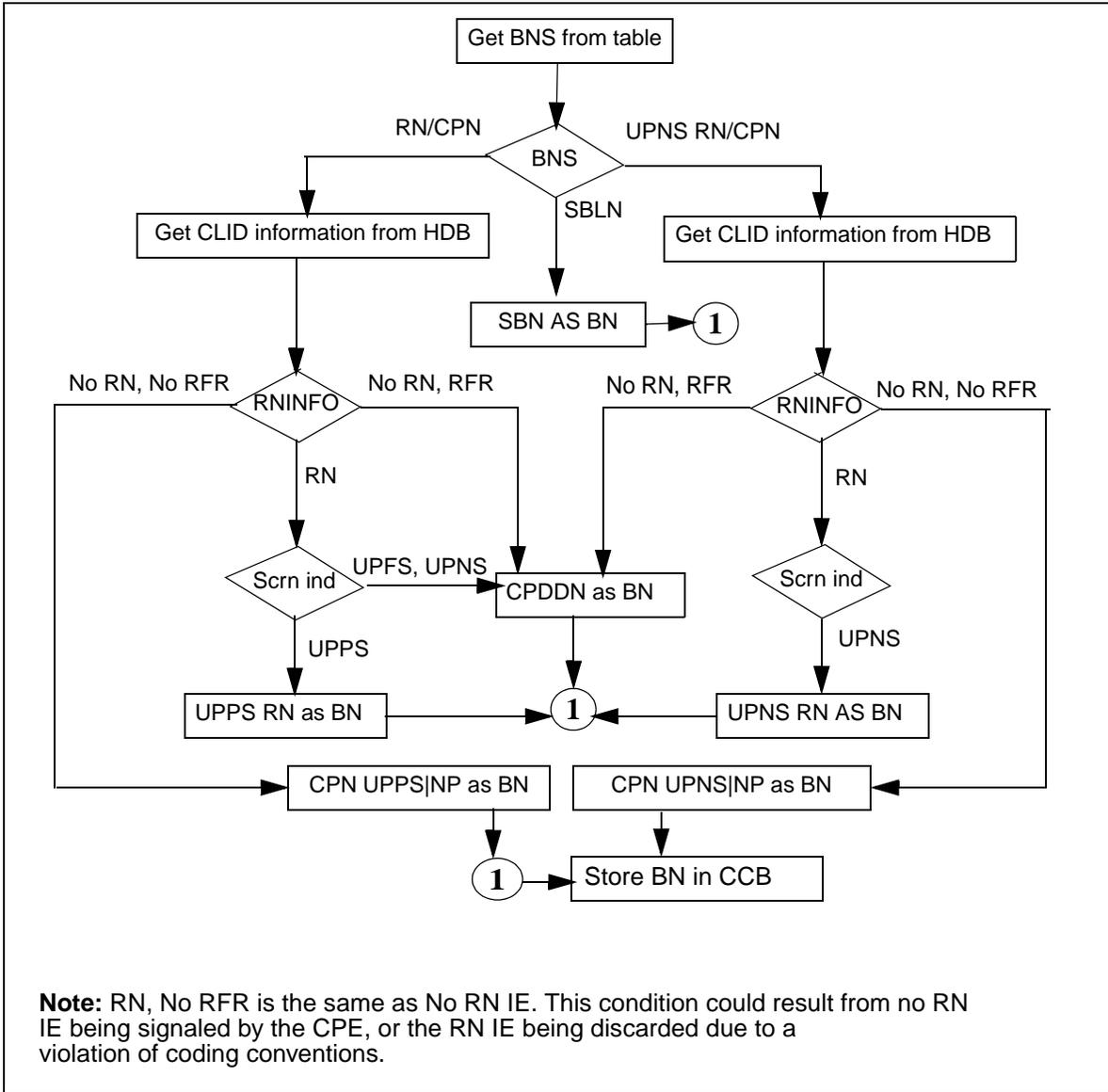

The following figure shows the call flow for redirected number delivery.

## Redirecting number delivery flowchart

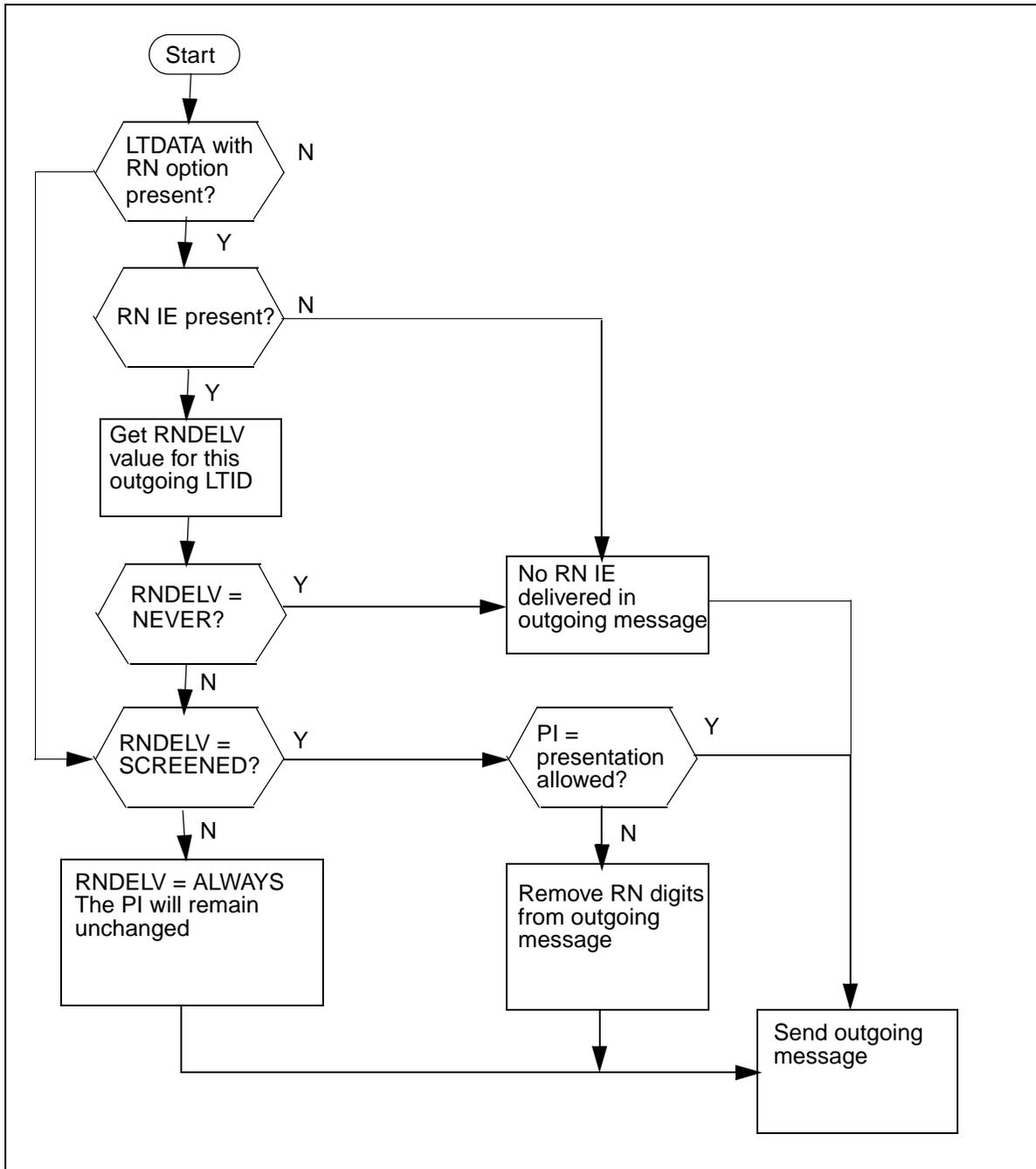

The following figure shows the flow for redirecting number privacy.

Redirecting number privacy

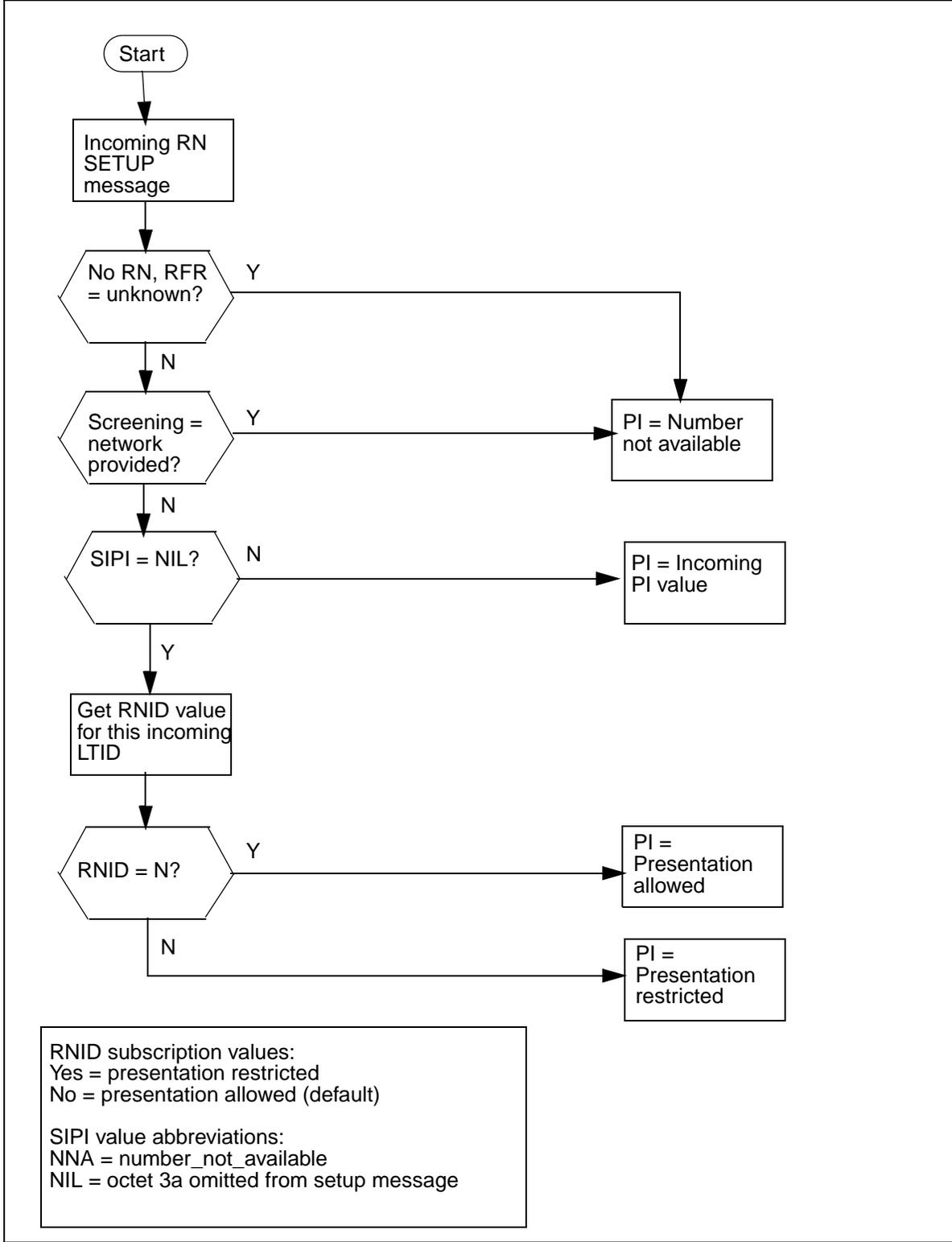

---

## Translations table flow

The PRI Call Screening translations tables are described in the following list:

- In Table LTDEF (logical terminal definitions) the tuples defining LTIDs for screening must be datafilled with subfield VARIANT = NIPRI or NTNAPRI and respective ISSUES before datafilling the referencing OPTION CLILTID1 or CLILTID2 in Table DNSCRN.
- Table LTDATA (logical terminal data) stores service-related data associated with the logical terminal identifier (LTID). Field LDTKEY consists of three parts: subfield logical terminal group (LTGRP), subfield logical terminal number (LTNUM), and subfield data type (DATATYPE).
- Subscription parameters related to ISDN PRI, such as calling party number delivery, are supported in Table LTDATA. With PRI Call Screening, the following subscription parameters are added to Table LTDATA:
  - In subfield DATATYPE, add RN (redirection number) and OPTION EDITRN (edit RN), and subfields OVLYRN (overlay RN), NPI (network plan indicator), and TON (type of number).
  - When subfield DATATYPE = SERV, add entry RNID (RN identification) and refinement SUPPRESS to subfield OPTION.
  - When subfield DATATYPE = SERV, add entry RNDELV (RN delivery) screening and refinements. Add ALWAYS, SCREENED, OR NEVER to subfield DELIVER.
  - When subfield DATATYPE = SERV, add entry BNS (billing number selection) to subfield OPTION.
- In Table DNSCRN, field ATTROPTS is checked for (CLISI), calling line identifier screening information, indicating if the DN can be used for screening purposes. When in field ATTROPTS CLILTID is datafilled for the DN and the call matches the CGN or RN service requirements of the LTIDs in LTDATA, then screening passes.

The PRI Call Screening translation process is shown in the flowchart that follows.

Table flow for PRI Call Screening

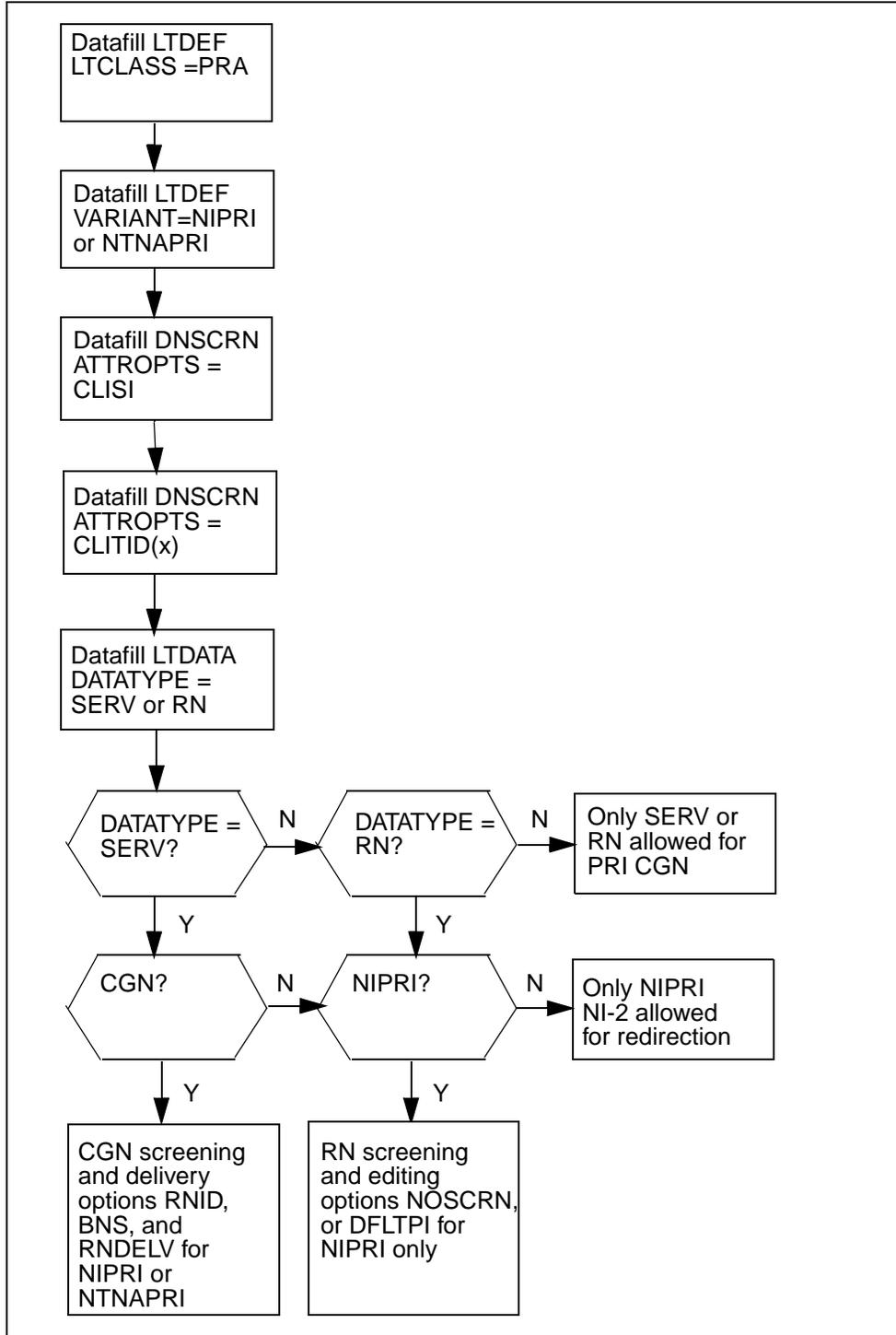

The following table lists the datafill content used in the flowchart.

#### Datafill example for PRI Call Screening

Datafill table	Example data
LTDEF	ISDN 20 B PRA 20 NTNAPRI V1 NIL (NOPMD) ISDN 20 2BD PRA 20 NIPRI NI2VI NIL (NOVOICE)
LTDATA	ISDN 20 SERV SERV N Y ALWAYS ALWAYS RNID Y ISDN 20 RN RN EDITRN 613 E164 NATL 0
DNSCRN	7751639 CLSI SLILTID CKT PRAOG 18

#### Limitations and restrictions

The following limitations and restrictions apply to PRI Call Screening:

- RN services are provided for NI-2 variants only.
- Subscription of RN/CPN preferred as the billing number (BN) parameter is not assigned per call type.
- Subscription of special BN parameter is not assigned by call type.
- Subscription of UPNS RN/CPN preferred as the BN is not assigned by call type.
- Detailed AMA for network provided (NP) per-interface is not supported.
- For an originating NIPRI (NI-2), Telcordia requires vendors to preserve the incoming presentation indicator (PI) value. When the incoming PI is NIL (3a is missing from the calling party number (CPN) information element in the SETUP message), the PI for the CPN will be altered according to the INCLID value. Otherwise, the INCLID parameter will not affect the PI for the CPN. This must be done on an individual line basis, that is, the PBX must send a NIL value for the CPN PI for the INCLID value to be used.

#### Billing

PRI Call Screening enhances the NIPRI billing function by introducing the billing number selection (BNS) parameter to determine the billing number for AMA recording. The BNS parameter is assignable for each PRI. BNS allows a special billing number, or a user-provided redirecting number that passed screening to be recorded in the AMA billing record.

## Datavfilling Table LTDATA

The following table shows the datavfill specific to PRI Call Screening for Table LTDATA. Only those fields that directly apply to PRI Call Screening are shown.

### Datavfilling Table LTDATA

Field	Subfield or refinement	Entry	Explanation and action
LTKEY		See subfields	Logical Terminal Data Key. This field consists of subfields LTGRP, LTNUM, and DATATYPE.
	LTGRP	Alphanumeric (maximum 8 characters)	Logical Terminal Group. Enter the Logical Terminal Group (LTG) name.
	LTNUM	1–1022	Logical Terminal Number.
	DATATYPE	DN, SERV	Logical Terminal Data Type. <ul style="list-style-type: none"> <li>• Enter DN for a default CGN. The default CGN is a part of the screening capability of NIPRI. DN has the default CGN as a mandatory datavfill. Enter the number that is to be used when the original number fails screening.</li> <li>• Enter SERV for service-related data associated with a logical terminal identifier (LTID) or PRA interface.</li> </ul>
LTDRSLT		See subfield	Logical Terminal Result. This field consists of subfield DATATYPE.
	DATATYPE	DN, SERV	Logical Terminal Data Type. Enter the logical terminal data type as follows: <ul style="list-style-type: none"> <li>• Enter DN for directory number.</li> <li>• Enter SERV for service-related data associated with a logical terminal identifier (LTID) or PRA interface.</li> </ul>

**Table LTDATA, DATATYPE = SERV**

When the entry in field DATATYPE is SERV, datafill subfields AUDTRMT, CGNREQD, CGNDELV, CDNDELV, and OPTION.

**Field descriptions for conditional datafill (Sheet 1 of 2)**

Field	Subfield or refinement	Entry	Explanation and action
	AUDTRMT	Y, N	<p>Audible Treatments.</p> <p>Enter Y or N to enable or disable in-band treatments for originating PRI calls with bearer capability (BC) of speech or 3.1kHz audio.</p> <p>Applies to: VACT, UNDN, BLDN, PODN, CONF, MHLN, ATBS, TESS, TRBL, DNTR</p>
	CGNREQD	Y, N	<p>Calling party number required. Enter Y to indicate that the CGN must be provided. Otherwise, enter N.</p>
	CGNDELV	ALWAYS, NEVER, SCREENED	<p>Calling Party Number Delivery. This field indicates when the CGN is delivered to the called interface. Enter one of the following:</p> <p>ALWAYS indicates the actual CGN with the PI is sent.</p> <p>NEVER indicates the CGN with the PI is not sent.</p> <p>SCREENED indicates that when the PI is private, the CGN is not sent (it is replaced with asterisks).</p> <p>The default for this field is SCREENED.</p>
	CDNDELV	NEVER, ALWAYS	<p>Called Party Number Delivery. This field determines whether the called party number is delivered to the called interface.</p>



**Field descriptions for conditional datafill (Sheet 2 of 2)**

Field	Subfield or refinement	Entry	Explanation and action
	OPTION	BNS, EDITRN, RNDELV, RNID	Option. Enter one of the following options: Enter BNS and the refinements SBN (special billing number from Table TRKGRP), RN/CPN (user provided redirected number screening), or UPNS RN/CPN (default value). <ul style="list-style-type: none"> <li>• Enter EDITRN and datafill subfields OVLYRAN, NPI, TON, and OVLYCNT.</li> <li>• Enter RNDELV and datafill subfield DELIVER with redirected number screening refinements.</li> <li>• Enter RNID and datafill refinement SUPPRESS.</li> </ul>
	OVLYRN	0–9 (vector of maximum 18 digits)	Overlying Redirected Number. This field converts a partial redirected number to a complete number by associating a partial RN with an overlying RN.
	NPI	E164	Numbering Plan Identifier. Enter the numbering plan identifier associated with field OVLYARN.
	TON	NATL, LOCAL	Type of Number. Enter the type of number associated with field OVYCLI.
	OVLYCNT	0–18	Overlying Count. Enter the number of least significant digits from a partial CLI that are overlaid on the least significant digits of the field OVLYRN. A value of 0 (zero) indicates all the digits from the partial RN are overlaid.

**Datafill example for Table LTDATA**

The following example shows sample Datafill for Table LTDATA.

**MAP display example of Table LTDATA**

LTKEY	LTDRSLT
ISDN 20 SERV	SERV N Y ALWAYS ALWAYS RNID BNS \$
ISDN 20 RN	RN EDITRN 613 E164 NATL 0 \$

**Datafilling Table DNSCRN**

The following table shows the datafill specific to PRI Call Screening for Table DNSCRN. Only those fields that apply directly to PRI Call Screening are shown.

**Datafilling Table DNSCRN (Sheet 1 of 2)**

Field	Subfield or refinement	Entry	Explanatin and action
DN		See subfield	Directory Number. This field consists of subfield DNDIGS.
	DNDIGS	Up to 24 digits	Directory Number Digits. Enter the DN that represents the calling line number or the called line number.
ATTROPTS		NIL, CLILTID1, CLILTID2, CLISI	<p>Screening Attribute Options. Enter the screening attributes.</p> <p><b>CLILTID1 and CLILTID2 attributes are used by call processing for screening purposes. Each of these attributes can accommodate up to six LTIDs for each DN. For North American PRI, the LTID has to be datafilled in Table LTDEF with the variant NIPRI (NI-2 PRI) or NTNAPRI (Nortel North American PRI) before it can be datafilled in Table DNSCRN. When the entry is CLILTID1 or CLILTID2, datafill subfields LTGRP and LTNUM.</b></p> <p>CLSI indicates the DN can be used to identify the origin of the call.</p>

**Datafilling Table DNSCRN (Sheet 2 of 2)**

Field	Subfield or refinement	Entry	Explanatin and action
	LTGRP	Up to 8 characters	Logical Terminal Group. Enter the logical terminal group of the user. Valid group names are listed in field GROUP of Table LTGRP. For ISDN terminals, the name of the group is ISDN.
	LTNUM	Numeric (1-1022)	Logical Terminal Number. Enter the logical terminal number within the group.

**Datafill example for Table DNSCRN**

The following example shows sample datafill for Table ATTROPTS.

**MAP display example of Table DNSCRN**

DN	ATTROPTS
7751639	(CLSI CLILTID1) CKT PRAOG 18 \$

**Translation verification tools**

PRI Call Screening does not use translation verifications tools.

**SERVORD**

PRI Call Screening does not use SERVORD.

**DNSCRNCI CI command level**

In order to simplify datafill and attribute modification for large groups of DNs, the CI command DNSCRNCI allows the craftsperson to enter the following

subcommands under DNSCRNCI: HELP, ADDRANGE, DELRANGE, UPDATTR, FINDATTRS, and QUIT.



### WARNING

The ADDRANGE and DELRANGE commands write to the journal file and can cause it to overflow, hence entries will be lost in the journal file. To ensure this does not occur, please verify sufficient disk space for the journal file volume exists before using these commands.

The sections below provide detailed information on these subcommands

## ADDRANGE

The ADDRANGE command allows the craftsman to datafill a range of digits to the specified attributes in Table DNSCRN. The FROM D TO D parameters must be the same length.

### ADDRANGE command for DNSCRNCI

```
>DNSCRNCI
DNSCRNCI :
>ADDRANGE
FROMD: 6137221015
TOD: 6137221020
ATTROPTS: CLISI
WRITEMODE: NOREPLACE
>
```

The example in Figure demonstrates the ADDRANGE command in the prompt mode where each parameter is queried by the system. This example will set the DNs in the range from 6137221015 to 6137221020 inclusive, with the same length DN of 10, to CLISI. Specifically, DNs 6137221015, 6137221016, 6137221017, 6137221018, 6137221019, and 6137221020 will be datafilled in Table DNSCRN with screening attribute CLISI.

If tuples in the specified range already exist in Table DNSCRN, the existing tuples will not be overwritten. In order to overwrite existing tuples in the range, the REPLACE option must be used as part of the ADDRANGE command.

### **ADDRANGE command with no prompt**

```
>DNSCRNCI  
  
DNSCRNCI :  
  
>ADDRANGE 6137221015 613722020 (CLISI) $ REPLACE
```

The example in Figure demonstrates the ADDRANGE command in the non-prompt mode.

This example will set the DNs in the range from 6137221015 to 6137221020 inclusive, with the same length DN, to CLISI. Tuples which have already been defined in this range will be overwritten. The craftsman is prompted with a warning message when the REPLACE option is specified.

### **DELRANGE**

The DELRANGE command will delete all the defined tuples within the specified range of the same length DNs.

#### **DNSCRNCI command DELRANGE**

```
>DNSCRNCI  
  
DNSCRNCI :  
  
>DELRANGE 6137221010 6137221020
```

The example in Figure demonstrates the DELRANGE command in the non-prompt mode.

This example will delete all the tuples defined in the range 6137221010 and 6137221020 inclusive which have a DN length of 10 (i.e. if DN 10101 is defined it will not be deleted). The craftsman is prompted with a warning message when the DELRANGE command is specified

### **UPDATTR**

The UPDATTR command is used to update a single attribute over a range of DNs in Table DNSCRN. It can perform three basic tasks over a specified range. It can modify an existing attribute in a tuple, it can add an attribute to a

tuple, or it can delete an attribute from a tuple. There are four parameters associated with the UPDATTR command. They are:

- <FROMD> - specifies the beginning of the DN range that is to be considered (inclusive)
- <TOD> - specifies the end of the DN range that is to be considered (inclusive)
- <OLDATTR> - specifies the attribute to be updated
- <NEWATTR> - specifies the new attribute that will replace the old one

To delete an attribute over a range of tuples, the attribute to be deleted is specified in <OLDATTR> and a \$(or NIL) is specified in <NEWATTR>. To add an attribute over a range of tuples, the attribute to be added is specified in <NEWATTR> and a \$(or NIL) is specified in <OLDATTR>.

The UPDATTR command allows the craftsperson to update a single attribute over a range of DNs in table DNSCRN. The DN is not affected, only an attribute associated with it. The FROMD and TOD parameters must be the same length. The attribute to be changed is specified by OLDATTR. The new attribute that is to replace the old one is specified by NEWATTR. If the attribute that is to be updated has any data associated with it, then the attribute will be changed only if the attribute and its data match what is specified by the user in OLDATTR.

### **DNSCRNCI comand UPDATTR**

```
Assume the following DNs exist in Table DNSCRN

    6137222000 (CLISI) $
    6137222001 (CLISI) $
    6137222002 $

>DNSCRNCI

DNSCRNCI:

>UPDATTR

FROMD: 6137222000
TOD: 6137222002
OLDATTR: CLISI
NEWATTR: NIL

SPECIFIED ATTRIBUTE IN TUPLE RANGE WILL BE
MODIFIED.

DO YOU WISH TO CONTINUE?
PLEASE CONFIRM ("YES" OR "NO")

>YES
```

The above example demonstrates the UPDATTR command in prompt mode. The range is from 6137222000 to 6137222002, inclusive. The above example removes the CLISI attribute from all the numbers in the range specified.

### **FINDATTRS**

The FINDATTRS command will search table DNSCRN based on the given attributes. It is a general tool that works for all the attributes in table DNSCRN. The FINDATTRS command contains the following subcommands:

- HELP
- SEARCH
- SEARCHALL
- SET
- QUIT

Figure shows the syntax of the FINDATTRS command.

### The syntax of the FINDATTRS command

```

HELP          - Prints a list of FINDATTRS commands
                and a description of each command
SET           - Sets up environment for the SEARCH command
                Displays current environment when no parameters
                specified
Parms: [<OPTIONS>... {FINDMODE <MODE> {EXACT,

                STARTAT <DN> STRING,
                STOP <OPT> {AT <DN> STRING,
                AFTER <NUM_OF_TUPLES> {1 TO 8000000}},
                DISPLAY <NUM_OF_TUPLES> {1 TO 8000000}},
                SHOW <DN/TUPLE> {DN,
                                TUPLE}}}]
DEFAULTS     - Initializes the options for the SEARCH
                command with default values
SEARCH       - Searches table DNSCRN for specified attributes
                <ATTROPTS> - vector of upto 25 attributes
SEARCHALL    - Searches table DNSCRN for attributes CLILTID1
                CLILTID2, SCRGRP1, and SCRGRP2
Parms: <LTGRP> STRING
        <LTNUM> {1 TO 1022}
QUIT        - Quits FINDATTRS increment

```

#### HELP subcommand

This command prints a list of FINDATTRS commands and a description of each command.

#### SEARCH subcommand

This command accepts as a parameter the attributes to search for in table DNSCRN. The SEARCH command will scan table DNSCRN and display tuples datafilled with the attributes specified in the ATTROPTS parameter of the command. Figure shows an example of the SEARCH command.



### Example of the SEARCH subcommand

```
dnscrnci
WARNING: ADDRANGE and DELRANGE commands write to the
        journal file and can cause it to overflow,
        hence entries will be lost in the journal
        file. To ensure this does not occur, please
        verify sufficient disk space for the journal
        file volume exists before using these commands.
DNSCRNCI:
>findattrs
FINDATTRS:
>SET
FINDMODE - EXACT
STARTAT  - 1
STOP      - AFTER 5
DISPLAY  - 5
SHOW     - TUPLE
>search cliltid1 isdn 1 $ $
DN ATTROPTS
-----
6137221234 (CLISI ) (CLILTID1 (ISDN 1)$) $

SEARCH summary
-----
Reason for Stopping - Requested number of tuples scanned (STOP AFTER)
Number of tuples displayed - 1
Last search attempted on DN - 6137221234
```

### SEARCHALL subcommand

This command accepts an LTID to search all the attributes of table DNSCRN. The user is prompted for the LTID, and the command will scan all attributes of table DNSCRN. Figure shows an example of the SEARCHALL command.

### Example of the SEARCHALL command

```

>SEARCHALL isdn 1
DN ATTROPTS
-----
1 (CLISI ) (CLILTID1 (ISDN 1) (ISDN 3) (ISDN 7) (ISDN 8) (ISDN 26)
(ISDN 51)$) (CLILTID2 (ISDN 104) (ISDN 105) (ISDN 106) (DWS 2) (DWS 4)
(DWS 6)$) $

6134557045 (CLISI ) (SCRGRP2 (TEST)$) $

6134559898 (CLISI ) (SCRGRP1 (PRITEST)$) $

6137221111 (CLISI ) (CLILTID2 (ISDN 1) (ISDN 105)$) $

6137221234 (CLISI ) (CLILTID1 (ISDN 1)$) $

SEARCH summary
-----
Reason for Stopping - Requested number of tuples displayed (DISPLAY)
Number of tuples displayed - 5
Last search attempted on DN - 6137221234

```

### SET subcommand

The SET subcommand sets up the search environment. Parameters of the SET subcommand are:

- FINDMODE
- STARTAT
- STOP
- DISPLAY
- SHOW
- QUIT

**FINDMODE** These are the two modes for searching. An EXACT search takes the data associated with an input attribute literally and search the table. The sequence of given data under its attribute is significant. A WILD search finds all the combinations based on the given attribute data. For example, consider the following two tuples in table DNSCRN:

**Table DNSCRN datafill examples**

DN	ATTROPTS
1234567	(CLILTID1 (ISDN 5) (ISDN 6) (ISDN 8) \$)\$
7654321	(CLILTID1 (ISDN 5) (ISDN 8) \$) \$

For a search command: SEARCH CLILTID1 ISDN 5 ISDN 8,

- An EXACT search would only find the second tuple, but not the first one.
- A WILD search would find both tuples.

For EXACT search, the sequence of (ISDN 5, ISDN 8) under attribute CLILTID1 is significant. The sequence of attributes given in the SEARCH command is not significant for both EXACT search and WILD search.

*Note:* This parameter is only applicable to the SEARCH subcommand.

**STARTAT** This command is used to specify the DN to start the search at. The given DN does not have to be present in the table.

**STOP** This command is used to specify how to stop the search. AT specifies which DN to stop at. AFTER specifies how many tuples in the table to search for.

*Note:* This parameter will be valid only when STARTAT has been defined.

If AT is specified, the search would stop after the given DN is searched. For AT, the given DN does not have to be present in the table. In this case, no tuple after the given DN, if any, would be searched.

If AFTER is specified, the search stops after the specified number of tuples are searched.

**DISPLAY** This command specifies how many found tuples to display,

**SHOW** This command specifies what to display for a found tuple. DN indicates only DN is displayed. TUPLE indicates the entire tuple is displayed.

#### **DEFAULTS subcommand**

Different from the SET command, the FINDATTRS command DEFAULTS sets the search environment to system defaults. They are:

- FINDMODE: exact
- STARTAT: NIL (if the table is empty) or the DN of the first tuple
- STOP: AFTER 0 (zero, if the table is empty) or the total number of tuples in the table
- DISPLAY: the lesser of 10 and the total number of tuples in the table. If the table is empty, DISPLAY is set to 0.
- SHOW: tuple

## **PRI Calling Line Identification Blocking**

---

### **Ordering code**

Functionality group ordering code: NI000022

Functionality ordering code: Not applicable

### **Release applicability**

BCS36 and up

### **Prerequisites**

To operate, PRI Calling Line Identification Blocking (CLID) has the following prerequisites:

- NI0 ISDN Base, NI000007
- MDC - MDC Minimum, MDC00001

### **Description**

PRI Calling Line Identification Blocking is made up of CLID presentation and restriction.

CLID presentation is a service offered to the called party to identify the origin of a call. The called party is provided with the ISDN number of the calling party.

CLID restriction is a service offered to the calling party. The calling party's ISDN number is not presented to the called party. The restriction is for individual calls or all calls.

An integral function of CLID presentation and restriction is call screening. The CLID number is screened to determine whether a network-provided or user-provided CLID is used to identify the calling party.

CLID blocking can be activated for an entire trunk group. The presentation of a calling party number can be suppressed or overridden for incoming calls on a PRI interface based on the call type.

### **Operation**

The CLID Blocking capability operates when the CLID information is defined and the capability is enabled in table LTDATA. Table LTDATA provides the options for setting up CLID presentation and restriction.

The table flow is different for originating and terminating exchanges. Refer to the following flowchart for the operation flow at the originating exchange. At

### PRI Calling Line Identification Blocking (continued)

the terminating exchange, the calling party number (CGN), presentation indicator (PI), and screening indicator (SI) information elements (IE) are used.

For CLID Blocking per trunk group, table LTCALLS allows the user to block the calls that can be routed over the trunk group. The table is datafilled with the trunk group's LTID, the call type, the initial route for the call, and the subfield LTCOPT to allow the user to determine the blocking required.

#### Operation flow for Calling Line Identification Blocking at the originating exchange

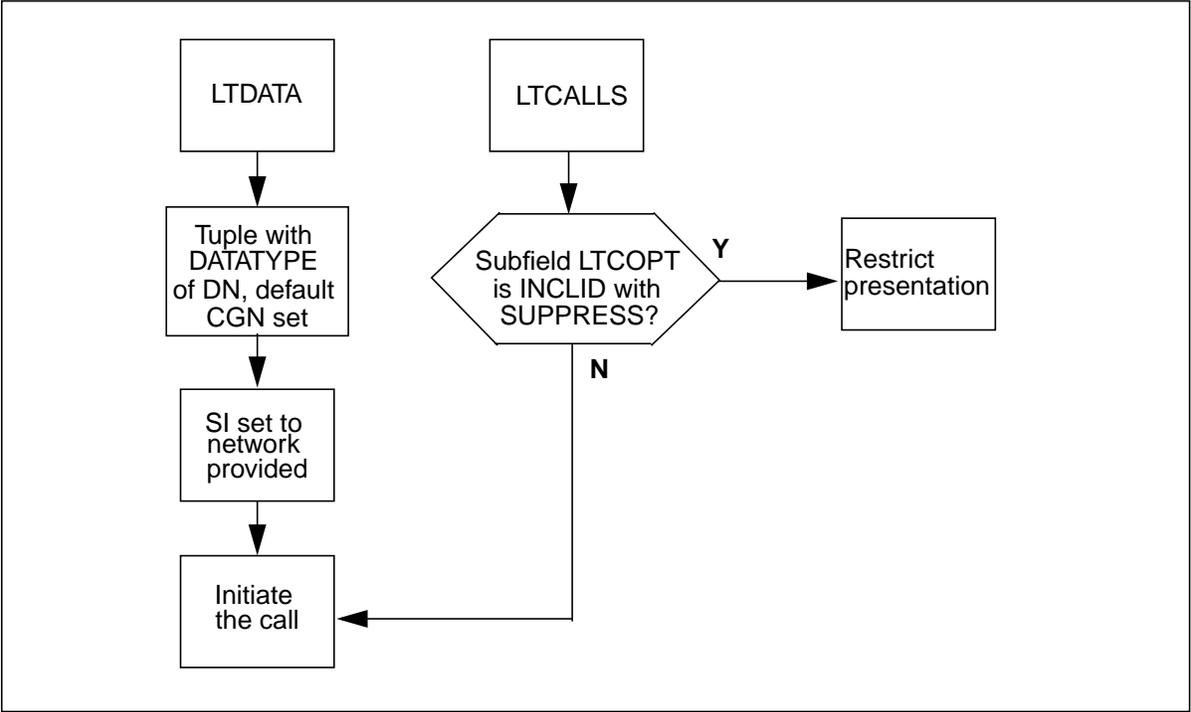

Refer to the following flowchart for the operation flow at the terminating exchange.

## PRI Calling Line Identification Blocking (continued)

### Operating flow for Calling Line Identification Blocking at the terminating exchange

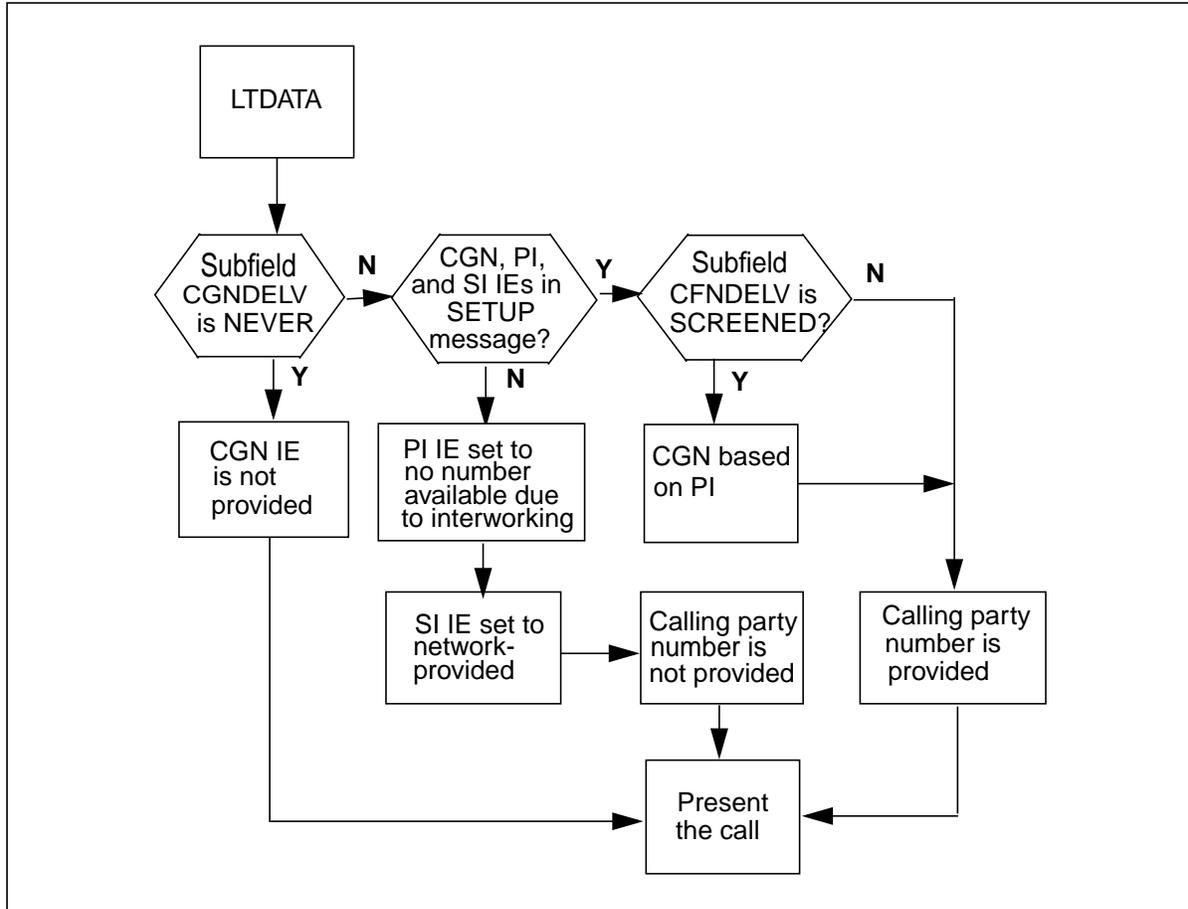

### Translation table flow

Calling Line Identification Blocking does not affect translations.

### Limitations and restrictions

The following limitations and restrictions apply to PRI Calling Line Identification Blocking:

- This capability does not alter the CLID presentation and restriction function currently provided at the far-end exchange.
- The DN option must be datafilled. In table LTDATA, a tuple must be datafilled for each originating PRI interface (one LTID) to provide CLID presentation and restriction.
- For CLID restriction to work correctly on the terminating interface, the SERV tuple in table LTDATA must be datafilled. When not datafilled, the

---

## PRI Calling Line Identification Blocking (continued)

---

subfields CGNDELV and CDNDELV default to ALWAYS, which overrides any other presentation restrictions.

### Interactions

The following paragraphs describe the interaction between PRI Calling Line Identification Blocking and other functionalities.

Integrated services access (ISA) is not required. If ISA is not present, PUB or PVT are the only entries allowed in subfield CALLTYP of table LTCALLS. ISA is functionality code NTX793AA.

### Activation/deactivation by the end user

PRI Calling Line Identification Blocking requires no activation or deactivation by the end user.

### Billing

PRI Calling Line Identification Blocking does not affect billing.

### Station Message Detail recording

The end result of CLID Blocking is a network-provided CGN, which is used in the networked SMDR extension record.

### Datafilling office parameters

PRI Calling Line Identification Blocking does not affect office parameters.

### Datafill sequence

The following table lists the tables that require datafill to implement PRI Calling Line Identification Blocking. The tables are listed in the order in which they are to be datafilled.

#### Datafill tables required for PRI Calling Line Identification Blocking

Table	Purpose of table
LTDATA	Provides the CGN information.
LTCALLS	Provides initial setup for calls routed over the trunk group and CLID suppression.

### Datafilling table LTDATA

The following table shows the datafill specific to PRI Calling Line Identification Blocking for table LTDATA. Only those fields that apply directly

## PRI Calling Line Identification Blocking (continued)

to PRI CLID Blocking are shown. For a description of the other fields, refer to the data schema section of this document.

### Datafilling table LTDATA

Field	Subfield	Entry	Explanation and action
LTDKEY		see subfields	Logical terminal datakey. Datafill subfields LTINDEX (subfields LTGRP and LTNUM) and DATATYPE as one concatenated entry. Separate the three values with blank spaces. You are not prompted for the subfields individually.
	LTINDEX	see subfields	Logical terminal index. This field consists of subfields LTGRP and LTNUM.
	LTGRP	alphanumeric	Logical terminal group. Enter the trunk group name.
	LTNUM	numeric (1 to 1022)	Logical terminal number. Enter a number from 1 to 1022 for the logical terminal number within the group.
	DATATYPE	SERV	Logical terminal data type. Enter SERV for service.
LTDRSLT		see subfields	Logical terminal results. Datafill subfields DATATYPE and CGNDELV.
	DATATYPE	SERV	Data type. Enter SERV for service.
	CGNDELV	SCREENED, ALWAYS, NEVER	<p>Calling party number delivery. Enter one of the following values:</p> <p>Enter SCREENED to send the calling party number based on the PI.</p> <p>Enter ALWAYS to send the calling party number and PI to the far-end exchange. This action is the default if a tuple with a DATATYPE of SERV is not datafilled for the interface.</p> <p>Enter NEVER to never send the calling party number to the far-end exchange under any condition.</p> <p><b>Note:</b> This field can be used to override the PI provided when subfield OPTION is DFLTPI.</p>



---

## PRI Calling Line Identification Blocking (continued)

---

### Datafill example for table LTDATA

The following example shows sample datafill for table LTDATA.

### MAP display example for table LTDATA

LTDKEY	LTDRSLT
ISDN    505    SERV	SERV Y N SCREENED ALWAYS    \$

### Datafilling table LTCALLS

The following table shows the datafill specific to PRI Calling Line Identification Blocking for table LTCALLS. Only those fields that apply directly to PRI CLID Blocking are shown. For a description of the other fields, refer to the data schema section of this document.

#### Datafilling table LTCALLS (Sheet 1 of 3)

Field	Subfield	Entry	Explanation or action
LTID		see subfields	Logical terminal identifier. Datafill subfields LTGNUM (subfields LTGRP and LTNUM) and CALLTYP as one concatenated entry. Separate the three values with blank spaces. You are not prompted for the subfields individually.
	LTGNUM	see subfields	Logical terminal group number. This field consists of subfields LTGRP and LTNUM. This is known as the LTID.
	LTGRP	alphanumeric	Logical terminal group. Enter the trunk group name from table LTDEF.
	LTNUM	numeric	Logical terminal number. Enter the trunk group number from table LTDEF.

## PRI Calling Line Identification Blocking (continued)

### Datafilling table LTCALLS (Sheet 2 of 3)

Field	Subfield	Entry	Explanation or action
	CALLTYP	FX, INWATS, PUB, PVT, TIE, WATS	<p>Call type. For ISA, enter one of the following values:</p> <ul style="list-style-type: none"> <li>• FX for foreign exchange</li> <li>• INWATS for inward wide area telephone service</li> <li>• PUB for public</li> <li>• PVT for private</li> <li>• TIE for tie line</li> <li>• WATS for outward wide area telephone service</li> </ul> <p><b>Note:</b> When ISA is not present, only PUB or PVT are valid call types.</p> <p>When no tuple exists for a specified LTID and CALLTYP, the call is blocked.</p>
OPTIONS		see subfields	Options. This field consists of subfield LTCOPT and refinement CLIDFEAT.
	LTCOPT	INCLID	<p>Line trunk controller routing option. Enter INCLID. Determine the CLID blocking required. Enter \$ to end the tuple.</p> <p><b>Note:</b> INCLID can be specified only once per field LTID and call type (the key).</p>
	CLIDFEAT	NTWKOVRD, SUPPRESS	<p>Calling line identification feature. Enter SUPPRESS to restrict presentation of the incoming calling party number.</p> <p>The following features can be involved in a call over the PRI trunk:</p> <ul style="list-style-type: none"> <li>• Call Forward</li> <li>• Call Park</li> <li>• Call Pickup</li> <li>• Call Transfer</li> <li>• Automatic Call Distribution (ACD)</li> <li>• Network Ring Again</li> </ul>

**PRI Calling Line Identification Blocking** (continued)

Datafilling table LTCALLS (Sheet 3 of 3)

Field	Subfield	Entry	Explanation or action
			<p>Presentation of NAME is not affected. The PI for the calling number is restricted, but the digits are not discarded from the CGN IE.</p> <p>Enter NTKWKOVRD to override the CLID restrictions defined by table CUSTNTWK at the terminating exchange.</p> <p><b>Note 1:</b> SUPPRESS has no affect if the calling number delivery override (CNDBO) feature is activated. CNDBO overrides DN suppression. Subfield CGNDELV in table LTDATA prevents the calling number being sent in the outgoing direction.</p> <p><b>Note 2:</b> NTKWKOVRD only applies when the PRI trunk terminates directly to a line agent with display capabilities. CLID restrictions defined in table CUSTNTWK are overridden. Other DN suppression features and subfield CGNDELV in table LTDATA are not affected. A calling party's DN may not be displayed if it is blocked by subfield CGNDELV. NTKWKOVRD is compatible with CNDBO.</p> <p><b>Note 3:</b> INCLID can be specified only once per field LTID and call type. Thus SUPPRESS and NTKWKOVRD cannot both be present in the same tuple. Both entries are not supported for attendant console interworking and noncall associative features (for example, network executive message waiting).</p>

**Datafill example for table LTCALLS**

The following example shows sample datafill for table LTCALLS

**MAP display example for table LTCALLS**

LTID	XLARTSEL	OPTIONS
ISDN 1008 PVT XLAIBN 0		CUST1 0 3

## **PRI Calling Line Identification Blocking (end)**

---

### **Translation verification tools**

PRI Calling Line Identification Blocking does not use translation verification tools.

### **SERVORD**

PRI Calling Line Identification Blocking does not use SERVORD.

---

## PRI Calling Name Delivery

---

### Ordering codes

Functional group ordering code: NI000030

Functionality ordering code: not applicable

### Release applicability

NA009 and up

### Prerequisites

This document includes all the data table information for this functionality. Complete use of this functionality can require software and hardware not described in this document.

### Description

The ISDN PRI Calling Name (I-CNAM) Delivery feature provides the ISDN PRI called party with the name of the calling party.

The switch retrieves the calling party name from one of the following sources:

- the ISDN user part (ISUP) initial address message (IAM)
- a local lookup table
- a central name database using transaction capabilities application part (TCAP) messaging

This feature only affects the public network and is only supported within the NATIONAL ISDN PRI (NI-PRI) variant. I-CNAM is available to the NA100 market in NA009 and up.

### Operation

ISDN PRI I-CNAM allows the called party to retrieve the calling party name from a central name database using TCAP messaging.

Terminating TCAP queries based on the calling party DN occur for both intra-switch and inter-switch calls. The calling party name is supplied to the customer premises equipment (CPE), provided the presentation status is "allowed" and the calling name is retrieved.

The calling name privacy indicator is disregarded when determining whether to present the calling name to the CPE. The linking of the calling number privacy and the calling name privacy is required by Federal Communications Commission (FCC) regulations. To obtain the calling party name, a 10-digit DN must be known.

## **PRI Calling Name Delivery** (continued)

---

Transporting calling name information for inter-switched calls is dependent on common channel signaling 7 (CCS7) connectivity between the originating and terminating offices. If the calling name text is in the IAM and the office parameter IAM\_USE\_NAME\_CHAARS in table OCFENG is set to Y, it is used.

If in table CUSTNTWK suboption TCAPNM is datafilled with the LOCAL option, the local name lookup feature is active. The switch searches the local DMS database (table DNATTRS) for a name for a specific calling DN. If a local name is not found, a TCAP name query can be sent to obtain the calling name from a central name database.

The central residence name database provides a name of up to 15 characters and a permanent privacy indicator. The information retrieved by the database is passed to the terminating switch in a TCAP response package.

If the name cannot be obtained from the TCAP central residence database and there is no entry for the DN or the TCAP query is lost and a timeout occurs, a "not available" indication is delivered to the called party in a facility information element (IE). The privacy indicator from the central name database is ignored.

### **Translations table flow**

The PRI Calling Name Delivery translations tables are described in the following list.

- **Table LTDATA**– A PRI Calling Name Delivery option is required to enable the feature. Because line options cannot be assigned to trunks, the option must be associated with the logical terminal. Service option TCAP\_CNAM in table LTDATA is associated with the trunk's LTID. This option is checked by a PRI terminating agent to determine whether to deliver the calling party name. If option TCAP\_CNAM appears on the PRI interface, the calling name is delivered.
- **Table OFCENG**– The IAM information element of ISUP contains the generic name (GN) parameter. The GN contains the calling name. The office parameter IAM\_USE\_NAME\_CHARS in table OFCENG controls the use of the GN parameter to obtain the calling name from the IAM.
- **Table TCAPTRID**– This table defines the number of TCAP transaction identifiers (TRID) required by each network application. This table defines the number of IDs to support I-CNAM.
- **Table CUSTNTWK**– The suboption TCAPNM in table CUSTNTWK can be datafilled with LOCAL or NONLOCAL. When set to LOCAL, the TCAPNM local lookup feature is in effect and searches the local DMS database for the calling name, or gets the calling name from the party

---

## PRI Calling Name Delivery (continued)

---

information parameter (PIP) of the ISUP IAM. The NONLOCAL setting turns off the local lookup feature. The default value of suboption TAPNM is NONLOCAL. the LOCAL value must be set to activate the local lookup functionality.

- Table LTCALLS– To set the TCAP timer, a corresponding LTID in table LTCALLS must have the customer group provisioned as in table LTDATA.
- Table CUSTHEAD– The TCAP timer is assigned on a customer group basis. The PRI TCAP\_CNAM option in table LTDATA is assigned for each LTID. A customer group's attributes control the TCAP timer in table CUSTHEAD. The TCAP timer option (NDTIMOUT) ha a range 1 to 6 seconds. The default timer value for the TCAP interface is 3 seconds.

The PRI Calling Name Delivery translation flow is shown in the following flowchart:

**PRI Calling Name Delivery** (continued)

**Table flow for PRI Calling Name Delivery**

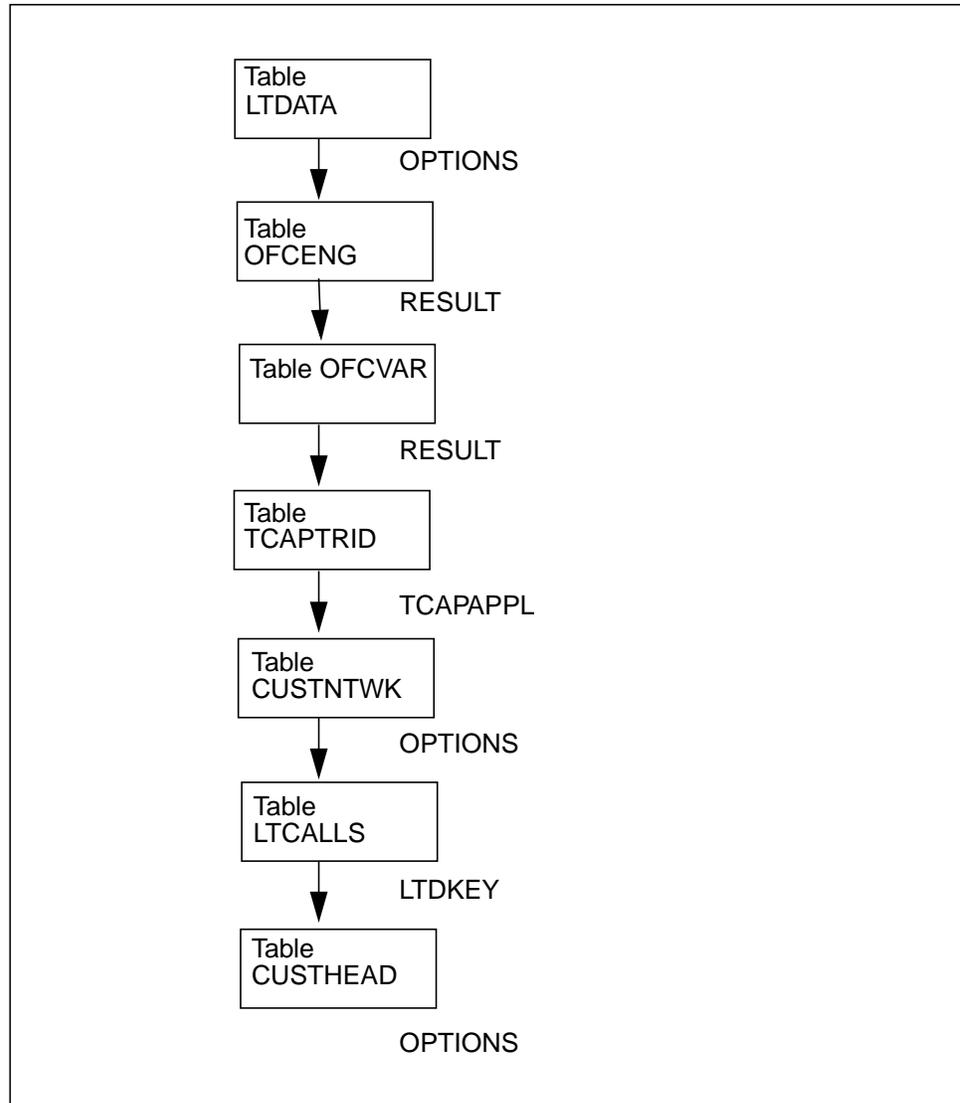

The following table lists the datafill content used in the flowchart.

**Datafill used for the flow chart (Sheet 1 of 2)**

Datafill table	Example of data
LTDATA	ISDN 10 SERV SERV Y Y ALWAYS ALWAYS (TCAPNM) \$
OFCENG	IAM_USE_NAME_CHARS Y
TCAPTRID	CNAM 100 0 N



---

## PRI Calling Name Delivery (continued)

---

### Datafill used for the flow chart (Sheet 2 of 2)

Datafill table	Example of data
CUSTNTWK	PRAEFAULT PUBLIC 0 \$ NONLOCAL
LTCALLS	ISDN 10 PUB XLAIBN 601 PRAEFAULT 0 0 \$
CUSTHEAD	PRAEFAULT PRAXLA NDGT NIL (NDTIMOUT 6)

### Limitations and restrictions

The following limitations and restrictions apply to PRI Calling Name Delivery:

- This feature applies to the NI-PRI variant only.
- FCC regulations require the calling number presentation indication and calling name presentation to be linked. The privacy status is always determined from the calling number privacy indicator.
- The blocking toggle parameter of the calling number privacy indicator is not supported in I-CNAM and is not used.
- End-to-end ISUP SS7 connectivity is required on inter-switched calls to transmit the calling DN to the ISDN PRI terminating DMS-100 switch.
- All necessary datafill for providing the residential and MDC TCAP CNAM (and BRI I-CNAM) functionality are required.
- The central name database requires a 10-digit DN in the TCAP query. Otherwise, an "unavailable" indication is sent to the called party.

### Interactions

In the NA010 release, the PRI SUSP for CNAME feature allows the PRI I-CNAME feature to support interactions with the following:

- advanced intelligent network (AIN) features
- calling number screening and editing features
- redirection (call forwarding) features

### Activation/deactivation by the end user

PRI Calling Name Delivery requires no activation or deactivation by the end user.

### Billing

In the NA010 release, the PRI SUSP for CNAME feature allows the PRI I-CNAM feature to support subscriber usage-sensitive pricing (SUSP) billing.

## PRI Calling Name Delivery (continued)

### Datafilling office parameters

The following table shows the office parameters used by PRI Calling Name Delivery.

#### Office parameters required for PRI Calling Name Delivery

Table name	Parameter name	Explanation and action
OFCENG	IAM_USE_NAME_CHARS	This parameter delivers the functionality of PRI Calling Name Delivery. The IAM information element of ISUP contains the GN parameter. The GN contains the calling name and the presentation indicator. This office parameter controls whether to use the calling name from the IAM.

### Datafilling sequence

The following table lists the tables that require datafill to install PRI Calling Name Delivery. The table are listed in the order in which they are to be datafilled.

#### Datafill tables required for PRI Calling Name Delivery

Table	Purpose of table
OFCENG	Office engineering. This table contains data on engineering parameters for the office.
LTDATA	Logical terminal data. This table stores service-related data associated with an LTID.
CUSTNTWK	Customer group network. This table allows the operating company to specify a network name with which a customer group is associated. It also provides a predetermined global numeric identifier in the specified NETNAME used for the customer group throughout the network.

### Datafilling table LTDATA

The following table shows the datafill specific to PRI Calling Name Delivery for table LTDATA. Only those fields that apply directly to PRI Calling Name Delivery are shown.

#### Datafilling table LTDATA

Field	Subfield	Entry	Explanation and action
	OPTION	TCAP_CNAM	Option. Enter TCAP_CNAM to enable PRI Calling Name Delivery.

---

**PRI Calling Name Delivery** (continued)

---

**Datafill example for table LTDATA**

The following example shows sample datafill for table LTDATA.

**MAP display example for table LTDATA**

LTDKEY		LTDRESULT	
ISDN	10	SERV	
		SERV	Y Y ALWAYS ALWAYS (TCAP_CNAM) \$

**Datafilling table CUSTNTWK**

The following table shows the datafill specific to PRI Calling Name Delivery for table CUSTNTWK. Only those fields that apply directly to PRI Calling Name Delivery are shown.

**Datafill tables required for PRI Calling Name Delivery**

Field	Subfield	Entry	Explanation or action
	TCAPNM	LOCAL, NONLOCAL	Enter LOCAL to activate the TCAPNM local lookup feature and search the local DMS database for the calling name. Enter NONLOCAL to disable the feature and perform only TCAP queries. the default value is NONLOCAL.

**Datafill example for table CUSTNTWK**

The following example shows sample datafill for table CUSTNTWK.

**MAP display example for table CUSTNTWK**

CUSTNAME	NETNAME	NETCGID	DNREVXLA OPTION
RES1	PUBLIC		0 \$ (TCAPNM LOCAL) \$

## **PRI Calling Name Delivery (end)**

---

### **Translation verification tools**

PRI Calling Name Delivery does not use translation verification tools.

### **SERVORD**

PRI Calling Name Delivery does not use SERVORD.

---

## PRI Equal Access

---

### Ordering code

Functionality group ordering code: NI000022

Functionality ordering code: Not applicable

### Release applicability

BCS36 and up

### Prerequisites

To operate, PRI Equal Access has the following prerequisites:

- NI0 ISDN Base, NI000007
- MDC - MDC Minimum, MDC00001

### Description

PRI Equal Access provides basic equal access end office (EAEO) translation capabilities for public calls originating on a PRI trunk. This capability provides transit network selection for public calls.

### Operation

The EAEO translation and carrier screening is allowed per PRI trunk group by datafilling the logical terminal identifier (LTID) of the PRI trunk.

Table LTCALLS provides for the routing of calls over the trunk group. The table is datafilled with the trunk group's LTID, the call type, and the equal access routing options.

### Translation table flow

PRI Equal Access does not affect translations. Refer to the PRI Call Routing capability for TRAVER examples.

### Limitations and restrictions

PRI Equal Access has no limitations or restrictions.

### Interactions

PRI Equal Access has no functionality interactions.

### Activation/deactivation by the end user

PRI Equal Access requires no activation or deactivation by the end user.

## PRI Equal Access (continued)

### Billing

PRI Equal Access does affect billing.

### Station Message Detail Recording

PRI Equal Access does affect Station Message Detail Recording.

### Datafilling office parameters

PRI Equal Access does not affect office parameters.

### Datafill sequence

The following table lists the tables that require datafill to implement PRI Equal Access. The tables are listed in the order in which they are to be datafilled.

#### Datafill tables required for Equal Access

Table	Purpose of table
LTCALLS	Provides the initial translations for calls routed over the trunk group.

### Datafilling table LTCALLS

The following table shows the datafill specific to PRI Equal Access for table LTCALLS. Only those fields that apply directly to PRI Equal Access are shown. For a description of the other fields, refer to the data schema section of this document.

#### Datafilling table LTCALLS (Sheet 1 of 2)

Field	Subfield	Entry	Explanation and action
LTID		see subfields	Logical terminal identifier. Datafill subfields LTGNUM and CALLTYP as one concatenated entry. Separate the three values with blanks. You are not prompted for the subfields individually.
	LTGNUM	see subfields	Logical terminal group number. This is made up of subfields LTGRP and LTNUM.
	LTGRP	alphanumeric	Logical terminal group. Enter the trunk group name from table LTDEF.
	LTNUM	numeric	Logical terminal number. Enter the trunk group number from table LTDEF.
	CALLTYP	PUB	Call Type. Enter PUB for public.

**PRI Equal Access** (continued)**Datafilling table LTCALLS (Sheet 2 of 2)**

Field	Subfield	Entry	Explanation and action
OPTIONS		see subfields	Options
	LTCOPT	EA, LPIC	Line trunk controller routing option. Enter EA for equal access and refinements PIC and CHOICE. Enter LPIC and refinements LCARRIER and LCHOICE or intra-LATA Competition. LPIC allows equal access for all connected intra-LATA calls. Enter a \$ to end the tuple.
	PIC	alphanumeric	Primary Inter-LATA carrier. Enter the other common carrier (OCC) name.  <b>Note:</b> The carrier must be specified in table OCCNAME first.
	CHOICE	Y, N	Choice. Use an equal access plan (EAP) prefix to identify an alternate OCC. Enter Y to use the EAP prefix. Enter N to not use the EAP prefix.
	LCARRIER	alphanumeric carrier name	Primary intra-LATA carrier name. Enter the prescribed carrier name. The carrier name must be datafilled in table OCCNAME and OCCINFO.
	LCHOICE	Y, N	Intra-LATA choice. Enter Y to indicate the prescribed carrier can be overridden by the specified carrier. Otherwise, enter N.

**Datafill example for table LTCALLS**

The following example shows sample datafill for table LTCALLS.

**MAP display example for table LTCALLS**

LTID	XLARTSEL	OPTIONS
ISDN 1008 PUB XLAIBN 0 CUST1 0 3		( EA MCI N )\$

**Translation verification tools**

PRI Equal Access does affect call routing translations. Refer to PRI Call Routing capability for TRAVER examples using Equal Access.

**PRI Equal Access** (end)

---

**SERVORD**

PRI Equal Access does not use SERVORD.



---

## PRI Flexible Timers

---

### Ordering code

Functionality group ordering code: NI000022

Functionality ordering code: not applicable

### Release applicability

BCS36 and up

### Prerequisites

To operate, the PRI Flexible Timers capability has the following prerequisites:

- NI0 ISDN Base, NI000007
- MDC - MDC Minimum, MDC00001

### Description

This capability provides a mechanism for controlling ISDN PRI timers through a datafillable table. This independent control of the Q.931 layer 3 timers allows customization for individual networks.

### Operation

The capability operates by defining the protocol variants, timers, and timer values in the ISDN protocol (ISDNPROT) table. The timer values are initially set with default values. Timer values can be changed at any time as the D-channel does not have to be in a specific state.

### Translation table flow

The PRI Flexible Timers capability does not affect translations.

### Limitations and restrictions

The following limitations and restrictions apply to the PRI Flexible Timers capability:

- New values do not affect timers that are already running. New values take effect only on timers started after a datafill change is made.
- Range checking is done by the DMS-core during table control.

### Interactions

The PRI Flexible Timers capability has no functionality interactions.

## **PRI Flexible Timers** (continued)

---

### **Activation/deactivation by the end user**

The PRI Flexible Timers capability requires no activation or deactivation by the end user.

### **Billing**

The PRI Flexible Timers capability does not affect billing.

### **Station Message Detail Recording**

The PRI Flexible Timers capability does not affect Station Message Detail Recording.

### **Datafilling office parameters**

The PRI Flexible Timers capability does not affect office parameters.

### **Datafill sequence**

The following table lists the tables that require datafill to implement the PRI Flexible Timers capability. The tables are listed in the order in which they are to be datafilled.

#### **Datafill tables required for PRI calling Line Identification Blocking**

<b>Table</b>	<b>Purpose of table</b>
ISDNPROT	To define values for the PRI timers.

## PRI Flexible Timers (continued)

### Datafilling table ISDNPROT

The following table shows the datafill specific to PRI Flexible Timers for table ISDNPROT. Only those fields that apply directly to PRI Flexible Timers are shown. For a description of the other fields, refer to the data schema section of this document.

#### Datafilling table ISDNPROT (Sheet 1 of 2)

Field	Subfield	Entry	Explanation and action
PROTVAR		NTNAPRI, U449PRI, U459PRI, NIPRI	Protocol variant. Enter NTNAPRI, U449PRI, or U459PRI or NIPRI.  <b>Note:</b> Use NTNAPRI when connecting switching nodes manufactured by Northern Telecom.
PVCAPPL		USRTIMER, NETTIMER	Protocol variant application. Enter USRTIMER for user-side timers. Enter NETTIMER for network-side timers.
APPLDATA		see subfields	Application data
	LOG_DATA_FORMAT_TYPE	PRITIMER	Log data format type. Enter PRITIMER for PRI timers.
	TMR_OPT	see subfields	Timer option. Datafill subfields TIMER_NAME and TIMER_VALUE as one concatenated entry. Separate the two values with a blank. You are not prompted for the subfields individually. Enter a \$ to end the tuple.
	TIMER_NAME	T301, T302, T303, T304, T305, T306, T308, T309, T310, T313, T314, T316, T317, T321, T322, T323	Timer name. Enter timer name, for example, T301.

## PRI Flexible Timers (continued)

### Datafilling table ISDNPROT (Sheet 2 of 2)

Field	Subfield	Entry	Explanation and action
	TIMER_VALUE	numeric (0 to 1023)	<p>Timer value. Enter a number from 0 to 1023 for the timer interval. Zero (0) resets the timer to the default. Initially the timers are loaded with default values.</p> <p>The following are the NTNAPRI protocol variant timer names, ranges of acceptable timer values in seconds, and default values:</p> <ul style="list-style-type: none"> <li>• T301-alerting message, 1 to 1023, 180</li> <li>• T303-setup response, 1 to 30, 4</li> <li>• T305-disconnect response, 1 to 80, 30</li> <li>• T308-release response, 1 to 10, 4</li> <li>• T309-data link establishment, 1 to 120, 30</li> <li>• T310-posting dialing, 1 to 200, 10</li> <li>• T313-connect response, 1 to 30, 4</li> <li>• T316-restart acknowledge, 1 to 200, 30</li> <li>• T321-backup D-channel failure, 1 to 80, 40</li> <li>• T322-status, 1 to 30, 4</li> <li>• T323 B-channel service messaging</li> </ul> <p><b>Note:</b> T313 is only a user-side timer. Other timer numbers (T302 interdigit, T304 overlap sending, T306 disconnect response, T314 message segments, and T317 restart) can be accessed but they are not used at this time and have no effect on the DMS-100 switch.</p>

### Datafill example for table ISDNPROT

The following example shows sample datafill for the PRI Flexible Timers capability in table ISDNPROT.

---

**PRI Flexible Timers (end)**

---

**MAP display example for table ISDNPROT**

PROTVAR	PVCAPPL	APPLDATA
NTNAPRI	USRTIMER	PRITIMER (T301 150)(T322 1)\$

**Error messages for table ISDNPROT**

The following error messages apply to table ISDNPROT.

**Error messages for table ISDNPROT**

Error message	Explanation and action
INVALID TIMER VALUE: TIMER T3XX MUST BE LESS THAN OR EQUAL TO XXX SEC	An entered timer value is greater than that allowed. Reenter a value less than or equal to the number specified in the error message.

**Translation verification tools**

The PRI Flexible Timers capability does not use translation verification tools.

**SERVORD**

The PRI Flexible Timers capability does not use SERVORD.

## **PRI Hotel/Motel SCOCS**

---

### **Ordering codes**

Functional group ordering code: NI00032

Functionality ordering code: Not applicable

### **Release applicability**

NA009 and up

PRI Hotel/Motel/SCOCS was introduced in NA009 and applies to NI-2.

### **Prerequisites**

PRI Hotel/Motel/SCOCS has no prerequisites.

### **Description**

The primary Rate Interface Hotel/Motel Selective Class-of-Call Screening feature is for originating-only services. This feature provides calls, normally through a PBX, with specified services on a call-by-call (CBC) basis over a single PRI. These services can be received without the need for a dedicated bearer channel for each service.

The Call-by-Call Hotel/Motel (HM) service allows the customer premises equipment (CPE) to request, on an individual basis, that the DMS switch treat a call as an HM call. The HM class of service provides hotels and motels with detailed billing information after the call completes.

The Call-by-Call SCOCS service allows the CPE to request, on an individual call basis, that the DMS switch treat a call as an SCOCS call. SCOCS provides hotels, motels, dormitories, prisons, hospitals, and other institutions with detailed billing information after the call completes.

### **Operation**

To use this feature, a caller located at a hotel, motel, or institution, goes off-hook and dials 0+ the called number. The CPE sends a setup message that designates the requested service. The DMS switch interprets the setup message and routes the call to an operator services system (OSS). The operator at the OSS prompts the caller for the required information, for example, hotel room number, and enters the information at the operator's position. The operator completes the call.

At the completion of the call, the OSS provides the billing information to the automatic message accounting (AMA) system. The OSS also sends the billing information to a billing system that forwards it to the originating hotel or motel.

---

**PRI Hotel/Motel SCOCS** (continued)

---

for HM service, or the appropriate hotel, motel, or institution for SCOCS service.

**Translations table flow**

The PRI Hotel/Motel/SCOCS translations tables are described in the following list:

- LTDEF
- LTCALLS
- SIDXLA

The PRI Hotel/Motel/SCOCS translation process is shown in the flowchart that follows.

**PRI Hotel/Motel SCOCS** (continued)

**Table flow for PRI Hotel/Motel/SCOCS**

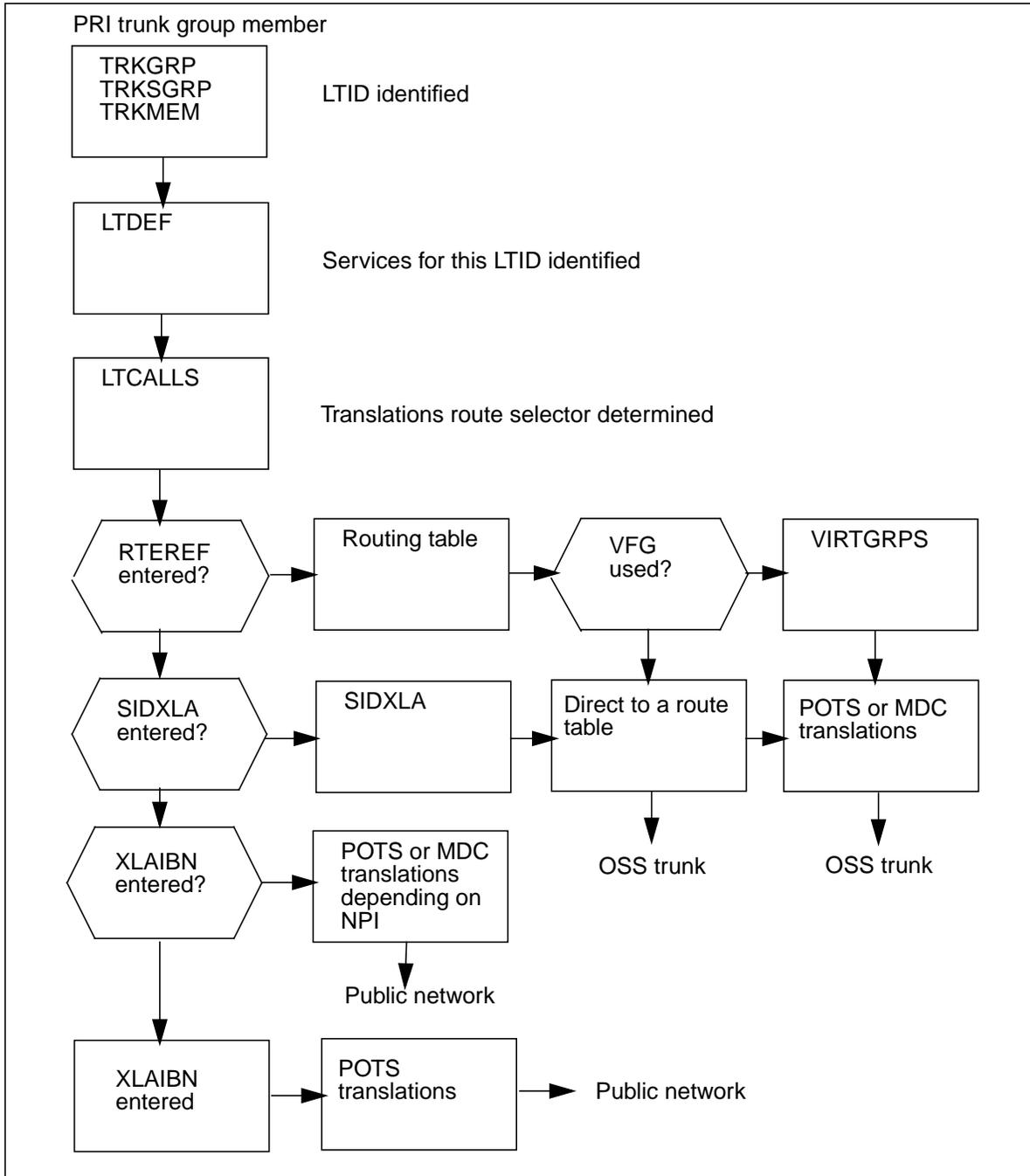



---

## PRI Hotel/Motel SCOCS (continued)

---

The following table lists the datafill content used in the flowchart.

**Table datafill examples for PRI Hotel/Motel SCOCS**

Table	Example data
TRKGRP	SLINTPRI PRA 0 NPDGP NCIT ASEQ N (ISDN 1008) \$
LTDEF	ISDN 50 2B BRAFS (NOPMD) (PVC FUNCTIONAL 2) (DTEI) (SPIDSFY 00) (EKTS) \$
LTCALLS	ISDN 1 SCOCS XLAIBN 1 BNR_SCOCS 0 0 (SIDXLA SCOCS Y Y N) \$
ISAXLA	SCOCS 1 1 (IBNRTE 702) \$
VIRTGRPS	Hotel16 size 2 IBN N BNR 0 0 0 N N N \$

### Limitations and restrictions

The following limitations and restrictions apply to PRI Hotel/Motel/SCOCS:

- VFGs do not support overflow. But, you can establish overflow for call-by-call through the DMS routing tables.
- You cannot associate VFGs with bearer capabilities for a specific PRI.
- Service identifiers for SCOCS services have a range of 0–1023.
- The DMS switch does not evaluate carrier access code (CAC) digits, in accordance with TR-NWT-001379, called party number (CdPN) information element (IE).

### Interactions

The following paragraph describes the interactions between PRI Hotel/Motel/SCOCS and other functionalities.

#### Advanced Intelligent Network

The CBC services select a B-channel without a determination of whether the DMS switch uses the B-channel for Advanced Intelligent Network (AIN) triggering. The CPE must be able to make this determination to avoid the use of AIN B-channels for non-AIN outgoing calls.

### Activation/deactivation by the end user

PRI Hotel/Motel/SCOCS requires no activation or deactivation by the end user.

### Billing

PRI Hotel/Motel/SCOCS does not affect billing.

## PRI Hotel/Motel SCOCS (continued)

### Station Message Detail Recording

PRI Hotel/Motel/SCOCS does not affect Station Message Detail Recording

### Datafilling office parameters

PRI Hotel/Motel/SCOCS does not affect office parameters.

### Datafill sequence

The following table lists the tables that require datafill to implement PRI Hotel/Motel/SCOCS. the tables are listed in the order in which they are to be datafilled.

#### Datafill tables required for PRI Hotel/Motel/SCOCS

Table	Purpose of table
TRKGRP	Table TRKGRP contains operating company-defined data associated with each trunk group that exists in the switching unit.
LTDEF	Table LTDEF defines the service profile of an ISDN logical terminal (LTID).
LTCALLS	Table LTCALLS sets the call route based on CBC service type and numbering plan.
ISAXLA	Table ISAXLA defines the service identifier data associated with SCOCS calls that use the service identifier to translate and route the calls.
VIRTGRPS	The DMS switch uses table VIRTGRPS to simulate finite resources (lines or trunks) in software.

### Datafilling table TRKGRP

The following table shows the datafill specific to PRI Hotel/Motel/SCOCS for table TRKGRP. Only those fields that apply directly to PRI Hotel/Motel/SCOCS are shown.

#### Datafilling table TRKGRP (Sheet 1 of 2)

Field	Subfield	Entry	
GRPKEY		see subfield	Group key. Subfield CLLI makes up this field.
	CLLI	alphanumeric (1–16 characters)	Common language location identifier. Enter the CLLI code assigned to the PRI trunk group in table CLLI.



## PRI Hotel/Motel SCOCS (continued)

### Datafilling table LTDEF

The following table shows the datafill specific to PRI Hotel/Motel/SCOCS for table LTDEF. Only those fields that apply directly to PRI Hotel/Motel/SCOCS are shown

#### Description of table LTDEF (Sheet 1 of 3)

Field name	Subfield	Entry	Description
LTKEY		see subfields	Logical terminal key - This field consists of two subfields: logical terminal group (LTGRP) and logical terminal number (LTNUM).
	LTGRP	alphanumeric (up to 8 characters)	Logical terminal group. Enter the name of a group of logical terminals. Table LTGRP lists the valid group names in field GROUP.
	LTNUM	1–1022	Logical terminal number. Enter a logical terminal number to identify the logical terminal within the group.
LTAP		B, BD, D, PB, 2B, 2BD	<p>Logical terminal access privilege. Enter one of the following:</p> <ul style="list-style-type: none"> <li>• B for circuit-switching terminals</li> <li>• BD for combined circuit-switching terminals</li> <li>• D for channel-switching or D-channel packet-switching terminals</li> <li>• PB for channel packet-switching terminals</li> <li>• 2B for two B-channel circuit switching</li> <li>• 2BD for D-channel packet switching and circuit switching on the same NI-2 terminal. A terminal with the 2BD option must also have CLASSRE subfield LTCLASS = BRAFS, BRAFS subfield OPTION = PVC, DTEI, AND PVC refinements VERSION = FUNCTIONAL and ISSUE = 2. The NITYPE option must be specified with the value of NI2.</li> </ul> <p><b>Note 1:</b> If the PVC option is not specified, it is added by default as PVC FUNCTIONAL 2.</p> <p><b>Note 2:</b> You cannot change an existing access privilege to 2BD.</p>

**PRI Hotel/Motel SCOCS** (continued)**Description of table LTDEF (Sheet 2 of 3)**

Field name	Subfield	Entry	Description
CLASSREF		see subfields	Class reference. Subfield makes up this field.
	LTCLASS	PRA	Logical terminal class. Enter PRA.
	NUMBCHNL	1–479	Number of B-channels. Enter the maximum number of B-channels that this logical terminal is allowed to use at any time. This number is the number of B-channels on the interface datafilled in table TRKMEM.
	NUMCALLS	1–479	Number of calls. Enter the maximum number of calls that are allowed on this logical interface at any one time. NUMCALLS = NUMBCHNL
	INCCALLS	0–479	Incoming calls. this field is not currently used. To satisfy datafill, see the note in field OUTCALLS.
	OUTCALLS	0–479	Outgoing calls. The INCCALLS and OUTCALLS fields are not currently used. INCCALLS + OUTCALLS = NUMCALLS. To satisfy datafill, see the following note.
			<b>Note:</b> To satisfy the editor function, Nortel recommends dividing the number of B-channels by 2 and entering the resulting number in fields INCCALLS and OUTCALLS.
	VARISSUE	see subfields.	Variant issue. This field selects the protocol variant and issue. Subfields VARIANT and ISSUE make up this field.
	VARIANT	NTNAPRI, NIPRI	Protocol variant. Enter one of the following: <ul style="list-style-type: none"> <li>• NTNAPRI</li> <li>• NIPRI</li> </ul>
	ISSUE	NI2V1, V1	Protocol issue. Enter one of the following: <ul style="list-style-type: none"> <li>• NI2V1 for NIPRI</li> <li>• V1 for NTNAPRI</li> </ul>

## PRI Hotel/Motel SCOCS (continued)

### Description of table LTDEF (Sheet 3 of 3)

Field name	Subfield	Entry	Description
	PROFNAME	alphanumeric (up to 8 characters), NIL	<p>Profile name for table PRIPROF. Enter NIL</p> <p>Enter a profile name linking a profile (set of function switches) to an interface. you must first datafill this name in table PRIPROF.</p> <p>The default for this field is NIL which disables all available function switches.</p> <p><b>Note:</b> Field PROFNAME indexes table PRIPROF and is used only when using the NTNAPRI Protocol with a Nortel Meridian 1 or SL-1 PBX. This table sets the function switches and is hard coded. You do not need to add, change, or delete anything from this table.</p>
OPTION		NOCMD, NOPMD, NOVBD, NOVOICE. PGRPID	<p>OPTION - Enter any of the following options: NOCMD to indicate that circuit mode data calls are not allowed, NOPMD to indicate that packet mode data calls are not allowed, NOVBD to indicate that voice band calls are not allowed (3.1 kHz data bearer capability), and NOVOICE to indicate that voice calls are not allowed (speech bearer capability).</p> <p>Enter PGRPID followed by the name of the serving PRI group, to indicate a serving PRI group. This name is the key to table SVPRIGRP, and must be datafiled in table SVPRIGRP. The default for this field is NIL. If the value is NIL, PGRPID does not appear in the options list for the tuple.</p>

### Datafill example for table LTDEF

The following example shows sample data for table LTDEF.

**PRI Hotel/Motel SCOCS** (continued)**MAP display example for table LTDEF**

LTKEY	LTAP	CLASSREF
ISDN 50	2B	
BRAFS (NOPMD) (PVC FUNCTIONAL 2) (DTEI) (SPIDSFX 00) (EKTS) \$		
ISDN 800	2B	
BRAFS (NITYPE NI2) (PVC FUNCTIONAL 2) (DTEI) (SPIDSFX) 01 (EKTS) (CACH) \$		
ISDN 810	2B	
BRAFS (NITYPE NI2) (PVC FUNCTIONAL 2) (DEFLTERM) (TERML 4) \$		

**Datafilling table LTCALLS**

The following table shows the datafill specific to PRI Hotel/Motel/SCOCS for table LTCALLS. Only those fields that apply directly to PRI Hotel/Motel/SCOCS are shown.

**Description of table LTCALLS (Sheet 1 of 3)**

Field	Subfield	Entry	Description
LTID		see subfields	Logical terminal identifier. This field consists of subfields LTGRP[, LTNUM, and CALLTYPE.
	LTGRP	alphanumeric (up to 8 characters)	Logical terminal group. Enter the logical terminal group name.
	LTNUM	1-1022	Logical terminal number. Enter the logical terminal number within the group.

## PRI Hotel/Motel SCOCS (continued)

### Description of table LTCALLS (Sheet 2 of 3)

Field	Subfield	Entry	Description
	Call type	HM, SCOCS	<p>Call type. Enter the call type associated with the LTID. The DMS switch can associate more than one type with the same identifier. Select from the following list of call types.</p> <ul style="list-style-type: none"> <li>• HM (hotel/motel) provides for hotel/motel services.</li> <li>• SCOCS is an originating-only service that allows you to associate several distinct classes of service with a single PRI.</li> </ul>
XLARTE	XLARTE	RTEREF, IBNRTE, XLAIBN, XLALEC	<p>Translations route. Enter one of the following translations routes.</p> <ul style="list-style-type: none"> <li>• RTEREF if translation is done by a specific table and index, such as OFRT, IBNRTE, and other routing tables</li> <li>• IBNRTE to indicate IBN route</li> <li>• XLAIBN for integrated business network (IBN) translations. This selection is used only in PBX or centrex offices.</li> <li>• XLALEC for local exchange carrier translations, such as plain old telephone service (POTS), or in PBX or centrex type offices. If the</li> </ul>



**PRI Hotel/Motel SCOCS** (continued)**Description of table LTCALLS (Sheet 3 of 3)**

Field	Subfield	Entry	Description
	OPTIONS	see subfield	Option. This field consists of subfield LTCOPT.
	LTCOPT	EA, INCLID, LPIC, SIDXLA	<p>Logical terminal option. Enter EA to allow equal access for all connected inter-LATA and international carriers, and datafill refinements PIC and CHOICE. EA is valid if the entry in field CALLTYP is PUB.</p> <p>Enter INCLID to allow ISDN PRI Calling Name Delivery (CND) screening capabilities.</p> <p>Enter LPIC, and datafill refinements LCARRIER and LCHOICE, to implement the enhancements intra-LATA Competition. LTCOPT = LPIC allows equal access for all connected intra-LATA calls. LPIC is valid if the entry in field CALLTYP is PUB and the entry in field XLARTE is XLALEC or XLAIBN.</p> <p>Enter SIDXLA to allow SID routing on a specific PRI ISA call type.</p>

**Datafill example for table LTCALLS**

The following example shows sample datafill for table LTCALLS.

## PRI Hotel/Motel SCOCS (continued)

### MAP display example for table LTCALLS

LTID	XLARTSEL	OPTIONS
ISDN 556 HM	XLAI BN	600 COMKODAK 0 0 \$
ISDN 557 SCOCS	XLAI BN	600 COMKODAK 0 0 (SIDXLA SCOCS Y Y N ) \$
ISDN 558 PUB	XLAI BN	600 COMKODAK 0 0 \$
ISDN 559 PUB	XLAL EC	1 \$
ISDN 18 PUB	XLAI BN	42 (EA CAR1 Y) (LPIC CAR1 Y) \$
ISDN 11 PUB	XLAI BN	49 (EA CAR1 Y) (LPIC CAR2 Y) \$

### Datafilling table ISAXLA

The following table shows the datafill specific to PRI Hotel/Motel/SCOCS for table ISAXLA. Only those fields that apply directly to PRI Hotel/Motel/SCOCS are shown

#### Field descriptions of table ISAXLA (Sheet 1 of 2)

Field	Subfield	Entry	Explanation and action
IRTRNAME		alphanumeric (up to 128 8-character names)	Router name. Enter up to 128 router names datafilled in table LTCALLS under the XLAISA selector, or in field IRTRNAME in table MBGXLA. The DMS switch allows multiple tuples with the same router name.
SIDFROM		0–1023	Service identifier from. Enter the lower boundary of the SID values that continue translations and routing.

---

**PRI Hotel/Motel SCOCS** (continued)

---

**Field descriptions of table ISAXLA (Sheet 2 of 2)**

Field	Subfield	Entry	Explanation and action
SIDTO		0–1023	<p>Service identifiers to. Enter the upper boundary of the SID values that continue translations and routing.</p> <p><b>Note 1:</b> The SIDFROM and SIDTO values from a range of values that can be datafilled over the entire range of the SIDs, over a subrange of the SIDs, or over a single SID.</p> <p><b>Note 2:</b> The SIDFROM and SIDTO values cannot overlap each other for the same router name</p> <p><b>Note 3:</b> .A maximum of 128 different SIDFROM and SIDTO combinations can be specified for the same router name.</p>
RTEID		see subfield	Router identifier. This field is made up of subfield TABNAME. This is an optional table route reference.
	TABNAME	IBNRT2, IBNRT3, IBNRT4, IBNRTE, OFR2, OFR3, OFR4, OFRT, ITOPS	Table name. Enter the routing table name. If no route identifier is used, enter \$.
INDEX		0–1023 or alphanumeric	Index. Enter the index into the routing table.

**Datafill example of table ISAXLA**

The following example shows sample datafill for table ISAXLA.

**PRI Hotel/Motel SCOCS** (continued)

**MAP display example for table ISAXLA**

IRTRNAME	SIDFROM	SIDTO	RTEID
HM	1	1	(IBNRTE 702)

**Datafilling table VIRTGRPS**

The following table shows the datafill specific to PRI Hotel/Motel/SCOCS for table VIRTGRPS. Only those fields that apply directly to PRI Hotel/Motel/SCOCS are shown

**Field descriptions of table VIRTGRPS (Sheet 1 of 3)**

Field	Subfield	Entry	Explanation and action
KEY		see subfield	Virtual facility group (VFG) key. This field is the key to table VIRTGRPS and is made up of subfield VIRTGRP.
	VIRTGRP	alphanumeric (1–6 characters) or blank	Virtual facility group. If the entry is the first entry for the VFG, enter a user-defined name. The addition of a tuple defines the name that is used in other tables that need VFGs.  If the entry is not the first entry for the VFG, leave the field blank.
DATA		see subfields	Virtual facility group data. This field is made up of subfields MEMBERS and INCTYPE.
	MEMBERS	see subfields	Virtual facility group members. This subfield is made up of refinement VFGTYPE and subfields USESGRP and SIZE.
	VFGTYPE	SIZE, uses	Virtual facility group type. If this is the first entry for the VFG, enter SIZE. If this is not the first entry, enter USES.
	SIZE	0–2048	Size. Datafill this refinement if the value of subfield VFGTYPE is SIZE. Enter the number of simultaneous accesses allowed for the VFG.

**PRI Hotel/Motel SCOCS** (continued)**Field descriptions of table VIRTGRPS (Sheet 2 of 3)**

Field	Subfield	Entry	Explanation and action
	USESGRP	alphanumeric or NIL	<p>Virtual facility group name. Datafill this refinement if the value of VFGTYPE is USES. The VFG name is the name of the VFG specified in table VIRTGRPS.</p> <p>This entry provides the means to have virtual two-way trunks or to associate more than one set of screening data with the same set of virtual circuits, or both.</p> <p>If the entry is not the first for the VFG, enter NILVFG.</p>
	INCTYPE	IBN, POTS	<p>Incoming type. If this is the first entry for the VFG, do one of the following steps:</p> <p>Enter IBN if the call is entering the Integrated Business Network (IBN) translation environment.</p> <p>Enter POTS if the call is entering the POTS translation environment.</p>
	BILLNUM	numeric (vector of up to 11 digits) or NIL	<p>Billing number. Enter the billing number to which the DMS switch charges for the next leg of the call.</p> <p>If the call is charged to the originator's billing number for the next leg of the call, enter N.</p>
	LINEATTR	0-4095	<p>Line attribute index. Enter the line attribute index that specifies the translations and screening tables used for the next leg of the call.</p>
	LINECDR	Y, NO	<p>Line call detail recording. Enter Y (yes) if CDR is required to record virtual line type calls. Enter N (no) if CDR is not required.</p>

**PRI Hotel/Motel SCOCS** (continued)

**Field descriptions of table VIRTGRPS (Sheet 3 of 3)**

Field	Subfield	Entry	Explanation and action
OPTIONS		see subfield	Options. Subfield OPTION makes up this field. Subfield OPTION is a vector of up to 11 multiples.
	OPTION	CUSTGRP, EA, ENTRYID, IBNPIC, INTPIC, LPIC, RC, TBO, TOLLRST, VFGALSC, VFGAMA, VFGALSC	Option. Enter the list of options assigned to the VFG. Each option and its refinement must be separated by a space. Use as many records as required to datafill the list of options and associated refinements.  If an option is not provided, the subfield requires no datafill.

**Datafill example of table VIRTGRPS**

The following example shows sample datafill for table VIRTGRPS.

**MAP display example for table VIRTGRPS**

KEY	DATA	OPTIONS
Hotel6	SIZE 2 IBN N BNR 0 0 0 N N N \$	

**Translation verification tools**

The following examples show the output from TRAVER when it is used to verify PRI Hotel/Motel/SCOCS.

## PRI Hotel/Motel SCOCS (continued)

## TRAVER output example for PRI Hotel/Motel/SCOCS–hotel/motel example

```

>traver tr wits3nilt1 n cdn 7222001 hm b
TABLE TRKGRP
WITS3NILT1 PRA 0 PRAC NCRT ASEQ N (ISDN 100) $ $
TABLE LTCALLS
ISDN 100 HM XLAIBN 0 THE_FAR_SIDE 0 25 $
TABLE CUSTSTN
TUPLE NOT FOUND
TABLE OFCVAR
AIN_OFFICE_TRIGGRP NIL
TABLE LINEATTR
0 1FR NONE NT FR01 0 613 P622 NLCA TSPS 10 NIL NILSFC
LATA1 0 NIL NIL 00 Y THE_FAR_SIDE 0 0 (HOT) $
LCABILL OFF - BILLING DONE ON BASIS OF CALLTYPE
TABLE STDPRTCT
P622 (1) (65021) 3
. SUBTABLE STDPRT
WARNING: CHANGES IN TABLE STDPRT MAY ALTER OFFICE
BILLING. CALL TYPE DEFAULT IS NP. PLEASE REFER TO
DOCUMENTATION
. 7 810 N NP 0 NA
. SUBTABLE AMAPRT
. KEY NOT FOUND
. DEFAULT VALUE IS: NONE OVRNONE N
TABLE HPCPATTN
TUPLE NOT FOUND
TABLE HNPACONT
613 Y 755 1 (38) (1) (84) (0) 3 $
. SUBTABLE HNPACODE
. 722 722 DN 613 722
AIN Info Collected TDP: no subscribed trigger.
TABLE FNPA7DIG
EMPTY TABLE: TUPLE NOT FOUND
AIN Info Analyzed TDP: no subscribed trigger.
TABLE TOFCNAME
613 722 $
TABLE DNINV
613 722 2001 L HOST 00 0 01 06
AIN Term Attempt TDP: no subscribed trigger.
TABLE DNFEAT
TUPLE NOT FOUND
TABLE DNATTRS
TUPLE NOT FOUND
TABLE DNGRPS
TUPLE NOT FOUND
LNP00100 SOC Option is idle.
LNP Info: Called DN is resident.
LNP Info: Called DN has native NPANXX
LNP Info: HNPA results are used.
TABLE CLSVSCRC

***TRAVER: SUCCESSFUL CALL TRACE***
DIGIT TRANSLATION ROUTES
1 LINE 61137222001
TREATMENT ROUTES. TREATMENT IS: GNCT
1 T120
***TRAVER: SUCCESSFUL CALL TRACE***

```

## PRI Hotel/Motel SCOCS (end)

---

The following is a TRAVER example of SCOCS.

### TRAVER output example for PRI Hotel/Motel/SCOCS–SCOCS example

```
>traver r wits3niltl n cdn pvt 4444 scocs 1 b
TABLE TRKGRP
WITS3NILTL PRA 0 PRAC NCRT ASEQ N (ISDN 100) $ 4
TABLE LTCALLS
ISDN 100 SCOCS XLAIBN 0 THE_FAR_SIDE 0 25 (SIDXLA SCOCS1 N Y N) $
TABLE CUSTSTN
TUPLE NOT FOUND
TABLE OFCVAR
AIN_OFFICE_TRIGGRP NIL
TABLE ISAXLA
SCOCS1 0 100 (IBNRTE 333) $
TABLE IBNRE
  333 N N N N N WITS3NILTL 0
EXIT TABLE IBNRTE

888TRAVER:  SUCCESSFUL CALL TRACE888

IGIT TRANSLATION ROUTES
1 WITS3NILTL  N CDN E164 L 444 NIL_NSF BC 3.1_KHZ_AUD
TREATMENT ROUTES.  TREATMENT IS:  GNCT T120

***TRAVER:  SUCCESSFUL CALL TRACE***
```

## SERVORD

PRI Hotel/Motel/SCOCS does not use SERVORD.



---

## PRI ISDN Treatments

---

### Functionality code

Functionality group ordering code: NI000022

Functionality ordering code: Not applicable

### Release applicability

BCS36 and up

### Prerequisites

To operate, PRI ISDN Treatments has the following prerequisites:

- NI0 ISDN Base, NI000007
- MDC - MDC Minimum, MDC00001

### Description

The ISDN Treatments capability is made up of the audible treatment function. Audible treatment supplies inband tones and announcements for intercept treatments per logical terminal identifier (LTID). With audible treatment, when a speech or a 3.1-kHz audio call is terminated to intercept treatment, the originating exchange returns a PROGRESS message to the terminating exchange and provides inband treatment. Without audible treatment, a DISCONNECT message, with cause, is returned and the call is terminated.

The PROGRESS message contains progress indicator number 8 and either cause value 1 (unallocated/unassigned number) or cause value 27 (destination out of order). The DISCONNECT message contains a variable cause value.

The AUDTRMT (audible treatment) flag, found under the SERV (service) refinement in table LTDATA, is used to optionally provide the ISDN Treatments capability on a per interface basis. If AUDTRMT is set to 'N' (for NO), call clearings are handled as normal. This is the default action. Setting AUDTRMT to 'Y' (for YES) enables inband treatment procedures for *originating* PRI calls with a bearer capability (BC) of speech or 3.1-kHz audio for the following scenarios:

- The call attempt results in a DMS treatment of VACT (vacant code), UNDN (unassigned number), BLDN (blank directory number), or PODN (ported out directory number). (Normally, a DISConnect or RELease COMplete message containing cause #1, "unallocated (unassigned) number", would be sent to the calling interface.)
- The terminating interface receives a call clearing message containing cause #1, "unallocated (unassigned) number".

## **PRI ISDN Treatments (continued)**

---

- The call attempt results in a DMS treatment of TRBL (trouble intercept), TESS (terminating service suspended), or DNTR (deny termination). (Normally, a DISConnect or RELease COMplete message containing cause #27, “destination out of order”, would be sent to the calling interface.)

### **Operation**

Datafill table LTDATA with the LTID information and DATATYPE of SERV. Enter Y in subfield AUDTRMT to allow audible treatment for calls having intercept treatment.

### **Translations table flow**

ISDN Treatments does not affect translations.

### **Limitations and restrictions**

ISDN Treatments is only functional for the originating PRI node and for the incoming trunk to the DMS-100 switch.

### **Interactions**

PRI ISDN Treatments has no functionality interactions.

### **Activation/deactivation by the end user**

PRI ISDN Treatments requires no activation or deactivation by the end user.

### **Station Message Detail Recording**

PRI ISDN Treatments does not affect Station Message Detail Recording.

### **Datafilling office parameters**

PRI ISDN Treatments does not affect office parameters.

### **Datafill sequence**

The following table lists the table that requires datafill to implement PRI ISDN Treatments.

#### **Datafill tables required for PRI ISDN Treatments**

<b>Table</b>	<b>Purpose of table</b>
LTDATA	To provide LTID data and enable the capability.

---

**PRI ISDN Treatments (continued)**

---

**Datafilling table LTDATA**

The following table shows the datafill specific to PRI ISDN Treatments for table LTDATA. Only those fields that apply directly to PRI ISDN Treatments are shown. For a description of the other fields, refer to the data schema section of this document.

**Datafilling table LTDATA**

Field	Subfield or refinement	Entry	Explanation and action
LTDKEY		see subfields	Logical terminal datakey. Datafill subfields LTGRP, LTNUM, and DATATYPE as one concatenated entry. Separate the three values with blanks. You are not prompted for the subfields individually.
	LTINDEX	see subfields	Logical terminal index. This is made up of subfields LTGRP and LTNUM.
	LTGRP	alphabetic	Logical terminal group. Enter the trunk group name.
	LTNUM	numeric (1 to 1022)	Logical terminal number. Enter the logical terminal number within the group.
	DATATYPE	SERV	Logical terminal data type. Enter SERV for service.
LTDRSLT		see subfields	Logical terminal result
	DATATYPE	SERV	Data type. Enter SERV for service.
	AUDTRMT	Y or N	<p>Audible treatments. Message to return when a speech or a 3.1 KHz audio call is terminated to intercept treatment for this LTID. The option applies to these treatments: VACT, UNDN, BLDN, PODN, CONF, MHLN, ATBS, TESS, TRBL and DNTR.</p> <p>Enter Y to return a PROGRESS message and provide inband treatment (a tone or announcement).</p> <p>Enter N to return a DISCONNECT message, with cause, and terminate the call.</p> <p><b>Note:</b> Only use when subfield DATATYPE is SERV.</p>

---

**PRI ISDN Treatments (end)**

---

**Datafill example for table LTDATA**

The following example shows sample datafill for table LTDATA.

**MAP display example for table LTDATA**

LTDKEY	LTDRSLT
<hr/>	
ISDN 505 SERV	SERV Y N SCREENED ALWAYS \$

**Error messages for table LTDATA**

Not applicable

**Translation verification tools**

PRI ISDN Treatments does not use translation verification tools.

**SERVORD**

PRI ISDN Treatments does not use SERVORD.

**History****SN06 (DMS)**

Applicability of AUDTRMT option specified for CR Q00757372.

History section added.

## **PRI Message Waiting indicator**

---

### **Ordering code**

Functionality group ordering code: NI000013

Functionality ordering code: Not applicable

### **Release applicability**

BCS36 and up

### **Prerequisites**

To operate, PRI Message Waiting Indicator (MWI) requires the NI000001 functional group.

### **Description**

The PRI Message Waiting Indicator capability provides a visual sign or a stuttered dial tone indicating that a message has been left at a simplified message desk interface (SMDI) for busy or unavailable called parties. SMDI provides a central answering service by integrating Call Forward (CFW), Uniform Call Distribution (UCD), Message Waiting (MW) and Executive Message Waiting (EMW) telephone features. The following figure illustrates how SMDI integrates these services.

## PRI Message Waiting indicator (continued)

### SMDI overview

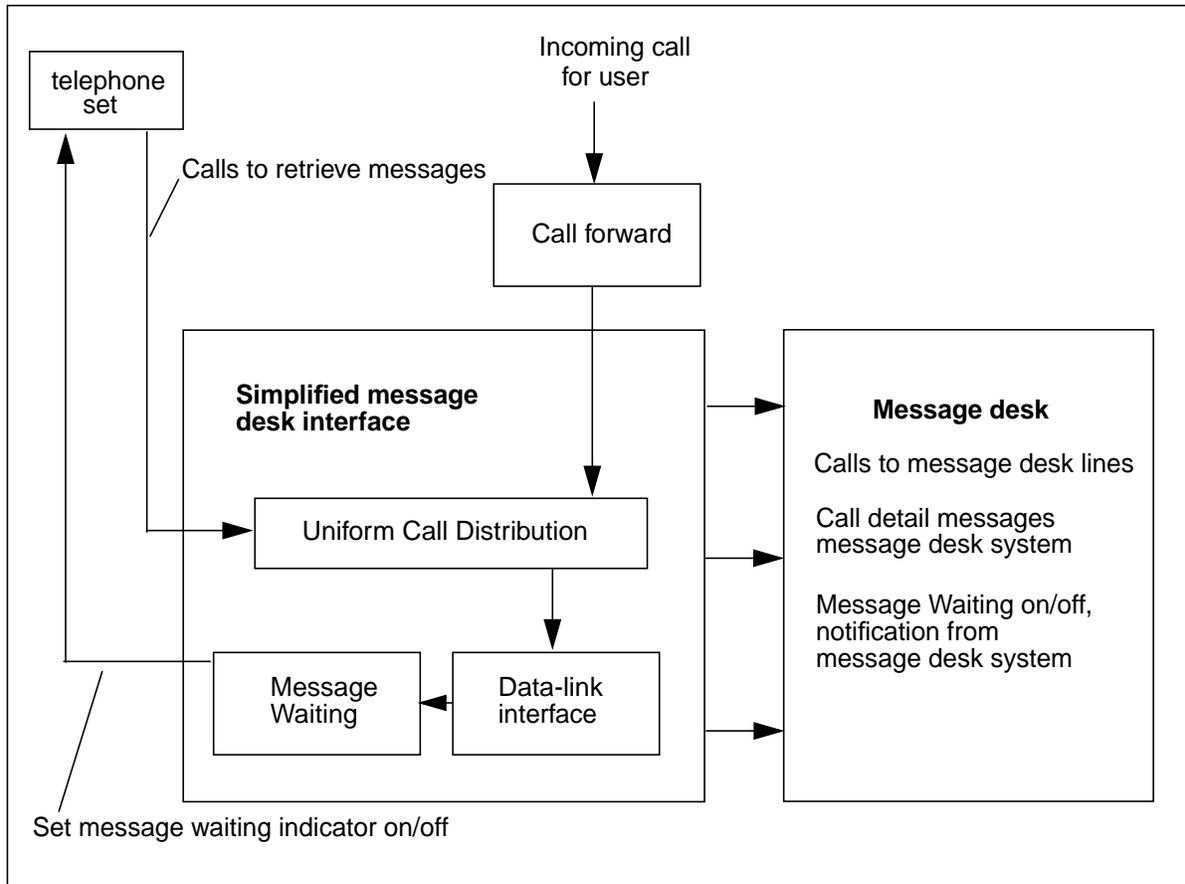

When a message is left at the SMDI, MWI is activated at the called party's telephone set. Once the called party retrieves the message, the MWI is deactivated.

MWI allows SMDI to leave a message when the calling and called parties are on switches connected by PRI trunks or connected by a combination of PRI trunks and Common Channel Signaling 7 (CCS7) links.

SMDI leaves a message by sending transaction capability application part (TCAP) messages. MWI routes TCAP messages through table MSGRTE to support PRI, CCS7, or PRI/CCS7 networks. The following figure illustrates how TCAP messages are routed over a PRI/CCS7 network using MWI.

## PRI Message Waiting indicator (continued)

### Routing TCAP messages thorough table MSGRTE

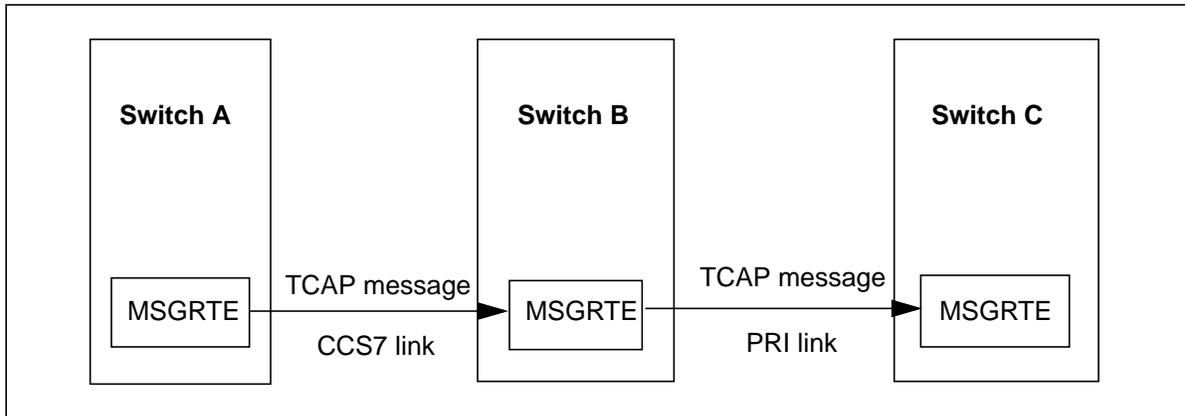

The MWI capability interworks between the DMS-100 switch and the Meridian 1 Options 11–81 (SL-1 system) private branch exchange (PBX). This will allow a Meridian 1 message center to activate or deactivate MWI for DMS-100 subscribers, or allow a DMS-100 message center to activate or deactivate MWI for Meridian 1 users. The DMS-100 switch provides network message system (NMS) to provide directory numbers (DN).

## Operation

Table NETNAMES, along with tables NCOS and IBNXLA, allows the operating company to datafill station information against a DN on a logical network basis. The NMSTBRTE option is in table NETNAMES. It routes TCAP messages by table MSGRTE. If NMSTBRTE is not defined, the TCAP messages are routed through the signaling connection control part (SCCP) network message system (NMS).

Table MSGRTE must be datafilled for NMSTBRTE to function. The table is indexed by a three-subfield key consisting of a network identifier (NETID) and two digit string. The data in the table is a list of routes made up of one to four route elements. Each route element in the route list uses a route selector: LOCAL, primary rate access (PRA), or SS7. When the selector is PRA, a PRI facility message is created and sent to the PRI facility process in the next switch. When the selector is SS7, an SCCP unit data message is created and sent to the interwork SCCP subsystem in the switch. These messages contain the TCAP information needed by MWI. The Network Ring Again capability also uses table MSGRTE. The following figure illustrates the MWI routing process using table MSGRTE.

---

## PRI Message Waiting indicator (continued)

---

### MWI routing using table MSGRTE

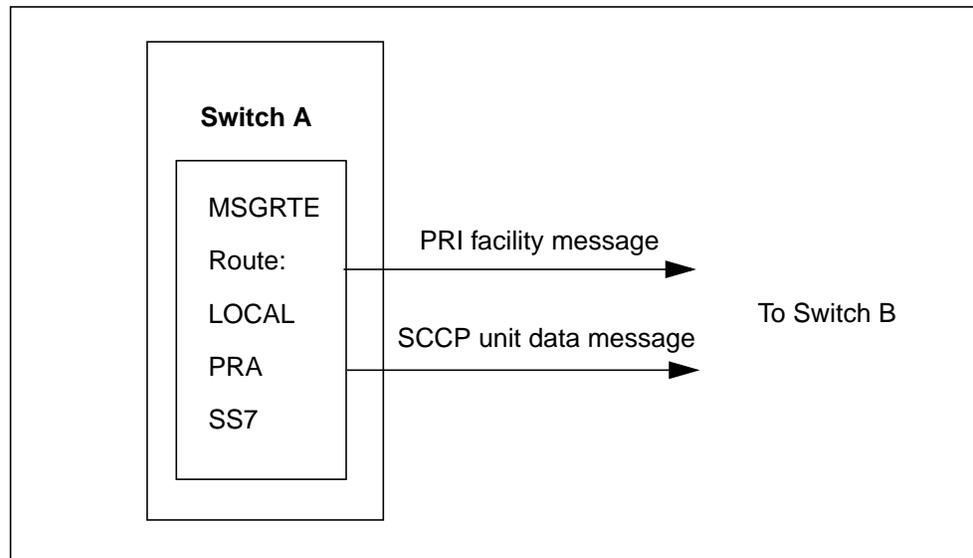

### Translation table flow

PRI Message Waiting Indicator does not affect translations.

### Limitations and restrictions

The following limitations and restrictions apply to PRI Message Waiting Indicator:

- MWI only functions for a DMS-100 switch linked to a DMS-100 switch, Meridian 1 Options 11–81 (SL-1 system), or Meridian 1 Options 111–211 (SL-100 system).
- MWI does not direct message waiting tone (MWT) notification to a remote telephone.
- It may not be possible to send a response message back when a switch with option NMSTBRTE routes a message to a switch without it. The first switch assumes, after the response time-out, that the feature activation has been unsuccessful.
- When MWI does not know the network name of the destination DN, the destination DN is sent as PUBLIC.

### Interactions

PRI Message Waiting Indicator has no functionality interactions.



---

## PRI Message Waiting indicator (continued)

---

### Activation/deactivation by the end user

PRI Message Waiting Indicator requires no activation or deactivation by the end user.

### Billing

PRI Message Waiting Indicator does not affect billing.

### Station Message Detail Recording

PRI Message Waiting Indicator does not affect Station Message Detail Recording.

### Datafilling office parameters

PRI Message Waiting Indicator does not affect office parameters.

### Datafill sequence

The following table lists the tables that require datafill to implement PRI Message Waiting Indicator. The tables are listed in the order in which they are to be datafilled.

#### Datafill tables required for PRI Message Waiting Indicator

Table	Purpose of table
NETNAMES	Defines the internal network names and their corresponding external network identifiers.
MSGRTE	Defines the routing of messages between switches. Assigns the capability to the logical network to which the end user belongs.

### Datafilling table NETNAMES

The following table shows the datafill specific to PRI Message Waiting Indicator for table NETNAMES. Only those fields that apply directly to PRI MWI are shown. For a description of the other fields, refer to the data schema section of this document.

#### Datafilling table NETNAMES (Sheet 1 of 2)

Field	Subfield	Entry	Explanation and action
NETNAMES		alphanumeric (up to 32 characters)	Network name. Enter the name of the network to which the customer group belongs.
EXTNETID		numeric (0 to 32 767)	External network identifier. Enter the unique number used to identify the network externally.

---

## PRI Message Waiting indicator (continued)

---

### Datafilling table NETNAMES (Sheet 2 of 2)

Field	Subfield	Entry	Explanation and action
NETDIGS		0 to 10	Network digits. Enter the number of digits used to identify field EXTNETID.
NETOPTS		see subfield	Network options
	OPTIONS	NMSTBRTE	Option. Enter NMSTBRTE to route the TCAP messages for MW by way of table MSGRTE. Enter a \$ to end the tuple.  <b>Note:</b> If NMSTBRTE is not defined, the regular method of routing through the SCCP NMS is used.

### Datafill example for table NETNAMES

The following example shows sample datafill for table NETNAMES.

### MAP display example for table NETNAMES

NETNAME	EXTNETID	NETDIGS	NETOPTS
CUSTNET1	2	7	( NMSTBRTE ) \$

### Error messages for table MSGRTE

Not applicable

## PRI Message Waiting indicator (continued)

### Datafilling table MSGRTE

The following table shows the datafill specific to PRI Message Waiting Indicator for table MSGRTE. Only those fields that apply directly to PRI MWI are shown. For a description of the other fields, refer to the data schema section of this document.

#### Datafilling table MSGRTE (Sheet 1 of 3)

Field	Subfield	Entry	Explanation or action
MSGRTEKEY		see subfields	Message route key. Datafill subfields NETID, FROMDIGS, and TODIGS as one concatenated entry. Separate the three values with blanks. You are not prompted for the subfields individually.
	NETID	alphanumeric (up to 32 characters)	Network identification. Enter the network name to which the customer group belongs.
	DIGRANGE	see subfields	Digit range. This is made up of subfields FROMDIGS and TODIGS.
	FROMDIGS	digits (up to 11)	From digits. Enter a digit string for the lower bound of the digit range to which the route list applies.
	TODIGS	digits (up to 11)	To digits. Enter a digit string for the upper bound of the digit range to which the route list applies.
MSGRTRES		see subfields	Message routes
	MSGRTSEL	LOCAL, PRA, SS7	<p>Message route selector. Enter LOCAL from the message to terminate locally at the DMS-100 switching node.</p> <p>Enter PRA for the message to route over a D-channel on a PRI trunk to the next node.</p> <p>Enter SS7 for the message to route over a CCS7 trunk to the next node. Enter a \$ to end the tuple.</p> <p><b>Note:</b> When the LOCAL selector is used, it must be the first and only route in a tuple.</p> <p>There can only be one SS7 selector and it must be the last selector in a tuple.</p>

---

**PRI Message Waiting indicator** (continued)
 

---

Datafilling table MSGRTE (Sheet 2 of 3)

Field	Subfield	Entry	Explanation or action
	TRKCLLI	alphanumeric	Trunk CLLI. Enter the trunk calling line identifier.  <b>Note:</b> Use when subfield MSGRTSEL is PRA.
	DPC	alphanumeric	Destination point code. Enter the valid point code of the switch that the message is to be sent to.  <b>Note:</b> Use when subfield MSGRTSEL is SS7.
	DELDIGS	numeric (0 to 15)	Delete digits. Enter a number from 0 to 15 for the digits to delete from the destination address in the message routing information.
	PREDIGS	digits (up to 11)	Prefix digits. Enter up to 11 digits for the digit string to prefix the destination address in the message routing information.
MSGRTRES	OPTION	NEWNET, NEWTOR	Option. Enter NEWNET for new network name. Enter NEWTOR for new type of route. Enter a \$ to end this subfield.  <b>Note:</b> Use when subfield MSGRTSEL is PRA or SS7. For SS7, use NEWNET only.  This subfield is optional.

**PRI Message Waiting indicator** (continued)

**Datafilling table MSGRTE (Sheet 3 of 3)**

Field	Subfield	Entry	Explanation or action
	NETNAME	alphanumeric (up to 32 characters)	<p>Network name. Enter the new network name that is to be used to replace the network identifier in the destination address in the message routing information.</p> <p><b>Note:</b> Use when the subfield OPTION is NEWNET.</p> <p>The network name must already exist in table NETNAMES.</p>
	TYPEOFRT	PUB, PVT	<p>Type of route. New route used in the DEST IE of a PRI facilitates message, as opposed to matching whether the network identifier is public or private. Enter PUB for public. Enter PVT for private.</p> <p><b>Note:</b> Use when the subfield OPTION is NEWTOR.</p>

**Datafill example for table MSGRTE**

The following example shows sample datafill for table MSGRTE.

**MAP display example for table MSGRTE**

		MSGRTKEY			MSGRTRES
<hr/>					
CUSTNET1	0000001	9999999			
	( PRA	CTOD	0	0	(NEWNET CUST1PVT)\$)\$

---

## PRI Message Waiting indicator (end)

---

### Error messages for table MSGRTE

The following error messages apply to table MSGRTE.

#### Error messages for table MSGRTE

Error message	Explanation and action
MSGRTE: LOCAL MUST BE FIRST ADN ONLY ROUTE IN LIST	An attempt was made to enter a tuple containing a LOCAL message route selector combined with PRA or SS7 message route selectors. LOCAL must be the only message route selector in a tuple.
MSGRTE: ONLY ONE SS7 SELECTOR, AND IT MUST BE THE LAST TUPLE TO BE ADDED	More than one SS7 message route selector is trying to be added. A SS7 selector is not the last tuple. Enter only one tuple with the SS7 selector and make it the last tuple added.
MSGRTE: NEWNET CANNOT BE SAME AS KEY NETID	The network name in the field MSGRTKEY entry is the same as the one entered in subfield NETNAME. Reenter a different name in subfield NETNAME.

### Translation verification tools

PRI Message Waiting Indicator does not use translation verification tools.

### SERVORD

PRI Message Waiting Indicator does not use SERVORD.

## PRI Network Name Delivery

---

### Ordering codes

Functional group ordering code: NI000013

Functionality ordering code: not applicable

### Release applicability

BCS36 and up

### Description

The PRI Network Name Delivery capability is an NI-1 feature that delivers name information across a PRI network composed of DMS Family switches including Meridian 1 private branch exchanges (PBX). This capability also supports interworking with the CCS7 integrated services digital network user part (ISUP) network. With interworking, the intermediate node does the protocol conversion.

The DISPLAY information element (IE) uses SETUP or NOTIFY Q.931 messages to carry the called party name, calling party name, and response information across the PRI interface. The following are the operational parts of the capability:

- The retrieval of the calling party name (and that of the originally called party name, if redirection occurs) from the originating node. This information is transported across a network and delivered to the terminating node to be displayed on the terminating terminal.
- The retrieval of connected party name from the terminating switch. This information is transported across a network and delivered to the originating node to be displayed on the originating terminal.
- Call redirection can occur at the terminating node while the originally called party's name is not present in the call establishment message received from the originating node. In this case, the originally called party's name is retrieved from the terminating node's database, and transported in the outgoing call establishment message.

### Operation

In table NETNAMES, the subfield OPTION allows PRI Network Name Delivery. Subfield NMXCHG defines which method (SETUP or QUERY) to use to deliver the name across the PRI network.

In table CUSTNTWK, the CLID entry in subfield OPTION determines if a line is allowed to display the connected party name for ONNEET and OFFNET calls, as defined in subfield CLIDOPT.

## PRI Network Name Delivery (continued)

The actions at the originating exchange depend on the method of transfer. With the SETUP method, the called party name is included in the SETUP message. With the QUERY method, the availability of the calling party name is implied, and a request for connected party information is in the SETUP message. Refer to “Operation flow for PRI Network Name Delivery at the terminating exchange” in this document.

The actions at the terminating exchange depend on the method of transfer. With the SETUP method, when the terminating exchange receives the SETUP message (which contains the name information in the DISPLAY IE), the information is transferred to the connected party (if applicable) and the switch continues to complete the call setup. With the QUERY method, the terminating exchange determines if the connected party needs the name information and sends the request to the originating exchange using the NOTIFY message. The call continues without waiting for the name information from the originating exchange. Refer to “Operation flow for PRI Network Name Delivery at the terminating exchange” in this document.

The following shows the operation flow for PRI Network Name Delivery at the originating exchange.

### Operation flow for PRI Network Name Delivery at the originating exchange

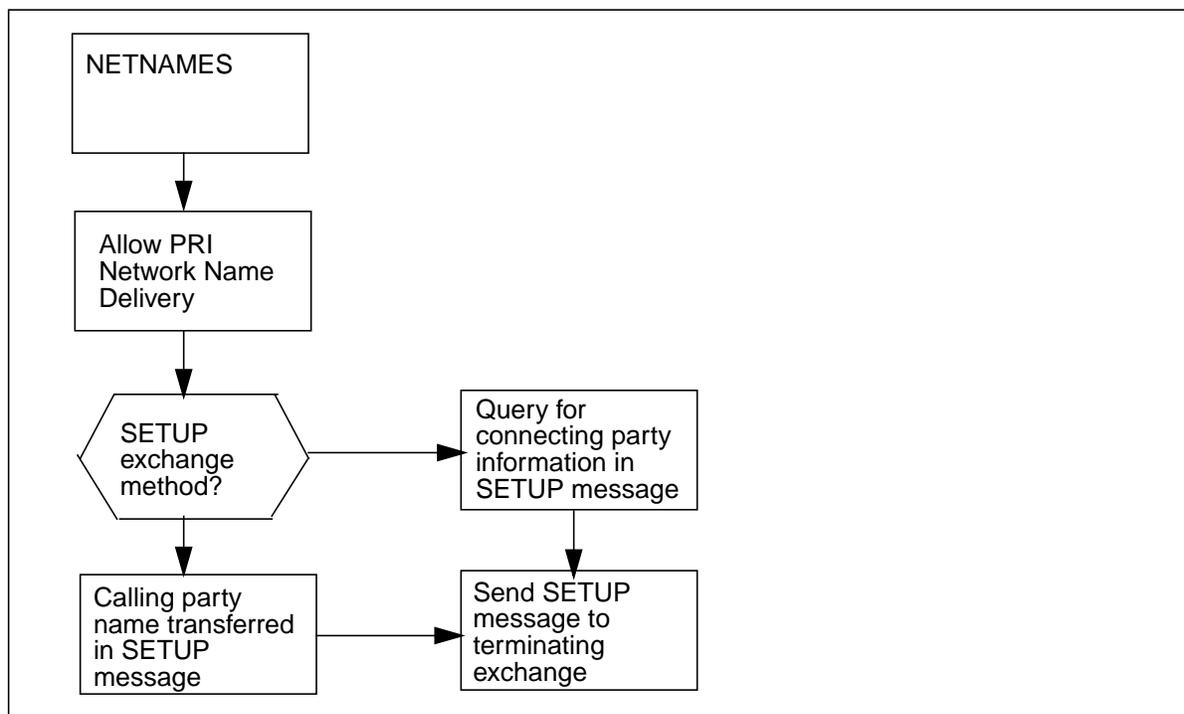



## PRI Network Name Delivery (continued)

The following shows the operation flow for PRI Network Name Delivery at the terminating exchange.

### Operation flow for PRI Network Name Delivery at the terminating exchange

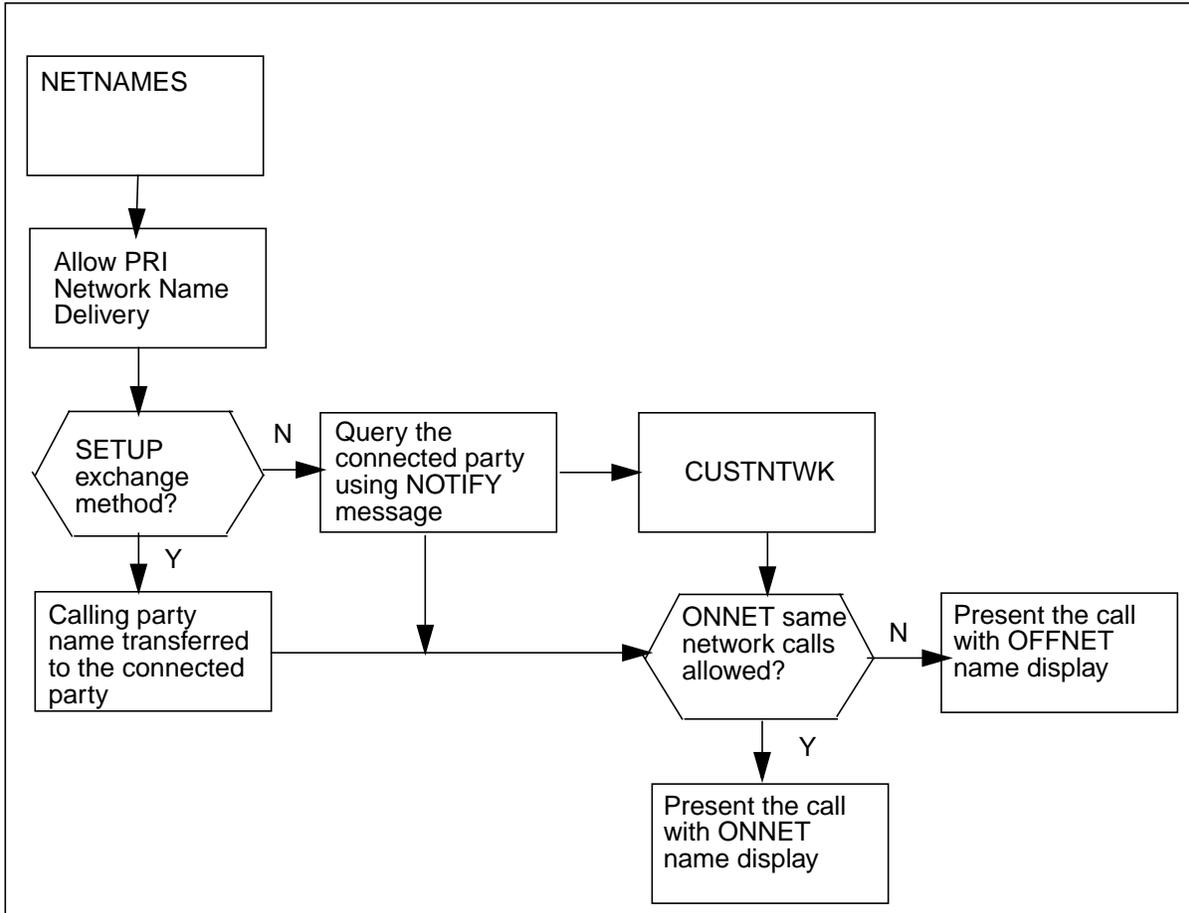

### Translations table flow

Datafill is required in tables NETNAMEN and CUSTNTWK.

---

## PRI Network Name Delivery (continued)

---

### Limitations and restrictions

The following limitations and restrictions apply to PRI Network Name Delivery.

- In multiple call forwarding situations, only the first redirected party name (or originally called party name) is displayed.
- For call forwarding using the QUERY transfer method, the name of the redirected party is not displayed when the first base stations are neither in the originating or terminating exchange.
- In some cases when the call configuration is modified after the call setup, the protocol control parameters are not exchanged (due to protocol limitations) and the name information is not transferred across the network.

### Interactions

PRI Network Name Delivery has no functionality interactions.

### Activation/deactivation by the end user

PRI Network Name Delivery requires no activation or deactivation by the end user.

### Billing

PRI Network Name Delivery does not affect billing.

### Station Message Detail Recording

PRI Network Name Delivery does not affect Station Message Detail Recording.

### Datafilling office parameters

PRI Network Name Delivery does not affect office parameters.

## PRI Network Name Delivery (continued)

### Datafill sequence

The following table lists the tables that require datafill to implement PRI Network Name Delivery. The tables are listed in the order in which they are to be datafilled.

#### Datafill tables required for PRI Network Name Delivery

Table	Purpose of table
NETNAMES	This table defines internal network names and their corresponding external network identifiers. The table assigns the capability to the logical network to which the end user belongs.
CUSTNTWK	This table associates an internal customer group name with a network name and calling in identification (CLID) used for the customer group throughout the network.

### Datafilling table NETNAMES

The following table shows the datafill specific to PRI Network Name Delivery for table NETNAMES. Only those fields that directly apply to PRI Network Name Delivery are shown.

#### Datafilling table NETNAMES (Sheet 1 of 2)

Field	Subfield or refinement	Entry	Explanation and action
NETNAME		alphanumeric (up to 32 characters)	Network name. Enter the name of the network to which the customer group belongs.
EXTNETID		numeric (0–32,600)	External network identifier. Enter the unique number used to identify the network externally.
NETDIGS		numeric (0–10)	Network digits. Enter the number of digits used to identify field EXTNETID.
NETOPTS		see subfields	Network options. This field consists of subfields OPTION and NMXCHG.

---

**PRI Network Name Delivery** (continued)
 

---

**Datafilling table NETNAMES (Sheet 2 of 2)**

Field	Subfield or refinement	Entry	Explanation and action
	OPTION	NMDSP	Option. Enter NMDSP for network name display. Enter \$ to end the tuple.
	NMXCHG	SETUP, QUERY	Name exchange method. Enter SETUP to transfer the name information in the SETUP message. Enter QUERY to check if the name is to be presented at the destination.

**Datafill example for table NETNAMES**

The following example shows sample datafill for table NETNAMES.

**MAP display example for table NETNAMES**

NETNAME	EXTNETID	NETDIGS	NETOPTS
CUSTNET1	2	7	(NMDSP QUERY) \$

---

**PRI Network Name Delivery** (continued)
 

---

**Datafilling table CUSTNTWK**

The following table shows the datafill specific to table CUSTNTWK. Only those fields that apply directly to PRI Network Name Delivery shown.

**Datafilling table CUSTNTWK (Sheet 1 of 2)**

Field	Subfield or refinement	Entry	Explanation and action
CUSTNAME		alphanumeric (up to 16 characters)	Customer name. Enter the internal name of the customer group.  <b>Note:</b> The customer group must be datafilled in table CUSTHEAD first.
NETNAME		alphanumeric (up to 32characters)	Network names. Enter the internal name of the network assigned in field NETNAME in table NETNAMES.
NETCGID		numeric (0–4096)	Network customer group identifier. Enter the number used to identify the customer group throughout the network.
OPTIONS		see subfields	Options. This field consists of subfields OPTION and CLIDOPT.

## PRI Network Name Delivery (continued)

### Datafilling table CUSTNTWK (Sheet 2 of 2)

Field	Subfield or refinement	Entry	Explanation and action
	OPTION	CLID	<p>Option. Enter CLID to indicate calling line identification. Enter \$ to end the tuple.</p> <p><b>Note:</b> To display the network name, this value must be assigned to the customer group of the party equipped with a display agent.</p> <p>To display the network name at the telephone, table CUSTSTN must be datafilled to indicate that a customer supports the capability. Table DNATTRS or table DNGRPS must be datafilled to add the name associated with a directory number.</p>
	CLIDOPT	ONNET, OFFNET	<p>Calling line identification option. Enter ONNET to enable Network Name Display for calls that originate and terminate in the same network. Enter OFFNET to enable Network Name Display for calls across different networks.</p>

### datafill example for table CUSTNTWK

The following example shows sample datafill for table CUSTNTWK.

### MAP display example for table CUSTNTWK

CUSTNAME	NETNAME	NETCGID	DNREVLXLA OPTIONS
GRP1	CUSTNET1	311	(CLID ONNET) \$ \$

## **PRI Network Name Delivery (end)**

---

### **Translation verification tools**

PRI Network Name Delivery does not use translation verification tools.

### **SERVORD**

PRI Network Name Delivery does not use SERVORD.

---

## PRI Network Ring Again

---

### Ordering code

Functionality group ordering code: NI000013

Functionality ordering code: Not applicable

### Release applicability

BCS36 and up

### Prerequisites

To operate, PRI Network Ring Again (NRAG) requires the NI000011 functional group.

### Description

The PRI Network Ring Again capability allows the Ring Again feature to work when the calling and called parties are on different switches connected by PRI trunks or by a combination of PRI and Common Channel Signaling 7 (CCS7) links. An end user located in any of the switching nodes in the combined PRI/CCS7 network can apply NRAG against a busy station located in any of the nodes in the same network and customer group.

This feature allows an end use who calls a busy station to queue against that station and be recalled when it becomes idle. When the end user accepts the recall, the original call is automatically set up again.

NRAG is implemented through messages that are passed back and forth between the originating and terminating switch. There can be intermediate switches between the originator and terminator. All switches must be connected by either PRI or CCS7. The party who activates NRAG is at the originating switch. The party who is busy is at the terminating switch. The NRAG messages are passed (interworked) from one switch to another using the message routing table MSGRTE. The messages contain the transaction capability application part (TCAP) information required by NRAG. The following figure illustrates how TCAP messages are routed over a PRI/CCS7 network using NRAG.



## PRI Network Ring Again (continued)

### Routing TCAP messages thorough table MSGRTE

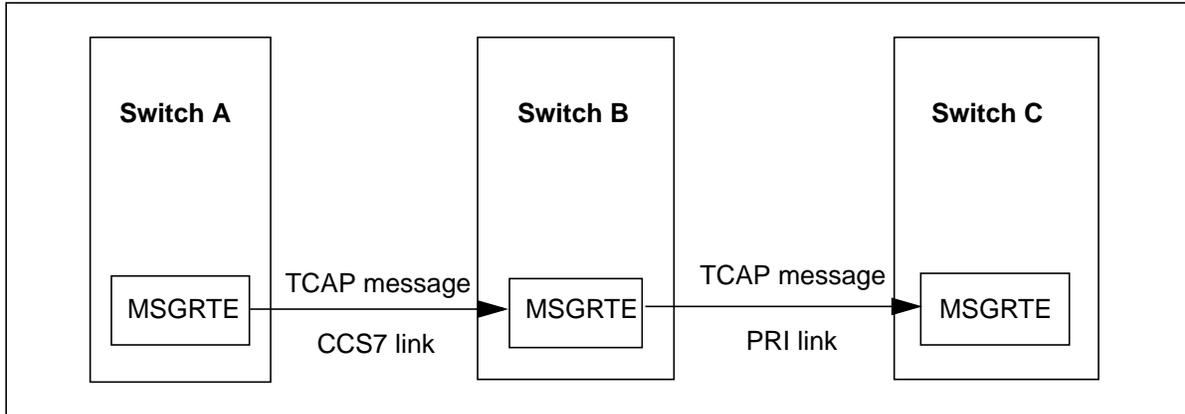

### Operation

Table NETNAMES is used to define the name of the logical network to which the end user belongs. The datafill for each network must be consistent on all switches involved. If routing through table MSGRTE is not chosen, the TCAP messages are routed through the signaling connection control part (SCCP) NRAG subsystem.

NRAG does not require a value in subfield OPTION in table NETNAMES to cause the TCAP messages to route through table MSGRTE. The options NINTNRAG and NMRTNRAG are required to prevent NRAG messages from being sent through table MSGRTE.

Table CUSTNTWK is used to associate the customer group with its logical networks and to specify NRAG.

Table MSGRTE determines where a message is routed. The table is concerned with routing messages and not with establishing call connections. All switches in the path must have appropriate datafill in table MSGRTE.

Table MSGRTE must be datafilled for NRAG to function. The table is indexed by a three-subfield key consisting of a network identifier (NETID) and two-digit subfields (FROM DIGS and TODIGS). The data in the table is a list of routes made up of one to four route elements. Each route element in the route list requires a LOCAL, PRA, or SS7 route selector. When the selector is PRA, a PRI facility message is created and sent to the PRI facility process in the next switch. When the selector is SS7, an SCCP unit data message is created and sent to the SCCP interwork system in the switch. These messages contain the TCAP information needed by NRAG. The NRAG capability also

---

## PRI Network Ring Again (continued)

---

uses table MSGRTE. The following figure illustrates the NRAG routing process using table MSGRTE.

### MWI routing using table MSGRTE

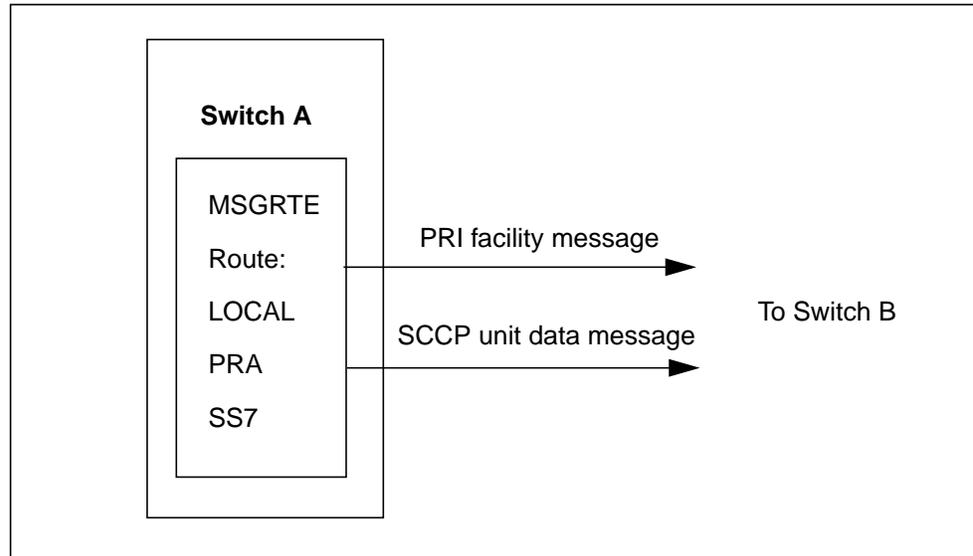

### Translation table flow

PRI Network Ring Again does not affect translations.

### Limitations and restrictions

The following limitations and restrictions apply to PRI Network Ring Again:

- NRAG does not work between two switches that have different options datafilled in table NETNAMES.
- In order for NRAG to interwork between PRI and CCS7, the CCS7 SCCP tables must be datafilled in addition to the tables covered in this chapter. Also, table TCAPTRID must have NRAG datafilled in the TCAP application field (TCAPAPPL).
- The original call must be entirely over PRI and/or SS7 trunks. NRAG is disallowed if any per trunk signaling (PTS) trunk is encountered.
- Subfield CALLTYPE in table LTCALLS must be either PVT or TIE for the logical terminal identifier (LTID). TIE can only be entered when integrated services access (ISA) is used.
- Tables DNATTRS and DNGRPS may alter the digits in the orientation information element (IE). When either table has an entry for the calling directory number (DN) and network, and the ADDRESS option is datafilled with alternate address digits, these digits are sent in the

## **PRI Network Ring Again** (continued)

---

origination IE. Table MSGRTE must be datafilled accordingly at the destination switch with the alternate digits.

- The calling and the called party must be members of the same network customer group. That is, the parties must belong to customer groups that have the same network customer group identifier infield NETCGID in table CUSTNTWK. The actual names of the customer groups need not be the same at each switch.
- Field NETNAME datafilled in each switch does not have to be the same. However, field EXTNETID must be the same at each switch. The EXTNETID entry is the external network identifier that is passed from switch to switch for NRAG. The DMS-100 switch converts the external identifier to a network name at each switch and uses the network name to access table MSGRTE.
- In order for NRAG to interwork between PRI and CCS7, the CCS7 SCCP tables must have additional datafill. Use the new subsystem (SS) name INTERWRK and the new global title (GT) name PRAGT.

### **Interactions**

PRI Network Ring Again has no functionality interactions.

### **Activation/deactivation by the end user**

PRI Network Ring Again requires no activation or deactivation by the end user.

### **Billing**

PRI Network Ring Again does not affect billing. The NRAG callback is billed as a normal call.

### **Station Message Detail Recording**

PRI Network Ring Again does not affect Station Message Detail Recording.

### **Datafilling office parameters**

PRI Network Ring Again does not affect office parameters.

---

## PRI Network Ring Again (continued)

---

### Datavill sequence

The following table lists the tables that require datavill to implement PRI Network Ring Again. The tables are listed in the order in which they are to be datavilled.

#### Datavill tables required for PRI Network Ring Again

Table	Purpose of table
NETNAMES	Defines the internal network names and their corresponding external network identifiers. Assigns the capability to the logical network to which the end user belongs.
CUSTNTWK	Associates an internal customer group name with a network name and calling line identification (CLID) used for the customer group throughout the network.
MSGRTE	Defines the routing of messages between switches.

### Datavilling table NETNAMES

The following table shows the datavill specific to PRI Network Ring Again for table NETNAMES. Only those fields that apply directly to PRI NRAG are shown. For a description of the other fields, refer to the data schema section of this document.

#### Datavilling table NETNAMES (Sheet 1 of 2)

Field	Subfield	Entry	Explanation and action
NETNAMES		alphanumeric (up to 32 characters)	Network name. Enter the name of the network to which the customer group belongs.
EXTNETID		numeric (0 to 32 767)	External network identifier. Enter the unique number used to identify the network externally.
NETDIGS		numeric (0 to 10)	Network digits. Enter the number of digits used to identify field EXTNETID.
NETOPTS		see subfield	Network options. This field consists of subfield OPTION.
	OPTION	FACREJ, NINTNRAG, NMRTNRAG	Option. Enter FACREJ for facility reject. The facility reject message is sent to the originator when the facility message cannot be routed for some reason.

## PRI Network Ring Again (continued)

### Datafilling table NETNAMES (Sheet 2 of 2)

Field	Subfield	Entry	Explanation and action
			<p>Enter NINTNRAG for no interworking NRAG. The network send its NRAG connectionless SS7 message to the feature specified by the TCAP application field (TCAPAPPL) in table TCAPTRID.</p> <p>Enter NMRTNRAG for no message route NRAG. The network routes its NRAG connectionless SS7 message by the digits and point codes returned in the ISDN user part (ISUP) RELEASE message instead of using table MSGRTE.</p> <p>Enter a \$ to end the tuple.</p> <p><b>Note:</b> Options NINTNRAG and NMRTNRAG only apply to NRAG when the original call is made over an SS7 trunk. Both options are datafilled together for a NETNAME. If both options are datafilled, table MSGRTE is not accessed during routing.</p> <p>When NINTNRAG is not datafilled, the network uses the INTERWRK RCAP application. Option NINTNRAG can only be datafilled for a network when MNRTNRAG is datafilled.</p> <p>Not datafilling NMRTNRAG or having a pure PRI network causes the NRAG messages to be routed by table MSGRTE.</p>

### Datafill example for table NETNAMES

The following example shows sample datafill for table NETNAMES.

### MAP display example for table NETNAMES

NETNAME	EXTNETID	NETDIGS	NETOPTS
CUSTNET1	1024	7	( NMSTBRTE ) \$

---

**PRI Network Ring Again** (continued)

---

**Datafilling table CUSTNTWK**

The following table shows the datafill specific to PRI Network Ring Again for table CUSTNTWK. Only those fields that apply directly to PRI NRAG are shown. For a description of the other fields, refer to the data schema section of this document.

**Datafilling table CUSTNTWK (Sheet 1 of 2)**

Field	Subfield	Entry	Explanation or action
CUSTNAME		alphanumeric (up to 16 characters)	Customer name. Enter the internal name of the customer group.  <b>Note:</b> The customer group must be datafilled in table CUSTHEAD first.
NETNAME		alphanumeric (up to 32 characters)	Network name. Enter the internal name of the network assigned in field NETNAME in table NETNAMES.
NETCGID		numeric (0 to 4096)	Network customer group identifier. Enter the number used to identify the customer group throughout the network.
OPTIONS		see subfield	Options. This field consists of subfield OPTION and refinements.
	OPTION	NTWKRAG	Option. Enter NTWKRAG for NRAG. Enter a \$ to end the tuple.
	TIMEOUT	numeric (10 to 60)	Time-out. Enter the number of seconds of ringing desired to alert the calling party that the called party is now idle.
	ORIGDUR	numeric (5 to 30)	Originator during time-out. Enter the number of minutes that the NRAG request at the originating switch is to remain active.
	ORIGRTY	numeric (2 to 10)	Originator retry time-out. Enter the number of seconds that the originator waits after sending out a TCAP QUERY message before sending out another message or ending.
	TERMDUR	numeric (5 to 31)	Terminator duration time-out. Enter the number of minutes that the NRAG request at the terminating switch must remain active.  <b>Note:</b> This time-out value must be greater than the entry in subfield ORIGDUR.

**PRI Network Ring Again** (continued)

**Datafilling table CUSTNTWK (Sheet 2 of 2)**

Field	Subfield	Entry	Explanation or action
	TERMGRD	numeric (1 to 6)	Terminator guard time-out. Enter the number of seconds that the terminator must wait after the receiver goes on hook before sending a message to the originator to indicate idleness.
	TERMQAD	numeric (5 to 40)	Terminator queue advance time-out. Enter the number of seconds that the terminator switch must wait before sending out called party free messages to different originators.
	NETOPT	ONNET or OFFNET	Network option. Enter ONNET to enable NRAG for calls that originate and terminate in the same network  Enter OFFNET to enable NRAG for calls across different networks.

**Datafill example for table CUSTNTWK**

The following example shows sample datafill for table CUSTNTWK.

**MAP display example for table CUSTNTWK**

CUSTNAME	NETNAME	NETCGID	DNREVLXLA OPTIONS
FRP1	CUSTNET1	311	\$
		(NTWKRAG 10 5 2 5 1 5 ONNET)	\$

## PRI Network Ring Again (continued)

### Datafilling table MSGRTE

The following table shows the datafill specific to PRI Network Ring Again for table MSGRTE. Only those fields that apply directly to PRI NRAG are shown. For a description of the other fields, refer to the data schema section of this document.

#### Datafilling table MSGRTE (Sheet 1 of 2)

Field	Subfield	Entry	Explanation or action
MSGRTEKEY		see subfields	Message route key. Datafill subfields NETID, FROMDIGS, and TODIGS as one concatenated entry. Separate the three values with blanks. You are not prompted for the subfields individually.
	NETID	alphanumeric (up to 32 characters)	Network identification. Enter the network name to which the customer group belongs.
	DIGRANGE	see subfields	Digit range. This is made up of subfields FROMDIGS and TODIGS.
	FROMDIGS	up to 11	From digits. Enter a digit string for the lower bound of the digit range to which the route list applies.
	TODIGS	up to 11	To digits. Enter a digit string for the upper bound of the digit range to which the route list applies.
MSGRTRES		see subfields	Message routes
	MSGRTSEL	LOCAL, PRA, SS7	Message route selector. Enter LOCAL from the message to terminate locally at the DMS-100 switching node. Enter PRA for the message to route over a D-channel on a PRI trunk to the next node. Enter SS7 for the message to route over a CCS7 trunk to the next node. Enter a \$ to end the tuple.  <b>Note:</b> LOCAL must be the first and only route in a tuple.  There can only be one SS7 selector and it must be the last selector in a tuple.
	TRKCLLI	alphanumeric (1 to 16 characters)	Trunk CLLI. Enter the trunk calling line identifier.  <b>Note:</b> Use when field MSGRTSEL is PRA.



## PRI Network Ring Again (continued)

### Datafilling table MSGRTE (Sheet 2 of 2)

Field	Subfield	Entry	Explanation or action
MSGRTRES	DPC	numeric	Destination point code. Enter the valid point code of the switch that the message is to be sent to.  <b>Note:</b> Use when field MSGRTSEL is SS7.
	DELDIGS	numeric (0 to 15)	Delete digits. Enter a number to specify the digits to delete from the destination address in the message routing information.
	PREDIGS	up to 11	Prefix digits. Enter the digit string to prefix the destination address in the message routing information.
	OPTION	NEWNET	Option. Enter NEWNET for new network name. Enter a \$ to end this subfield.  Use when subfield MSGRTSEL is PRA or SS7. For SS7, use NEWNET only.  <b>Note:</b> This subfield is optional.
	NETNAME	alphanumeric (up to 32 characters)	Network name. Enter the new network name that is to be used to replace the network identifier in the destination address in the message routing information.  <b>Note:</b> The network name must already exist in table NETNAMES.

### Datafill example for table MSGRTE

The following example shows sample datafill for table MSGRTE.

### MAP display example for table MSGRTE

MSGRTKEY	MSGRTRES
CUSTNET1	000001 9999999
( PRA	CTOD 0 0 (NEWNET CUST1PVT)\$)\$

---

## PRI Network Ring Again (end)

---

### Error messages for table MSGRTE

The following error messages are generated if table MSGRTE is datafilled incorrectly.

#### Error messages for table MSGRTE

Error message	Explanation and action
MSGRTE: LOCAL MUST BE FIRST AND ONLY ROUTE IN LIST	LOCAL is not the only message route datafilled in tuple. LOCAL must be the only message route selector in a tuple.
MSGRTE: ONLY ONE SS7 SELECTOR, AND IT MUST BE THE LAST TUPLE TO BE ADDED	More than one SS7 message route selector is datafilled. A SS7 selector is not the last tuple. Enter only one tuple with the SS7 selector and make it the last tuple added.
MSGRTE: NEWNET CANNOT BE SAME AS KEY NETID	The network name in the field MSGRTKEY entry is the same as the one entered in subfield NETNAME. Reenter a different name in subfield NETNAME.

### Translation verification tools

PRI Network Ring Again does not use translation verification tools.

### SERVORD

PRI Network Ring Again does not use SERVORD.

## **PRI SUSP for CNAME**

---

### **Ordering codes**

Functional group ordering code: NI000030

Functionality ordering code: not applicable

### **Release applicability**

NA010 and up

### **Prerequisites**

This document includes all the data table information for this functionality. Complete use of this functionality can require software or hardware not described in this document.

### **Description**

PRI SUSP for CNAME provides subscriber usage-sensitive pricing (SUSP) billing for the ISDN PRI Calling Name Delivery (I-CNAM) feature.

PRI SUSP for CNAME also allows the I-CNAM feature to support interactions with the following services:

- advanced intelligent network (AIN)
- calling number screening and editing features
- redirection (call forwarding) features

This functionality complies with TR-NWT-862, Automatic Message Accounting Generic Requirements, Issue 3, June 1993, Supplement 1.

### **Operation**

The I-CNAM feature provides the ISDN PRI called party with the name of the calling party. The PRI Calling Name Delivery feature implemented this functionality in NA009.

The DMS switch retrieves the calling name from one of the following three sources:

- the ISDN user part (ISUP) initial address message (IAM)
- a local lookup table
- a central name database using transaction capabilities application part (TCAP) messaging

---

## PRI SUSP for CNAME (continued)

---

PRI-CNAM only affects the public network and is only supported within the National ISDN primary rate interface (NI-PRI). The following peripheral types support PRI I-CNAM:

- ISDN line trunk controller (LTC ISDN)
- ISDN digital trunk controller (DTC ISDN)

### I-CNAM feature interactions

PRI SUSP for CNAME allows the I-CNAM feature to support interactions with the following features:

- AIN
- calling number screening and editing features
- redirection (call forwarding) features

### Limitations and restrictions

As of the NA010 release, AMA record generation for calling number delivery is not supported.

### Interactions

The following paragraphs describe the interactions between PRI SUSP for CNAME and other functionalities.

#### Advanced intelligent network

PRI SUSP for CNAME enhances I-CNAM to support AIN.

Assume that AIN is triggered before I-CNAM and that AIN creates a new calling party DN. In this example, I-CNAM uses the AIN calling party DN to determine the calling party name. If AIN does not create a new calling party DN, I-CNAM uses the original calling party DN to obtain the name. I-CNAM also uses the presentation indicator (PI) set by AIN.

Currently, the AIN Bellcore specification supports an AIN calling party name. However, DMS-100 switch implementation of AIN 0.2 does not support the retrieval of the calling party name.

Processing for I-CNAM is one of the last steps in routing a call to its destination. Consequently, it is not possible for AIN to be triggered after I-CNAM, so there are no interactions between AIN and I-CNAM in this case.

#### Calling number screening and editing features

PRI SUSP for CNAME enhances I-CNAM to support calling number screening and editing features.

## PRI SUSP for CNAME (continued)

---

Calling number screening and editing features can change the calling DN during translations on the originating side of the call. These features change the calling DN by storing the new calling DN in an extension block. I-CNAM is triggered on the terminating side of the call and uses the calling DN from the appropriate extension block.

### Redirection features

PRI SUSP for CNAME enhances I-CNAM to support redirection features.

Redirection features can change the DN of the calling party. I-CNAM uses the original calling party DN and PI, not the DN and PI of the redirected party.

### Activation/deactivation by the end user

PRI SUSP for CNAME requires no activation or deactivation by the end user.

### Billing

The following paragraphs describe billing associated with the PRI SUSP for CNAME feature.

#### Overview

PRI SUSP For CNAME enhances I-CNAM to generate an AMA record when one of the following occurs

- an SUSP audit
- the operating company deletes or changes the billing DN in table TRKGRP
- the operating company disables SUSP billing for a PRI LTID by setting refinement CNAM\_SUSP for option TCAP\_CNAM in table LTDATA to N

*Note:* When the operating company disables SUSP billing for a PRI LTID, a billing record is not immediately generated. The next SUSP audit generates a billing record for the LTID if the calling name delivery AVAIL and UNAVAIL counts are non-zero, to ensure that the counts are not lost.

- the operating company deletes the PRI LTID from table LTDATA

SUSP pricing allows billing for the I-CNAM feature on a usage basis rather than a flat-rate basis. An office-level control for SUSP pricing in table AMAOPTS (option SUSP) allows I-CNAM to generate SUSP AMA records.

The DMS switch generates an AMA record for each I-CNAM SUSP display subscriber as scheduled in table AMAOPTS through option CIDSUSPAUD. The CIDSUSPAUD audit must occur at least once daily to produce the records for all CLASS SUSP display subscribers. Each record

---

## PRI SUSP for CNAME (continued)

---

provides the calling information available and unavailable counts for the I-CNAM SUSP feature assigned to a PRI LTID. The delivery count fields are read-only fields.

When the DMS switch attempts to deliver the calling party name, the switch counts the number of times the name is available or unavailable. A scheduled audit occurs at a minimum of once every 24 hours to collect these counts. PRI SUSP for CNAME enhances the existing SUSP audit process to gather the counts for I-CNAM delivery.

The SUSP AMA record includes the calling name delivery AVAIL and UNAVAIL counts. The AVAIL count stores the number times the switch deliver a calling name to the subscriber. The UNAVAIL count stores the number of times I-CNAM was provisioned but the name was not available for delivery. Separate counts are stored for voice and data name delivery.

### Required provisioning for SUSP billing

The operating company must perform the following provisioning to enable SUSP billing for terminating PRI LTID. Bellcore LAMA and CAMA packages must be present in the office.

- In table LINEATTR, add a pretranslator name, for example, INCK or P622 to route calls.
- In table STDPRTCT, position on the pretranslator and access subtable STDPRT, Add the option DD (direct dial).
- In table TRKGRP, assign the billing DN. Because a PRI LTID does not terminate to a set, the switch uses the trunk group billing DN to generate AMA records.

*Note:* The supported trunk types are PRA (primary rate access) and IBNT2 (IBN 2-way).

- Assign I-CNAM to trunk LTID in table LTDATA. Set refinement CNAM\_SUSP for option TCAP\_CNAM to Y.
- Enable calling number (CGN) delivery on the trunk LTID in table LTDATA by setting subfield CGNDELV to ALWAYS.
- In table AMAOPTS, set option SUSP to ON to enable SUSP billing.
- In table AMAOPTS, set option CIDSUSPAUD to specify frequency of the SUSP audit.

*Note:* Office parameter ISDNBRI\_CNAMD\_CND\_AMA in table OFCENG determines whether the switch generates separate or combined AMA records for calling name delivery and calling number

## PRI SUSP for CNAME (continued)

---

delivery. Because PRI SUSP for CNAME pertains only to calling name delivery billing, this office parameter does not apply to this feature.

### AMA record for SUSP I-CNAM

For PRI trunks with SUSP I-CNAM, the calling name delivery AMA record has structure code 110, call code 264, and CLASS feature code 082.

The DMS switch appends module code 71 to the SUSP I-CNAM AMA record to indicate the bearer capability (BC). The following BCs are supported: 3\_1KHZ and 64KDATA. All voice calls have a BC of 3-1KHZ. All data calls have a BC of 64KDATA. Figure shows a SUSP I-CNAM AMA record generated with the ALLDUMP command for a voice call. Module 071 is appended to the record to indicate the BC. The release cause value is 16 (normal clearing).

#### Example of a SUSP I-CNAM AMA record—voice call

```
*HEX ID:AA STRUCTURE CODE:401104 CALL CODE:264C SENSOR TYPE:036C
SENSOR ID:0000000C REC OFFICE TYPE:036 REC OFFICE ID:0000000C
CLASS FEATURE:082C DATE:80601C CONNECT TIME:2116484C NPA:613C
DIR NUMBER:1231234C AVAIL COUNT:00002C UNAVAIL COUNT:0000C
MODULE CODE:071C BEARER CAPABILITY:102C NETWORK INTERWORKING:0C
RELEASE CAUSE INDICATOR:00016C MODULE ODE:000C
```

Figure shows a SUSP I-CNAM AMA record generated with the CALLDUMP command for a data call. Module code 071 is appended to the record to indicate the BC. The release cause value is 16 (normal clearing).

#### Example of a SUSP I-CNAM AMA record—data call

```
*HEX ID:AA STRUCTURE CODE:401104 CALL CODE:264C SENSOR TYPE:036C
SENSOR ID:0000000C REC OFFICE TYPE:036 REC OFFICE ID:0000000C
CLASS FEATURE:082C DATE:80601C CONNECT TIME:2116484C NPA:613C
DIR NUMBER:1231234C AVAIL COUNT:00000C UNAVAIL COUNT:0000C
MODULE CODE:071C BEARER CAPABILITY:203C NETWORK INTERWORKING:0C
RELEASE CAUSE INDICATOR:00016C MODULE ODE:000C
```

## Station Message Detail Recording

PRI SUSP for CNAME does not affect Station Message Detail Recording.

**PRI SUSP for CNAME** (continued)**Datafilling office parameters**

PRI SUSP for CNAME does not affect office parameters.

**Datafill sequence**

The following table lists the table that requires datafill to implement PRI SUSP for CNAME.

Table	Purpose of table
LTDATA	Logical Terminal Data. This table stores service-related data associated with an LTID.

**Datafilling table LTDATA**

PRI SUSP for CNAME adds refinement CNAM\_SUSP to option TCAP\_CNAM for DATATYPE SERV. To enable SUSP billing for a PRI LTID with I-CNAM, set refinement CNAM\_SUSP to Y.

The following table shows the datafill specific to PRI SUSP for CNAME for table LTDATA. Only those fields that apply directly to PRI SUSP for CNAME are shown.

**Datafilling table LTDATA (Sheet 1 of 3)**

Field	Subfield or refinement	Entry	Explanation and action
LTDKEY		see subfields	Logical terminal data key. This field consists of subfields LTGRP, LTNUM, and DATATYPE.
	LTGRP	alphanumeric (maximum 8 characters)	Logical terminal group. Enter the logical terminal group (LTG) name.
	LTNUM	1 to 1022	Logical terminal number. Enter the logical terminal number within the group. The quantity of group numbers is restricted. A maximum of 31 entries is allowed.
	DATATYPE	SERV	Logical terminal data type. Enter the logical terminal data type SERV for service-related data associated with an LTID or PRA interface.



**PRI SUSP for CNAME** (continued)

## Datafilling table LTDATA (Sheet 2 of 3)

Field	Subfield or refinement	Entry	Explanation and action
LTDRSLT		see subfield	Logical terminal result. This field consists of subfield DATATYPE.
	DATATYPE	SERV	Logical terminal data type. Enter the logical terminal data type SERV for service-related data associated with an LTID or PRA interface. Datafill refinements AUDTRMT, CGNREQD, CGNDELV, CDNDELV, and OPTION.
	AUDTRMT	Y or N	<p>Audible treatments. This field determines whether in-band tones and announcements are provided instead of disconnect with cause when treatments are applied to calls from this LTID.</p> <p>Enter Y (yes) to enable in-band treatment procedures for originating PRI calls with BC of speech or 3.1-kHz audio.</p> <p><b>Note:</b> To make two BCs compatible with TBCT, datafill BCs in table BCCOMPAT before you datafill table LTDATA.</p> <p>Enter N (no) to disable in-band treatment procedures and handle call clearing as it was originally handled.</p>
	CGNREQD	Y or N	Calling party number required. Enter Y to indicate that the calling number must be provided by the calling user equipment. Otherwise, enter N.
	CGNDELV	ALWAYS, NEVER, or SCREENED	<p>Calling party number delivery. This field indicates when the calling number is delivered to the called interface. Enter one of the following values:</p> <ul style="list-style-type: none"> <li>ALWAYS indicates that the actual calling number with the PI is sent.</li> <li>NEVER indicates that the calling number with the PI is not sent.</li> <li>SCREENED (the default value) indicates that if the PI is private, the calling number is not sent (it is replaced by asterisks).</li> </ul>

**PRI SUSP for CNAME** (continued)**Datafilling table LTDATA (Sheet 3 of 3)**

Field	Subfield or refinement	Entry	Explanation and action
	CDNDELV	NEVER or ALWAYS	Called party number delivery. This field determines whether the called party number is delivered to the called interface. Enter one of the following values: <ul style="list-style-type: none"> <li>NEVER indicates that the called party number is not delivered to the called interface.</li> <li>ALWAYS indicates that the called party number is always delivered to the called interface.</li> </ul>
	OPTION	TCAP_CNAM	Option. This field contains options for PRI services. Enter TCAP_CNAM and enter the datafill for refinement CNAM_SUSP.
	CNAM_SUSP	Y, N	Enter Y to enable SUSP billing for the PRI LTID. Enter N to disable SUSP billing for the PRI LTID. The default is N.  <b>Note:</b> Before setting refinement CNAM_SUSP to Y for a PRI LTID, the operating company must assign the billing DN in table TRKGRP (subfield BILLDN).

**Datafill example for table LTDATA**

The following example shows sample datafill for table LTDATA with DATATYPE SERV and option TCAP\_CNAM. Refinement CNAM\_SUSP is set to Y (SUSP billing enabled) in both tuples.

**MAP display example for table LTDATA**

LTDKEY			LTDRSLT				
ISDN	381	SERV					
			SERV	Y	Y	ALWAYS	ALWAYS (TCAP_CNAM Y)\$
ISDN	383	SERV					
			SERV	Y	Y	ALWAYS	ALWAYS (TCAP_CNAM Y)\$

---

## PRI SUSP for CNAME (end)

---

### Error messages for table LTDATA

The following error and warning messages apply to table LTDATA.

#### Error messages for table LTDATA

Error message	Explanation and action
THE OPTION IS ONLY VALID FOR NI-PRI VARIANT	This warning message displays if the operating company attempts to provision the TCAP_CNAM option against a non-NI-PRI variant.
ISDNCIRCUIT IN TABLE AMAOPTS MUST BE ENABLED	This error message displays if parameter ISDNCIRCUIT in table AMAOPTS is not enabled.
SUSP ONLY ALLOWED IN BELLCORE AMA FORMAT OFFICES	This error message displays if parameter AMA_FORMAT in table AMAOPTS is not set to ATT_AMA_FORMAT to indicate Bellcore billing.
Billing DN not assigned in table TRKGRP	This warning message displays if the operating company has not assigned a billing DN in table TRKGRP.
Number of Billing DN digits not in range	This warning message indicates that the billing DN in table TRKGRP is outside the range of 3 to 10 digits.

### Translation verification tools

PRI SUSP for CNAME does not use translation verification tools.

### SERVORD

PRI SUSP for CNAME does not use SERVORD.

---

## PRI Two B-channel Transfer

---

### Ordering codes

Functional group ordering code: NI000015

Functionality ordering code: NI000018

### Release applicability

NA009 and up

### Prerequisites

PRI Two B-channel Transfer has no prerequisites.

### Description

The PRI Two B-channel Transfer (TBCT) capability on National ISDN 2 (NI-2) PRI trunks gives CPE more efficient use of trunk connections for calling traffic. With a PBX, or network of PBXs, multiple call forward and transfers are typical. When a forwarded or transferred call is set up using two B-channels in a PRI trunk, the original channels can be released and made available for future calls. the controller can be an intelligent peripheral (IP), a PBX, or other CPE.

The CPE requests TBCT by sending a facility message with a TBCT invoke component to the service switching point (SSP). If the SSP determines that all validation criteria pass (for example, bearer capabilities and feature interactions), the SSP performs TBCT. The SSP responds with a facility message that acknowledges the TBCT request.

All billing, including AMA billing, proceeds as if the TBCT never occurred.

*Note:* For per trunk signaling (PTS) trunks, the system denies TBCT during the alerting phase. PTS trunks outpulse digits to the far end. TBCT disrupts digit outpulsing, and the call cannot be completed.

### Operation

PRI TBCT provides the capability to connect two independent calls (the calls can be on the same or different NI-2 interfaces between the controller and the DMS switch) at the request of the controller. the system sends this request to the SSP in the form of a Q.931 FACILITY message containing an invoke component coded with a TBT operation identifier.

If requesting TBCT across D-channels, the D-channel identifier must be present in the FACILITY message for the request.

## PRI Two B-channel Transfer (continued)

The SSP processes the request as follows:

- validates the request for both calls
- bridges the calls (providing a speech path) if validation passes. Otherwise returns an error message and leaves existing calls connected
- disconnects the calls to the controller if not already initiated by the controller

TBCT across D-channels requires the following:

- The controller must provide the D-channel identifier of the second PRI interface to correctly identify the second call to be bridged (the first call being the call that receives the TBCT request).
- The D-channel identifier request (dCIRequest) can be independent of both TBCT and the calls to be bridged. The D-channel identifier can be requested on any call and stored for later use by the controller. The controller requests TBCT to be performed on the call receiving the TBCT request and a second call identified in the TBCT request by its linkid and D-channel identifier.

Figure shows an example for PRI Two B-channel Transfer.

### Example of PRI Two B-channel transfer

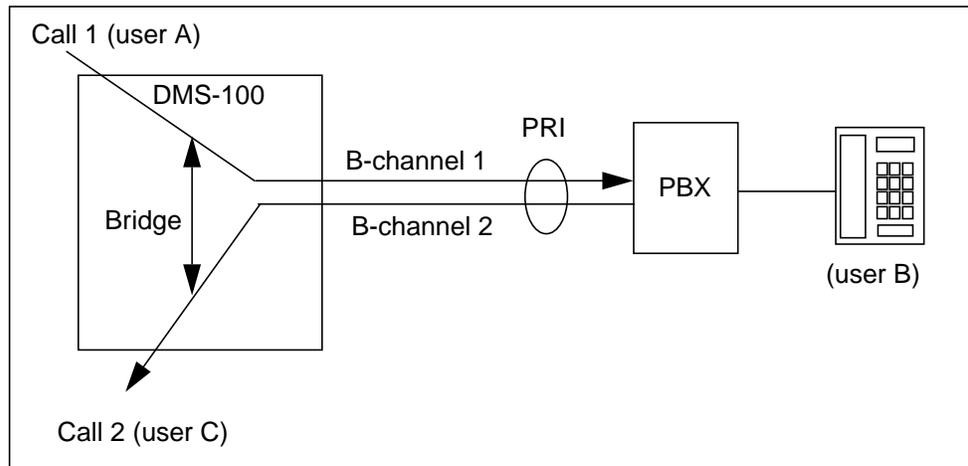

### Translations table flow

The PRI Two B-channel Transfer tables are described in the following list:

- Table SVPRIGRP defines serving PRI groups. All PRIs that belong to the same serving PRI Group are viewed as terminating at the same destination. When requesting TBCT across D-channels, (that is, across PRI interfaces),

---

## PRI Two B-channel Transfer (continued)

---

the two PRIs must be in the same service PRI group for the request to be accepted. Through table SCPRIGRP, the operating company can create up to 1022 serving PRI groups. A serving PRI group is identified through the key PGRPID in table SVPRIGRP. This key is referenced in table LTDEF to identify logical terminal identifiers (LTID) that belong to a serving PRI group.

- Table LTDEF defines the service profile of an ISDN LTID. The key to this table is an LTID. An LTID consists of a logical terminal group (LTGRP) from table LTGRP and a logical terminal number (LTNUM) in a range of 1 to 1022. This table must be datafilled to provision PRI and BRI services. The type of service requested is distinguished by the LTCLASS field, for example, BRAKS, BRAFS, PRA, and BRAMFT. Based on the type of service, logical terminal specific options can be datafilled against a specific LTID. The PGR;PID field in table LTDEF associates the LTID with a serving PRI group.
- Table LTDATA (Logical terminal data) stores service-related data associated with the LTID (field LTDKEY), which is the key to this table. Field LTDKEY consists of three parts: the logical terminal group (subfield LTGRP), logical terminal number (subfield LTNUM), and logical terminal data type (subfield DATATYPE). The TBCT option must be datafilled in table LTDATA for the request to be accepted. For TBCT across D-channels, TBCT must be datafilled on both PRIs involved in the transfer.
- Table BCCOMPAT (bearer capability compatibility) defines the bearer capability (BC) pairs that are compatible. For example, a terminal with a 300-baud modem BC can communicate with a terminal with a 300- to 1200-baud modem BC. TBCT calls are accepted only if the two calls involved in the transfer have compatible bearer capabilities.

The PRI Two B-channel Transfer translation process is shown in the following flowchart:

**PRI Two B-channel Transfer** (continued)

**Table flow for PRI Two B-channel Transfer**

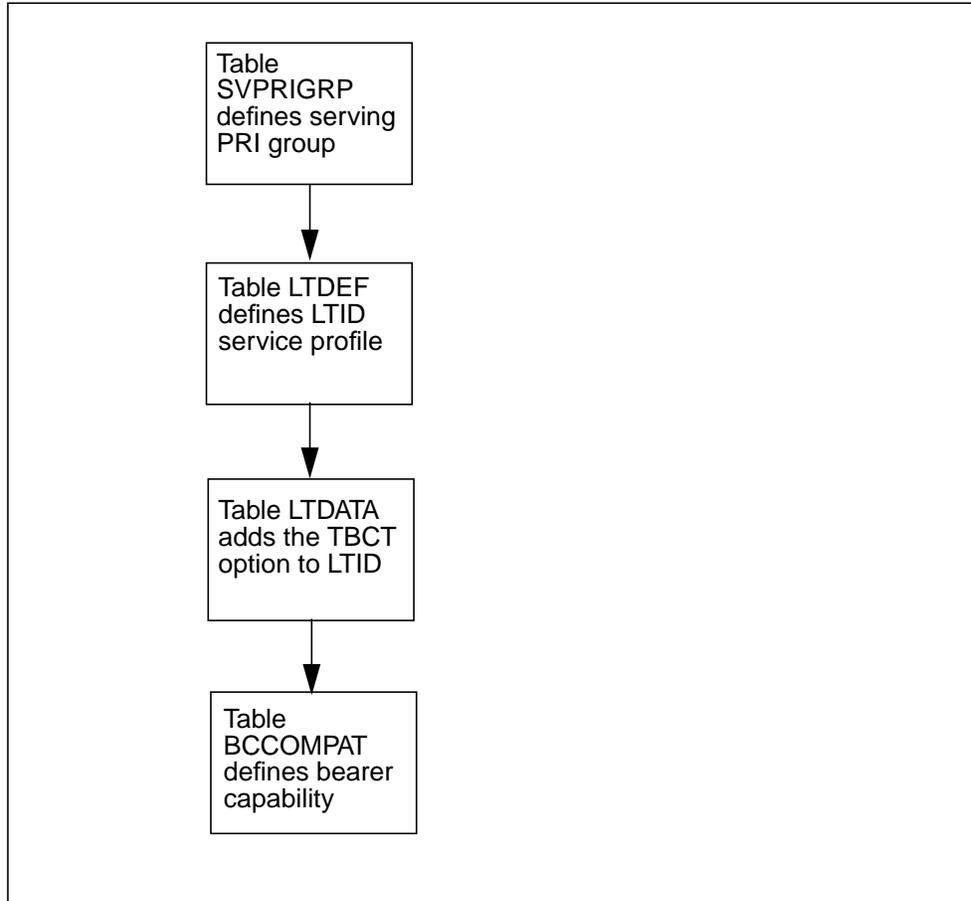

The following table provides examples of data in the tables used in the flowchart.

**Example of data in tables used for PRI Two B-channel Transfer**

Table	Example data
SVPRIGRP	PRI_TO_MTRL 2 (ISDN 381) (ISDN 383) \$
LTDEF	ISDN 381 B PRA 10 10 5 5 NIPRI NI2V1 NIL (PGRPID PRI_TO_MTRL) \$ ISDN 383 B PRA 10 10 5 5 NIPRI NI2V1 NIL \$
LTDATA	ISDN 381 SEERV SERV Y Y ALWAYS ALWAYS (TBCT (NTC ON) \$) \$ ISDN 383 SERV SERV Y Y ALWAYS ALWAYS (TBCT (NTC OFF) \$) \$
BCCOMPAT	SPEECH 3_1KHZ 3_1KHZ SPEECH

---

## PRI Two B-channel Transfer (continued)

---

### Limitations and restrictions

The following limitations and restrictions apply to PRI Two B-channel Transfer:

- The calls to be transferred through TBCT must use the public E.164 dial plan as the NPI and LOCAL or NATIONAL as the type of number (TON) in the Called Party Number information element (IE).
- The SSP rejects TBCT requests for agents with the following terminating characteristics:
  - terminating MADN calls that are not answered due to possible trace conditions during answer by a MADN member
  - terminating multiparty line calls that are not answered due to possible trace conditions during answer by a multiparty member
  - attendant console due to limited support on PRI and AIN

- TBCT does not provide any interface to the operating company operations
- The following limitations and restrictions apply to PRI Two B-channel Transfer:

The calls to be transferred through TBCT must use the public E.164 dial plan as the NPI and LOCAL or NATIONAL as the type of number (TON) in the Called Party Number information element (IE).

The SSP rejects TBCT requests for agents with the following terminating characteristics:

terminating MADN calls that are not answered due to possible trace conditions during answer by a MADN member

terminating multiparty line calls that are not answered due to possible trace conditions during answer by a multiparty member

TBCT does not provide any interface to the operating company operations, administration, and maintenance (OAM) systems other than the standard table editor.

- Transfer request is limited to the local SSP, which is the SSP that first receives the TBCT request. The system does not tandem the request to the next office.
- Interactions with ISUP CCTO are not supported. ISUP CCTO is used to release ISUP trunks that are made redundant as a result of the bridging of the two users. For example, if users A and B were on one DMS switch and the controller on another DMS switch, the system does not release the ISUP trunks connecting the two switches.



## **PRI Two B-channel Transfer** (continued)

---

- The functionality provided by this feature is limited to the North American DMS-100 switch and is supported on standard DMS-100 NI-2 peripherals ISDN DTC and ISDN LTC.
- The SSP processes the first facility information element (FIE) in a facility message (with multiple FIEs) and ignores the rest. TBCT must be in the FIE for the SSP to process it. This characteristic indicates that no facility message with Return Result is sent to the controller if TBCT is not in the first FIE.
- The SSP does not check duplicate invoke IDs.
- The invoke ID length is restricted to one byte.
- Feature interactions are limited to those documented in this section. All other feature interactions are not validated and therefore not supported.
- TBCT does not support the transfer of AIN primer calls.
- There are some conditions where the DMS switch cannot distinguish between a linkid that corresponds to a valid call that the system is currently disconnecting and an invalid linkid. In this situation, the system returns Error Value #07 "Invalid call state".

*Note:* If the system denies TBCT, there is no impact to the subscriber. The calls remain in the same state as before the TBCT request, and the system does not release the B-channels. If a TBCT request has the returned error code "Invalid call state" this code implies that the controller can again attempt TBCT at a later time.

The following limitations and restrictions apply to PRI Two B-channel Transfer, Phase 2:

- The number of PRIs in a serving PRI group is limited to 400.
- The number of serving PRI groups is limited to 1022.
- For TBCT notification to controller functionality, the maximum number of calltags in the DMS switch is 1000 and is unique to the DMS switch.
- The PRI Two B-channel Transfer Phase 2 feature supports the same set of feature interactions as AR2401.

### **Activation/deactivation by the end user**

PRI Two B-channel Transfer requires activation by the controller, depending on the type of equipment in use and the office procedures practiced by the controller. The facility message with the embedded Invoke Component is the trigger for the TBCT. The controller's equipment can be provisioned to automatically initiate TBCT, or manual intervention can be required. The

---

## PRI Two B-channel Transfer (continued)

---

precise nature of manual intervention depends on the equipment in use. The PRI interface need the TBCT option.

### Datafilling sequence

The following table lists the tables that require data to implement PRI Two B-channel Transfer. the tables are listed in the order in which they are to be datafilled.

#### Data tables required for PRI Two B-channel Transfer

Table	Purpose of table
SVPRIGRP	Table SVPRIGRP defines the serving PRI groups for ISDN logical terminals (LTID) in table LTDEF.
LTDEF	Table LTDEF defines the service profile of an LTID.
LTDATA	Table LTDATA stores service-related data associated with the LTID (field LTKEY), which is the key to this table.
BCCOMPAT	Table BCCOMPAT defines the bearer capability (BC) pairs that are compatible.

### Billing

PRI Two B-channel Transfer does not affect billing. Billing continues as if the calls never transferred.

### Station Message Detail Recording

PRI Two B-channel Transfer does not affect Station Message Detail Recording.

### Datafilling office parameters

PRI Two B-channel Transfer does not affect office parameters.

**PRI Two B-channel Transfer** (continued)

**Datafilling table SVPRIGRP**

The following table shows the data required for table SVPRIGRP.

**Datafilling table SVPRIGRP**

Field	Subfield	Entry	Explanation and action
PGRPID		alphanumeric (up to 16 characters)	This field is the key that identifies the serving PRI group.
NUMMEM		0–400 (automatic update)	This field records the number of LTIDs that are associated with the serving PRI group. the system automatically updates NUMMEM whenever the operating company adds, modifies, or deletes an LTID associated with the group. LTIDs are recorded in table LTDEF.
MEMBERS		a vector of LTIDs (automatic update)	This field records the PRI identifiers that are associated with the serving PRI group. the system automatically updates MEMBERS whenever the operating company adds, modifies, or deletes an LTID associated with the group. LTIDs are recorded in table LTDEF.

**Datafill example for table SVPRIGRP**

The following example shows sample data for table SVPRIGRP.

**MAP display example of table SVPRIGRP**

PGRPID	NUMMEM	MEMBERS
PRI_TO_MTRL	2	(ISDN 381) (ISDN 383) \$

---

**PRI Two B-channel Transfer** (continued)

---

**Error messages for table SVPRIGRP**

The following error messages apply to table SVPRIGRP for PRI Two B-channel Transfer.

**Error messages for table SVPRIGRP**

Error message	Explanation and action
Member list data discarded.	Any non-zero data for NUMMEM and MEMBERS is discarded on tuple addition, defaulting to values of 0 and \$ respectively. This message appears when NUMMEM is not zero.
NIL is an invalid key.	NIL PGRPID is not allowed as a key to table SVPRIGRP.
Table is full.	Table SVPRIGRP has a limit of 1022 tuples. this error message appears when you attempt to add more than 1022 tuples.
Tuple is being referenced by table LTDEF.	A tuple in table SVPRIGRP cannot be deleted unless the number of MEMBEERS in the serving PRI group (NUMMEM) is zero. You can only delete the tuple if there are no PRI interfaces assigned to it.
Use table LTDEF to add or remove members.	Both fields NUMMEM and MEMBERS are read-only fields and automatically reflect the current mapping as assigned in table LTDEF. This message appears whenever you try to add a tuple to table SVPRIGRP. Modification to tuples in table SVPRIGRP is not allowed.

---

**PRI Two B-channel Transfer** (continued)
 

---

**Datafilling table LTDEF**

the following table shows the data specific to PRI Two B-channel Transfer for table LTDEF. Only those fields that apply directly to PRI Two B-channel Transfer are shown.

**Datafilling table LTDEF**

Field	Subfield	Entry	Explanation and action
CLASSREF			Class reference. this field consists of subfield LTCLASS
	LTCLASS	PRA	Logical terminal class. this field identifies the set of services that are allowed for this LTID. PRA allows primary rate access services. Datafill subfield VARIANT if LTCLASS equals PRA.
	VARIANT	NIPRI	Variant type. This field defines the PRI protocol for the LTID. NIPRI defines the protocol as NI-2 PRI.
OPTION			Option. Subfield PGRPID applies when LTCLASS is PRA.
	PGRPID	alphanumeric (up to 16 characters), NIL	PRI group identifier. Enter PGRPID followed by the name of the serving PRI group, which is the key to table SVPRIGRP. This name must first be datafilled in table in table SVPRIGRP.  The default for this field is NIL. If the value is NIL, PGRPID does not appear in the options list fro the tuple.  This field is only required if VARIANT = NIPRI.

**Datafill example of table LTDEF**

The following example shows sample data in table LTDEF.

---

## PRI Two B-channel Transfer (continued)

---

### MAP display example of table LTDEF

LTKEY	LTAP	PGRPID	CLASSREF
ISDN 381	B	PRA 10 10 5 5	NIPRI NI2V1 NIL (PGRPID PRI_TO_MTL) \$
ISDN 383	B	PRA 10 10 5 5	NIPRI NI2V1 NIL \$

### Error messages for table LTDEF

the following error messages apply to table LTDEF for PRI Two B-channel Transfer.

#### Error messages for table LTDEF

Error message	Explanation and action
Cannot change VARIANT: TBCT provisioned on LTID in Table LTDATA. Delete TBCT from the tuple in LTDATA FIRST.	You cannot change the protocol variant while the LTID is provisioned for TBCT in table LTDATA. Remove the option from the LTID through table LTDATA.
Data store corruption encountered.	A data store corruption has occurred.
PGRPID option set to NIL.	This error message displays if you set the PGRPID to NIL. If you omit the PGRPID option, this message does not display.
PGRPID supported for NIPRI variant only.	This error message displays if you try to add PGRPID to an LTID with a VARIANT that is not NIPRI.
Serving PRI group is full.	The number of members in the group has exceeded 400.
Too many PGRPID options.	this error message displays if you enter the PGRPID option more than once.

**PRI Two B-channel Transfer** (continued)

**Datafilling table LTDATA**

The following table shows the data specific to PRI Two B-channel Transfer for able LTDATA. Only those fields that apply directly to PRI Two B-channel Transfer are shown.

**Datafilling table LTDATA**

Field	Subfield	Entry	Explanation and action
LTDRSLT			Logical terminal result. This field consists of subfield DATATYPE.
	DATATYPE	SERV	Logical terminal data type. This field consists of subfield OPTION.
	OPTION	TBCT	The presence of TBCT in the OPTION vector indicates TBCT is provisioned and available.  The following logical terminal data must be in table LTDEF: <ul style="list-style-type: none"> <li>• The logical terminal class (LTCLASS) must be PRA.</li> <li>• The protocol variant (VARAIANT) corresponding to the logical terminal must be NIPRI.</li> </ul>
	PARM	NTC	Enter to identify subscription to the Notification to Controller feature. the STATUS subfield indicates if the subscription is ON or OFF. NTC is the only value for this subfield.
	STATUS	ON, OFF	Enter ON to turn on the notification to controller functionality (AF7322). enter OFF to turn off this functionality. the default is ON.

**Datafill example for table LTDATA.**

The following example shows sample data for table LTDATA.

**MAP display example for table LTDATA**

```

LTDKEY LTDRSLT
-----
ISDN 381 SERV SERV Y Y ALWAYS ALWAYS (TBCT (NTC OFF)) $
ISDN 383 SEEV SERV Y Y ALWAYS ALWAYS (TBCT (NTC ON)) $
    
```

---

**PRI Two B-channel Transfer** (end)

---

**Error messages for table LTDATA**

The following error messages apply to table LTDATA for PRI Two B-channel Transfer.

**Error messages for table LTDATA**

Error message	Explanation and action
TBCT OPTION IS ONLY SUPPORTED FOR VARIANT NIPRI.	You cannot datafill the TBCT option if the variant for the LTID in table LTDEF has a value other than NIPRI. In table LTDEF, datafill LTCLASS = PRA and VARIANT = NIPRI before datafilling the TBCT option in table LTDATA.

**Translation verification tools**

PRI Two B-channel Transfer does not use translation verification tools.

**SERVORD**

PRI Two B-channel Transfer does not use SERVORD.



## **PRI with Semipermanent Packet**

---

### **Ordering codes**

Functional group ordering code: NI000034

Functionality ordering code: NI000034

### **Release applicability**

NA011 and up

PRI with Semipermanent Packet was introduced in NA011.

### **Prerequisites**

PRI with Semipermanent Packet has no prerequisites.

### **Description**

The PRI with Semipermanent Packet (Provisioning and Query Tools) feature provides X.25 primary rate B-channel packet services to meet National ISDN-2 requirements. This feature allows operating company personnel to assign a B-channel on the PRI T1 link from the customer premises equipment (CPE) to the packet handler. This feature specifies the capabilities to support a semipermanent (nailed up) X.25 packet connection on PRI. The existing X.25 services on basic rate interface (BRI) are available on PRI.

### **Operation**

This feature addresses the requirements of those individuals who work from home and need their computers continuously connected to the packet network. The following changes occur in the provisioning and query tools to allow continuous connectivity.

#### **Provisioning**

The DS-1 channels that carry X.25 packet services are defined as trunks for identification and maintenance purposes. The DS-1 channels that carry X.25 packet services are viewed as lines for routing and translation purposes. PRI packet services has a line service profile (identified by a logical terminal identifier [LTID] plus an associated directory number [DN]) and a trunk maintenance profile (identified by a common language location identifier [CLLI]). The packet PRI trunks are similar to X.75 trunk in terms of internal connectivity.

The following diagram shows the tables that datafill for PRI with Semipermanent Packet.

**PRI with Semipermanent Packet** (continued)

**Table flow for PRI with Semipermanent Packet**

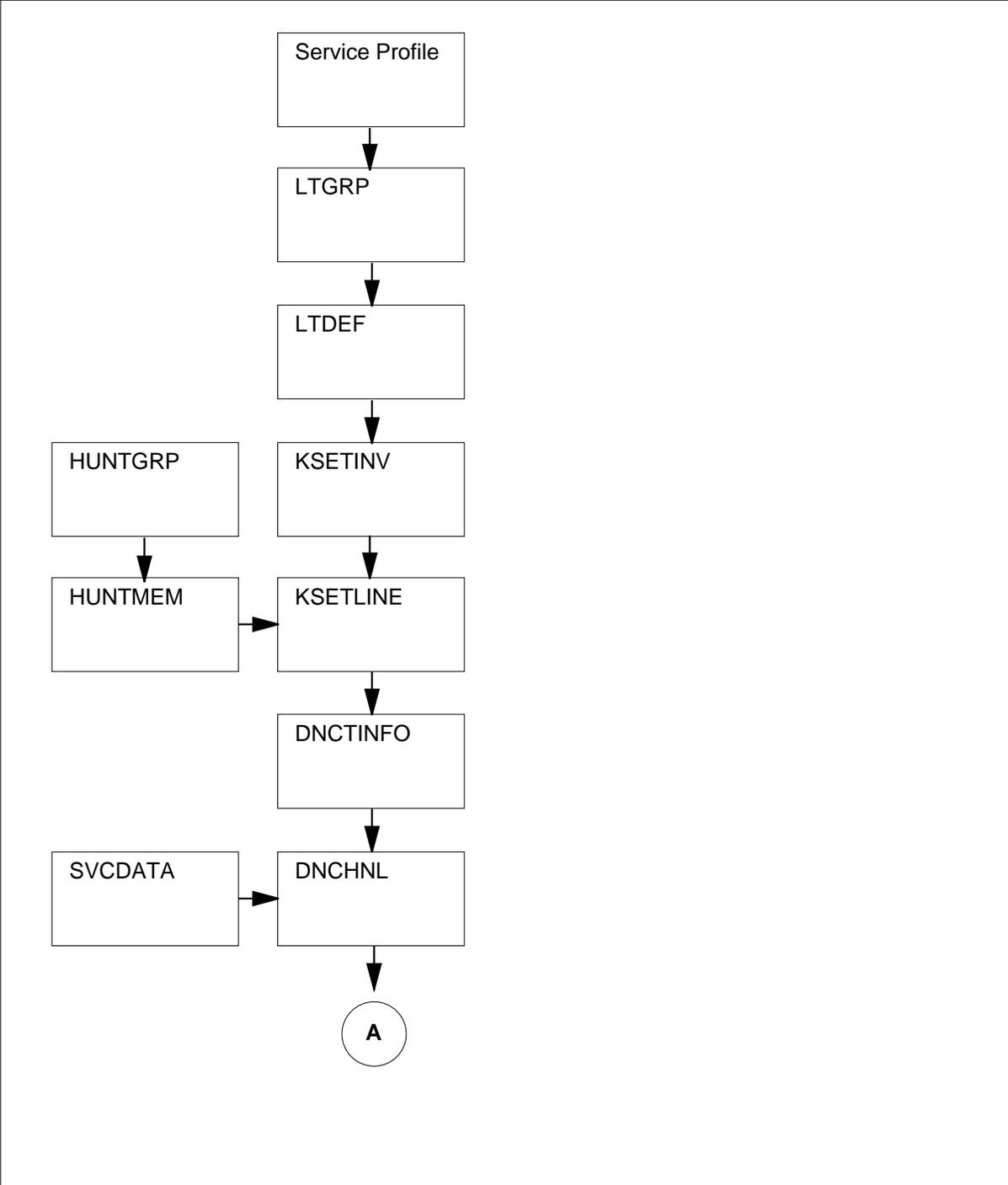

## PRI with Semipermanent Packet (continued)

Table flow for PRI with Semipermanent Packet (continued)

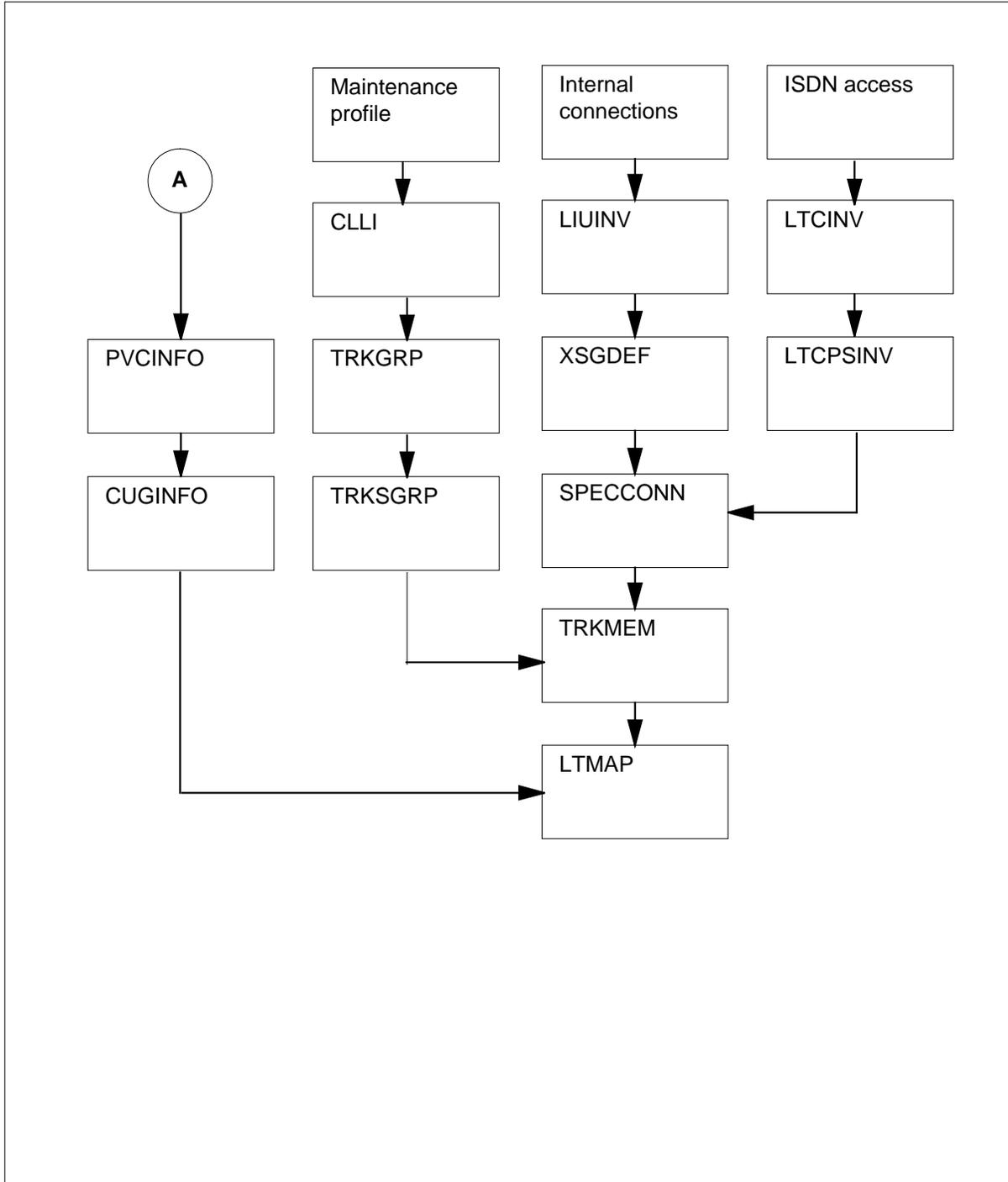

---

## PRI with Semipermanent Packet (continued)

---

### Example provisioning of a DS-0 channel as PRI with Semipermanent Packet

The following tables show example provisioning of a DS-0 channel as PRI with Semipermanent Packet.

#### Precondition datafill

An example provisioning of a DS-0 channel (LTC 0 6 23) as PRI with Semipermanent Packet is shown in table "Datafill example with PRI with Semipermanent Packet." For this example datafill to be valid, the datafill in the table assumes the PRA interface is provisioned as shown in table "Example of precondition datafill."

#### Example of precondition datafill for PRI with Semipermanent Packet

Datafill table	Example data
LTGRP	PRAOG 9 (SAPI16) \$
LTDEF	PRAOG 18 B PRA 6 6 0 6 NIPRI NI2V1 NIL \$
LTCPSINV	LTC 0 N (0 DS30A ) (1 DS30A ) (2 DS30A ) (3 DS30A ) (4 DS30A ) (5 DS30A ) (6 DS1PRA ESFB8ZS N 1 NIL) (7 DS1PRA ESFB8ZS N 1 NIL) (8 DS1PRA ESFB8ZS N 1 NIL) (9 DS1PRA ESFB8ZS N 1 NIL) (10 NILTYPE) (11 NILTYPE) (12 DS1PRA ESFB8ZS N 1 NIL) (13 DS1PRA EWSFBZS N 1 NIL) (14 NILTYPE ) (15 DCH ) (16 NILTYPE ) (17 DCH ) (18 NILTYPE ) (19 DCH ) \$
CLLI	PRIOG 55 22 LOOP_AROUND_ISDN_PRI
TRKGRP	PRIOG PRA 0 PRAC NCRT ASEQ N \$ \$
TRKSGRP	PRIOG 0 DS1SIG ISDN 20 20 87Q931 2 N STAND NETWORK PT_PT USER N UNEQ 255 N DEFAULT LTC 0 6 24 64K HDLC \$ \$
LTMAP	PRAOG 18 CLLI PRIOG (TEI) \$
TRKMEM	PRIOG 0 0 LTC 0 6 2 PRIOG 1 0 LTC 0 6 3PRIOG 2 0 LTC 0 6 4 PRIOG 3 0 LTC 0 6 5 PRIOG 4 0 LTC 0 6 6 PRIOG 5 0 LTC 0 6 7 PRIOG 6 0 LTC 0 6 8 PRIOG 7 0 LTC 0 6 9 PRIOG 8 0 LTC 0 6 10 PRIOG 9 0 LTC 0 6 11PRIOG 10 0 LTC 0 6 12PRIOG 11 0 LTC 0 6 13 PRIOG 12 0 LTC 0 6 14PRIOG 13 0 LTC 0 6 15PRIOG 14 0 LTC 0 6 16PRIOG 15 0 LTC 0 6 17PRIOG 16 0 LTC 0 6 18PRIOG 17 0 LTC 0 6 19PRIOG 18 0 LTC 0 6 20PRIOG 19 0 LTC 0 6 21PRIOG 20 0 LTC 0 6 22
<b>Note:</b> The DS-0 LTC 0 6 23 is not in use by voice PRI.	

## PRI with Semipermanent Packet (continued)

### Datafill example for PRI with Semipermanent Packet

The following table lists the datafill content used in the "Tableflow for PRI with Semipermanent Packet" flowchart. The DS-0 channel (LTC 0 6 23) is provisioned as PRI with Semipermanent Packet by datafilling the following tables.

#### DATAFILL EXAMPLE OF PRI with Semipermanent Packet

Datafill table	Example data
LTGRP	PRAPKT 8 (SAPI16) \$
LTDEF	PRAPKT 1 PB BRAFS \$
KSETINV	PRAPKT 1 ISDNKSET 12 \$
KSETLINE	PRAPKT 1 1 DN N 5551001 LONS634 0 0 613 \$ BRI PMD
DNCTINFO	6135551001 PMD PMD (NUI N) (FSA N) (RCA N) (ICS N) (CUGS N) (TCN N) (FCPN N) (OCB N) (LCP N) (RPOAB N) \$
DNCHNL	6135551001 B B (LLFSQ MOD8) (LLWS 7) 9T1 20) 9T2 2) (T3 5) (N2 3) (LCA (SLCN 1) (NPVC 0) (NOWI 0) (NNRC 1) (NOWO 0) \$) (PLSQ MOD8) (NDWS N) (NDPS N) (DTCA N) \$
XSGDEF	100 MS 21 0 1 30 Y
LTCPSINV	LTC 0 N (0 DS30A ) (1 DS30A ) (2 DS30A ) (3 DS30A ) (4 DS30A ) (5 DS30A ) (6 DS1PRA ESFB8ZS N 1 NIL) (7 DS1PRA ESFB8ZS N 1 NIL) (8 DS1PRA ESFB8ZS N 1 NIL) (9 DS1PRA ESFB8ZS N 1 NIL) (10 NILTYPE) (11 NILTYPE) (12 DS1PRA ESFB8ZS N 1 NIL) (13 DS1PRA EWSFBZS N 1 NIL) (14 NILTYPE ) (15 DCH ) (16 NILTYPE ) (17 DCH ) (18 NILTYPE ) (19 DCH ) \$
SPECCONN	XSGCHNL 100 (9) \$ DS1 LTC 0 6 23 CON ACTIVE
CLLI	PKTPRI 56 5 Packet_on_PRI_CLLI
TRKGRP	PKTPRI PRA 0 PRAC NCRT ASEQ N \$ \$
TRKSGRP	PKTPRI 0 DS1SIG X25
TRKMEM	PKTPRI 1 0 LTC 0 23
LTMAP	PRAPKT 1 CLLIPKTPRI (MEM 1) \$
<b>Note:</b> This datafill assumes the PRA interface is provisioned as shown in the Precondition Datafill for PRI with Semipermanent Packet table.	

---

## PRI with Semipermanent Packet (continued)

---

### Service profile

For this feature, the service profile for PRI is the same as the service profile for BRI with one exception. The default value for the Default Throughput Class Area (DTCA) for this feature is 9.6 kbit/s. The default value for BRI packet service is 64 kbit/s.

The following tables are included in the service profile:

- LTGRP
- LTDEF
- KSETINV
- KSETLINE
- DNCTINFO
- DNCHNL
- PVCINFO
- CUGINFO

If the customer does not subscribe to DTCA in table DNCHNL, then the DMS switch assigns 64 kbit/s as the default value. If the logical terminal identifier (LTID) relating to the directory number (DN) maps to the PRI interface, the default value changes to 9.6 kbit/s.

### Maintenance profile

The trunk tables (CLLI, TRKGRP, TRKSGRP) define the maintenance profile for this feature on PRI.

- Table CLLI defines a common language name for the PRI with Semipermanent Packet trunks.
- Table TRKGRP defines a group of PRI with Semipermanent Packet trunks. The group type for these trunks is PRA.
- Table TRKSGRP for PRI with Semipermanent Packet is distinguished from the voice PRI subgroup by having a different signaling type. The signaling type for PRI with Semipermanent Packet subgroup is X.25.

Use the PRA group type in table TRKGRP and use the X.25 signaling type for this feature. Use CLLI with type X.25 subgroup only for packet services on PRI.

- If a PRA CLLI is present with one of its two subgroups with signaling type ISDN, then the other subgroup cannot be signaling type X.25.
- If a PRA CLLI is present with one of its two subgroups having signaling type X.25, then the other subgroup cannot be signaling type ISDN.

## **PRI with Semipermanent Packet** (continued)

---

The result is that a new CLLI must be defined for PRI with Semipermanent Packet. This CLLI is used exclusively for this feature.

### **ISDN PRI access**

The access definition for this feature is identical to the access definition for voice PRI. Operating company personnel use tables LTCINV and LTCPSINV to define access definitions.

### **Internal connections**

This feature uses table SPECCONN to make the internal connections between an XSG channel and a DS-0 endpoint.

### **Mapping a maintenance profile to a DS-0 channel**

Tables CLLI, TRKGRP, and TRKSGRP define the maintenance profile. The DMS switch uses table TRKMEM to map a member of the trunk group to a DS-0 channel.

### **Mapping a service profile to a maintenance profile**

The LTID identifies the service profile for this feature. The CLLI and MEMBER identify the maintenance profile. The DMS switch uses table LTMAP to map the service profile to the maintenance profile. To map an LTID to CLLI and MEMBER, specify the member when the map type is CLLI using option MEM in table LTMAP.

## **Query tools**

Query tools display information about ISDN services, such as logical terminals (LT), DN, and line equipment. Use the QPHF and QLT modified commands to query this feature on PRI.

### **QPHF**

Use the non-menu QPHF (query packet handler function) command to display provisioning information about all objects included in the service. (Objects include DN, channels, and links.) The following additional information displays with the QPHF commands:

- The QPHF LTID command shows that the LT is on an X.25 B link and is assigned to a PRI B-channel. The CLLI and MEMBER also display.
- The QPHF XSG command shows that the channel on the XSG is a PRI channel with X.25 service.
- The QPHF CHNL command shows that the channel type is PRI.
- The QPHF CLLI command shows a DN instead of a CLLI and MEMBER. The display also shows X.25 PRI for the channel type and X.25 B for the link type.

---

## PRI with Semipermanent Packet (continued)

---

- The QPHF DN command shows X.25 PRI for the channel type.
- If the operating company personnel use the QPHF X.75 command to enter an X.25 PRI CLLI, the following error message displays:

```
THIS IS A PRI CLLI. USE QPHF CLLI.
```

### QLT

Use the non-menu QLT (query logical terminal) command to display information about an LTID. This feature on PRI includes the following information:

- all DNs assigned to the keys on an LTID
- access privileges and the LTCLASS of the LTID
- DS-0 endpoint Notice that the DS-0 endpoint displays for PRI instead of a LEN, which displays for BRI.

### Translations table flow

PRI with Semipermanent Packet does not affect translations table flow.

### Limitations and restrictions

The following paragraphs describe the interactions between PRI with Semipermanent Packet (Provisioning and Query Tools) and other functionalities.

- The feature does not support the SERVORD SLT ATT and SLT DFT commands.
- The DMS switch cannot map PKT PRI LTID to the 24th channel on a DS-1.
- This feature on PRI works only on ISDN DTCI and LTCI.

### Interactions

The following paragraphs describe the interactions between PRI with Semipermanent Packet (Provisioning and Query Tools) and other functionalities.

- This feature interacts with AF7625, PRI with Semipermanent B Packet (Maintenance & CallP).
- This feature interacts with AF6777, Shared DN.
- This feature can share a DN with BRI VI and CMD. PKT BRI and PKT PRI can reside in the same hunt group.



## **PRI with Semipermanent Packet** (continued)

---

### **Activation/deactivation by the end user**

PRI with Semipermanent Packet requires no activation or deactivation by the end user.

### **Billing**

PRI with Semipermanent Packet does not generate billing records or changes.

### **Station Message Detail Recording**

PRI with Semipermanent Packet does not affect Station Message Detail Recording.

### **Datafilling office parameters**

PRI with Semipermanent Packet does not affect office parameters.

### **Datafill sequence**

The PRI with Semipermanent Packet feature requires all the tables listed in the table flow diagram (Table flow for PRI with Semipermanent Packet) to datafill to implement this feature. However, only the following tables are modified to accommodate this feature. Tables must fill with data in the order listed in the table flow diagram.

#### **Datafill tables required for PRI with Semipermanent Packet**

<b>Tables</b>	<b>Purpose of table</b>
TRKSGRP	Trunk Subgroup. This table defines the attributes of the D-channel in each PRI trunk group.
TRKMEM	Trunk Member. This table defines the attributes of the B-channels in each trunk group.
LTMAP	Logical Terminal Mapping. This table associates the LTID of the PRI trunk with the trunk group CLI.

---

## PRI with Semipermanent Packet (continued)

---

### Datafilling table TRKSGRP

The following table shows the datafill specific to PRI with Semipermanent Packet for table TRKSGRP. Only those fields that apply directly to PRI with Semipermanent Packet are shown.

#### Datafilling table TRKSGRP

Field	Subfield	Entry	Explanation and action
SGRPVAR		X25	The signaling type X25 distinguishes PRI with Semipermanent Packet on PRI CLLI from other types of CLLIs.

### Datafill example for table TRKSGRP

The following example shows sample datafill for table TRKSGRP.

#### MAP display example for table TRKSGRP

```

SGRPKEY  CARDCODE  SGRPVAR
-----
PKTPRI 0  DS1SIG   X25

```

## PRI with Semipermanent Packet (continued)

---

### Error messages for table TRKSGRP

The following error messages apply to table TRKSGRP.

#### Error messages for table TRKSGRP (Sheet 1 of 2)

Message	Description
Cannot mix signaling types in subgroups if ISDN is involved	<p data-bbox="938 531 1403 657">For PRI with Semipermanent Packet, use signaling type X25 for both subgroups 0 and 1. This error message displays under the following conditions:</p> <p data-bbox="938 678 1403 831">The trunk group type is PRA and the signaling type is X25 for subgroup 0. During datafill in table TRKSGRP, if the signaling type ISDN datafills subgroup 1, then this error message displays.</p> <p data-bbox="938 863 1403 1016">The trunk group type is PRA and the signaling type is ISDN for subgroup 0. During datafill in table TRKSGRP, if the signaling type X25 datafills subgroup 1, then the error message displays.</p> <p data-bbox="938 1047 1403 1234">For X25 signaling type, use both subgroups 0 and 1. Use a tuple in the TRKSGRP table with signaling type X25 for the same CLLI and for the other subgroup, provided the first subgroup has X25 signaling.</p>

---

## PRI with Semipermanent Packet (continued)

---

### Error messages for table TRKSGRP (Sheet 2 of 2)

Message	Description
SELSEQ must be CWCTH or CCWCTH for X75 trunks	<p>This error message displays when table TRKSGRP datafills for PRI with Semipermanent Packet and for X75 trunks. In table TRKGRP, the datafill for PKTPRI CLLI contains an incorrect entry for SELSEQ. For this feature, the SELSEQ for PKTPRI CLLI is CWCTH or CCWCTH because the functionality is similar to X75 trunks.</p> <p>Go to table TRKGRP and delete the tuple with key as PKTPRI CLLI. Add an entry in table TRKGRP with PKTPRI CLLI and with SELSEQ as either CWCTH or CCWCTH. Then datafill table TRKSGRP.</p>
Cardcode must be DS1SIG on Packet PRI trunks	<p>This error message displays if the cardcode value in table TRKSGRP is not DS1SIG for PRI with Semipermanent Packet on PRI trunks.</p> <p>For this feature, use cardcode DS1SIG with signaling type X25.</p>

### Datafilling table TRKMEM

The datafill for table TRKMEM does not change with the PRI with Semipermanent Packet feature.

---

**PRI with Semipermanent Packet** (continued)
 

---

**Error messages for table TRKMEM**

The following error messages apply to table TRKMEM.

**Error message for table TRKMEM**

Error message	Explanation and action
DS-0 must be nailed up in SPECCONN for X25 PRA	<p>While tables CLLI, TRKGRP, and TRKSGRP datafill, table SPECCONN does not datafill. When table TRKMEM datafills, table TRKMEM searches for a DS-0 connection on table SPECCONN. If the DS-0 connection is absent on table SPECCONN, this error message displays.</p> <p>Datafill table SPECCONN before table TRKMEM.</p>
Delete the LTMAP entry first	<p>All the tables datafill for PKTPRI. This error message displays when operating company personnel try to change or delete a tuple in table TRKMEM.</p> <p>Delete the tuple in table LTMAP, then try to change the tuple in table TRKMEM for the corresponding DS-0.</p>
Cannot use time slot 24 on DS-0 for Packet on PRI	<p>Timeslot 24 is reserved for the D-channel for the ISDN PRI trunk. This error message displays if the operating company personnel try to use timeslot 24.</p> <p>Use a timeslot other than 24 in table TRKMEM.</p>

---

## PRI with Semipermanent Packet (continued)

---

### Datafilling table LTMAP

The following table shows the datafill specific to PRI with Semipermanent Packet for table LTMAP. Only those fields that apply directly to PRI with Semipermanent Packet are shown.

#### Datafilling table LTMAP

Field	Subfield	Entry	Explanation and action
OPTION		MEM (values 0 to 19)	Member number. This option prompts operating company personnel to enter the member number of the trunk group. Option MEM specifies that the LTID is a packet on PRI LTID. (MEM is only valid for packet on PRI.)

#### Datafill example for table LTMAP

The following example shows sample datafill for table LTMAP.

#### MAP display example for table LTMAP

```
OPTION
-----
PRAPKT 1 CLLI PKTPRI (MEM1)$
```

#### Error messages for table LTMAP

The following error messages apply to table LTMAP.

##### Error message for table LTMAP (Sheet 1 of 3)

Error message	Explanation and action
Only MEM option should be present for Packet on PRI	PRI with Semipermanent Packet LTID supports option MEM only.  Perform the LTMAP datafill with only option MEM present.
The maptype should be CLLI for Packet on PRI LTIDs	This error message displays if MEM option is present in table LTMAP with a map type other than CLLI.  Use CLLI instead of LEN as the datafill for MAP types.

## PRI with Semipermanent Packet (continued)

### Error message for table LTMAP (Sheet 2 of 3)

Error message	Explanation and action
Table TRKMEM should be datafilled before LTMAP	<p>This error message displays if table TRKMEM does not datafill to map the CLLI and MEMBER to DS-0 datafill in SPECCONN.</p> <p>Datafill table TRKMEM for a member other than 24.</p>
The trunk group should be PRA for Packet on PRI trunk	<p>This error message displays if the trunk type is not PRA.</p> <p>Use CLLI. CLLI has a PRA trunk group type.</p>
The signaling type of subgroup should be X25 for Packet on PRI CLLI MEM	<p>This error message displays if the subgroup to which CLLI and member belong, does not have the X25 signaling type.</p> <p>Use Packet on PRI CLLI with an X25 subgroup and member in table LTMAP.</p>
The CLLI & MEMBER are already in use	<p>This error message displays if CLLI and MEMBER already map in table LTMAP.</p> <p>The same CLLI and MEMBER cannot map to another LTID.</p>
The terminal class of the LTID is not BRAFS	<p>This error message displays if the terminal class of an LTID is not basic rate access functional set (BRAFS).</p> <p>The terminal class of an LTID is BRAFS for PRI with Semipermanent Packet.</p>
The access privilege of LTID must be PB	<p>This error message displays if the access privilege of the LTID is not PB.</p> <p>The access privilege of the LTID is PB for PRI with Semipermanent Packet.</p>
The LTID is not datafilled in KSETINV	<p>This error message displays if table KSETINV does not datafill for the correct LTID.</p> <p>The LTID datafills in table KSETINV.</p>

---

**PRI with Semipermanent Packet** (continued)
 

---

**Error message for table LTMAP (Sheet 3 of 3)**

<b>Error message</b>	<b>Explanation and action</b>
Table KSETLINE not datafilled	This error message displays if table KSETLINE does not datafill.  The LTID datafills in table KSETLINE.
Table DNCHNL not datafilled	This error message display if the LTID does not datafill in table DNCHNL.  The LTID datafills in table DNCHNL.
Table DNCTINFO not datafilled	This error message displays if the LTID does not datafill in table DNCTINFO.  The LTID datafills in table DNCTINFO.
Delete the LTMAP entry first	All the tables datafill for PKTPRI. This error message displays when operating company personnel try to change or delete a tuple in table TRKMEM.  Delete the tuple in table LTMAP, Then try to change the tuple in table TRKMEM for the corresponding DS-0.
Cannot use time slot 24 on DS-0 for Packet on PRI	Timeslot 24 is reserved for the D-channel for the ISDN PRI trunk. This error message displays if the operating company personnel try to use timeslot 24.  Use a timeslot other than 24 in table TRKMEM.

**Translation verification tools**

PRI with Semipermanent Packet does not use translation verification tools.

**SERVORD**

PRI with Semipermanent Packet does not use SERVORD.

**User interface**

PRI with Semipermanent Packet affects the user interface.



## PRI with Semipermanent Packet (continued)

### Directories and commands

The following table shows the modified directories that support PRI with Semipermanent Packet. The table also shows the modified commands that support this feature. Access these directories using commands at the CI level.

#### Directories and modified commands required for PRI with Semipermanent Packet (Sheet 1 of 2)

Directory	Command
PROGDIR	<p>QLT</p> <p>The QLT command displays all the information for an LTID. All of this information also displays for PRI with Semipermanent Packet with one exception: the DS0 endpoint displays instead of the LEN.</p>
DMSCI	<p>QPHF</p> <p>The QPHF command displays the provisioning information on all objects (DNs, channels, links) involved in the service for PRI with Semipermanent Packet.</p> <p>QPHF LTID</p> <p>The QPHF LTID command displays all the information for an LTID. The display shows that the logical terminal (LT) is on an X25 B link type and is assigned to a PRI B-channel. The CLLI and MEMBER information also display.</p> <p>QPHF XSG</p> <p>The QPHF XSG command displays all the information for an XSG. The display shows that a channel on the XSG is a PRI channel with X25 service by displaying channel type X25.</p> <p>QPHF CHNL</p> <p>The QPHF CHNL command displays all the information for a channel with one exception: the display shows that the channel type is PRI.</p> <p>QPHF CLLI</p> <p>The QPHF CLLI command displays all the link information (CLLI and MEMBER) with one exception: the display shows a directory number instead of a CLLI and MEMBER. The display also shows X25 PRI as the channel type and X25 B as the link type.</p>

---

**PRI with Semipermanent Packet** (end)

---

**Directories and modified commands required for PRI with Semipermanent Packet (Sheet 2 of 2)**

<b>Directory</b>	<b>Command</b>
	<p data-bbox="446 430 568 462">QPHF DN</p> <p data-bbox="446 472 1388 535">The QPHF DN command displays all the information for a directory number with one exception: the display shows X25 PRI as the channel type.</p> <p data-bbox="446 567 576 598">QPHF X75</p> <p data-bbox="446 609 1388 703">If the operating company personnel enter an X25 PRI CLLI using the QPHF X75 command, the following error message displays: This is a PRI CLLI. Use QPHF CLLI.</p>



---

# Part V

## Operation, administration, and maintenance

---

Part V: “Operation, administration, and maintenance” contains the following chapters:

- Preventive maintenance strategies
- Logs
- Operational measurements
- Advanced troubleshooting procedures ii
- User interface
- Trouble isolation and correction methods
- Troubleshooting chart
- Cause values
- Troubleshooting example



---

## 7 Preventive maintenance strategies

---

This chapter contains an summary of preventive maintenance plans, a description of the processes included, and references to additional information. The information helps maintenance staff to identify less-than-optimal operating conditions before they become alarm-generating conditions.

### Overall preventive maintenance

Preventive maintenance consists of performing routine tests, and monitoring equipment and circuits to prevent service degradation. By monitoring the performance of the switch, maintenance personnel can identify non-optimal operating conditions and take measures to restore optimal operating conditions. For example, maintaining a low bit error ratio.

An effective preventive maintenance strategy uses some or all of the following processes:

- maintenance manager's morning report (AMREP)
- Switch Performance Monitoring System (SPMS)
- routine exercise (REx) testing
- network maintenance
- focused maintenance
- operational measurements (OM)
- routine maintenance

These maintenance processes are applied to the following ISDN PRI components:

- exchange termination (ET)
- ISDN signaling and trunks

The maintenance processes also include the following DMS-100 overhead activities:

- network and peripheral module (PM) integrity parity maintenance
- DS-1 carrier maintenance
- TTP functions
- routine maintenance (BERP, NETFAB)

### **Maintenance manager's morning report**

The maintenance manager's morning report (AMREP) is a switch management tool (software package NTXJ35AA [Maintenance Manager's Report]) that provides a 24-h summary of performance, administrative, and maintenance information about the DMS-100 switch. The report, output and printed as a DMS-100 log report, generates automatically at a scheduled time or on request from a MAP terminal. The report contains two parts:

- DMS-100 switch performance
- scheduled test results

The report provides a summary of the following key maintenance and operations indicators:

- switch performance information including
  - SPMS indicators
  - call processing performance
  - CPU occupancy
  - network performance
  - software performance
  - OM threshold log count
  - PM switch-of-activity (SWACT) information
- scheduled test results, including scheduled trunk maintenance using automatic trunk testing (ATT)
- switch operations including
  - image dump results
  - patch summary
  - outage indicators
  - table data integrity check
  - unscheduled PM REx test

## Switch Performance Monitoring System

The SPMS analyzes OMs to provide a summary of switch performance. The summary is a series of numeric indexes with values between 0 and 100. SPMS indexes are different from OMs because SPMS indexes are weighted to reflect the impact of the OM on switch performance.

Figure 7-1 shows the highest levels of the SPMS indexing hierarchy. The levels are described in Table 7-1.

**Figure 7-1 SPMS indexing hierarchy**

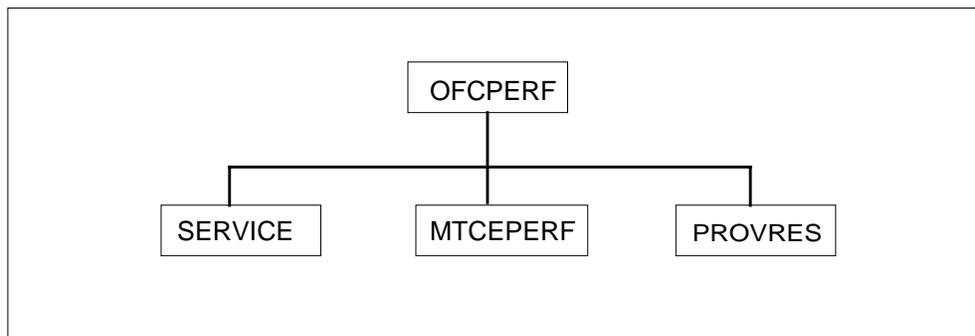

Table 7-1 lists and describes the SPMS index levels.

**Table 7-1 SPMS indexes**

Level	Description
OFCPERF	Office Performance Index: A summary of total office performance computed from the weighted average of its three direct descendants.
SERVICE	Service Performance Index: A summary of the contributions of maintenance and traffic provisioning to the overall service results.
MTCEPERF	Maintenance Performance Index: A summary of switch performance as observed by a person running the switch.
PROVRES	Provisionable Resource Index: A summary of the performance of traffic.



Table 7-2 summarizes the SPMS indexes of performance ratings.

**Table 7-2 SPMS indexes of performance ratings**

Level	Description
100	perfect
96-99	above average
95	average
91-94	below average
90 or less	much below average

**Note:** An index of 90 or less indicates a situation that requires correction.

Use SPMS daily to detect and correct maintenance and provisioning problems that other methods cannot detect. SPMS indicates trends that can lead to problems. Some indicators that help to identify trends include the following:

- call processing performance rating
- CPU occupancy indicator
- SWACT indicator
- NETINTEG indicator
- automatic trunk test (ATT) indicator

For more information about SPMS, refer to the *Switch Performance Monitoring System Application Guide*, 297-1001-330, which provides lists of all the indexes. The list provides the following information for each index:

- a description of the index
- a definition of the index
- a list of the OMs used to calculate the index
- a description of how the index is normalized
- the name of the diagnostic used to investigate the problem shown by the index

The *Switch Performance Monitoring System Application Guide*, 297-1001-330, also describes the relationship between OMs and SPMS indexes, and contains procedures for creating custom reports.

### **Call processing performance rating**

The call processing performance (CPPERF) indicator displays information about total call attempts, total lost calls, and completion percentage during the

past 24 h. From this data, the program calculates a completion percentage. When the completion percentage begins to decrease, call processing performance requires more investigation.

### **CPU occupancy indicator**

The CPU occupancy indicator provides the high water mark for CPU usage during a specified report period. The indicator provides the current setting for the high water mark and peg counts the number of times the CPU threshold, set to a default value of 60%, was exceeded. If the threshold count is exceeded several times, investigate this problem further.

### **SWACT indicator**

The PM SWACT indicator provides a list of PMs that have undergone a SWACT. The items contained in the indicator include the PM type, and a count of manually-initiated, system-initiated, cold, and warm SWACTs. If the report shows system-initiated SWACTs, corrective maintenance can be required.

### **Network integrity fail count indicator**

The NETINTEG indicator provides a peg count of network integrity failures and a peg count of total calls. The number of network integrity failure reports is equal to the number of integrity failures received from all the PM controllers in the switch.

### **Automatic trunk test (ATT) indicator**

The ATT indicator provides counts of the number of trunks tested, passed, failed, and skipped by the ATT feature for the past 24 h.

## **Routine exercise tests**

Routine exercise tests (REx testing) is the primary preventive maintenance tool for equipment with two units, such as the PRI XMS-based peripheral modules (XPM). REx tests run automatically, but must be enabled manually as follows:

### ***REx tests***

- 1 Schedule the REx test by datafilling the parameter NODEREXCONTROL in table OFCVAR.
- 2 Enable the REx test on individual XPMs by first posting the XPM, and then using the TST REX ON/OFF command.

**Note:** For more information about the office parameter NODEREXCONTROL, refer to the *Office Parameters Reference Manual*.

The DMS switch generates Log PM600 when a REx test fails. The log provides the following information:

- steps performed by the REx test
- reason for failure for the step that failed
- start time of each step

- peripheral node and unit status
- location of the XPM

If a REx test fails and the DMS switch generates log PM600, then logs PM131, PM128, and PM181 are suppressed. For more information about PRI logs, refer to the chapter “Logs.”

### **REx test sequence**

The REx test controller performs the following steps:

#### ***REx test sequence***

- 1 Test the inactive unit (in-service tests only).
- 2 Busy the inactive unit.
- 3 Return the inactive unit to service (out-of-service tests only).
- 4 Wait for superframe and data synchronization to be achieved.
- 5 Perform a pre-SWACT audit.
- 6 Perform a warm SWACT.
- 7 Busy the newly inactive unit.
- 8 Return the inactive unit to service
- 9 Wait for superframe and data synchronization to be achieved.
- 10 Test the newly active unit (in-service tests only).
- 11 Test the inactive unit (in-service tests only).

### **REx test restrictions**

Certain operating conditions limit the ability of the system to perform automatic REx tests and include the following:

- the XPM must not be overloaded
- the REx test ends instead of performing a cold SWACT, if a warm SWACT is not possible

The following restrictions apply to REx tests:

- For a REx test to run, the node must be in one of the following states:
  - in-service (InSv)
  - in-service trouble (ISTb) because a previous REx test failed
  - in-service trouble (ISTb) because the P-side DS-1 links are out of service
- If a restart occurs while a REx test is in progress, the DMS switch does not generate log PM600 because restart deallocates the temporary data store used to build the PM600 log.
- No SWACT controller override is provided for manual REx tests.

The following notes also apply to REx testing:

- OMs normally generated for certain system actions are suppressed if the REx test initiates the action.
- The last REx test date and time stored in the maintenance record can be due to either a system or manual REx test and is measured from the last system reload restart.
- The REx test maintenance record is maintained during warm and cold restarts and is re-initialized during reload restarts and BCS applications.

## Network maintenance

For the network to function correctly, a low bit error rate (BER) must be maintained. Table 7-3 lists the different tools that identify a bit error rate. For example, the bit error rate test (BERT) gives a measure of the transmission quality of a line or trunk. The test consists of sending a stream of known data over a specified B-channel on a DS-1 and comparing the returned signals.

Table 7-3 lists the resident DMS-100 tools in use for network maintenance and low bit error rate testing.

**Table 7-3 Test tools available for network maintenance**

Test tool	Use
Integrated bit error rate testing (IBERT)	Tests the subscriber's data path
Integrity check traffic simulator (ICTS)	Simulates high volume calling to exercise every network link and channel to every XPM in the office.
Network fabric testing feature (NETFAB)	Identifies network problems by automatically integrating its testing procedure with that of ICTS.
XPM bit error rate testing (XPM/LCM XBERT)	Detects BER errors in the XPM/LCM configuration.
Bit error rate performance (BERP)	Assesses BER performance in the switch.
NETPATH	Performs fault isolation and verification on the network components of a speech path.
NETINTEG	Analyzes network integrity.

## Focused maintenance

Although not strictly a preventive maintenance tool, focused maintenance (FM) can help identify potential troubles on trunks, and XPMs.

Focused maintenance is a tool for managing trunk and line log messages. FM techniques can reduce trunk and line log messages by up to 80%.

FM uses buffers to collect failure data, which are output in log messages (FM100 for trunk groups) when preset thresholds are exceeded. An alarm can also generate. To review Information concerning any alarms, access the appropriate MAP level, that is, TRKSTRBL.

The operation of FM is described in detail in “Section 197 (Lines)” in the data schema section of the *Translations Guide*.

### Operational measurements

Operational measurements (OM) are counts of events or changes of state in the DMS-100 switch that reflect the performance of the system. Single events measured individually are referred to as peg counts. Sampled states are in use to determine system resource usage and are called usage counts. Usage counts are sampled during a scan. A scan period is either 10 or 100 s.

There are greater than 2000 OMs organized into approximately 150 OM groups. OMs are the most significant information source for determining service-affecting problem conditions, both immediate and potential. Analysis of OMs can be based on measurements collected over a long period of time. For example, one month, or based on measurements collected in a few minutes (real-time analysis).

For more information about ISDN PRI OMs, refer to the chapter “Operational measurements.”

### Routine maintenance

On-going maintenance aims to sustain the network and XPMs at the high-speed data transmission criterion of less than two NET102 log messages for every 10 000 calls at a parity threshold of 1.

The operating company personnel performs preventative routine maintenance procedures based on the schedule in Table 7-4.

**Table 7-4 Recommended routine maintenance procedures (Sheet 1 of 2)**

Procedure	Interval
ALT analysis	Daily
ATT analysis	Daily
Automatic BIC relay test	Weekly
BERP	Daily

**Table 7-4 Recommended routine maintenance procedures (Sheet 2 of 2)**

<b>Procedure</b>	<b>Interval</b>
Circuit test	Daily
Extended diagnostics	Daily
IBERT	Daily
ICTS	Determined by operating company personnel
NETFAB	4 h every night (continuous)
NETINTEG	Determined by operating company personnel
Replacement of cooling filters	Every 3 months
REx testing	Daily
Short diagnostics (SDIAG)	Daily
Switch BER indicator for trunks	Determined by operating company personnel
Testing of wrist strap grounding cords	Monthly
TRKBERT	Determined by operating company personnel
Verification and adjustment (if required) of time of day clock	Daily
XPM/LCM XBERT	Determined by operating company personnel

For further information regarding routine maintenance procedures, see *Routine Procedures*.



---

## 8 Logs

---

This chapter contains the following information:

- background information about PRI logs
- the log number associated with ISDN PRI
- the priority logs and the actions to take for each log

### Log reports

Log reports are messages the DMS-100 switch generates whenever a significant event occurs. A significant event can occur when the DTCTI changes from an in-service state to a system-busy state. Log reports include status and activity reports. Log reports also include reports on hardware or software faults, test results, state changes, and other events or conditions that can affect the performance of the DMS switch.

For more information about log reports, refer to the *Log Report Reference Manual*.

### Log utility

The log utility (LOGUTIL) allows you to browse through software buffers for information about messages and temporarily to control the routing and generation of output reports.

### ISDN PRI logs

Table 8-1 lists all logs associated with ISDN PRI and includes a description of each log.

PM logs generate for all types of peripherals in the office; however, the descriptions in the table describe the ISDN PRI XMS-based peripherals, the DTCTI, and the LTC only. PM logs contain a peripheral identification field in



the first line of the log. For ISDN PRI peripherals, this field contains the abbreviations DTCI or LTC.

**Table 8-1 Summary of ISDN PRI related logs (Sheet 1 of 6)**

Logs		Definition
All trunks busy logs	ATB100	An attempt to seize a trunk was blocked and the call advances to another route.
ISDN logs	ISDN103	A manual action changed the state of the B-channel.
	ISDN105	Synchronization was lost on the B-channel, and the B-channel was removed from service.
	ISDN110	One D-channel is in service and the other D-channel is in standby.
	ISDN111	One D-channel is active and the other D-channel is out of service.
	ISDN112	Both D-channels in a dual configuration are out of service, or the D-channel in a single configuration is out of service.
	ISDN113	A manual D-channel switchover occurred. The log shows the active and out-of-service D-channels after the switchover.
	ISDN114	An automatic D-channel switchover occurred. The log shows the active and out-of-service D-channels after the switchover.
	ISDN118	Synchronization has been established on the D-channel.
	ISDN401	Twenty-four hour report giving details of the transmission performance of a single NTNI PRA D-channel.
	ISDN402	Twenty-four hour report giving details of layer 2 and layer 3 high protocol abnormalities of a single NTNI PRA D-channel.
ISDN404	Twenty-four hour report provides counts on the accessibility of the billing counters that are maintained on a per routelist basis. This log is associated with the Call Forward/Interface Busy feature.	
Network logs	NET130	A network path was not found.

Table 8-1 Summary of ISDN PRI related logs (Sheet 2 of 6)

Logs		Definition
Network management subsystem logs	NWM100	The Directional Reservation Equipment (DRE) feature was turned on or off for a trunk group.
	NWM101	The Protectional Reservation Equipment (PRE) feature was turned on or off for a trunk group.
	NWM102	A cancel-to (CANT) network management control was applied to or removed from a trunk group.
	NWM103	A cancel-from (CANF) network management control was applied to or removed from a trunk group.
	NWM104	A skip (SKIP) network management control was applied to or removed from a trunk group.
	NWM105	The Incoming Trunk Busy (ITB) feature was activated or deactivated on the incoming trunk group.
	NWM106	The Selective Trunk Reservation (STR) feature was activated or deactivated on the incoming trunk group.
NWM107		A flexible reroute (FRR) control was applied to or removed from a two-way or outgoing trunk group.
Peripheral module logs	PM101	An XPM failed a checksum test (CHKSUM-TST).
	PM102	An XPM changed state to system busy (SysB) because of a system request.
	PM103	An XPM changed from manual busy (ManB) to off-line (OffL), or an XPM has been added to the LTCINV inventory table while OffL and unequipped (Uneq).
	PM104	An XPM changed from off-line (OffL) to unequipped (Uneq), or a tuple was deleted from the LTCINV inventory table.
	PM105	An XPM changed to manual busy (ManB).
	PM106	An XPM was returned to service (RTS).

**Table 8-1 Summary of ISDN PRI related logs (Sheet 3 of 6)**

Logs	Definition
PM107	An XPM changed to central-side busy (CBsy) because of a system-busy request or a manual-busy request from the C-side node.
PM108	The peripheral processor has a firmware or hardware error.
PM109	The T1 carrier line changed to system busy (SysB).
PM110	A change occurred in the service count level. No trunks are removed from service when an out-of-service limit is set; however, since 24 trunks are affected, maintenance personnel must determine whether to deload the trunks using the trunk test position (TTP).
PM112	This log is generated every 24 h for each digital carrier module when the DMS-core sets the T1 carrier slip counter to zero (0).
PM113	Message congestion occurred in a peripheral processor.
PM114	An XPM load, test, initialization, or return-to-service procedure failed.
PM115	Miscellaneous trouble occurred on the peripheral processor during normal operation.
PM116	Message error report from an XPM
PM117	Trouble during normal operation
PM118	Miscellaneous trouble occurred on the peripheral processor during normal operation. This report contains a field that defines which plane of the XPM is affected. PM115 does not contain this field.
PM128	An XPM changed to in-service trouble (ISTb).
PM179	A hardware condition affected the normal operation of the DMS-100 switch or its XPM. This log supplies information for the XPM hardware exception report.

Table 8-1 Summary of ISDN PRI related logs (Sheet 4 of 6)

Logs	Definition
	PM180 An XPM encountered a software exception, that is, an occurrence of an improper execution of the software. This log can also be generated due to a hardware-related software exception.
	PM181 An XPM exception occurred as a result of diagnostics.
	PM182 An XPM P-side link changed to manual busy (ManB).
	PM183 An XPM P-side link changed to system busy (SysB).
	PM184 An XPM P-side link was returned to service (RTS).
	PM185 The XPM software trapped.
	PM187 An XPM carrier changed to system busy (SysB).
	PM188 A XPM carrier was returned to service (RTS) or was protection-switched.
	PM189 An XPM encountered a minor software exception output as a software information report.
	PM600 An XPM failed a REx test.
Trunk logs	TRK101 The percentage of busy trunks reached or exceeded the threshold value for a minor alarm.
	TRK102 The percentage of busy trunks reached or exceeded the threshold value for a major alarm.
	TRK103 The percentage of busy trunks reached or exceeded the threshold value for a critical alarm.
	TRK104 The percentage of busy trunks drops below the threshold for a minor, major, or critical alarm.
	TRK106 A diagnostic test on trunk equipment failed.
	TRK109 A diagnostic test on a DS-1 facility failed.
	TRK110 A facility problem occurred and the trunk state is changed from call processing busy (CPB) to system busy (SysB) or Lockout (LO).

**Table 8-1 Summary of ISDN PRI related logs (Sheet 5 of 6)**

Logs	Definition
TRK111	Trouble occurred or treatment was assigned during the routing of an incoming trunk to trunk call.
TRK113	Trouble occurred during the call processing of a trunk-to-trunk call.
TRK114	Trouble occurred during dial pulse (DP) reception for an incoming call over a trunk, and the call destination was not determined.
TRK115	Trouble occurred during dial pulse (DP) reception for an incoming call over a trunk, and the call destination was not determined.
TRK116	Trouble occurred during multifrequency (MF) reception for an incoming call over a trunk, and the call destination was not determined.
TRK117	Trouble occurred during multifrequency (MF) reception for an incoming call over a trunk, and the call destination was not determined.
TRK118	Trouble occurred during automatic number identification (ANI) spill for an incoming call over a trunk and the call origination address was not determined.
TRK119	An operator keyed in the originating station number identification and then released the call because trouble occurred with DMS automatic number identification.
TRK121	Trouble occurred during the outpulsing of a call on a specific outgoing trunk.
TRK122	The DMS-core detected integrity loss on both planes of the trunk equipment.
TRK138	A call was routed to treatment after being call processing busy.
TRK162	Trouble occurred during the outpulsing of a trunk-to-trunk call or a line-to-trunk call using digital multifrequency (DTMF) signaling.
TRK182	Trouble occurred during Digitone (DGT) reception for an incoming call over a trunk and the call destination was not determined.

**Table 8-1 Summary of ISDN PRI related logs (Sheet 6 of 6)**

Logs	Definition
TRK183	Trouble occurred during Digitone (DGT) reception for an incoming call over a trunk, and a permanent signal problem occurred.
TRK213	Trouble occurred on the identified trunk.

## Priority logs

ISDN PRI priority logs are categorized in the following way:

- service-affecting logs
- potential-service affecting logs
- provisioning and engineering information logs

Service-affecting logs indicate a loss of service. Potential service-affecting logs indicate a potential loss of service if it involves more than one component. For example, if one D-channel goes out of service, the DMS switch generates PM111, and maintains service if the backup D-channel is in service. If the backup D-channel goes out of service (OOS), the DMS switch generates PM112 and interrupts service. Provisioning and engineering information logs indicate that not enough resources are available to provide service. Successive occurrences of provisioning and engineering information logs indicate that the operating company needs to upgrade its office capacity.

Table 8-2 lists the service-affecting logs for ISDN PRI. The table includes the alarm class, where applicable, and the action to take for each log.

**Table 8-2 ISDN PRI service affecting logs (Sheet 1 of 2)**

Log	Alarm class	Action
ISDN112	critical	Return the OOS D-channels to service. If the alarm continues, ensure that the transmission line is functioning properly by performing either a continuity test (CONT) or a loopback test (LOOPBK).
PM102	critical	Clear the alarm by performing the DTCI or LTCI alarm clearing procedure in <i>Alarm and Performance Monitoring Procedures</i> .  If the DS-1 link is out of service, clear the alarm by performing the appropriate TRK alarm clearing procedure in <i>Alarm and Performance Monitoring Procedures</i> .

**Table 8-2 ISDN PRI service affecting logs (Sheet 2 of 2)**

Log	Alarm class	Action
PM107	minor	Determine if a network alarm is present. Clear the alarm by performing the appropriate Net alarm clearing procedure in <i>Alarm and Performance Monitoring Procedures</i> .
PM109	minor	If this log appears for less than 2 min, do not take any action.  If this log appears for more than 2 min, clear the alarm by performing the DTCL or LTCL alarm clearing procedure in <i>Alarm and Performance Monitoring Procedures</i> .
PM183	minor	Perform tests and diagnostics on the P-side link. Clear the alarm by performing the appropriate TRK alarm clearing procedure in <i>Alarm and Performance Monitoring Procedures</i> . PM110 may appear at the same time as PM183. PM110 is useful for determining the cause of the change of state to system busy.
PM187	no alarm	Clear the alarm by performing the appropriate TRK alarm clearing procedure in <i>Alarm and Performance Monitoring Procedures</i> .
TRK122		Clear the alarm by performing the appropriate TRK alarm clearing procedure in <i>Alarm and Performance Monitoring Procedures</i> .

Table 8-3 lists the potential service-affecting logs for ISDN PRI. The table includes the alarm class, where applicable, and the action to be taken for each log.

**Table 8-3 ISDN PRI potential service affecting logs (Sheet 1 of 3)**

Log	Alarm class	Action
ISDN111	major	Return the out-of-service (OOS) D-channel to service. If the alarm continues, ensure that the transmission line is functioning properly by performing either a continuity test (CONT) or a loopback test (LOOPBK).
ISDN114	major	Return the OOS D-channel to service. If the alarm continues, ensure that the transmission line is functioning properly by performing either a continuity test (CONT) or a loopback test (LOOPBK).

Table 8-3 ISDN PRI potential service affecting logs (Sheet 2 of 3)

Log	Alarm class	Action
PM101		Repeat the CHECKSUM test. If the test fails, replace the card by performing the appropriate card replacement procedure in <i>Card Replacement Procedures</i> . Rerun the test. If the test fails, replace the next card on the card list. Continue until the test passes or until all the cards on the card list have been replaced.
PM108	minor	Clear the alarm by performing the DTCl or LTCl alarm clearing procedure in <i>Alarm and Performance Monitoring Procedures</i> .
PM110	minor	If the maintenance limit is cleared, do not take any action.  If the maintenance limit or out-of-service limit is set, clear the alarm by performing the appropriate TRK alarm clearing procedure in <i>Alarm and Performance Monitoring Procedures</i> .
PM115	no alarm	If this log appears with log PM108, clear the alarm by performing the DTCl or LTCl alarm clearing procedure in <i>Alarm and Performance Monitoring Procedures</i> .
PM116	no alarm	If this log is preceded by log PM108, clear the alarm by performing the DTCl or LTCl alarm clearing procedure in <i>Alarm and Performance Monitoring Procedures</i> .
PM117	minor	Clear the alarm by performing the PM ISTb alarm clearing procedure in <i>Alarm and Performance Monitoring Procedures</i> .
PM118	no alarm	If this log appears less than three times over a period of 2 min, do not take any action.  If this log appears with log PM108, clear the alarm by performing the DTCl or LTCl alarm clearing procedure in <i>Alarm and Performance Monitoring Procedures</i> .  If no fault is found, try reloading the XPM.
PM128	minor	Clear the alarm by performing the PM ISTb alarm clearing procedure in <i>Alarm and Performance Monitoring Procedures</i> .



**Table 8-3 ISDN PRI potential service affecting logs (Sheet 3 of 3)**

Log	Alarm class	Action
PM179		Test the XPM. If the test fails, replace the card by performing the appropriate card replacement procedure in <i>Card Replacement Procedures</i> . Rerun the test. If the test fails, replace the next card on the card list. Continue until the test passes or until all the cards on the card list have been replaced.
PM180	minor	If the character string indicates a hardware problem, perform diagnostic maintenance on the suspect equipment.  Clear the alarm by performing the DTCI or LTCI alarm clearing procedure in <i>Alarm and Performance Monitoring Procedures</i> .
PM600	major	Clear the alarm by performing the DTCI or LTCI alarm clearing procedure in <i>Alarm and Performance Monitoring Procedures</i> .
TRK109	no alarm	Perform the appropriate card replacement procedure in <i>Card Replacement Procedures</i> .

Table 8-4 lists the provisioning and engineering information logs for ISDN PRI. The table includes the alarm class, where applicable, and the action to be taken for each log.

**Table 8-4 ISDN PRI provisioning and engineering information logs (Sheet 1 of 2)**

Heading	Heading	Heading
ATB100	minor	Save all ATB100 reports for the network planning personnel.
PM113	minor	If this log appears for less than 2 min, do not take any action.  If this log appears for more than 2 min, clear the alarm by performing the appropriate alarm clearing procedure in <i>Alarm and Performance Monitoring Procedures</i> .
TRK101	minor	Clear the alarm by performing the appropriate TRK alarm clearing procedure in <i>Alarm and Performance Monitoring Procedures</i> .

**Table 8-4 ISDN PRI provisioning and engineering information logs (Sheet 2 of 2)**

Heading	Heading	Heading
TRK102	major	Clear the alarm by performing the appropriate TRK alarm clearing procedure in <i>Alarm and Performance Monitoring Procedures</i> .
TRK103	critical	Clear the alarm by performing the appropriate TRK alarm clearing procedure in <i>Alarm and Performance Monitoring Procedures</i> .

### Logs introduced in NA014

NA014 introduced no new logs.



## 9 Operational measurements

This chapter describes ISDN PRI operational measurements (OM). Operational measurements are a useful surveillance tool for ISDN PRI. Use OM information for real-time maintenance activities, long-term maintenance analysis, and administration.

### ISDN PRI OM groups

Table 9-1 lists the OM groups for ISDN PRI. For details about OM registers, refer to the *Operational Measurements Reference Manual*.

For details about how to activate OMs, refer to *Basic Administration Procedures*, 297-1001-300.

**Table 9-1 ISDN PRI and ISDN PRI related OM groups (Sheet 1 of 2)**

Group	Description
DS1CARR	DS1CARR provides information about maintenance thresholds and out-of-service (OOS) thresholds for digital trunks on peripheral modules (XPM). When the OOS threshold is exceeded, the DS-1 is removed from service until it is manually returned to service.
PM	PM provides information on the performance of dual-unit XPMs: for PRI, this includes DTCIs and LTCs.
PRADCHL2	PRADCHL2 monitors the performance of PRI D-channel layer 2 traffic.
PRAFAC	PRAFAC measures message traffic that is generated by Network Ring Again (NRAG) on primary rate access (PRA) D channels.

## 9-2 Operational measurements

---

**Table 9-1 ISDN PRI and ISDN PRI related OM groups (Sheet 2 of 2)**

<b>Group</b>	<b>Description</b>
RTESVCS	RTESVCS collects the number of Call Forward/Interface Busy (CFIB) attempts
TRK	TRK provides information on trunk traffic for each trunk group.

The following table lists the ISDN PRI performance factors and their related OM groups, registers, and logs.

**Table 9-2 ISDNOM registers (Sheet 1 of 3)**

<b>Performance factor or system fault</b>	<b>OM group</b>	<b>Registers</b>	<b>Associated logs</b>
DS-1 link availability, DS-1 link failures	DS1CARR	DS1AIS	none
		DS1BER	none
		DS1BPV	none
		DS1CBU	PM107
		DS1ECF	TRK109
		DS1ES	none
		DS1LCGA	PM109, TRK109
		DS1LOF	PM110
		DS1MBU	PM105, PM182
		DS1PBU	PM183
		DS1RCGA	PM109, TRK109
		DS1SBU	PM109, TRK109
		DS1SES	none
		DS1SLP	PM112
		DS1UAS	none
Module faults	PM	PMCCTDG	LINE101, LINE131
		PMCCTFL	LINE101
		PMCCTOP	none
		PMERR	NET102, PM101, PM108, PM113, PM115, PM116, PM117, PM118, PM119, PM121, PM122, PM124, PM125, PM126, PM128, PM150, PM 160, PM180, PM181, PM190, PM194, PM198, PM270, TRK123
		PMFLT	PM100, PM101, PM102, PM114, PM117, PM122, PM151, PM161, PM162, PM164, PM180, PM181, PM185, PM 199
		PMINTEG	NET102, PM101, PM108, PM113, PM118, PM119, PM122, PM124, PM180, PM181, PM182, PM185, PM191

Table 9-2 ISDNOM registers (Sheet 2 of 3)

Performance factor or system fault	OM group	Registers	Associated logs		
Module faults (continued)	PM	PMMBP	PM182, PM191		
		PMMBTCO	none		
		PMMCXFR	PM128, PM180		
		PMMMBU	PM105, PM128, PM170, PM182, PM191		
		PMMSBU	PM102, PM128, PM170, PM183, PM190, PM192		
		PMMWXFR	PM102, PM128, PM183		
		PMPSEERR	PM110, PM181, PM183		
		PMPSEFLT	PM109, PM181, PM183		
		PMRGERR	PM109, PM181, PM183		
		PMRGFLT	PM161, PM162, PM163		
		PMSBP	PM107, PM183, PM190, PM192		
		PMSBTCO	none		
		PMSCXFR	PM128, PM179, PM180, PM181		
		PMSWXFR	PM128, PM179, PM180, PM181		
		PMUMBU	PM105, PM128, PM182, PM191		
		PMUSBU	PM102, PM128, PM152, PM183, PM190, PM192		
		DS-1 link performance, DTCI overload, PRI D-channel traffic, D-channel failures	PRADCHL2	PRDCRC	none
				PRDDISCR	none
PRDDISCT	none				
PRDL2SVD	none				
PRDL3SVD	none				
PRDREJRX	none				
PRDREJTX	none				
PRDRNRRX	none				
PRDRNRTX	none				
PRDSORX	none				
PRDSOTX	none				
PRDSBMRX	none				
PRDSBMTX	none				
PRFLSHED	none				

Table 9-2 ISDNOM registers (Sheet 3 of 3)

Performance factor or system fault	OM group	Registers	Associated logs
Network traffic on PRI D-channels, D-channel failures	PRAFAC	FACMSGOR	none
		FACMSGTM	none
		FACMSGTR	none
		DISNORTX	none
		DISCNGST	none
		DISRTUNA	none
		REJMSGOR	none
		REJMSGTM	none
		REJMSGTR	none
		REJMSGDS	none
		REJNORTX	none
		REJCNGST	none
		REJRTUNA	none
		Trunk group performance	TRK
AOF	TRK118, TRK119		
CONNECT	none		
DEFDCA	NWM100, NWM101, NWM102, NWM103, NWM104, NWM106, NWM108		
DREU	NWM100		
GLARE	TRK113, TRK121		
INCATOT	none		
INFAIL	TRK111, TRK114, TRK115, TRK116, TRK117, TRK138, TRK182, TRK183, TRK213		
MBU	TRK213		
NATTMPT	none		
NOVFLATB	none		
OUTFAIL	ATB100 TRK113, TRK121, TRK122, TRK162,		
OUTMTCHF	TRK213		
PRERTEAB	NET130		
PREU	TRK113, TRK116		
SBU	NWM101		
TANDEM	TRK106, TRK109		
TOTU	none		
TRU	none		



## ISDN PRI priority OM registers

ISDN PRI priority OM registers are classified in the following manner:

- service-affecting OM registers
- provisioning and engineering OM registers

Service-affecting OM registers indicate a loss of service. Successive occurrences of provisioning and engineering OM registers indicate that the operating company needs to upgrade its office capacity.

Table 9-3 lists the services affecting OM registers for ISDN PRI.

**Table 9-3 ISDN PRI service affecting OM registers (Sheet 1 of 3)**

Group	Register	Associated logs	Description
DS1CARR	DS1LCGA	PM109 TRK109	Counts each time the PM generates a local carrier group alarm message.
	DS1RCGA	PM109 TRK109	Counts each time the PM generates remote carrier group alarm messages.
	DS1PBU	PM183	Measures the amount of time (in CCS or decierlangs) that the DS-1 carrier is P-side busy. A carrier is P-side busy when its remote (P-side) PM is OOS.
	DS1SBU	PM109 TRK109	Measures the amount of time (in CCS or decierlangs) that the DS-1 carrier is system busy
PM	PMFLT	PM100 PM101 PM102 PM114 PM117 PM122 PM151 PM161 PM162 PM164 PM180 PM181 PM185 PM 199	Counts the number of faults in either unit of an in-service XPM that causes the unit or the XPM to become system busy.

Table 9-3 ISDN PRI service affecting OM registers (Sheet 2 of 3)

Group	Register	Associated logs	Description
	PMMSBU	PM102 PM128 PM170 PM183 PM190 PM192	Records the time (in CCS) that the PM is SysB. Scored when either both units are SysB or one unit is SysB and the other unit is in a not-in-service state.
	PMPSFLT	PM109 PM181 PM183	Counts the number of faults detected on facilities associated with the PM.
	PMSBTCO	none	Scored for every terminal in the call processing busy (CPB) or the call processing deload (CPD) state when the PM is made system busy (SysB) or central-side busy (CBsy). For two terminals involved in a two-port call, the peg is scored only once.
	PMUSBU	PM102 PM128 PM152 PM183 PM190 PM192	Records the time (in CCS) that the PM is SysB.
TRK	INFAIL	TRK111 TRK114 TRK115 TRK116 TRK117 TRK138 TRK182 TRK183 TRK213	Counts the number of events that occurred for an originating call on a trunk before the call failed. Causes include permanent signal, partial dial time out, or bad digits.

**Table 9-3 ISDN PRI service affecting OM registers (Sheet 3 of 3)**

<b>Group</b>	<b>Register</b>	<b>Associated logs</b>	<b>Description</b>
	OUTFAIL	TRK113 TRK121 TRK122 TRK162 TRK213	Counts the number of failed attempts to seize an outgoing trunk in the group due to seizure failures, signaling problems, loss of integrity, or outgoing failures.
	SBU	TRK106 TRK109	Measures the amount of time (in CCS or decierlangs) that a trunk is in one of the following states: remote busy, peripheral module busy, system busy, carrier fail, or deloaded.

Table 9-4 lists the provisioning and engineering OM registers for ISDN PRI.

**Table 9-4 ISDN PRI provisioning and engineering OM registers**

Group	Register	Associated logs	Description
PM	PMERR	NET102 PM101 PM108 PM113 PM115 PM116 PM117 PM118 PM119 PM121 PM122 PM124 PM125 PM126 PM128 PM150, PM 160 PM180 PM181 PM190 PM194 PM198 PM270 TRK123	The number of errors detected for an in-service PM regardless of further maintenance action.
PRADCHL2	PRDS0RX	none	Counts the number of successfully received SAPI0 frames.
	PRDS0TX	none	Counts the number of successfully transmitted SAPI0 frames.
TRK	NOVFLATB	ATB100	Counts the number of times that call processing overflows a trunk group because there are no idle trunks.

### OM groups introduced in NA014

NA014 introduced no new OM groups or registers.



---

# 10 Advanced troubleshooting procedures

---

This chapter contains advanced troubleshooting procedures that are referenced from the troubleshooting table in chapter “Troubleshooting chart”.

When performing troubleshooting procedures for major failures or potential failures, it is crucial to coordinate local and regional control centers.

## **B- and D-channel troubles**

Use this procedure to detect faults on B- and D-channels that do not come into service.

This procedure contains several steps that require you to check datafill. For more information about ISDN PRI datafill, refer to the *Translations Guide*.

For more information about the types of B- and D-channel problems that occur, refer to chapters "Trouble isolation and correction methods" and "Troubleshooting chart" in this document.

1. Review maintenance actions taken to date, including checking the physical spans for wiring and continuity, and using BERT to train the trunks. Repeat any of these maintenance actions if necessary.

Refer to the section "Some notes on troubleshooting" in the chapter "Trouble isolation and correction methods" in this document for more information about basic troubleshooting.

**Table 10-1**

<b>If the B- or D-channel problem</b>	<b>Go to</b>
still exists	step 2
no longer exists	step 12

2. Check that the peripherals in use for the PRI trunks contain the correct datafill. In table LTCINV, make sure that the datafill in
  - Field EXECTAB (executive table) subfield TRMTYPE (terminal type) is PRAB
  - Field EXECTAB subfield EXEX (executive program) is DTCEX
  - Field OPTCARD (optional card) is ISP16

**Table 10-2**

<b>If the B- or D-channel problem</b>	<b>Go to</b>
still exists	step 3
no longer exists	step 12

3. Check that the frame format and the line coding design in use in the DS-1 link is compatible with the far-end equipment. In table CARRMTC field ATTR (attributes), check that the
  - Subfield FF (frame format) matches the far-end equipment. The frame type is ESF for extended superframe and SF for superframe.
  - Subfield ZLG (line coding design) matches the far-end equipment. The entry is either B8ZS for 64-kbit/s clear communication or ZCS for 56-kbit/s restricted information.
  - Subfield BERB (bit error rate base) matches the entry in FF. The entry is BPV when subfield FF is SF, and CRC when subfield FF is ESF.

*Note:* Extended superframe format (ESF) requires feature package NTX143 and the NT6X50AB cards to run.

**Table 10-3**

If the B- or D-channel problem	Go to
still exists	step 4
no longer exists	step 12

4. Check the P-side link assignments for the DTCI in table LTCPSINV. Table LTCPSINV contains an entry for each DTCI.

Check that field PSLNKTAB (P-side link table) data is correct. Pay special attention to the contents of subfield IID (interface identifier).

Each P-side link has an associated IID that must match the far-end. If there is more than one P-side link in a trunk group, the IID for each link is unique and entered in ascending sequential order. You can set the IID to a specific value depending on the number of P-side links, the D-channel configuration, and the far-end equipment.

#### **Number of P-side links**

If a trunk group contains several P-side links, the datafill IID values must be in ascending order. For example, if there are four P-side links in a trunk group, the datafill IID values are 0, 1, 2, and 3. The links do not need to be in consecutive order, but they must be in ascending order. For example, a trunk group in table LTCPINV contains datafill with P-side link values 3, 6, 8, 11, and 15—but the associated IIDs datafill must be 0, 1, 2, 3, and 4.

**DMS/SL-1 configuration** The D-channel configuration (single or backup) affects required IID values. A P-side link with

- a primary D-channel must have an IID of 0
- a backup D-channel must have an IID of 1



The number of links also affects IID values in a DMS/SL-1 configuration. If there is more than one link in a trunk group without a backup D-channel, and the D-channel is on the first P-side link, fill the IIDs with the values 0, 2, and 3.

**DMS/SL-100 configuration**

In the DMS/SL-100 configuration, the D-channel configuration (single or backup) does not affect required IID values.

**Table 10-4**

<b>If the B- or D-channel problem</b>	<b>Go to</b>
still exists	step 5
no longer exists	step 12

5. Check the D-channels for the trunk group in table TRKSGRP. In field SGRPVAR (Subgroup variable refinement), check that the
  - Subfield IFCLASS (interface class) datafill is either the value NETWORK or USER. Coordinate this subfield with the far-end meaning one end is NETWORK and the other end is USER.
  - Subfield L1FLAGS (layer 1 flags) datafill is the appropriate value. If the far-end equipment is an SL-1, set the L1FLAGS to Y. If the far-end equipment is any other Northern Telecom product, L1FLAGS datafill should be N. When the far-end equipment is not manufactured by Northern Telecom, L1FLAGSDatafill should be Y.
  - Subfield DCHNL (D-channel) datafill is the primary and backup D-channel to be used for the PRI interface.
  - Subfield DCHRATE (D-channel rate) datafill is the correct data rate of the D-channel. This field must be compatible with subfield ZLG in table CARRMTC. If subfield ZLG is set to ZCS, DCHRATE must be 56K; if ZLG is B8ZS, DCHRATE must be 56 or 64K. Make sure the value is the same as the far end.
  - Subfield HDLCTYPE (high level data link type) datafill is correct and matches the nearest equipment.

**Table 10-5**

<b>If the B- or D-channel problem</b>	<b>Go to</b>
still exists	step 6
no longer exists	step 12

6. Check the following information on B-channels in table TRKMEM.
- Field EXTRKNM (external trunk name) contains an external number to identify the trunk number
  - Field SGRP (subgroup) contains the value 0
  - Field MEMVAR (member variables) datafill is for DTICI or LTC

Make sure that the DS-1 circuit numbers and B-channel time slot numbers are in ascending sequential order.

**Table 10-6**

<b>If the B- or D-channel problem</b>	<b>Go to</b>
still exists	step 7
no longer exists	step 12

7. Check the datafill in table PRIPROF to make sure that the protocol variant and issue are defined. Check that field VARINFO (variant information)
- Subfield VARIANT datafill is correct for the type of protocol variant being used
  - Subfield ISSUE contains V1

**Table 10-7**

<b>If the B- or D-channel problem</b>	<b>Go to</b>
still exists	step 8
no longer exists	step 12

8. Check the PRI trunk group is assigned an LTID (logical terminal identifier) and access privileges. Table LTDEF identifies logical terminals and privileges.

Check that field CLASSREF subfield PROFNAME (profile name) datafill is the same value (name) as in table PRIPROF fields PROFNAME and VARINFO.

**Table 10-8**

<b>If the B- or D-channel problem</b>	<b>Do</b>
still exists	step 9
no longer exists	step 12

9. Try to bring the B- or D-channel back to service.

**Table 10-9**

<b>If the channel will</b>	<b>Go to</b>
not return to service	step 10
return to service	step 12

10. Gather relevant logs including TRK, PM, and ISDN logs and perform a protocol trace. For more information about priority logs, refer to the chapter “Logs” in this document.
11. For assistance, contact the personnel responsible for the next level of support.
12. You have completed this procedure.

## **Calls that do not complete**

Use this procedure to troubleshoot your equipment when calls do not complete.

### **Definition**

Some of the problems that can indicate a fault with call completion include the following:

- Customer complaints
- No circuit available announcement
- Negative test call results

Follow these steps to detect faults for calls that do not complete:

1. Review the maintenance actions taken to date.

Refer to “Troubleshooting steps” in this document for information about basic troubleshooting steps.

**Table 10-10**

If the problem	Go to
still exists	step 2
no longer exists	step 20

2. Check that the DMS switch has the following feature packages installed. PRI requires the following feature packages:

**Table 10-11**

Package number	Package name
NTX750AD	ISDN Basic Access
NTX790AC	ISDN-Primary Rate Access Base

The following feature packages are **optional** on the DMS switch for PRI:

**Table 10-12 (Sheet 1 of 2)**

Package number	Package name
NTX142AA	DS-1 64 kbit/s Clear
NTX143AA	DS-1—ESF
NTX767AA	TR-448 ISDN Digit Analysis Compliance—End Office
NTX768AA	TR-448 ISDN Digit Analysis Compliance—Toll
NTX791AA	ISDN PRA: Network Ring Again
NTX792AA	ISDN PRA: Network Name Display
NTX793AA	PRA Integrated Services Access
NTX794AA	PRA CCS7 Interworking
NTX795AA	INFO+ Enhanced Number Delivery—Primary Rate Interface
NTX797AA	PRI Message Waiting Indication

**Table 10-12 (Sheet 2 of 2)**

Package number	Package name
NTXE64AA	#4ESS AT&T Interworking
NTXJ43AA	#5ESS AT&T Interworking
NTXJ55AA	ISDNAP
NTXK55AA	Emergency Services Over ISDN
NTXN14AA	Trunks as SCAI ACD Agents
NTXN53AA	Enhanced PRA Maintenance
NTXN67AA	Meridian Automatic Route Selection
NTXQ74AA	NSS Customer Group Transport for PRI
NTXR34AA	XPM Plus (Product Line Upgrade Strategy) Basic
NTXR49AA	Dialable Wide Band Service PRI
NTXR65AA	Flexible DWS Access
NTXR66AA	DWS ATC ISUP
NTXS28AA	DWS Intertoll ISUP
NTXS36AA	XPM+ on DTCI

3. Determine if the problem is resolved.

**Table 10-13**

If the problem is	Go to
not resolved	step 4
resolved	step 20

4. Check that the far-end equipment has the software required to support the service being provided.

5. Determine if the problem is resolved.

**Table 10-14**

<b>If the problem is</b>	<b>Go to</b>
not resolved	step 6
resolved	step 20

6. Check the datafill in table TRKSGRP, field SGRPVAR, subfield CRLNGTH (call reference length). The CRLNGTH must match the far-end.
7. Determine what type of information should be in a layer 3 Q.931 protocol trace by determining the type of service being provided. The most important information to check for is the number of called digits and the call type. The call type is determined by the values of the NSF (network specific facilities) if the call is ISA (integrated service access), and the NPI (numbering plan indicator). This information must match the far-end.

Refer to the “ISA troubleshooting” section in the chapter “Trouble isolation and correction methods” for more information about NSF, ISA, and NPI.

**Table 10-15**

<b>If there is</b>	<b>Call type</b>
no NSF	call type is value of NPI
an NSF	call type is value of NSF

8. Perform a layer 3 (Q.931) protocol trace of the failed call to determine the messages actually being sent.
9. Determine if the incomplete call is an outgoing or incoming call.

**Table 10-16**

<b>If the call is</b>	<b>Go to</b>
outgoing	step 10
incoming	step 14

10. Check the outgoing setup message including the values of the NSF, the NPI, and the called digits. Obtain more information about the call by using TRAVER.

Refer to “Valid SETUP message response” for more information about setup messages.

**Table 10-17**

<b>If the setup message is</b>	<b>Go to</b>
correct	step 11
incorrect	step 12

11. Modifications must be made at the far-end equipment to accept the call. After you complete modifications at the far-end, test the call for completion.

**Table 10-18**

<b>If the call</b>	<b>Go to</b>
completes	step 20
does not complete	step 19

12. Modify the incorrect translations. Refer to the *Translations Guide*.
13. Perform a TRAVER and protocol trace to determine if the calls complete and the datafill is correct.

**Table 10-19**

<b>If data fill is correct and</b>	<b>Go to</b>
call completes	step 20
call does not complete	step 19

14. Check the incoming setup message including the values of the NSF, the NPI, the called digits, and the bearer capability. Obtain more information about the call by using TRAVER.

Refer to table “Valid SETUP message response” for more information about setup messages.

**Table 10-20**

<b>If the setup message is</b>	<b>Go to</b>
correct	step 16
incorrect	step 15

15. Make modifications at the far-end equipment to make sure that the proper information is received. After you complete modifications at the far-end, test the call will completion.

**Table 10-21**

<b>If the call</b>	<b>Go to</b>
completes	step 20
does not complete	step 16

16. Check that the translations are correct by issuing the proper TRAVER based on the NPI and NSF of the incoming setup message.

**Table 10-22**

<b>If datafill is</b>	<b>Go to</b>
incorrect	step 17
correct	step 19

17. Modify the incorrect translations. Refer to the *Translations Guide*.
18. Determine if the call will complete.

**Table 10-23**

<b>If the call</b>	<b>Go to</b>
completes	step 20
does not complete	step 19

19. For further assistance, contact the personnel responsible for the next level of support.
20. You have completed this procedure.





---

# 11 User interface

---

This chapter describes the user interface associated with ISDN PRI, including information about:

- MAP level hierarchy
- menu MAP commands
- unlisted MAP commands
- MAP level diagrams
- XMS-based peripheral module (XPM) status indicators
- trunk status indicators
- carrier status indicators
- D-channel status indicators
- messages

*Note:* Though the commands and status indicators at the PM level apply to all peripherals in the office, the descriptions that follow describe the ISDN PRI XPMs, the DTCI and the LTC. For simplicity, references to XPM include XPM PLUS.

The user interface can vary in appearance. Some MAP levels and commands are available only when specific hardware and/or software is provisioned.

## MAP level hierarchy

Figure 11-1 illustrates the MAP hierarchy for ISDN PRI maintenance. The maintenance levels for PRI appear in the figure with bold lines.

Figure 11-1 ISDN PRI MAP sublevels

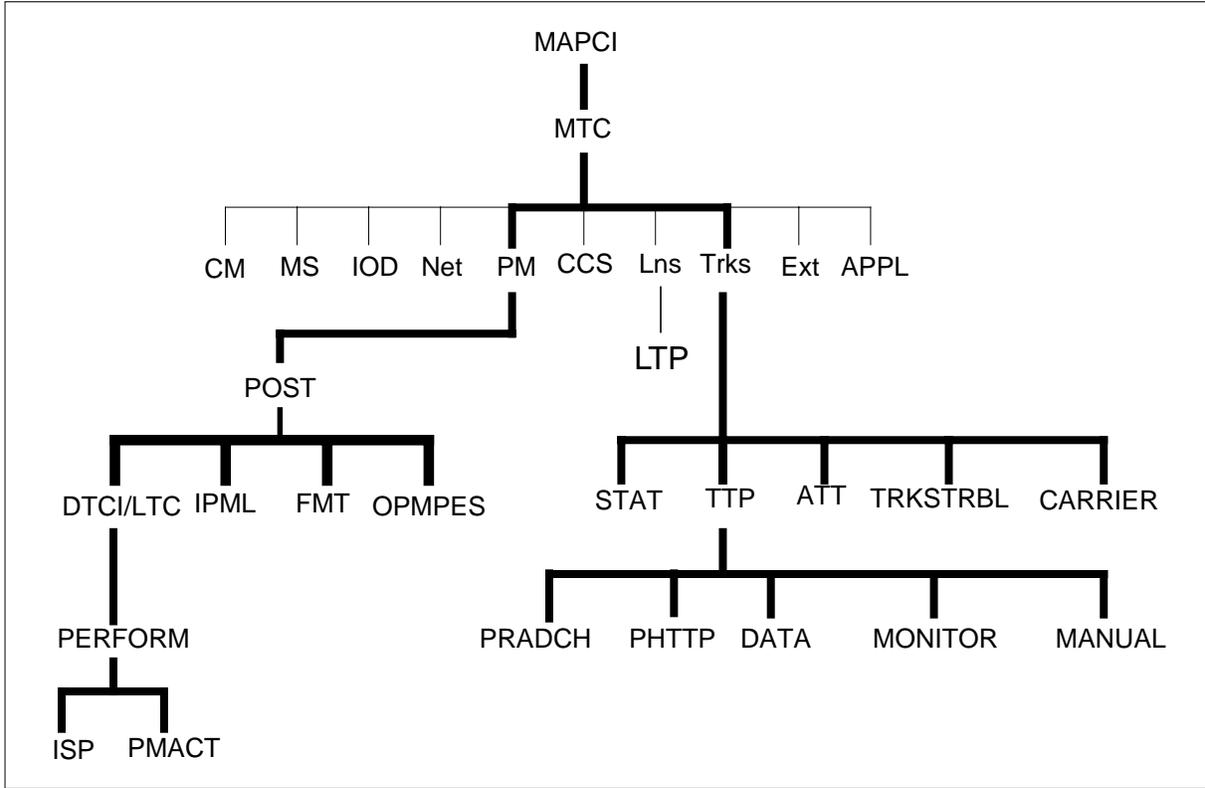

## Commands

This section lists and describes ISDN PRI menu MAP commands and unlisted MAP commands.

### Menu MAP commands

Table 11-1 lists all the ISDN PRI menu MAP commands.

Table 11-1 Menu MAP commands (Sheet 1 of 8)

Command	Level	Description
ATT	TRKS	Accesses the automatic trunk testing (ATT) level.
BERT	DATA	Runs the bit error ratio Test (BERT) between offices.
BTERM	DATA	Registers the type of termination that is set up in the far-end office for the duration of the BERT trunk test. Also displays the termination, or cancels (resets) the registry of the termination.

Table 11-1 Menu MAP commands (Sheet 2 of 8)

Command	Level	Description
BSY	DTCI LTC	Changes the state of the posted DTCI or LTC to manual busy (ManB).
	TTP	Sets the currently posted trunk circuit to manual busy, installation busy, or system busy.
CARRIER	TRKS	Accesses the trunk carrier (CARRIER) level.
CKT	TTP	Connects the specified trunk circuit to the circuit in the control position.
CKTINFO	TTP	Displays information specific to a trunk circuit.
CKTLOC	TTP	<p>Displays the physical location of the trunk circuit in the control position.</p> <p>This command displays</p> <ul style="list-style-type: none"> <li>• the location and its maintenance and transmission data</li> <li>• the floor, row, bay, or shelf location of the PM connected to the trunk in the control position</li> <li>• additional information for packet trunks (X75 and packet PRI)</li> </ul> <p>This information includes details and states for the associated digital trunk controller (DTC), network interface unit (NIU), X.25/X.75 link interface unit (XLIU) channel bus (C-BUS), and speecon connection. This command is available at the TTP and the PHTTP sublevel.</p>
CKTMON	MONITOR	Turns the trunk circuit monitor feature on or off.
CLRALM	TRLSTRBL	Clears the alarm associated with the call processing or maintenance buffers for a trunk group, and resets the failure counters. This command also resets the attempt counter for the call processing buffer.
CLRBUF	TRKSTRBL	Clears the call processing or maintenance buffers for the specified trunk group.
CONNECT	PRADCH	Connects DTA test equipment to a PRI D-channel for monitoring PRI protocol messages.
CONT	PRADCH	Runs a continuity test on the posted D-channel.

**Table 11-1 Menu MAP commands (Sheet 3 of 8)**

<b>Command</b>	<b>Level</b>	<b>Description</b>
CREATESET	TRKSTRBL	Creates a list of the trunk troubles recorded in the call processing or maintenance buffers.
DELMAN	ATT	Deletes manual test entries for a specified trunk group.
DISP	DTCI LTC PM TRKSTRBL	Displays a list of trunks, carriers, or XPMs in a specified state, or a summary of diagnostic failures.
DISPGRP	STAT TKGRP	Displays information on specified trunk groups.
EQUIP	PRADCH	Reserves, queries, and releases DTA monitor equipment for testing two DS-0 channels on a PRI trunk. To use this option, provision the DS-0 channels for 64-kbits/s clear transmission.
FRLS	MONITOR	Forces the call processing busy (CPB) trunk circuit in the control position to manual busy. If another trunk circuit is connected to the circuit in the control position, the connection is released.
HALTMAN	ATT	Stops all automatic trunk testing.
HCPYGRP	STAT TKGRP	Continuously displays or prints information on trunk groups.
HOLD	TTP	Places the trunk circuit in the control position in the first available hold position.
HSET	MANUAL	Connects a headset to the trunk circuit in the control position by a headset trunk.
JACK	MANUAL	Connects one of the TTP test jacks to the control position.
ITEM	STAT TKGRP	Displays data on trunk circuits within a trunk group, and accesses the STAT TRKS level.
LEVEL	TTP	Accesses the TTP sublevel display.
LISTALM	TRKSTRBL	Lists the trunk groups that have an active alarm. This information is retrieved from the call processing and maintenance buffers.
LISTMAN	ATT	Displays data about manual tests.

Table 11-1 Menu MAP commands (Sheet 4 of 8)

Command	Level	Description
LISTSET	DTCI LTC	Lists the discrimination numbers of the XPM types in the posted set.
LSTCLLI	ATT	Displays a list of all the scheduled automatic trunk circuit tests and associated data for a trunk group.
LSTSTOP	ATT	Lists all inactive entries in the scheduling table ATTSCHED.
LSTWAIT	ATT	Lists the active and waiting tests.
LOADPM	DTCI LTC	Loads the peripheral program files into the posted DTCI or LTC.
LOOPBK	PRADCH	Sets, removes, or checks the status of the loopback point for the posted D-channel.
	PHTTP	Sets or removes a loopback on a posted packet trunk. This command is valid at the X75TTP level (pre-NA011) and the PHTTP level (post-NA011). Use this command to perform maintenance on the X75 and the packet trunks before you perform the continuity test on the trunks.  Valid on X75 and packet PRI trunks. An error message displays on the PHTTP MAP level if operating company personnel set a loopback on any trunks other than an X75 or packet PRI trunk.
LOSS	MANUAL	Measures the received signal loss of the trunk circuit in the control position.
MONLINK	MONITOR	Sets up a connection between the headset of the TTP communications device and the trunk circuit that links to the circuit in the control position. The MONLINK command supports digital monitoring with digital test equipment.
MONPOST	MONITOR	Sets up a connection between the headset of the TTP communications device and the trunk circuit in the control position. The MONPOST command supports digital monitoring with digital test equipment.
MONTALK	MONITOR	Establishes a three-party conference trunk circuit connection among the circuit in the control position, the circuit linked to it, and the headset of the TTP. The connections are set up through a three-port conference circuit.

Table 11-1 Menu MAP commands (Sheet 5 of 8)

Command	Level	Description
NEXT	Most PM and TRKS levels	Moves the next trunk or XPM in the posted set into the control position.
NEXTGRP	STAT TKGRP	Displays data on the next 12 trunk groups of a group type and alarm.
NOISE	MANUAL	Measures noise by connecting the trunk circuit in the control position to the noise-measuring circuit. The measurement displays continually update.
OFF L	DTCI LTC	Changes the state of DTCI or LTC to off-line (OffL).
OP	MANUAL	Outpulses a specified number on the trunk circuit in the control position.
PERFORM	DTCI LTC	Accesses the PERFORM level. The PERFORM level displays information about the processors of a posted XPM. The MAP display updates every minute.
PFQUERY	PERFORM	Identifies the XPMs currently undergoing the performance process by XPM type, and number and accesses the ISP level.
PMACT	PERFORM	Accesses the PMACT level and displays the status of activities within the posted XPM. Some examples of the types of activities monitored are as follows: number of peak terminations and originations, average number of peak terminations and originations, number of channels available for call processing, number of channels in use, and the number of processes for the master processor, signaling processor, and ISDN signaling preprocessor (ISP).
POST	Most PM and TRKS levels  PRADCH	Posts one or more trunks, carriers, channels, XPM units, or XPMs for maintenance.  All primary rate access (PRA) B-channels, D-channels, and other trunks, such as Common Channel Signaling 7 (CCS7) and MF, can be posted with this command. Quitting from the PRADCH level to the TTP level clears all the post and hold queues. Originally, the PRADCH level was intended for posting signaling trunks only. The TTP level is not for signaling trunks.

Table 11-1 Menu MAP commands (Sheet 6 of 8)

Command	Level	Description
	TTP level and PHTTP sublevel	Use this command to enter the PHTTP MAP level. The existing X75TTP MAP level is renamed PHTTP to provide an integrated maintenance level for the packet handler trunks. Use the PHTTP MAP level to perform maintenance on the X75 and the packet PRI trunks. The IN PULSE and OUT PULSE fields under the TYPE heading in the MAP display differentiates between the packet PRI and the X75 trunks when an X.25 packet PRI is posted. For X.75, the impulse and outpulse is X7.
POSTISP	ISP	Posts an enhanced ISDN signaling processor (EISP) channel. See PERFORM, PFQUERY.
QSUP	TRKSTRBL	Lists all the trouble types that are suppressed.
QUERYPM	DTCI LTC	Displays information about the posted line XPM, including equipment location, load name, and status.
RESUME	TRKSTRBL	Cancels the suppression of the specified trouble type.
REX	Most PM levels	Performs a routine exercise (REx) test on a XPM unit or XPM.
RLS	TTP	Releases the connection to the trunk circuit in the control position.
RTS	Most PM and TRKS levels	Returns a posted trunk, carrier, XPM unit, or XPM to service.
RUNATT	ATT	Restarts all scheduled ATT or restarts all tests that were stopped by the HALTATT command.
SEIZE	TTP	Seizes a trunk circuit for maintenance action.
SETSTST	ATT	Sets the maximum number of tests that can run simultaneously.
START	ATT	Starts a test sequence on a specified trunk group or restarts only those tests that were stopped with the STOP command. A test always restarts from the beginning, regardless of where in the test sequence it stops.
STAT	TRKS TRKSTRBL	Accesses the trunk group status (STAT TKGRP) level. Accesses the STAT TKGRP level.



Table 11-1 Menu MAP commands (Sheet 7 of 8)

Command	Level	Description
STATUS	PM	Shows the XPM status.
STOP	ISP PMACT ATT	Stops the performance process begun by the STRT command. See PERFORM, PMACT, PFQUERY.  Stops a test sequence on a specified trunk group.
STOPDISP	TRKSTRBL	Stops the periodic updating of the screen that starts using the DISP command.
STOPLOG	ISP PMACT	Stops the performance process begun by the STRTLOG command. See PERFORM, PMACT, PFQUERY.
STRT	ISP PMACT	Starts the timer and the performance testing process. See PERFORM, PMACT, PFQUERY.
STRTLOG	ISP PMACT	Starts generating the XPM logs for the performance testing process. See PERFORM, PMACT, PFQUERY.
SUPPRESS	TRKSTRBL	Causes the specified trouble types to be ignored.
SWACT	DTCI LTC  PRADCH	Switches active and inactive units in the posted DTCI or LTC.  Switches the D1 activity from in-service to lockout and D2 activity from standby to in-service.
TDET	MANUAL	Identifies the tone signal received on the trunk circuit in the control position by connecting the tone detector.
TESTREQ	ATT	Requests a manual test.
TGEN	MANUAL	Sends a tone over the trunk circuit in the control position to a distant office.
TRKSTRBL	TRKS STAT TKGRP	Accesses the trunks trouble (TRKSTRBL) level.
TRNSL	DTCI LTC	Displays the C-side link or P-side link information.

**Table 11-1 Menu MAP commands (Sheet 8 of 8)**

Command	Level	Description
TST	Most PM and TRKS level TTP PHTTP	Tests the posted trunk, carrier, channel, link, card, XPM unit, or XPM. TST with X.25 performs an internal continuity test on a PRI trunk.
TTP	TRKS	Accesses the trunk test position (TTP) level.

### Unlisted MAP commands

Table 11-2 lists all the ISDN PRI unlisted MAP commands.

**Table 11-2 Unlisted MAP commands (Sheet 1 of 2)**

Command	Level	Description
ABTK	DTCI LTC	Cancels all active maintenance action, including loading, on the posted LTC.
BERTTIME	DATA	Specifies the duration of the bit error ratio test (BERT).
CPSTAT	PM	Displays the software processing status for a given node number of a XPM.
CREATE_TTP	TRKS TTP	Creates a new trunk test position (TTP).
DATATTP	TRKS TTP	Accesses the DATA-level menu.
DELETE_TTP	TRKS TTP	Deletes a trunk test position (TTP).
FRLS	TRKS	Forces the call processing busy (CPB) trunk circuit in the control position to manual busy. If another trunk circuit connects to the circuit in the control position, the connection is released.
LDPMALL	PM	Simultaneously loads or reloads more than one XPM.
LOADFW	TRKS TTP	Loads firmware to a multiline test unit (MTU) or to a digital test unit (DTU) that is attached to a maintenance trunk module (MTM).
LOADNOTEST	DTCI LTC	Performs the same function as the LOADPM commands, but omits the read-only memory (ROM) test.

**Table 11-2 Unlisted MAP commands (Sheet 2 of 2)**

<b>Command</b>	<b>Level</b>	<b>Description</b>
NEXT	PM	Displays status information for the next XPM in the posted set.
PATCHXPM	DTCI LTC	Loads new or changed software for a single change supplement (SCS).
PHTTP	CI	Enters the PHTTP MAP level to perform maintenance on the X75 trunks and packet on PRI.
PMLOADER	PM	Queries the cause of the PMLOAD alarm or forces an audit that reattempts autoloading.
REPEAT	TRKS	Repeats a test or a sequence of tests.
WARMSWACT	DTCI LTC	Performs a warm SWACT.
XPMLOGS	DTCI LTC	Allows logs to generate from the XPM and reports SWERRS.
X75TTP	TTP	Enters the PHTTP MAP level instead of the X75TTP MAP level. This level is used as an integrated MAP level for maintaining packet handler trunks. Maintain both X75 and packet PRI trunks at this level.

## MAP level diagrams

The following section provides information on PM level and TRKS level menu commands as they appear on the MAP display. Figure 11-2 shows the ISDN PRI-related PM levels and menu commands. Figure 11-3 shows the ISDN PRI-related TRKS levels and menu commands.

Figure 11-2 PM level commands

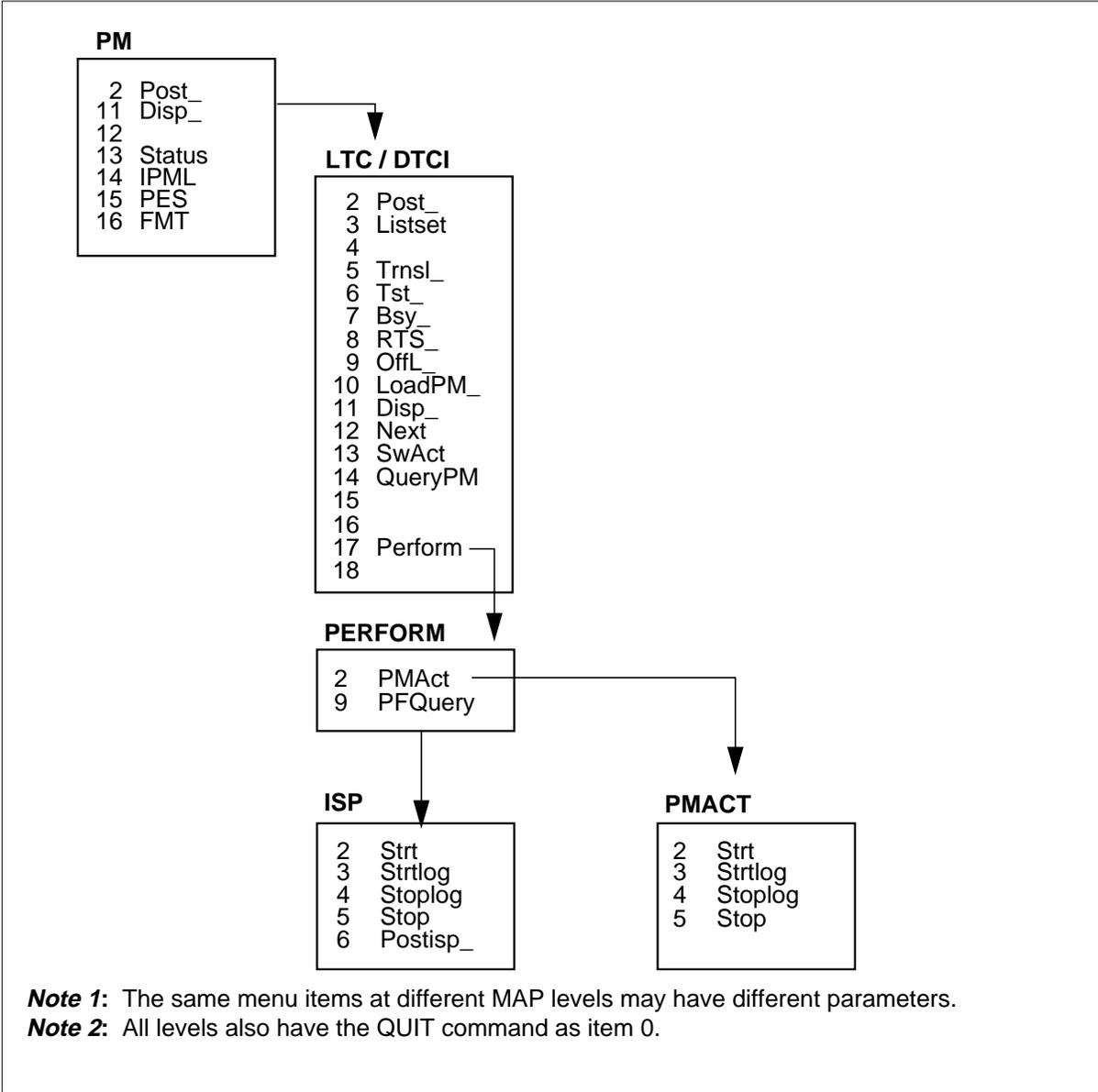

Figure 11-3 TRKS-level commands

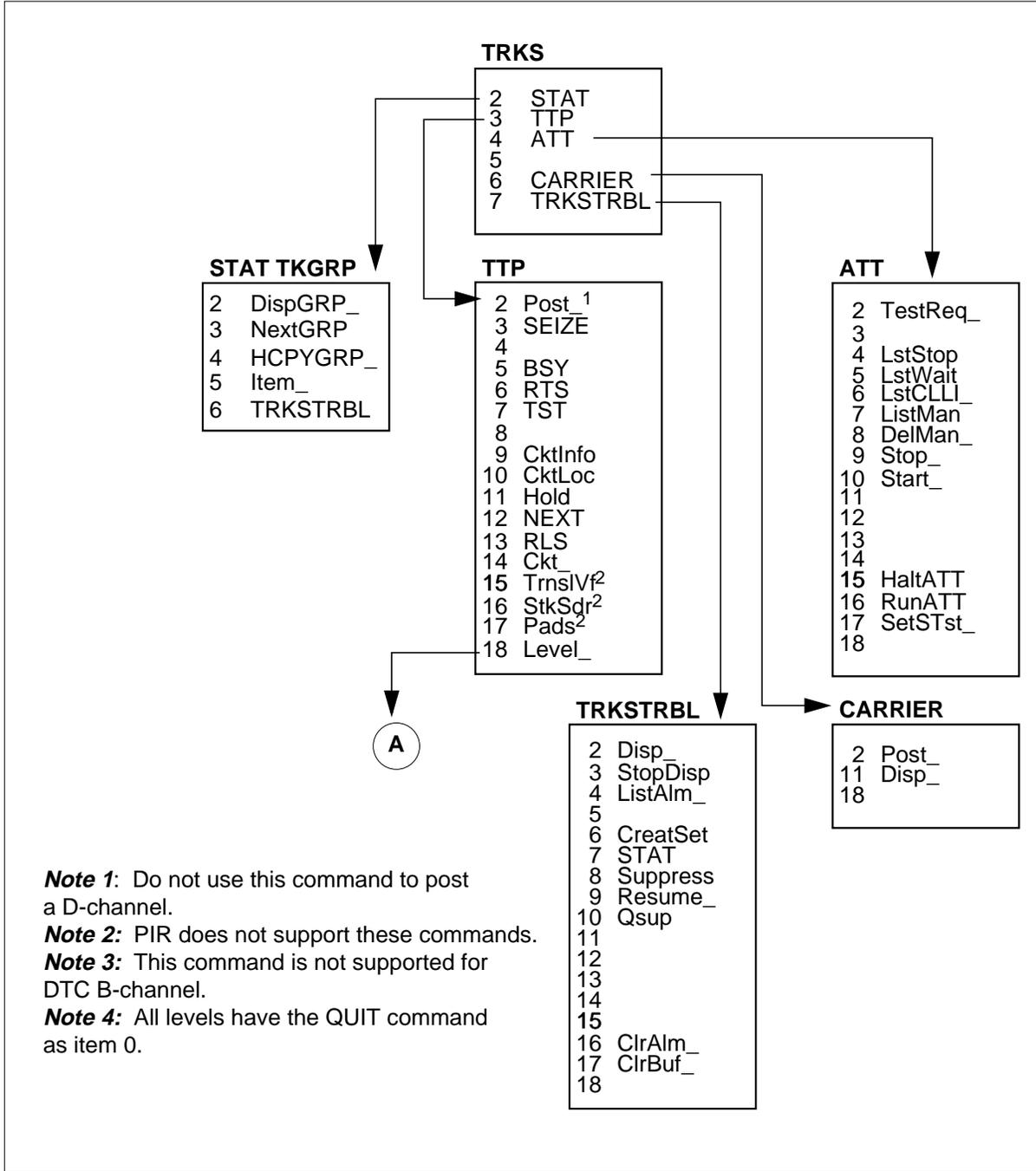
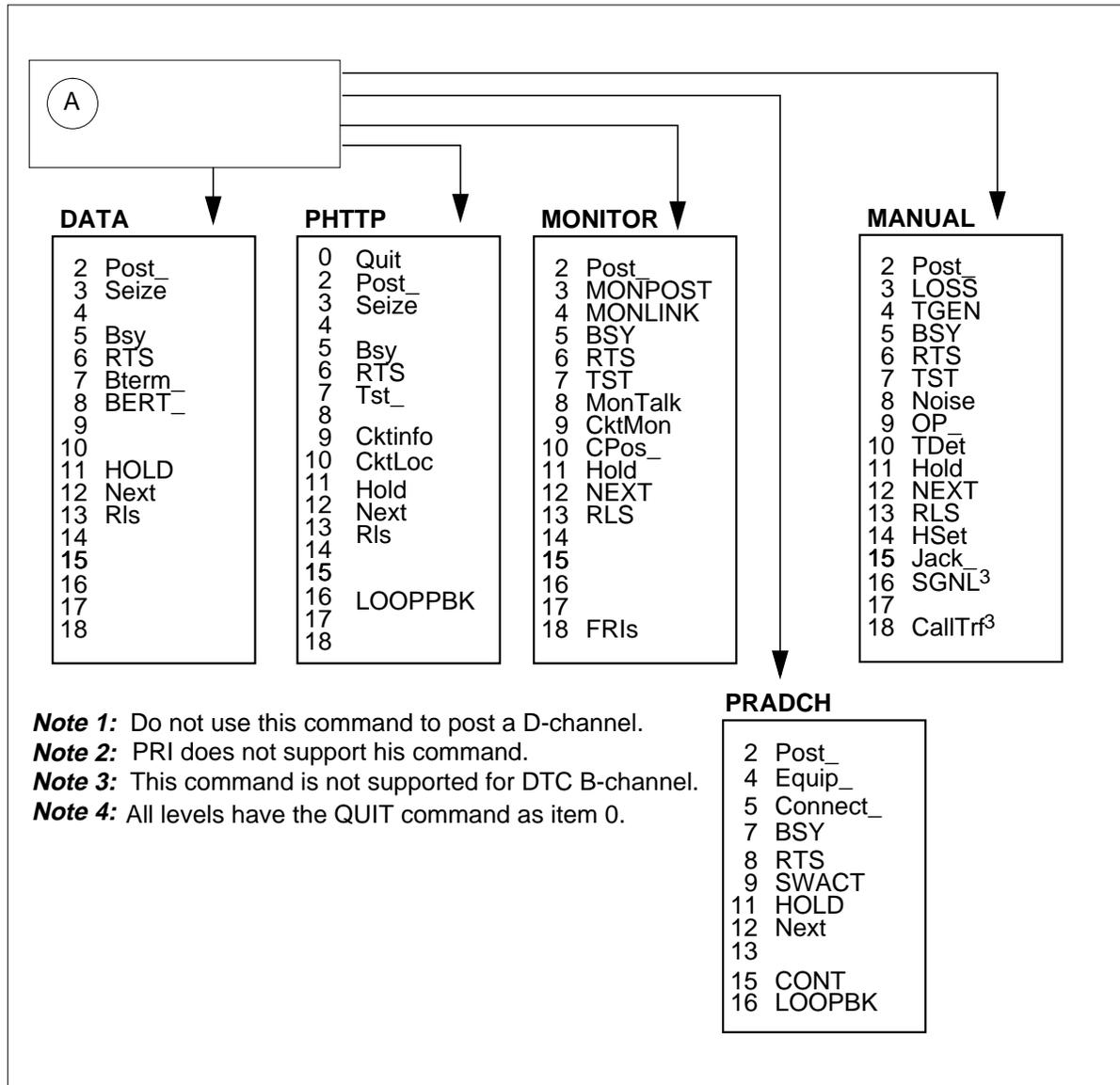

Figure 11-4 TRKS level commands



## Status indicators

This section describes ISDN PRI XPM, trunk, carrier and D-channel status indicators. Table 11-3 lists and describes the DTCI and LTC states.

**Table 11-3 DTCI and LTC states**

State	Description
CBsy	<i>Central-side (C-side) busy</i> There is no access to the XPM from the network. One or more links from the network to the XPM are out of service.
InSv	<i>In service</i> The XPM is in service.
IsTb	<i>In-service trouble</i> A fault exists on the XPM, the fault does not affect service.
ManB	<i>Manual busy</i> Manual maintenance is in progress.
OffL	<i>Off-line</i> The XPM is off-line.
SysB	<i>System busy</i> The system detected an XPM fault and removed the XPM from service.

Table 11-4 lists and describes the DS-1 trunk states.

**Table 11-4 DS-1 trunk states (Sheet 1 of 3)**

State	Description
CBSY	<i>Central-side (C-side) busy</i> The carrier is not available for service because the associated C-side node is busy.
CPB	<i>Call processing busy</i> The trunk circuit is carrying traffic.
CPD	<i>Call processing deload</i> The trunk circuit is carrying traffic and is available for maintenance once call processing completes.
CFL	<i>Carrier failure</i> The carrier failed and the trunk is removed from service.
DEL	<i>Deload</i> The trunk circuit that was previously CPD is now available for maintenance.

Table 11-4 DS-1 trunk states (Sheet 2 of 3)

State	Description
DFL	<i>D-channel failure</i> The system removed the D-channel removed from service.
DMB	<i>D-channel manual busy</i> The D-channel is manually removed from service.
IDL	<i>Idle</i> The trunk circuit is available for service.
INB	Installation busy The trunk circuit is installed but is not in service.
INI	Initializing All trunks are placed in this state after a cold or reload restart.
INSV	<i>In service</i> The carrier is in service.
ISTB	Inservice trouble The trunk is in service but the system detects faults on the trunk circuit.
LO	Lock out The D-channel associated with the trunk is in service but layer 3 cannot communicate with the far end for one of the following reasons: <ul style="list-style-type: none"> <li>• layer 2 is out of sync</li> <li>• layer 2 is in sync but no logical link is established</li> <li>• layer 3 is not responding to a restart or release</li> </ul>
MANB	Manual bust The carrier is manually removed from service for maintenance.
MB	Manual busy The trunk is manually removed from service for maintenance.
NEQ	Not equipped The hardware or datafill associated with the trunk is not provisioned.
NMB	Network management busy Network Management removed the trunk from service.
OFFL	Off-line The carrier is placed off-line for maintenance and is unavailable for service.



**Table 11-4 DS-1 trunk states (Sheet 3 of 3)**

<b>State</b>	<b>Description</b>
PBSY	Peripheral side (P-side) busy The carrier is not available for service because the associated P-side node is busy.
PMB	Peripheral manual busy The trunk circuit is not available for service because the associated XPM is out of service.
RMB	Remote made busy Either the far end or near-end office removed the trunk from service.
SZD	Seized The posted trunk is seized for maintenance.
SB	<i>System busy</i> The system detects a fault on the trunk circuit and removes the trunk circuit from service.
SYSB	<i>System busy</i> The system detects a fault on the carrier and removes the carrier from service.
UNEQ	<i>Unequipped</i> The hardware or datafill associated with the carrier is not provisioned.

Table 11-5 lists and describes the D-channel states.

**Table 11-5 D-channel states (Sheet 1 of 2)**

<b>State</b>	<b>Description</b>
CFL	<i>Carrier fail</i> The the system removes the carrier on which the D-channel is provisioned from service.
LO	<i>Lockout</i> The D-channel is in lockout because of a logical link or hardware failure.
INB	<i>Installation busy</i> The D-channel is installed but is not in service.
INI	<i>Initializing</i> The D-channel is initializing.

**Table 11-5 D-channel states (Sheet 2 of 2)**

<b>State</b>	<b>Description</b>
INS	<i>In service</i> The D-channel is in service and available for call processing.
MB	<i>Manual busy</i> The D-channel is manually from service for maintenance.
PMB	<i>Peripheral manual busy</i> The maintenance personnel removes the peripheral is removed from service, causing the D-channel to PMB.
RNR	Remote not responding Layer 3 at the far end is not responding although layer 2 is established and ready.
RST	Restart transmitted A restart message is sent to the far end.
STB	<i>Standby</i> The D-channel is in the multiple frame state established at layer 2, but is not carrying any layer 3 call-control messages on the logical data link.
WAI	Wait The D-channel is in standby.

## Messages

Release NA011 introduces error messages and information messages associated with commands. If the operating company personnel try to issue a command that is invalid for a PKT PRI trunk at the TTP level or sublevels, the following error message displays:

**Figure 11-5 Error message display**

```
Command not allowed with PKT PRI trunks.
```

The following table lists the error messages and information messages that display when using the commands as listed.

**Table 11-6 Descriptions of error messages (Sheet 1 of 3)**

Command	Message	Description
LOOPBK	Failed, Posted CKT is neither X75 nor a PKT PRI trunk.	Displays on the MAP terminal when operating company personnel try to set a loopback on trunks other than an X75 or packet PRI trunk.  Action: Post an X75 or packet PRI trunk to perform loopback set, remove, or query.
	Loopback set on the trunk. Use LOOPBK REMOVE at PHTTP level.	Displays on the MAP terminal when operating company personnel try to issue a valid command (other than the Post or Next command) on a packet PRI trunk on which a loopback was previously set by other operating company personnel.
POST D	<PKT PRI DN> is a PKT PRI DN and will not be posted.	Generates when operating company personnel try to post a packet PRI non-shared DN at the LTP MAP level.  <b>Note:</b> The PKTPRI DN/LTID is associated with a CLLI rather than a LE. It is not maintained at the LTP level.
	The PMD Calltype of <PKT PRI shared DN> is PKT PRI and will not be posted.	Generates when operating company personnel try to post a packet PRI shared DN at the LTP level.  Action: Use QPHF LTID <ltid>. This action displays CLLI and member. Use CLLI and member to post at the PHTTP level.
POST DK	This is a PKT PRI DN and will not be posted.	Generates when operating company personnel try to post a packet PRI non-shared DN and the associated key at the LTP level.  <b>Note:</b> The PKTPRI DN/LTID is associated with a CLLI rather than a LEN. It is not maintained at the LTP level.  Action: Use QPHF LTID <ltid>. This action displays CLLI and member. Use the CLLI and member to post at the PHTTP level.

Table 11-6 Descriptions of error messages (Sheet 2 of 3)

Command	Message	Description
POST H	The PMD Calltype is a PKT PRI DN and will not be posted.	Generates when operating company personnel try to post a packet PRI shared DN and the associated key at the LTP level  Action: Use QPHF DN and post at the PHTTP level.
	The PKT PRI Hunt members will not be posted.	Generates when operating company personnel try to post a packet PRI hunt group at the LTP level.  <b>Note:</b> The PKTPRI DN/LTID is associated with a CLLI rather than a LEN. It is not maintained at the LTP level.  Action: Use QPHF LTID <ltid>. This action displays the CLLI and member. Use the CLLI and member to post at the PHTTP level.
POST LT	The LTID is not mapped to a loop.	Generates when operating company personnel try to post a packet PRI LTID at the LTP level. A packet PRI LTID maps to a CLLI rather than a LEN.  <b>Note:</b> The PKTPRI DN/LTID is associated with a CLLLI rather than a LEN. It is not maintained at the LTP level.  Action: Use QPHF LTID <ltid>. This action displays the CLLI and member. Use the CLLLI and member to post at the PHTTP level.
TST	Ext cont test is invalid on PKT PRI trunks.	Displays when operating company personnel try to perform an external continuity test on a packet PRI trunk.
	TST command diag invalid with PKTPRI. Use X25i option.	Displays when operating company personnel try to perform a TST command on a packet PRI trunk.
	Test passed.	Displays on the MAP terminal when the internal continuity test successfully complete. The display indicates on which trunk member the test was performed.

**Table 11-6 Descriptions of error messages (Sheet 3 of 3)**

<b>Command</b>	<b>Message</b>	<b>Description</b>
	Test failed.	Displays on the MAP terminal when the internal continuity test on the packet PRI trunk fails. The display indicates on which trunk member the test was performed.
	Test aborted.	Displays on the MAP terminal when the internal continuity test on the packet PRI trunk does not complete because of a software failure. The display indicates on which trunk member the test was performed.
X75TTP	Control transferred to PHTTP level.	Displays when operating company personnel issue the X75TTP command at the TTP level.

---

# 12 Trouble isolation and correction methods

---

This chapter provides general methods and information about PRI trouble isolation and correction. The material in this chapter falls into the following categories:

- test tools, such as TRAVER, DISPCALL, PMIST, PMDEBUG, and CallTrak
- PRI hardware and software maintenance model
- general troubleshooting procedure for PRI
- troubleshooting initial installation and in-service troubles
- D-channel loopback for troubleshooting
- DS-1 maintenance signaling notes
- techniques for PM troubleshooting
- troubleshooting PRI datafill
- troubleshooting PRI call processing and protocol
- digital test access

The “Troubleshooting chart” chapter provides a chart that relates specific trouble symptoms to possible causes. Isolation and correction of PRI troubles requires you to consider the non-DMS equipment that completes the path from the DMS PM to the next node. This equipment includes T1 spans and PBXs from different manufacturers.

For more information about the user interface (MAP) commands in this chapter, refer to the “User interface” chapter.

## Test tools

The following section describes software tools you can use to troubleshoot PRI problems. The translation verification (TRAVER) utility is a standard utility

provided for the DMS-100 switch. The following test tools are optional and may or may not be present in your office:

- display call (DISPCALL)
- peripheral module intercept system test (PMIST)
- peripheral module debug (PMDEBUG)
- CallTrak

The effective use of these optional test tools depends on a high level of understanding of the DMS hardware and software. The incorrect use of some of these tools can cause service disruption.

### **Translation verification**

the translation verification (TRAVER) tool checks that PRI translation and datafill routing are consistent and correct. TRAVER simulates the processing of a telephone call in software, and displays the route to the destination, which can be a line, trunk, or operator position.

### **Display Call**

Display call (DISPCALL) is a low-level internal diagnostic tool that captures and displays call condense blocks (CCB), call data block (CDB), message buffers, and agent data for dead calls or calls being held for trouble analysis. You can use DISPCALL to analyze AUDIT log reports.

For more information about using DISPCALL, refer to the *Display Call (DISPCALL) User Guide*, TAM-1001-003.

### **Peripheral module intercept system test**

Peripheral module intercept system test (PMIST) intercepts, records, and dispatches messages that flow between the central control (CC) and peripheral module (PM). Examine these messages to determine if the CC and PM are processing each other's messages correctly.

PMIST performs the following functions:

- records I/O messages between CC and PM
- inserts user-specified I/O messages
- performs node-to-name translations
- stores messages in a file

For more information about using PMIST, refer to the *Peripheral Module Intercept System Test User Guide*, TAM-1001-007.

---

## Peripheral module debug

Peripheral module debug (PMDEBUG) is a low-level internal diagnostic tool you can use to debug peripheral modules. PMDEBUG is extended to include tracing and simulating ISDN Q.931 messages.

PMDEBUG performs the following functions:

- displays CSM, trap, and SWERR information
- displays channel data
- performs internal PM diagnostics
- performs a call trace
- communicates with the peripheral through monitor commands

Use the following commands for debugging time-critical signaling processor (SP) functions:

- A/B bit scanning
- time-switch control
- CSM transmit and receive
- network module message transmit and receive

Use the following commands for debugging the master processor (MP) call processing functions:

- digit collection
- channel assignment
- CC message interpretation
- PM message interpretation

For more information about using PMDEBUG, refer to the *PMDEBUG User Guide*, TAM-1001-004.

## CallTrak

CallTrak provides the ability to trace calls from one or more terminals, either line or trunk, by selecting the originating terminal of the call. CallTrak contains individual tools used to collect and display data. CallTrak supports the tools PGMTRACE, MSGTRACE, and TIMECALL. PGMTRACE is based on the existing tool CALLCT, and provides procedures for call tracing and for the call process CALLCP. MSGTRACE is based on PMIST, and provides incoming and outgoing message monitoring for all messages to and from a traced call. TIMECALL provides a listing of the call events and the real-time cost of those events. TIMECALL also provides the total real-time cost for the call.



CallTrak is a call-processing specific tool, you can use to collect data for call-processing applications. CallTrak does not replace the CALLCT and PMIST tools.

For more information about using CallTrak, refer to the *CallTrak User Guide*, TAM-1001-012.

## **PRI maintenance model**

This section presents a maintenance model for PRI. The model defines terms and shows relationships among PRI elements. The model has two the following sub-models:

- the hardware model (the physical D- and B-channel connections)
- the software or call control model (logical D-channel operation)

### **Hardware model**

The hardware model is shown in Figure 12-1. Subscriber A represents the entity at the next node that initiates or terminates the call. This entity can be a user who places a call on a telephone, or a computer that places a call through a direct connection to the adjacent node. The adjacent node can be any entity that can handle PRI, such as a PBX or a computer.

The adjacent node includes the connection to the T1 carrier through a customer interface (CI), which can be a data service unit or a customer service unit (DSU/CSU).

In this model, the call completes to a subscriber whose line or trunk terminates on a PM different from the PM that supplies PRI at the DMS-100 switch.

The five sections of the PRI physical model include the following:

- the DMS-100 switch that includes the PM (DTCI or LTC for PRI)
- the DS-1 link between the PM and the adjacent node
- the T1 span from the office repeater bay
- the facility
- the adjacent node

Figure 12-1 PRI hardware model

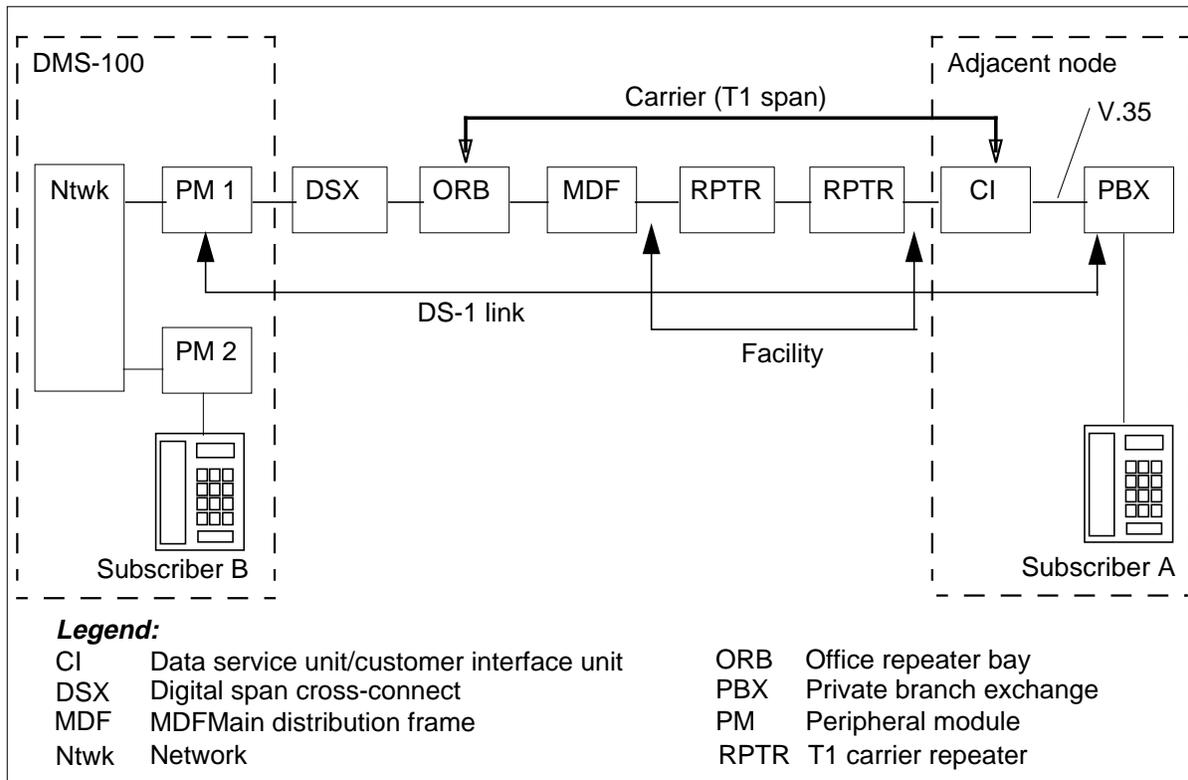

### Software or call control model

The second part of the PRI maintenance model, shown in Figure 12-2, is the call processing model that relates the channels and call processing elements. In the model, the D-channel from the next node terminates at the ISDN signal processor (ISP) of the PM. Call setup data is extracted from the Q.921/Q.931 messages by the EISP or ISP and is transferred to the unified processor (UP) or signaling processor (SP) and master processor (MP). From the UP or MP, call data is sent to the network for routing. When call processing and routing are complete, the B-channel connects through the PM and network to the destination.

Figure 12-2 Call processing model

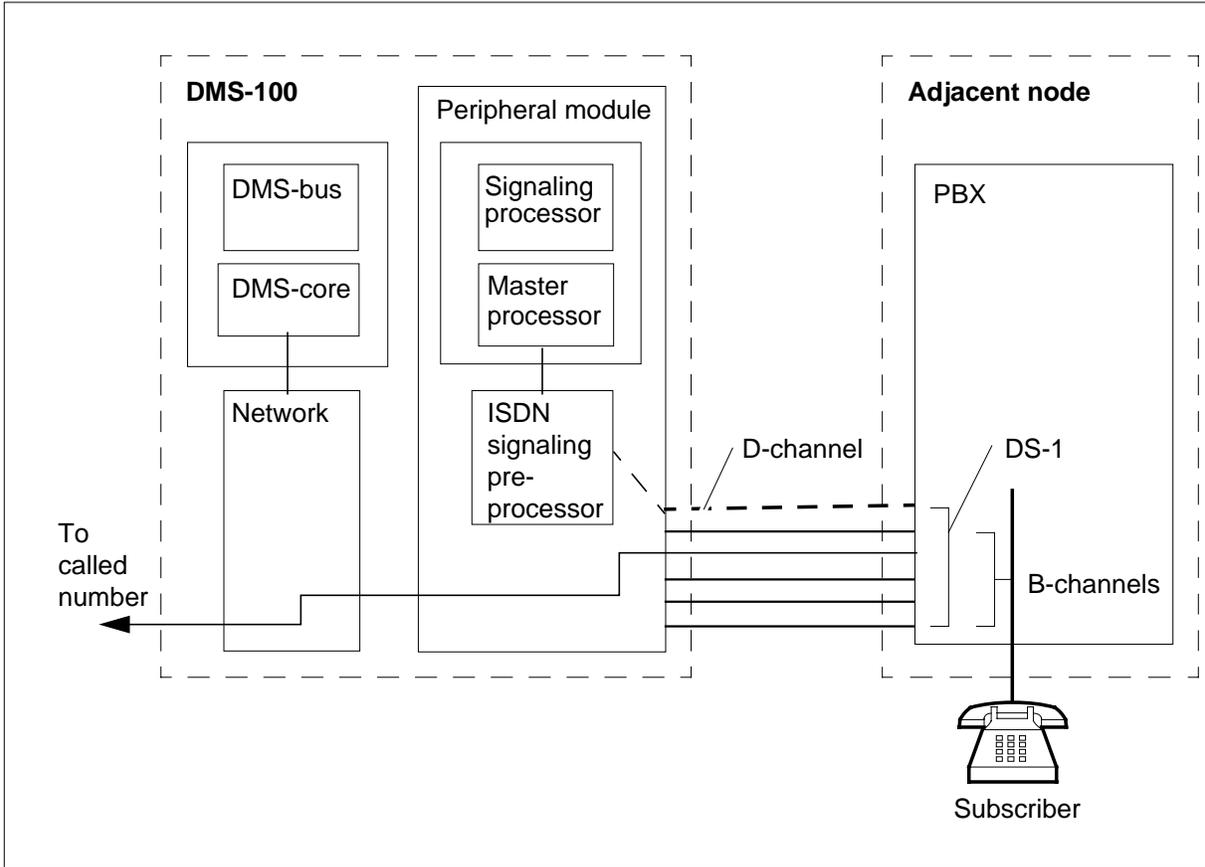

### General troubleshooting procedure

This section presents a procedure you can follow to isolate a problem with PRI. A summary of the steps are in Table 12-1.

The office equipment (OE) list sets out the components of an individual circuit, and its logical and physical interconnections. The method to obtain this OE list depends on your company's operational support system (OSS).

The primary tool in use to isolate a physical fault in the DS-1 path is the loopback. You can also use digital test access on the D-channel to isolate protocol errors. Both tools are described in more detail later in this chapter.

**Table 12-1 Troubleshooting steps**

Step	Action	Notes
1	Check for alarms	Refer to the <i>Alarm and Performance Procedures</i> for clearing PM alarms.  Refer to the <i>Alarm and Performance Monitoring Procedures</i> for clearing TRK alarms.
2	Check logs	Use LOGUTIL commands OPEN and BACK to search for applicable logs (PM, ISDN, TRKS).
3	Verify the OE list	Use QUERY to check the connections specified in the OE list.
4	Post components	For DS-1 status use TRKS;CARRIER;POST for the PM use PM;DTCI or LTC.
5	Set loopbacks and perform internal or external continuity tests	Refer to the <i>Trouble Locating and Clearing Procedures</i> for procedures on how to perform internal or external continuity tests.
6	Look at OMs	Use OMSHOW.
7	Monitor protocol	Use digital test access (DTA) to monitor the protocol.

## Some notes on troubleshooting

The following material include general and miscellaneous notes that you can use to help isolate some PRI troubles.

### Initial installation troubles

Initial installation trouble occurs when a PRI is put into service for the first time. Although everything in the chain of service is suspect, two primary causes of initial installation trouble are the following:

- datafill
- T1 span

### Datafill problems

A common problem is the datafill for integrated service access (ISA) and the role of information elements NPI/NSF. For more details on ISA, refer to page 16.

### **T1 span problems**

A common problem related to the DS-1 link is that facility line coding (ZCS or B8ZS) is not the same over the entire T1 span.

### **In-service troubles**

Field experience indicates the most likely PRI failure is in the T1 span. Because of the different types of equipment used in T1 spans, a standard procedure cannot be given. You must isolate and correct T1 faults using the local operating company procedures.

Failures also occur when a feature or function is in use for the first time on a circuit that is providing satisfactory PRI service. This type of failure is usually related to datafill.

### **D-channel loopback**

The D-channel can loop back to perform both internal and external continuity tests. Continuity tests must be run from the PRADCH level of the MAP. For information about how to access the PRADCH level, refer to the “User interface commands” chapter. The CONT command sets, removes, and reports the status of the loopback point for the posted D-channel.

*Note:* Before you invoke the CONT command, place the D-channel in the manual busy state.

### **DS-1 maintenance signaling notes**

DS-1 maintenance signaling is done in-band in the superframe (SF) format, or in the data link of the extended superframe (ESF) format. Both support the following signals

- Remote alarm indicator (RAI) is the yellow alarm sent to the remote end, indicating a loss of incoming data from the remote end. The signal has a minimum duration of 1 s, and lasts for the duration of the outage. For SF, the RAI signal sets bit two to zero (0). For ESF, the RAI signal consists of alternating hexadecimal digits FF and 00.
- Alarm indication signal (AIS) is the blue alarm that indicates the loss of an originating signal or other service disruption. The signal is a continuous unframed binary one (1) digit. AIS can also indicate a loss of network synchronization.
- Loopback signaling is done in-band using framed pulse patterns: activate is 5 s of 00001, and deactivate is 5 s of 001.

To support maintenance function on the DS-1 facility, ESF incorporates a block error detection scheme (CRC-6) and a data link. Errors on the DS-1 can be detected by

- cyclic redundancy check (CRC)
- bad framing pattern or loss of framing
- non-B8ZS bipolar violations (BPV)
- controlled slips (if customer interface is in a synchronized network)
- replication or deletion of a frame

The CI reports the error parameters each second over the data link.

### **Other DS-1 issues**

The DS-1 link can be

- dead (no continuity, no loopback possible)
- low quality as reported by service limits being exceeded, or from BERTs (bipolar violations, framing errors, CRC errors)

### **Some notes on the DS-1 card**

The information below can help in working with the DS-1 card:

- Activities that involve the DS-1 card are pegged in OM group DS1CARR.
- Changes to DS-1 parameters in table CARRMTC do not take effect until the CC updates the PM. An audit for static data mismatch occurs every time the PM is manually or automatically tested or returned to service. If the audit detects changes (a mismatch), the PM is reloaded.
- The state of a carrier (DS-1) is deferent from the state of the individual trunks (DS-0s).

### **Causes of DS-1 line errors**

Some common causes of line data errors are

- outside electrical interference
- line repeaters
- office repeaters
- DS-1 interface card
- adjacent node

### Testing for DS-1 line errors with BERT

Use bit error rate tests (BERT) to test for line errors. You can invoke BERTs from MAPCI;MTC: TRKS;TTP;LEVEL DATA. Table 12-2 summarizes the commands you can use to conduct a BERT.

**Table 12-2 Data level commands for testing for line errors**

Command	Description
POST	Gains ownership of the trunks to be tested
SEIZE	Seizes the trunk to be tested
BSY	Places the trunk in the out-of-service state.
RTS	Returns the trunk to service
BTERM	Registers far end termination type
BERT	Controls the actual BER test
HOLD	Puts the trunk in first available hold position
NEXT	Places another trunk in the control position
RLS	Returns the trunk to service
BERTTIME	(Nonmenu)sets the test duration

Before beginning the BERT, the trunk you want to test must meet the following conditions:

- reserved for testing with the POST command
- busied out with the BSY command
- far-end termination specified with BTERM command

Table 12-3 summarizes how to use the BERT commands.

**Table 12-3 BERT command sequence (Sheet 1 of 2)**

Command	Description
BERT START <speed> <pattern>	Starts the test. <speed> is 56 or 64. <pattern> is P511 or P2047
BERT INJECT <error_bits>	Inject error bits into the test pattern
BERT RESET	Resets the test results
BERT QUERY TEST	Display trunks on which tests are active

**Table 12-3 BERT command sequence (Sheet 2 of 2)**

Command	Description
BERT QUERY RESULT	Display all the test results
BERT STOP	Stop the test

**NT6X50AB DS-1 card maintenance notes**

You can check the DS-1 card options described below using the MAPCI CARRIER level command DISP. Notice that the options selected for a DS-1 link are effective only after the link is returned to service.

The NT6X50AB is a general replacement for the NT6X50AA card on both the C-side and P-side of an XPM. The AB version of the card provides

- extended super frame format (ESF)
- binary 8 zero substitution (B8ZS)
- AIS

The AA and AB versions of the card support the following functions:

- frame format, super frame (SF)
- zero code suppression (ZCS)
- bit error ratio (BER) base, bipolar violation (BPV)
- data links
- local loops
- alarm detection: local (red), remote (yellow)

The AB version supports the following functions:

- extended super frame format (ESF)
- B8ZS
- BER, CRC
- data links for SLC-96 and facility data link (FDL) to enable the carrier facility
- remote loops
- AIS detection



The following combinations are *invalid* for the NT6X50AB card:

- SF with BER based on CRC
- SF with FDL
- ESF with SLC-96

### **DS-1 link error reporting**

The PM tracks the following errors with respect to the DS-1 link:

- BER
- CRC violations
- BPV for either frame format
- out of frame (OOF) and slips
- errored seconds (ES)
- severely errored seconds (SES)
- unavailable seconds (UAS)

BER calculations based on CRC errors detect problems on the T1 span, whereas BPV errors are relevant to only the last line in the span. Therefore, CRC-based BER is preferable over BPV-based BER for day-to-day monitoring. The BPV BER is available for investigating problems with the last DS-1 line in the path. Only BPV-based BER is available with fixed maintenance and out-of-service thresholds.

For ES, 16 coding violations are treated as one unit of measurement.

The SES counts the quantity of seconds during which coding violations are experienced with an approximate BER of  $10^{-3}$ . The measurement occurs only during UAS.

After ten consecutive SES, the system makes the service SysB. All subsequent seconds are UAS, but after ten consecutive non-SES, the system makes service unavailable.

### **DS-1 fault indications**

A fault in the transmit direction of the DS-1 interface can produce the following errors:

- no data is transmitted over the DS-1 link
- only one side of the line is active, resulting in a continuous bipolar violation state at the far end
- the outgoing signals are poor, resulting in a high error rate and poor synchronization at the far end

A fault in the receive direction can produce the following errors:

- loss of synchronization due to a poor or a non-existent signal
- high error rate for a receive signal
- high bipolar violation rate
- no receive clock being generated, so that the incoming serial bit stream cannot be sampled

Receive faults show up as

- a synchronization problem
- a high bipolar violation rate
- a high CRC rate in the EFF

### DS-1 alarm thresholds

Some thresholds signify a maintenance level and the others signify the out-of-service level.

The carrier group alarms—local, remote, and (AIS—also have user-defined alarm points associated with each digroup. These alarm points signify the filter period in use to time the alarm. Two filter periods are required: one to define the entry into the alarm, and one to define the exit from the alarm.

Table 12-4 summarizes the default settings for the alarm points.

**Table 12-4 DS-1 alarm thresholds (Sheet 1 of 2)**

Alarm	Threshold
Local carrier group alarm (red)	Entry: 2.5 s, exit: 10 s
Remote carrier group alarm (yellow)	Entry: 0.5 s, exit: 0.5 s
AIS carrier group alarm entry	1.5 s, exit: 10 s
BIT error rate (BER)	Maintenance level: $10^{-6}$ Out-of-service level: $10^{-3}$
Out Of Frame (OOF)	Maintenance level: 17 in 24 h, Out-of-service level: 511 in 24 h
Slips	Maintenance level: 4 slips in 24 h, Out-of-service level: 256 in 24 h

**Table 12-4 DS-1 alarm thresholds (Sheet 2 of 2)**

Alarm	Threshold
ES	864s
SES	100s

## PM troubleshooting notes

This section contains some notes that can help while troubleshooting PM-related PRI problems.

### Auditing data mismatches

The DMS-core continually audits static data and PM programs by using checksums. If the audit passes, then a return to service (RTS) does not reload the PM software and tables. If the audit fails, a SWACT occurs, the affected PM is system busied, returned to service, and reloaded with software.

### Activity monitoring with PMACT and ISP commands

PMACT and ISP commands of the PM;PERFORM level are in use to analyze the real-time usage of the signaling processor (SP), the master processor (MP), and the ISP. Measurements are made in the following categories:

- call processing occupancy
- high-priority background occupancy
- low-priority background occupancy

The combination of the call processing occupancy and the high-priority background occupancy represent time in use in providing service.

Low-priority background occupancy represents time in use for audits and testing. The display data updates once each minute and includes an average occupancy for the last 15 min.

At the PMACT level, primarily in use for PM performance monitoring, other display data includes the peak and the average use of universal tone receivers (UTRs) and of P-side channels. Originations and terminations are also counted. Terminations are defined as calls that cause ringing (or flashing). The counts include the quantity of channels that are available to call processing.

The ISP level primarily is in use to monitor ISP and D-channel performance. Data is collected on ISP real-time occupancy and the display data includes the number and type of service access point identifier (SAPI), frames transmitted and received successfully, and the total number of SAPI frame errors transmitted and received.

Both PMACT and ISP tools can be used simultaneously on the same node. All data measurements are accumulated for up to 1 h, and only on the active unit. The accumulated data is not maintained for a warm or cold SWACT. Only one user at a time can monitor the performance data for a PM, but up to five PMs can be included in the data accumulation.

**Logging PERFORM data**

All of the data collected by the PERFORM command may be recorded in logs PRFM200, PRFM201, PRFM204, and PRFM210, including the names of the XPM loads. By default, logs are generated every 15 min under any of the following conditions:

- A SWACT occurs.
- The active unit drops activity and is not backed up by the inactive unit.
- The command STOP is used at the PMACT or the ISP level.
- The timer for producing logs expires.

**Datafill issues**

Errors in the datafill of PRI-related tables will produce operational problems. To help track down such datafill-related problems, Table 12-5 lists various PRI capabilities and features against the data tables that contain information related to the capability. Notice that some tables contain information related to more than one capability.

For more information about PRI datafill, refer to the *Translation Guide*.

**Table 12-5 Table categories (Sheet 1 of 2)**

Capability	Tables
Base service	ADJNODE, CARRMTC, CLLI, LTCINV, LTCPSINV,LTDEF, LTGRP, LTMAP, PADDATA, TRKGRP, TRKMEM, TRKSGRP
Bearer capability routing	BCDEF, HNPACONT.RTEMAP, HNPACONT.RTEREF, IBNMAP, IBNRTE, IBNXLA, LTCALLS, OFRT, OFRTMAP, PXLAMAP, RCNAME, RTECHAR, TRKGRP, XLAMAP
Network Name Delivery	CUSTNTWK, NETNAMES
Network Ring Again	CUSTNTWK, MSGRTE, NETNAMES
Backup D-channel	TRKSGRP
PRI call routing	ISAXLA, LTCALLS, LTDATA
Message Waiting	MSGRTE, NETNAMES

**Table 12-5 Table categories (Sheet 2 of 2)**

Capability	Tables
Display information element blocking	TRKSGRP, ISDNPARM
Flexible timers	ISDNPROT
CLI blocking	LTCALLS, LTDATA
Equal access	LTCALLS
ISDN call treatments	LTDATA
PRI trunk groups	CLII, PADDATA, TRKGRP, CARRMTC
Logical terminal (the adjacent node)	LTGRP, LTDEF, LTMAP, ADJNODE
Switching node connection	PRIPROF

### Integrated service access (ISA) troubleshooting

PRI call failures may be due to problems associated with ISA. ISA is the part of PRI call routing that allows different types of calls to be routed over the same PRI trunk group. Table 12-6 describes the call types ISA supports.

**Table 12-6 ISA Types (Sheet 1 of 2)**

ISA Type	Description
Public (PUB)	These calls connect the end user to the public switched telephone network (PSTN). With direct inward dialing (DID), public calls connect the DMS-100 to a PBX. With direct outward dialing DOD, public calls connect the PBX with the DMS-100. Dialed digits must conform to E.164.
Private (PVT)	These calls connect the PBX to its virtual private network (VPN). The DMS-100 uses the PSTN to support a private numbering plan. The dialed digits may not conform to E.164.
OUTWATS (WATS)	These calls to PSTN destinations are charged in blocks of time for flat monthly rates according to geographical zones or bands.
INWATS	800 numbers that are charged to the called party customer.

**Table 12-6 ISA Types (Sheet 2 of 2)**

ISA Type	Description
Foreign exchange (FX)	A trunk connecting the usual end office of a PBX to some other remote office. This provides the equivalent of local service in the remote location for the PBX for incoming and outgoing PSTN calls.
Tie line (TIE)	Tie lines are trunks that directly connect two PBXs.

The Q.931 setup message contains two critical information elements, numbering plan indicator (NPI) and network specific facilities (NSF). Errors in either of these elements cause the intended call to fail. The NPI element is contained in the called party number (CDN) information element of the setup message, and indicates whether the numbering plan is public or private. The NSF indicates which network facilities to use for the call.

The NSF contains

- a service selector that specifies the type of service requested
- an optional service identifier (SID) to specify the actual facility to be used to route the call. INWATS calls can be routed on the SID for all call types except public.

For a PRI-to-non-PRI call, the NSF is in use by LTCALLS to determine the translations, and then ignored because it is not used by the terminator.

For a PRI-to-PRI call, the NSF is used by both originator and terminator. Since the information is specific to the particular PRI, the NSF can be different on each PRI of the call

For a non-PRI-to-PRI call, there is no NSF in the origination and so the NSF information is obtained from the routing tables. If ISA is not used as the routing selector, then no NSF is generated for the terminator.

For more information about how the DMS-100 switch routes ISA PRI calls, refer to the *Translations Guide*.

## Troubleshooting PRI call processing

This section presents detailed information about PRI call processing, including descriptions of call states and the steps in call processing. The terminology viewpoint in this section is from the subscribers side (the adjacent node) of the PRI.

**Circuit-switched call states**

Table 12-7 lists the states that a call can be in during its existence. The call direction terms, incoming and outgoing, are viewed from the subscriber's side of the interface. Notice these states are for an individual call and not for the interface, since the interface can have several calls occurring simultaneously.

**Table 12-7 PRI call states (Sheet 1 of 2)**

<b>User state</b>	<b>Network state</b>	<b>State name</b>	<b>Call direction</b>	<b>Description</b>
U0	N0	Null	no call exists	
U1	N1	Call Initiated	outgoing	User has requested call establishment from the network and is awaiting a response.
U3	N3	Outgoing Call Proceeding	outgoing	User has received acknowledgment that the network has received information necessary to establish a call.
U4	N4	Call Delivered	outgoing	User has received an indication that remote user alerting has been initiated.
U6	N6	Call Present	incoming	User has received call establishment request but has not yet responded.
U7	N7	Call Received	incoming	User has initiated local alerting but not yet answered.
U8	N8	Connect Request	incoming	User has answered and is waiting to be awarded the call.
U9	N9	Incoming Call Proceeding	incoming	User has acknowledged receiving all information necessary to establish a call.
U10	N10	Active	incoming	User has received notification from the network that the user has been awarded the call.
U10	N10	Active	outing	User has received information that the remote user has answered.
U11	N11	Disconnect Request	either	User has requested the network to clear the end-to-end connection and is awaiting a response.

Table 12-7 PRI call states (Sheet 2 of 2)

User state	Network state	State name	Call direction	Description
U12	N12	Disconnect Request	none	Network has received a request to disconnect because the user has disconnected the end-to-end connection.
U19	N19	Release Request	none	User has requested for the network to release the user-network connection, and is awaiting a response.

### Global states

Table 12-8 shows the possible states of the PRI interface, as opposed to the states of calls on the interface.

Table 12-8 PRI global states

User state	Network state	State name	Call direction	Description
R0	R0	Null		No transaction exists.
R1	R1	Restart request	outgoing	User or network has requested a restart and is awaiting a response.
R2	R2	Restart	outgoing	User or network has received a request from the network or user for a restart and responses have not been received from all locally active call references.

**Note:** There is only one global call reference for each interface.

### Call establishment at the originating interface

Before call procedures are invoked, a reliable data link connection must be established between the user and the network using the DL-DATA-REQUEST primitive from the network layer to the data link layer.

#### Call request

The call is initiated by the SETUP message, which contains a call reference, bearer capability, channel ID, and called party number. Sending the SETUP message places the call in the call-initiated state. The user can indicate that a specific channel is required with no alternative allowed, or that a specific channel is requested and any alternative is acceptable.

If a channel is available, the network returns the B-channel identifier in the response, and activates the B-channel connection. The network assumes that the B-channel is attached after the network has delivered call proceeding



(CALL PROC), progress (PROG), or alerting (ALERT) messages to the user with progress indicator 8—the in-band information or the appropriate pattern is now available. Before this occurs the network does not assume the B-channel is connected.

If the requested channel is not available, the network responds with release complete (REL COM) with cause 44—the requested channel is not available, or if the maintenance state of the link is manual busy, the network responds with cause 82—the identified channel does not exist.

If any of the information elements in the SETUP message are invalid, the call will be cleared with one of the following causes:

- cause 1—unallocated number
- cause 3—no route to destination
- cause 22—number changed
- cause 28—invalid number format

### **Call proceeding**

If the SETUP message is valid, and the network is attempting to complete the call, the network will respond with CALL PROC and both user and network go into the Outgoing Call Proceeding state.

If the requested service is not available or not authorized then the call is cleared with one of the following causes:

- cause 34—no circuit/channel available
- cause 57—bearer capability not authorized
- cause 58—bearer capability not presently available
- cause 63—service/option not available, unspecified
- cause 65—bearer capability not implemented

If the call is not end-to-end ISDN, the progress indicator 1—call not end-to-end-ISDN and more information can be available in-band, is returned to the user. The caller should stop supervisory timers and connect to and monitor the B-channel.

### **Alerting**

The network sends ALERT message when it receives confirmation that user alerting is initiated at the called address. At this time, both the user and the network enter the Call Delivered state. If the bearer capability is speech or 3.1-kHz audio, then the network sends progress indicator 8—in-band information or appropriate pattern is now available.

**Call connected**

When the network receives confirmation that the call is accepted (answered) it sends a connect (CONN) message to the user, and both the user and the network enter the Active state. This means the call is connected end-to-end.

**Call rejection**

When the network receives an indication that either the terminating network or the called user is unable to accept the call, the network initiates clearing at the user-network interface. The network uses the cause provided by the terminating network or the called user.

**Call establishment at the destination interface**

An incoming call is indicated by arrival of a SETUP message from the network. After sending the SETUP message, the network starts timer T303 and both the user and the network enter the Call Present state. If the user does not respond before T303 expires, the message is resent and T303 is restarted.

The user is responsible for determining bearer compatibility after receiving the SETUP message. If the offered compatibility is not acceptable, then the user responds with REL COM with cause 88—incompatible destination. Both the user and the network enter the Null state.

The network also specifies a particular B-channel in the SETUP message. There are no acceptable alternatives. If the B-channel indicated in the users first response is not the channel offered by the network, the network clears the call by sending a REL message with cause 6—channel unacceptable. When the users accepts the B-channel, then the user can connect to that channel.

If the indicated B-channel is not available, the user returns REL COM with cause 44—requested channel not available, or if the maintenance state is manual busy, the user responds with cause 82—identified channel does not exist.

**Call confirmation**

Table 12-9 shows valid responses to the SETUP message.

**Table 12-9 Valid SETUP message response**

Called user action	User send this message	User's cause	User's next state	User notes	Network notes
Accept immediately	CALL PROC		Incoming Call Proceeding		stop T303 start T310 enter state Incoming Call Proceeding
	ALERT		Call Received	start T301	stop T303 or T310 enter Call Received relay ALERT message to calling user
	CONN		Connect Request		
Delay	CALL PROC		Incoming Call Proceeding	stop T303	
Busy	REL COM	cause 17 user busy			stop T303 or T310 clear back to caller
Incompatible	REL COM	cause 88— incompatible destination			
Refuse	REL COM	cause 21— call rejected	Null		

**Call failure**

If the user does not respond to the SETUP message before timer T303 expires, the network starts clearing procedures toward the calling user with cause 18—no user responding, and toward the called user with cause 102—recovery on timer expiry.

If the network receives a CALL PROC message, but does not receive an ALERT, CONN, or DISC message prior to expiration of T310, then the network initiates clearing toward the calling user with cause 18—no user

responding, and towards the called user with cause 102—recovery on timer expiry.

If the called user is providing ringback and its timer T301 equivalent expires before the call connects or clears, then the called user initiates clearing toward the network with cause 19—no answer from user (user alerted).

### **Notification of interworking**

The called user has the responsibility to notify the calling user if the call leaves the ISDN environment. The called user sends a PROG message with value 1—call is not end-to-end ISDN, to the calling user. More call progress information can be available in-band.

### **Call accept**

A called user accepts an incoming call by sending a CONN message to the network and starting timer T313. If the called user accepts a call using the B-channel indicated in the SETUP message, and does not require a user alerted message, a CONN message can be sent. If the CONN message is the first response to the SETUP, it must contain the channel.

### **Active indication**

When the network receives the CONN message, the network causes the following events:

- sends a connect acknowledge (CONN ACK) to the user
- completes the B-channel path
- dispatches a CONN message to the calling user
- enters the Active state

If the T313 expires before the call connects, the called user starts clearing with cause 1021—recovery on time expiration.

### **Call clearing**

The following definitions are used in call clearing:

- **Connected**—A channel connects when the channel is part of an established circuit-switched ISDN connection.
- **Disconnected**—A channel disconnects when it is no longer part of the circuit-switched ISDN connection it is not yet available for a new connection.
- **Released**—A channel releases when the channel is available for a new connection.

Normal clearing is initiated by either the user or the network sending a DISC message. Call clearing also occurs with one of the following actions:

- the user or network rejects a call by sending a REL COM message
- the B-channel selection procedure unsuccessfully terminates and the network sends a REL message along with cause 6

### **Clearing by the user**

***Initiate clearing by completing the following steps:***

- 1 Send the DISC message.
- 2 Start the timer T305.
- 3 Disconnects the B-channel. The network responds by disconnecting the B-channel. After disconnecting the B-channel, the network sends a REL message back to user, starts T308, and enters the Release Request state.
- 4 Enter the Disconnect Request state. The network enters the disconnect request state. The network initiates procedures for clearing the network connection back to the remote user.

***When you receive the REL message from the network, perform the following steps.***

- 1 Cancel Timer T305.
- 2 Release the B-channel.
- 3 Send the REL COM message.
- 4 Release the call reference.
- 5 Enter the null state.

***If the network does not receive the REL COM message before timer T308 expires for the second time (the first time the network retransmits the REL message), the network performs the following steps:***

- 1 Place the B-channel in a maintenance condition.
- 2 Release the call conference.
- 3 Return to the null state.

***If the timer T305 expires, performs the following steps:***

- 1 Sends a REL message with cause that was in the DISC message.
- 2 Starts timer T308.
- 3 Enters the release request state.

***When the timer T308 expires for the first time, perform the following steps:***

- 1 Retransmit the REL message.
- 2 Restarts the T308.

***When the T308 expires a second time, performs the following steps:***

- 1 Place the B-channel in a maintenance condition.

- 2 Release the call reference:
- 3 Return to the null state.

### **Clearing by the network**

There are two cases in which the network clears a call: (1) when tones are provided, and (2) when tones are not provided.

***When tones or announcements are provided in conjunction with call clearing, the network performs the following step:***

- 1 Send a PROG message.

***When tones or announcements are not provided, the network performs the following steps:***

- 1 Send a DISC message.
- 2 Start T308.
- 3 Enters a release request state.

When the user receives the DISC message, the network

1. disconnects the B-channel
2. sends a REL message
3. starts T308
4. enters Release Request state

When the network receives the REL message, the network

1. stops T305
2. releases the B-channel
3. sends REL COM message
4. releases the call reference
5. enters the Null state

If T305 expires, the network

1. sends REL message with the cause that was in the DISC message
2. starts T308
3. enters Release Request state

### **Completion of clearing**

When the network receives the REL COM message, the network

1. stops T308
2. releases the B-channel

3. releases the call reference
4. enters the Null state

If the network does not receive the REL COM message, or the user before the second expiration of T308 (the first expiration causes retransmission of the message) the network or user

1. places the B-channel in a maintenance condition
2. releases the call reference
3. enters the Null state

### **Clear collisions**

A clear collision occurs when both the user and the network try to clear the same call reference, or if both the user and the network receive a DISC message while in the Disconnect Indication state. Both ends must perform the following sequence:

1. stop T305
2. send a REL message
3. start T308
4. enter Release Request state

In addition to the above steps, the user should disconnect the B-channel if it is not already disconnected.

### **Interworking with existing networks**

It is always the responsibility of the interworking exchange (the interworking exchange is the exchange that must connect together the ISDN and non-ISDN circuits) to provide the PROG message with value 1—call is not end-to-end ISDN, and to monitor the non-ISDN circuit for answer and disconnect supervision.

### **Audible ringback**

The terminating exchange (ISDN or non-ISDN) always generates ringback and maintains a T301 equivalent. ISDN exchanges also provide PROG and ALERT messages as required by the protocols. The terminating exchange performs the following functions:

- determines if the end-point terminal is available
- alerts the end-user terminal, transmits the altering indicator back to the originating exchange with in-band ringback, and starts T301 equivalent
- sends CONN or other off-hook message, stops ringback, and stops the timer T301 when the terminal answers.

**Busy tones**

For an ISDN-to-ISDN network connection, the B-channel disconnects using the REL protocol and the busy tone generates locally. For a non-ISDN-to-ISDN network connection, the interworking exchange generates the busy signal. For an ISDN-to-non-ISDN network connection, the tone generates by the terminating exchange. Notice that a PROG message is sent with a progress indicator 1 from the user to the network to indicate that the call is not an end-to-end ISDN call and call process information is only available in-band.

**Announcements**

Calls within an ISDN can have treatments applied with in-band tones and voice announcements.

**Restart procedure**

Use the restart procedure to return channels and interfaces to an idle condition (the Null state). The procedure starts when one of the following conditions occur:

- when a data link is established
- following T308 expiration for the second time

To begin the restart procedure, the network performs the following steps:

1. sends the restart (REST) message
2. starts T316
3. waits for restart acknowledge (REST ACK) message

When the REST ACK is received, the receiver performs the following steps:

1. stops T316
2. frees the channels and call reference values for reuse
3. enters the Null state

If the T316 expires, the procedure is repeated. If the procedure is still unsuccessful, notify the maintenance entity. Restart attempts may continue, but the channel or interface is considered out-of-service. The receiver of the REST message performs the following steps:

1. enters the Restart state
2. starts T317
3. returns all channels to idle and call references to null
4. stops T317
5. sends REST ACK message



## Digital test access

Digital test access (DTA) is an optional feature package, NTXS12AA. DTA is a digital monitoring method for PRI D-channels. DTA provides a refined method of accessing D-channel information. Instead of using a metallic path between the DS-1 and the test equipment, DTA establishes access by replicating the digital data streams on the channel.

DTA monitors the following data on an ISDN PRI circuit:

- D-channel
- backup D-channel

DTA monitors two streams of digital data: the data that flows toward the subscriber (downstream data) and the data that flows away from the subscriber (upstream data). DTA establishes monitoring capability by replicating the digital streams of data to and from the monitored point without affecting the streams being monitored.

DTA performs monitoring with a commercially available protocol analyzer. The monitoring point for the upstream data of the D-channels is the timeswitch of the XPM. The downstream data is derived from the EISP in the XPM (refer to Figure 12-3). Each of these streams is made available to the protocol analyzer through

- two channels of a DS-1 interface supported by DTCL, LTC, DTC, or LGC provisioned for 64-kbit/s clear data transmission
- the B1 and B2 channels of an ISDN line card, if available

The DTA feature requires two XPM C-side channels to be available for the upstream or downstream connection to the protocol monitoring location. DS-1 trunks have fixed C-side channel allocations; therefore, there must be at least two unassigned channels to make a DTA connection on the DTCL.

The PRADCH level of the MAP display is in use for all user interfaces with this feature. The DTA connection is established and operating company personnel can remove the connection from the MAP display.

The protocol analyzer required for DTA must be capable of connecting to the DS-1 digital interface or an ISDN S/T-loop interface, depending on the monitoring point. The protocol analyzer must also decode Q.921, Q.931, and X.25 protocols.

Figure 12-3 DTA access points - monitoring PRI D channel

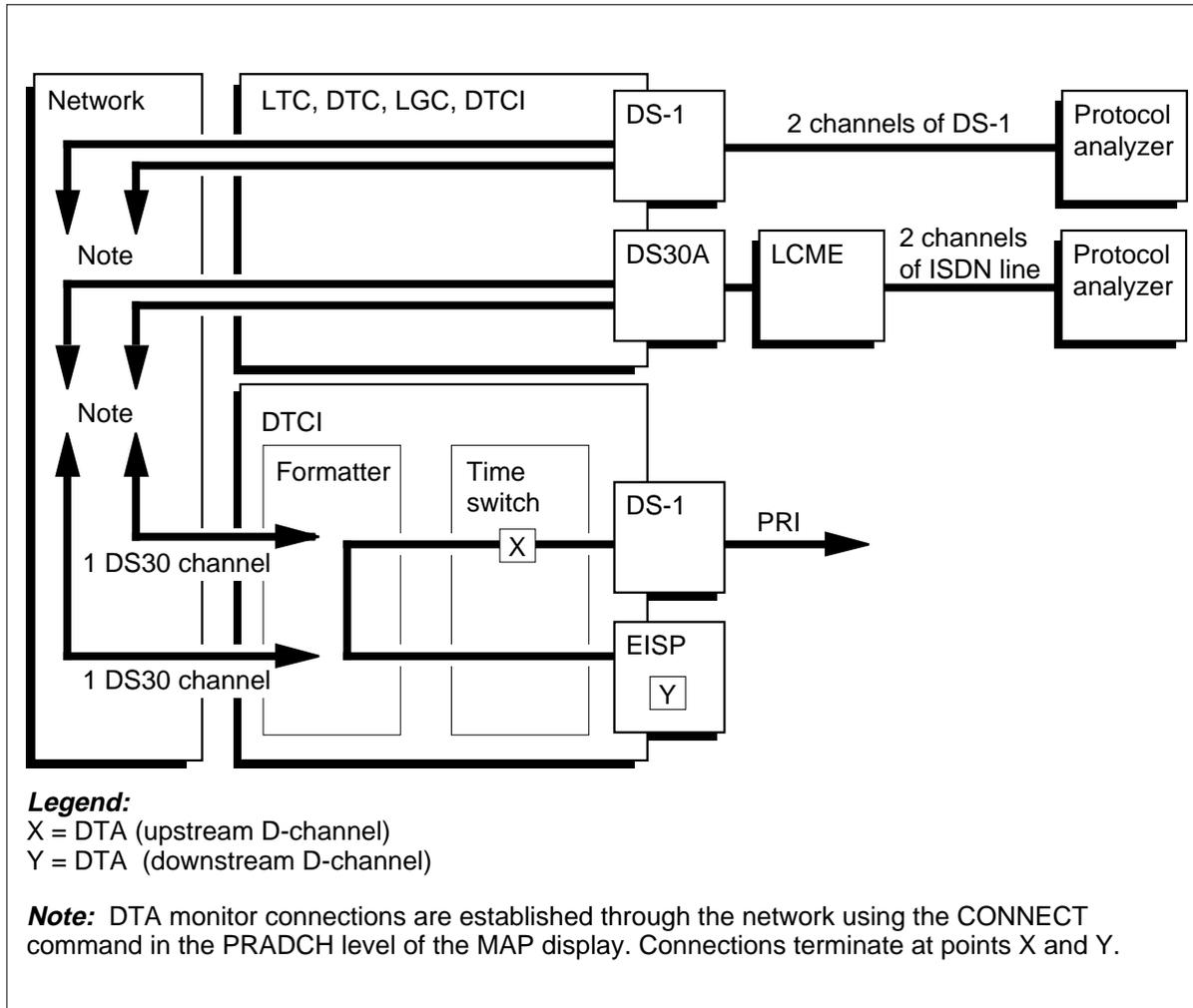

### DTA commands

Table 12-10 describes the MAP commands that enable DTA.

Table 12-10 DTA commands

Command	Description
<b>PRADCH level</b>	
CONNECT	Allows DTA to be performed on the PRI D channel being monitored.
EQUIP	Reserves DS-1 equipment or an ISDN line card (if available) for use in DTA monitoring. It also allows the reserved equipment to be queried and released.



## 13 Troubleshooting chart

This chapter contains a troubleshooting chart to help you find the possible causes and recommended actions for service-affecting troubles. This chart contains the following information:

- a description of the problem in the first column
- the meaning in the second column
- the recommended actions in the third column

**Table 13-1 ISDN troubleshooting (Sheet 1 of 5)**

<b>Problem</b>	<b>Meaning</b>	<b>Action</b>
B channel does not come into service		Refer to the section "Troubleshooting B- and D-channels" in the chapter "Advanced troubleshooting procedures."
Calls do not complete		Refer to the section "Troubleshooting calls that will not complete" in the chapter "Advanced troubleshooting procedures."
D-channel state is CFL	The carrier failed.	Isolate the fault as described in <i>Alarm and Performance Monitoring Procedures</i> .
D channel state is INB	The D-channel is installation busy	Return the D-channel to service as described in <i>Trouble Locating and Clearing Procedures</i> .
D-channel state is INI	The D-channel is being initialized	No action is required. The system brings up the D-channel.

Table 13-1 ISDN troubleshooting (Sheet 2 of 5)

Problem	Meaning	Action
D-channel state is LO	Locked out—the logical link failed.	<p>Enter table TRKSGRP.</p> <ul style="list-style-type: none"> <li>Verify that the baud rate datafill matches that of the far-end DS-1.</li> <li>Verify that the entry for field IFCLASS is NETWORK.</li> </ul> <p>At the DTCL, verify that the correct DS-1 (NT6X50AB) card is in use.</p> <p>Verify that layer 1 attributes, such as frame format (standard or extended), match at both ends of the link.</p> <p>For more information, refer to <i>Trouble Locating and Clearing Procedures</i>.</p>
D-channel state is MB	The D-channel is manual busy.	Return the D-channel to service as described in <i>Trouble Locating and Clearing Procedures</i> .
D channel state is PMB	The DTCL is manual busy.	Isolate the fault as described in <i>Alarm and Performance Procedures</i> .
D-channel state is RNR	The remote far end layer 3 is not responding.	For more information, refer to <i>Trouble Locating and Clearing Procedures</i> .
D-channel state is STB	Backup D-channel is in the standby mode	No action is required. The backup D-channel is available if a switchover occurs or is requested.
D-channel state is WAI	Backup D-channel is in the wait mode prior to switchover.	No action is required. The backup D-channel activates and is placed in the INS state.
D-channel does not come into service		Refer to the section “Troubleshooting B- and D-channels” in the chapter “Advanced troubleshooting procedures.”
Datafill problems		Refer to the section “Datafill issues” in the chapter “Trouble isolation and correction methods.”

**Table 13-1 ISDN troubleshooting (Sheet 3 of 5)**

<b>Problem</b>	<b>Meaning</b>	<b>Action</b>
DTCI is CBSY	The DTCI is C-side busy,	From the PM level of the MAP: <ul style="list-style-type: none"> <li>• Post the DTCI.</li> <li>• Enter TRNSL C.</li> <li>• Diagnose the C-side links that are not in service.</li> </ul>
DTCI is ISTB	The DTCI is in-service trouble.	From the PM level of the MAP: <ul style="list-style-type: none"> <li>• Post the DTCI.</li> <li>• Enter QUERYPM FLT.</li> <li>• Diagnose the fault.</li> </ul>
DTCI is MANB	The DTCI is manual busy.	From the PM level of the MAP: <ul style="list-style-type: none"> <li>• Post the DTCI.</li> <li>• RTS the DTCI.</li> </ul>
DTCI is SYSB	The DTCI is system busy due to a problem the system detected.	A system log generates for the fault that occurred.  Diagnose the problem.  The system returns the DTCI to service if it finds no fault.
DS-1 carrier is CBSY	The carrier is C-side busy.	From the CARRIER level of the MAP, diagnose the C-side links that are not in service.
DS-1 carrier is OFFL	The carrier is off-line.	From the CARRIER level of the MAP, BSY and RTS the carrier.
DS-1 carrier is MB	The carrier is manual busy.	From the CARRIER level of the MAP, RTS the carrier.  Note the new carrier state.
DS-1 carrier is SYSB	The carrier is system busy.	From the CARRIER level of the MAP, diagnose the fault.  Note the new carrier state.
DS-1 carrier problems		Refer to the section "DS-1 maintenance signaling notes" in the chapter "Trouble isolation and correction methods."

Table 13-1 ISDN troubleshooting (Sheet 4 of 5)

Problem	Meaning	Action
Hardware problems		Refer to the section "Hardware model" in the chapter "Trouble isolation and correction methods."
Initial installation troubles	A datafill or T-1 span problem	Refer to the section "Initial installation troubles" in the chapter "Trouble isolation and correction methods."
In-service troubles		Refer to the section "In-service troubles" in the chapter "Trouble isolation and correction methods."
PM troubles		Refer to the section "PM troubleshooting notes" in the chapter "Trouble isolation and correction methods."
PRI call processing troubles		Refer to the section "Troubleshooting PRI call processing" in the chapter "Trouble isolation and correction methods."
Software problems		Refer to the section "Software model" in the chapter "Trouble isolation and correction methods."
Trunk state is CFL	The carrier is out of service	Isolate the fault as described in <i>Alarm and Performance Monitoring Procedures</i> .
Trunk state is DFL	D-channel failed	Isolate the fault as described in <i>Trouble Locating and Clearing Procedures</i> .
Trunk state is DMB	D-channel is manual busy.	Isolate the fault as described in <i>Trouble Locating and Clearing Procedures</i> .
Trunk state is INB	The trunk is installation busy.	Return the trunk to service as described in <i>Trouble Locating and Clearing Procedures</i> .
Trunk state is LO	The D-channel is locked out and cannot communicate with layer 3.	Isolate the fault as described in <i>Trouble Locating and Clearing Procedures</i> .

**Table 13-1 ISDN troubleshooting (Sheet 5 of 5)**

<b>Problem</b>	<b>Meaning</b>	<b>Action</b>
Trunk state is MB	The trunk is manual busy.	Return the trunk to service as described in <i>Trouble Locating and Clearing Procedures</i> .
Trunk state is PMB	The DTCL is manual busy.	Isolate the fault as described in the <i>Alarm and Performance Procedures</i> .
Trunk state is SB	The PRI circuit is system busy	The system returns the trunk to service after testing is complete.





# 14 Cause values

## Mapping cause values to treatments

The cause information element describes the reason for generating certain messages, provides diagnostic information in the event of procedural errors, and indicates the location of the cause originator.

Table 14-1 contains cause values that are mapped to DMS-100 in-band treatments. The bracketed number beside the treatment indicates the type of extended treatments defined in the DMS-100. (Cause values not in table 14-1 are reserved).

**Table 14-1 Mapping cause values to treatments (Sheet 1 of 4)**

Cause value and name	Treatment
<b>Normal event class</b>	
1. unallocated (unassigned) number	BLDN (6)
2. no route to specified transit network	CACE (79)
3. no route to destination	RODR (25)
6. channel unacceptable	CHNF (160)
7. call awarded and being delivered in an established channel	RODR (25)
16. normal call clearing	none
17. user busy	BUSY (19)
18. no user responding	NTRS (133)
19. no answer from user (user alerted)	RODR (25)
21. call rejected	CREJ (134)
<b>Note:</b> * Reroute generally means that a protocol error has occurred on the selected channel. Another trunk termination is attempted. If the attempt is unsuccessful, then treatment GNCT (34) is applied.	

Table 14-1 Mapping cause values to treatments (Sheet 2 of 4)

Cause value and name	Treatment
22. number changed	CNAC (113)
26. non-selected user clearing	RODR (25)
27. destination out of order	RODR (25)
28. invalid number format (incomplete number)	PDIL (2)
29. facility rejected	NACK (78)
30. response to STATUS ENQUIRY	none
31. normal, unspecified	RODR (25)
<b>Resource unavailable class</b>	
34. no circuit/channel available	NCRT (24)
38. network out of order	SYFL (14)
41. temporary failure	CHNF (160)
42. switching equipment congestion	NBLH (9)
43. access information discarded	reroute to next B-channel*
44. requested circuit/channel not available	Reroute to next B-channel*
47. resources unavailable, unspecified	NOSR (93)
<b>Service not available class</b>	
50. requested facility not subscribed	FNAL (68)
54. incoming calls barred	DTNR (33)
57. bearer capability not authorized	CNAC (113)
58. bearer capability not presently available	CNAC (113)
63. service or option not available, unspecified	NACK (78)
<b>Note:</b> * Reroute generally means that a protocol error has occurred on the selected channel. Another trunk termination is attempted. If the attempt is unsuccessful, then treatment GNCT (34) is applied.	

**Table 14-1 Mapping cause values to treatments (Sheet 3 of 4)**

<b>Cause value and name</b>	<b>Treatment</b>
<b>Service not implemented class</b>	
65. bearer capability not implemented	BCNI (161)
66. channel type not implemented	CONP (98)
69. requested facility not implemented	RODR (25)
70. only restricted digital information bearer capability is available	CNAC (113)
79. service or option not implemented, unspecified	FNAL (68)
<b>Invalid message class</b>	
81. invalid call reference value	CHNF
82. identified channel does not exist	CHNF
83. a suspended call exists, but the call identity does not	RODR (25)
84. call identity in use	RODR (25)
85. no call suspended	RODR (25)
86. call having the requested call identity has been cleared	RODR (25)
88. incompatible destination	CNAC (113)
95. invalid message, unspecified	RODR (25)
<b>Protocol error class (message not recognized)</b>	
96. mandatory information element is missing	CHNF
97. message type non-existent or not implemented	CHNF
98. message not compatible with call state, or message type non-existent or not implemented	CHNF
99. information element non-existent or not implemented	CHNF
100. invalid information element contents	CHNF
101. message not compatible with call state	CHNF
<b>Note:</b> * Reroute generally means that a protocol error has occurred on the selected channel. Another trunk termination is attempted. If the attempt is unsuccessful, then treatment GNCT (34) is applied.	

**Table 14-1 Mapping cause values to treatments (Sheet 4 of 4)**

Cause value and name	Treatment
102. recovery on timer expiry	CHNF
111. protocol error, unspecified	CHNF
<b>Interworking class</b>	
127. interworking, unspecified	none
<b>Note:</b> * Reroute generally means that a protocol error has occurred on the selected channel. Another trunk termination is attempted. If the attempt is unsuccessful, then treatment GNCT (34) is applied.	

## Mapping treatments to cause values

When the DMS-100 routes a call to treatment, a message with a cause value is sent to the user indicating why the call went to treatment.

More than one treatment may generate a specific cause value. In addition, only a small number of the existing treatments map to meaningful cause values. All remaining treatments map to the cause value of 127, and the treatment is applied in-band.

Table 14-2 contains the treatments and the corresponding cause values to which they map. For definitions of the treatments, refer to the data schema section of the *Translations Guide*.

**Table 14-2 Mapping treatments to cause values (Sheet 1 of 2)**

Treatment	Cause value
ATBS (attendant busy)	31
BCNI (bearer capability not implemented)	65
BLDN (blank directory number)	1
BUSY (busy line)	17
CACE (carrier access code error)	2
CHNF (channel negotiation failure)	41
CNAC (call not accepted)	88
CONF (confirm tone)	31
CONP (connection not possible)	66

**Table 14-2 Mapping treatments to cause values (Sheet 2 of 2)**

<b>Treatment</b>	<b>Cause value</b>
CREJ (call rejected)	21
DNTR (denied termination)	54
FNAL (feature not allowed)	50
GNCT (generalized no circuit)	34
MHLD (music on hold)	31
NACK (feature action not acknowledged)	29
NBLH (network blockage heavy traffic)	42
NBLN (network blockage normal traffic)	34
NCRT (no circuit)	34
NOSC (no service circuit)	34
NOSR (no software resource)	47
NTRS (no terminal responding)	18
PDIL (parital dial)	28
PSIG (permanent signal)	90
RODR (reorder)	28
SYFL (system fail)	41
TRBL (trouble intercept)	27
UNDN (unassigned directory number)	1
VACT (vacant code)	1



---

# 15 Troubleshooting example

---

This chapter shows a sample troubleshooting session for a PRI call that fails. This example shows an abbreviated version of the steps listed in the troubleshooting procedure "Troubleshooting when calls will not complete" in the chapter "Advanced troubleshooting procedures" in this NTP as well as the actual TRAVER and PMDEBUG data.

The call is an incoming 7-digit call is whose call type is unknown.

## Troubleshooting calls that will not complete

The following procedure is for call that don not complete.

### Procedure 15-1 Troubleshooting calls that will not complete

#### *At your current location*

- 1 Review maintenance actions taken to date.
- 2 Verify that the DMS switch is loaded with the correct feature packages
- 3 Verify that the far-end equipment has the necessary software to support the service being provided
- 4 Verify the datafill in table TRKSGRP, field SGRPVAR, subfield CRLNGTH (call reference length). The CRLNGTH must match the far-end.

After the first four steps the call still fails. In this example, the call type is incorrectly assumed to be a public call. The following TRAVER is issued and indicates that the call should complete, but the call still fails.



**Figure 15-1 Example >traver tr pratest2 6753002 b**

```

>traver tr pratest2 6753002 b
TABLE TRKGRP
PRATEST2 PRA 0 NPDGP NCRT ASEQ N (ISDN 1001) $
TABLE LTCALLS
ISDN 1001 PUB XLAIBN 0 BNR 00 $
TABLE LINEATTR
0 1FR NONE NT NSCR 0 619 P351 NLCA RTE4 0 NIL NILSFC
NILLATA 0 NIL NIL 00 Y POTS
LCABILL OFF - BILLING DONE ON BASIS OF CALLTYPE
TABLE STDPRTCT
P351 ( 1) ( 0) 0
    P351 ( 1) ( 0) 0
WARNING: CHANGES IN TABLE STDPRT MAY ALTER OFFICE
BILLING. CALL TYPE DEFAULT IS NP. PLEASE REFER TO
DOCUMENTATION
    . 67 810 N NP 0 NA
    . SUBTABLE AMAPRT
    . KEY NOT FOUND
    . DEFAULT VALUE IS: NONE OVRNONE N
TABLE HNPACONT
619 127 8 ( 26) ( 1) ( 0) ( 0) 0
    . SUBTABLE HNPACODE
    . 675 675 DN 619 675
TABLE TOFCNAME
619 675
TABLE DNINV
619 675 3002 L HOST 00 0 02 16
+++ TRAVER: SUCCESSFUL CALL TRACE +++

DIGIT TRANSLATION ROUTES
1 LINE                6196753002 ST

TREATMENT ROUTES. TREATMENT IS: GNCT
1 NCRTANNC
2 T120

+++ TRAVER: SUCCESSFUL CALL TRACE +++

```

- 5 Determine what type of information should be in a layer 3 Q.931 protocol trace by determining the type of service being provided. The most vital information to check is the number of called digits and the call type. The call type is determined by the values of the NSF (network specific facilities) if the call is ISA (integrated service access), and the NPI (numbering plan indicator). This information must match the far-end.  
Refer to the "ISA troubleshooting" section in the chapter "Trouble isolation and correction methods" for more information about NSF, ISA, and the NPI.
- 6 Perform a layer 3 (Q.931) protocol trace of the failed call to determine what messages are actually being sent.

**Figure 15-2 PMDEBUG data**

```

<== Q931: SETUP:      from S[7051] L[1,90,0]
E[72,89,0]
CR: 0,02 0B
BC: speech
    64 kbit/s
    circuit mode
    mu-law speech
CID:Slot Map/CH#: 81
NSF: private
00
CGN:e164
    national_number
    network_provided
    presentation_allowed
    6196753000
CDN:e164
    local_directory_number
    6753002

==> Q931: REL COM:   to S[7051] L[1,90,0]
E[72,89,0]
CR: 1,02 0B
CSE: user
    incoming_calls_barred
    
```

This protocol trace shows that the NSF is private, the NPI is public, the bearer capability is speech, and seven digits are received as part of the setup message.

- 7 Verify the incoming setup message including the values of the NSF, the NPI, the called digits, and the bearer capability. Further information about the call can be obtained using TRAVER.

Refer to the following table for more information about setup messages.

**Table 15-1**

<b>If the setup message is</b>	<b>Do</b>
correct	step 9
incorrect	step 8

15-4 Troubleshooting example

---

- 8 Make modifications at the far-end equipment to ensure that the proper information is received. When modifications at the far-end are complete, test that the call will complete.

**Table 15-2**

If the call	Do
completes	step 13
does not complete	step 9

- 9 Verify that translations are correct by issuing the proper TRAVER based on the NPI and NSF of the incoming setup message.

*Analysis of the protocol trace showed that the correct information was received based on the call being private. At this point, a TRAVER with options set for private calls can be issued. Note the difference in the following TRAVER command and the first one that was issued.*

**Figure 15-3 Example >traver tr pratest2 n cdn e164 6753002 pvt 0 b**

```
>traver tr pratest2 n cdn e164 6753002 pvt 0 b
```

```
Warning: Routing characteristics are present.  
Originator must be able to send in  
characteristics specified.
```

```
INVALID DATA IN TABLE LTCALLS
```

```
+++ TRAVER: CALL TRACE TERMINATED DUE TO DATA  
TROUBLE +++
```

```
INVALID DATA IN TABLE LTCALLS
```

```
+++ TRAVER: CALL TRACE TERMINATED DUE TO DATA  
TROUBLE +++
```

**Table 15-3**

If datafill is	Do
incorrect	step 10
correct	step 12

- 10 Modify the incorrect translations. Refer to the *ISDN PRI Translations Guide*, 297-2401-360.

In this example, there are missing translations; a tuple in table LTCALLS must be added.

11 Determine if the call will complete.

**Table 15-4**

If the call	Do
completed	step 13
does not complete	step 12

**Figure 15-4 Example >traver tr pratest2 n cdn e164 1 6753002 prvt 0 b**

**>traver tr pratest2 n cdn e164 1 6753002 prvt 0 b**

Warning: Routing characteristics are present.  
Originator must be able to send in  
characteristics specified.

```
TABLE TRKGRP
PRATEST2 PRA 0 NPDGP NCRT ASEQ N (ISDN 1001) $
TABLE LTCALLS
ISDN 1001 PVT XLAIBN 0 BNR 00 $
TABLE LINEATTR
0 1FR NONE NT NSCR 0 619 P351 NLCA RTE4 0 NIL NILSFC
NILLATA 0 NIL NIL 00 Y
LCABILL OFF - BILLING DONE ON BASIS OF CALLTYPE
TABLE STDPRTCT
P351 ( 1) ( 0) 0
. SUBTABLE STDPRT
WARNING: CHANGES IN TABLE STDPRT MAY ALTER OFFICE
BILLING. CALL TYPE DEFAULT IS NP. PLEASE REFER TO
DOCUMENTATION.
. 67 810 N NP 0 NA
. SUBTABLE AMAPRT
. KEY NOT FOUND
. DEFAULT VALUE IS: NONE OVRNONE N
TABLE HNPACONT
619 127 8 ( 26) ( 1) ( 0) ( 0) 0
. SUBTABLE HNPACODE
. 675 675 DN 619 675
TABLE TOFCNAME
619 675
TABLE DNINV
619 675 3002 L HOST 00 0 02 16
```

+++ TRAVER: SUCCESSFUL CALL TRACE +++

DIGIT TRANSLATION ROUTES

1 LINE 6196753002 ST

TREATMENT ROUTES. TREATMENT IS: GNCT

1 NCRTANNC

2 T120

+++ TRAVER: SUCCESSFUL CALL TRACE +++

*A test call confirms that the call does complete, and the following PMDEBUG data is the trace.*

**Figure 15-5 Example DEBEBUG data**

```
<== Q931: SETUP: from S[7051] L[1,90,0] E[72,89,0]
CR:0,02 0D
BC:speech
    64 kbit/s
    circuit mode
    mu-law speech
CID:Slot Map/CH#: 81
NSF:private
00
CGN:e164
    national_number
    network_provided
    presentation_allowed
    6196753000
CDN:e164
    local_directory_number
    6753002

==> Q931: CALL PROC: to S[7051] L[1,90,0] E[72,89,0]
CR:1,02 0D
CID:Slot Map/CH#: 81

==> Q931: ALERT: to S[7051] L[1,90,0] E[72,89,0]
CR:1,02 0D
PI :user
    in_band_info_or_pattern_now_avail

==> Q931: CONN: to S[7051] L[1,90,0] E[72,89,0]
CR: 1,02 0D

==> Q931: CONN ACK: to S[7051] L[1,90,0] E[72,89,0]
CR: 0,02 0D

==> Q931: DISC: to S[7051] L[1,90,0] E[72,89,0]
CR: 1,02 0D
CSE:user
    normal_call_clearing

<== Q931: REL: to S[7051] L[1,90,0] E[72,89,0]
CR: 0,02 0D

<== Q931: REL COM: to S[7051] L[1,90,0] E[72,89,0]
CR: 1,02 0D
```

## 15-8 Troubleshooting example

---

- 12 For further assistance, contact the personnel responsible for the next level of support
- 13 You have completed this procedure.

---

## List of terms

---

**2B1Q**

Two binary one quaternary. The interface standard for ISDN basic rate interface (BRI) transmission between the network and the network termination 1 (NT1) as defined by the American National Standards Institute (ANSI).

**access module (AM)**

The unit that provides access to the network modules (NM) of a digital packet network switching system from a local end user packet data line or the digital interworking unit (DIU).

**access privilege (AP)**

A term used to define bearer services for an ISDN logical terminal. Northern Telecom currently defines four APs: B (circuit-switched voice and data), D (low-speed packet data), PB (high-speed packet-switched data), and BD (circuit-switched voice and low-speed packet-switched data).

**access termination (AT)**

The functional term to describe the part of the exchange termination which terminates the access interfaces (BRI and PRI). It defines the access privileges of the terminals on an interface, and provides the terminals on an interface with access to ISDN circuit- and packet-switching services.

**agent**

*See* telephony agent.

**AM**

*See* access module (AM).

**AMA**

*See* automatic message accounting (AMA).

**AP**

*See* access privilege (AP).



**Automatic message accounting (AMA)**

An automatic recording system that documents all the necessary billing data of end user-defined long distance calls.

**basic rate access functional set (BRAFS)**

An ISDN set that uses functional signaling. The Meridian M5317T is the BRAFS for Northern Telecom. *See also* functional signaling.

**basic rate access key set (BRAKS)**

An ISDN set that uses stimulus signaling. The Meridian M2317T is the BRAKS for Northern Telecom. *See also* functional signaling, stimulus signaling.

**basic rate interface (BRI)**

A type of access to ISDN service provided by a set of time-division multiplexed digital channels of information, including two B-channels, one D-channel, and one or more maintenance channels, often described as 2B (channels) + D (channel). A BRI is typically used on lines between customer premises and a central office switch. Formerly known as basic rate interface (BRA).

**BC**

*See* bearer capability (BC).

**B-channel**

A 64-kbit/s digital bidirectional channel used by ISDN for carrying either circuit-switched voice or data, or packet-switched data.

**Bb**

A B sub-b channel. A 64-kbit/s channel carrying multiplexed B-channel data packets to the packet handler. *See also* B-channel.

**Bd**

A B sub-d channel. A DS-0 channel that carries low-speed, packet-switched data statistically multiplexed from up to 64 different sources. Bd is one of 24 channels on a DS-1 facility between the ET and the PH.

**bearer capability (BC)**

A characteristic associated with a directory number (DN) to indicate the type of call (voice or data) and the rate of transmission that is allowed. Bearer capability is also an information element that is carried in the setup message for functional signaling to indicate the type of call (voice or data) and the rate of transmission required (for ISDN). *See also* authorized call type, bearer services.

**bearer services**

Characteristic that is associated with a logical terminal (service profile) in functional signaling. It offers a pool of bearer capabilities to a logical terminal. Also called authorized call type.

**Bell Communications Research (Bellcore)**

A group responsible for coordinating Bell operating company projects and setting guidelines for a switching system.

**Bellcore**

*See* Bell Communications Research (Bellcore).

**BIC**

*See* bus interface card (BIC).

**B-packet**

Packet data that is transmitted over a B-channel.

**BRAFS**

*See* basic rate access functional signalling (BRAFS).

**BRAKS**

*See* basic rate access key set (BRAKS).

**BRAMFT**

basic rate access Meridian functional signalling (BRAMFT).

**BRI**

*See* basic rate interface (BRI).

**bus interface card (BIC)**

A hardware interface that connects two 32-channel digroups to a maximum of 64 line cards. This card is located in the drawer of the line concentrating module (LCM).

**B-voice**

A pulse code modulated voice signal carried on a B-channel.

**calling line identification (CLI)**

In data transmission, a feature provided by the network that allows a called terminal to be notified by the network of the address from which the call has originated. Screening of CLI is performed during call setup only.

**call processing**

The software that handles the processes involved in setting up connections through the DMS-100 Family network between calling and called parties.

**call reference**

This identifies the call on the local ISDN interface to which the message applies. Stimulus call control messages have dummy call references because the network controls the call. Functional call control messages are used by the ISDN terminal to distinguish between call appearances of the same directory number, and to selectively control a number of simultaneous calls (for example, an active call, calls on hold, calls waiting).

**call type**

*See* authorized call type *and* bearer services.

**CCC**

*See* central control complex (CCC).

**CCITT**

*See* Consultative Committee on International Telephony and Telegraphy (CCITT).

**CCS7**

*See* Common Channel Signaling 7 (CCS7).

**central control complex (CCC)**

The part of the DMS-100 Family switch that contains all the current control (CC) functions including the central message controller (CMC), CPU, program store (PS), and data store (DS).

**central office (CO)**

A switching office (SO) arranged for terminating end user lines and provided with switching equipment and trunks for establishing connections to and from other SOs. Also known as a local office.

**CLI**

*See* calling line identification (CLI).

**Common Channel Signaling 7 (CCS7)**

A digital message-based network signaling standard, defined by the CCITT, that separates call signaling information from voice channels so that interoffice signaling is exchanged over a separate signaling link.

**CDTE**

ISDN cabinetized digital trunk equipment

**central side (C-side)**

The side of a node that faces away from the peripheral modules (PM) and toward the central control (CC). Also known as control side. *See also* peripheral side (P-side).

**channel supervision message (CSM)**

A message received and transmitted continuously on each connected voice channel of a peripheral module. The CSM contains a connection data byte, which includes the channel supervision bit, and an integrity byte, which issues call path integrity.

**circuit-switched network**

Synonym for the telephone network.

**CLGE**

ISDN cabinetized line group equipment

**CLMI**

Cabinetized line module ISDN

**CO**

*See* central office (CO).

**Consultative Committee on International Telephony and Telegraphy (CCITT)**

The CCITT is one of the four permanent groups within the International Telecommunication Union (ITU). The CCITT is responsible for studying technical, operating, and tariff questions. This organization also prepares recommendations relating to telephony and telegraphy, including data and program services.

**CPE**

*See* customer premises equipment (CPE).

**CS-data**

Circuit-switched data carried on B-channel

**C-side**

*See* central side (C-side).

**CSM**

*See* channel supervision message (CSM).

**customer premises equipment (CPE)**

Equipment, such as ISDN terminals, that is located on the customer's premises.

**data link layer**

Layer 2 in the open systems interconnection (OSI) model that is used to create logical links between ISDN terminals and the services they access. The datalink layer provides error-free, sequenced messaging over a channel.

**data network address (DNA)**

A number that accesses a terminal on the packet-switched network.

**data network identification code (DNIC)**

For ISDN, a code that is used in packet switching to identify the network being addressed.

**data packet network (DPN)**

A packet-switched networking system that is manufactured by Northern Telecom.

**data store (DS)**

One of the two distinct elements of a DMS-100 memory, DS is part of the central control complex (CCC). It contains transient information for each call as well as customer data and office parameters. The other main element of a DMS-100 memory is program store (PS). *See also* program store (PS), protected store (PROT).

**D-call control**

Call control information that is carried on the D-channel and used to establish, maintain, or clear a voice or circuit-switched data call on a B-channel of an ISDN.

**DCC**

*See* digroup control card (DCC).

**DCH**

*See* D-channel handler (DCH).

**D-channel**

For BRI, the D-channel is a 16 kbit/s, bi-directional channel. A D-channel carries call control messages between a terminal on an ISDN interface and the exchange termination. These call control messages are used to set up, maintain, or clear a circuit-switched call on a B-channel. The D-channel also carries low-speed packet data between a terminal on an ISDN interface and a terminal in the packet data network. For PRI, the D-channel is a 64 kbit/s, bi-directional channel. *See also* Bd channel, BRI, PRI.

**D-channel handler (DCH)**

A card in an ISDN line group controller (LGCI) or in an ISDN line trunk controller (LTCI) that provides the primary interface to all D-channels. The DCH also performs Q.921 LAPD layer 2 processing. The DCH is assigned to an ISDN loop and receives or sends messages on the signaling/packet data channel.

**digital interworking unit (DIU)**

The unit in a digital packet network switch that converts B-channel and D-channel data packets received in a DS-1 format from the ISDN access controller to a VR-35 format that is suitable for the access module. For packets being sent in the opposite direction, the DIU performs the reverse conversion.

**digroup control card (DCC)**

A circuit that makes up part of the line concentrating module (LCM) unit control complex. DCC provides eight DS30A ports for connection to the network in the host LCM or to the host interface equipment (HIE) shelf in the remote line concentrating module (RLCM).

**direct memory access (DMA)**

A device for moving blocks of continuous data to and from memory at a high rate.

**directory number (DN)**

The full complement of digits required to designate a end user's station within one numbering plan area (NPA)—usually a three-digit central office code followed by a four-digit station number.

**DIU**

*See* digital interworking unit (DIU).

**DMA**

*See* direct memory access (DMA).

**DMS PH**

DMS packet handler

**DN**

*See* directory number (DN).

**DNA**

*See* data network address (DNA).

**DNIC**

*See* data network identification code (DNIC).

**D-packet**

Packet data carried on the D-channel between the packet handler and an ISDN terminal.

**DPN**

*See* data packet network (DPN).

**DS**

*See* data store (DS).

**DS-0**

A protocol for data transmission that is used to represent one channel in a 24-channel DS-1 trunk.

**DS-1**

A closely specified bipolar pulse stream with a bit rate of 1.544 Mbit/s. It is the standard signal used to interconnect Northern Telecom digital systems. The DS-1 signal carries 24 DS-0 information channels of 64 kbit/s each.

**DS30 link**

1. A 10-bit, 32-channel, 2.048-Mbit/s speech-signaling and message-signaling link as used in the DMS-100 Family. 2. The protocol by which DS30 links communicate.

**DS30A link**

A 32-channel transmission link between the line concentrating module and controllers in the DMS-100 Family. DS30A is similar to DS30, though intended for use over shorter distances.

**DTCI**

*See* ISDN digital trunk controller (DTCI).

**DTCOi**

*See* ISDN digital trunk controller offshore (DTCOi).

**DTEI**

*See* ISDN digital trunk equipment frame (DTEI).

**E.164**

The public network numbering plan in accordance with CCITT Recommendation E.164.

**EAEO**

*See* equal access end office.

**EISP**

*See* enhanced ISDN signaling preprocessor (EISP).

**EKTS**

*See* electronic key telephone service (EKTS).

**electronic key telephone service (EKTS)**

A set of services for ISDN voice terminals on a basic rate interface. EKTS provides shared directory numbers (DN), multiple DNs for each service profile, and conference and intercom calling.

**end office (EO)**

A switching office (SO) arranged for terminating end user lines and provided with trunks for establishing connections to and from other SOs. *See also* central office (CO).

**enhanced ISDN signaling preprocessor (EISP)**

Provides call control messaging and D-channel handler maintenance functions, similar to the ISP, but with memory upgrade from 1 Mbyte to 4 Mbyte, clock speed upgrade from 16 MHz to 20 MHz, and data bus upgrade from a 16 bit width to 32 bits.

**enhanced line concentrating module (LCME)**

A dual-unit peripheral module that terminates ISDN 2B1Q U-type lines, ISDN S/T-type lines, plain ordinary telephone service (POTS), electronic business sets (EBS), and Datapath lines. LCME also provides access to the ISDN B-, D-, and M-channels. The LCME supports 480 POTS, EBS, or ISDN U- lines, or 240 Datapath or S/T- lines.

**enhanced service provider (ESP)**

A third-party vendor that supplies value-added services to the end user.

**enhanced services test unit (ESTU)**

A stand-alone test unit that performs metallic and digital line tests at remote or host sites for ISDN services.

**EO**

*See* end office (EO).

**equal access end office**

A central office that provides access to several long distance carriers.

**ESP**

*See* enhanced service provider (ESP).

**ESTU**

*See* enhanced services test unit (ESTU).

**ET**

*See* exchange termination (ET).

**ETSI**

European Telecommunications Standards Institute



**exchange termination (ET)**

The functional name for the component of the ISDN that serves as the access termination for BRI and PRI interfaces, and provides circuit-switched services to the ISDN switch.

**F-bus**

*See* frame transport bus.

**feature indicator (FI)**

A device that indicates the state or condition of a call when using a supplementary service on an ISDN stimulus terminal with circuit-switched service.

**FI**

*See* feature indicator (FI).

**foreign exchange (FX)**

A service that allows a telephone or a PBX to be served by a distant central office (CO), rather than by the CO in the immediate geographical area.

**frame transport bus (F-bus)**

An eight-bit bus that provides data communications between a local message switch (LMS) and the link interface units that are provisioned in a link peripheral processor (LPP). To ensure readability, two load-sharing F-buses are provided in an LPP. Each F-bus is dedicated to one of the two LMSs. *See also* link interface module.

**functional signaling**

An intelligent terminal in which call control functions are shared between the switch and the terminal.

**FX**

*See* foreign exchange (FX).

**HFP**

HDLC frame processor

**HIE**

*See* host interface equipment (HIE).

**high-level data link control**

The channel by which high-level control messages from the central control are carried between the digital carrier module and remote line modules.

**host interface equipment (HIE) shelf**

In the remote line concentrating module (RLCM) frame, this shelf provides interface circuits between the host office and the RLCM.

**IBERT**

*See* integrated bit error rate test (IBERT).

**IEC**

Inter-exchange carrier

**initial program load (IPL)**

The initialization procedure that causes a computer operating system to start operation.

**integrated bit error rate test (IBERT)**

A test that a MAP operator uses with an IBERT card to test the transmission quality of a selected data line. The card resides in the line drawer of a line concentrating module and generates the bit stream for an IBERT.

**integrated services access (ISA)**

Uses call setup messages and dialed digits to permit access to public and private network services through one bidirectional common access facility. ISA provides the capability to support multiple call types (such as PUBLIC, PRIVATE, OUTWATS, INWATS, FX, and TIE) on a single trunk.

**integrated services digital network (ISDN)**

A set of standards proposed by the CCITT to establish compatibility between the telephone network and various data terminals and devices. ISDN is a communications network that provides access to voice, data, and imaging services from a single type of connector.

**inter-LATA**

Telecommunications services, revenues, and functions that originate in one local access and transport area (LATA) and terminate either outside that LATA or inside another LATA.

**International Standards Organization (ISO)**

The organization responsible for creating a seven-layer protocol model for a data communications network.

**intra-LATA**

Telecommunication services, revenues, and functions that originate in one local access and transport area (LATA) and terminate either outside that LATA or inside another LATA.

**IPL**

*See* initial program load.

**ISA**

*See* integrated services access (ISA).

**ISDN**

*See* integrated services digital network (ISDN).

**ISDN access controller**

A frame used to support ISDN access between a DMS and voice and packet services.

**ISDN digital trunk controller (DTCI)**

A dual-unit peripheral module that provides access for ISDN primary rate interface to a digital private branch exchange (PBX). The DTCI provides call control for PRI functional signaling, and performs functions similar to the LGC, including D-channel handling and processing, and maintenance and diagnostics.

**ISDN digital trunk controller offshore (DTCOi)**

A peripheral module (PM) that connects DS30 links from the network with digital trunk circuits with ISDN.

**ISDN digital trunk equipment (DTEI) frame**

A frame containing up to two dual-shelf ISDN digital trunk controllers.

**ISDN line**

The physical part of a basic rate interface (BRI) that connects the terminals to the network termination (NT1).

**ISDN line concentrating array (LCAI)**

A shelf in the ISDN line concentrating module (LCME). It contains four physical line drawers. The LCME consists of two line concentrating arrays, which operate in a load sharing mode with mutual takeover capability.

**ISDN line concentrating equipment (LCEI)**

A single-bay equipment frame containing two LCMEs.

**ISDN line group controller (LGCI)**

A peripheral module that connects DS30 links from the network.

**ISDN line trunk controller (LTCI)**

A peripheral module that is a combination of the line group controller and the digital trunk controller, and provides all of the services offered by both.

**ISDN service group (ISG)**

Defines the services that a D-channel handler (DCH) provides and their allocation to the channels within the DCH. ISG allows hardware-independent access to service-related functions at the MAP. The ISG MAP level provides a view of the services and the DCH MAP level provides a view of the hardware.

**ISDN signaling preprocessor (ISP)**

Provides call control messaging and D-channel handler maintenance functions.

**ISDN switch**

A DMS switch configured to provide ISDN services. Its main functional components are the exchange termination and the packet handler.

**ISDN terminal**

A digital telephone or personal computer that is connected to a customer premises loop which forms part of a BRI.

**ISDN U-line card (U-ISLC)**

An ISDN line card which terminates the U-loop in the enhanced line concentration module (LCME). When a U-ISLC is used, the network termination 1 (NT1) situated on customer premises acts as the network termination. Synonymous with ISLC and U-line card.

**ISDN user part (ISUP)**

A CCS7 message-based signaling protocol which acts as a transport carrier for ISDN services. The ISUP provides the functionality within a CCS7 network for voice and data services.

**ISG**

*See* ISDN service group (ISG).

**ISLC**

*See* ISDN U-line card (ISLC).

**ISO**

*See* International Standards Organization (ISO).

**ISP**

*See* ISDN signaling preprocessor (ISP).

**ISUP**

*See* ISDN user part (ISUP).

**kbit/s**

*See* kilobits per second (kbit/s).

**kilobits per second (kbit/s)**

A bit rate expressed in thousands of bits per second.

**LAPB**

*See* link access procedure balanced (LAPB).

**LAPD**

*See* link access procedure on the D-channel (LAPD).

**LATA**

*See* local access and transport area (LATA).

**L-bus**

A bi-directional link that acts as the interface between the bus interface card and the line card in an enhanced line concentrating module (LCME).

**LC**

*See* line circuit (LC).

**LCAI**

*See* ISDN line concentrating array (LCAI).

**LCC**

*See* Line Class Code (LCC).

**LCEI**

*See* ISDN line concentrating equipment (LCEI).

**LCM**

*See* line concentrating module (LCM).

**LCME**

*See* enhanced line concentrating module (LCME).

**LD**

*See* line drawer (LD).

**LEN**

*See* line equipment number (LEN).

**LGC**

*See* line group controller (LGC).

**LGCI**

*See* ISDN line group controller (LGCI).

**LIM**

*See* link interface module.

**line circuit (LC)**

A hardware device that provides an interface between end user lines and the digital switch. Each end user line has a dedicated line circuit. *See also* line drawer (LD).

**Line Class Code (LCC)**

An alphanumeric code that identifies the class of service assigned to a line.

**line concentrating module (LCM)**

A peripheral module which interfaces the line trunk controller or line group controller and up to 640 end user lines, using two to six DS30A links.

**line drawer (LD)**

A hardware entity located in the LCME that contains line circuit cards.

**line equipment number (LEN)**

A seven-digit function-reference used to identify line circuits.

**line group controller (LGC)**

A peripheral module that connects DS30 links from the network to the LCME.

**line trunk controller (LTC)**

A peripheral module that is a combination of the line group controller and the digital trunk controller, and provides all the services offered by both.

**link access procedure balanced (LAPB)**

ISDN access protocol that is used with links established on a B-channel. LAPB supports a single data link that operates with a fixed, single-byte address convention between the ISDN terminal and the network.

**link access procedure on the D-channel (LAPD)**

ISDN access protocol that is used with links established on a D-channel.

**link interface module (LIM)**

A peripheral module that controls messaging between link interface units (LIU) in a link peripheral processor (LPP). The LIM also controls messages between the LPP and the DMS-bus. An LIM consists of two local message switches (LMS) and two frame transport buses (F-bus). One LMS normally operates in a load sharing mode with the other LMS. This ensures LIM reliability in the event of an LMS failure because each LMS has adequate capacity to carry the full message load of an LPP. Each LMS uses a dedicated F-bus to communicate with the LIUs in the LPP.

**link interface unit (LIU)**

A peripheral module that processes messages entering and leaving a link peripheral processor through an individual signaling data link. *See also* CCS7 link interface unit 7.

**link peripheral processor (LPP)**

The DMS SuperNode equipment frame for DMS-STP that contains two types of peripheral modules: an LIM and an LIU. For DMS-STP

applications, CCS7 link interface units 7 (LIU7) are used in the LPP. *See also* link interface module.

**LIU**

*See* link interface unit (LIU).

**local access and transport area (LATA)**

A geographic area within which an operating company may offer telecommunications-related services. *See also* inter-LATA and intra-LATA.

**logical terminal (LT)**

The datafilled instance of an abstract terminal that is provided with a subset of the features and services (service profile) datafilled in the access termination for the abstract terminal.

**logical terminal identifier (LTID)**

The unique identifier that is assigned to a logical terminal when it is datafilled in the ISDN access termination.

**LPP**

*See* link peripheral processor (LPP).

**LTC**

*See* line trunk controller (LTC).

**LTCI**

*See* ISDN line trunk controller (LTCI).

**LTID**

*See* logical terminal identifier (LTID).

**maintenance trunk module (MTM)**

In a trunk module equipment (TME) frame, a peripheral module (PM) that is equipped with test and service circuit cards and contains special buses to accommodate test cards for maintenance. The MTM provides an interface between the DMS-100 Family digital network and the test and service circuits.

**MAP**

The maintenance and administration position. MAP is a group of components that provides a user interface between operating company personnel and the DMS-100 Family systems. A MAP consists of a visual display unit and keyboard, a voice communications module, test facilities, and MAP furniture. MAP is a trademark of Northern Telecom.

**Mbit/s**

*See* megabits per second (Mbit/s).

**M-channel**

A 16-kbit/s, bi-directional, U-loop channel used to transfer maintenance information between the NT1 and the exchange termination.

**megabits per second (Mbit/s)**

Expresses the rate of transmission of serial data bits in a time-division multiplexed frame format.

**MTM**

*See* maintenance trunk module (MTM).

**NAS**

*See* network administration system (NAS).

**network administration system (NAS)**

A stand-alone computer that is involved in operation, administration, and maintenance for integrated services digital network (ISDN) services. The NAS uses data on service and system operation to generate files that contain information on alarms, accounting, billing, and network operation.

**network interface unit**

A DMS SuperNode application specific unit (ASU) that provides channelized access for F-bus resident link interface units (LIU) using a channel bus (C-bus). The NIU resides in a link peripheral processor (LPP) frame.

**network layer**

Layer 3 in the OSI model. In ISDN, the network layer is used to send call control messages.

**network modules (NM)**

The basic building block of the DMS-100 Family switches. The NM accepts incoming calls and uses connection instructions from the central control complex (CCC) to connect the incoming calls to the appropriate outgoing channels. Network module controllers control the activities in the NM.

**network termination 1 (NT1)**

Access point for basic rate interface to ISDN. This component is situated on customer premises and is typically located between the terminals and the exchange termination. An NT1 is required when ISDN lines are terminated by U-line cards.

**NIU**

*See* network interface unit.



**NT1**

*See* network termination 1 (NT1).

**NTP**

Northern Telecom Publication

**open system interconnection (OSI)**

A 7-layer protocol model for communications networks developed by the International Standards Organization and adopted by the Consultative Committee on International Telephony and Telegraphy (CCITT) for an Integrated Services Digital Network (ISDN).

**OSI**

*See* open system interconnection (OSI).

**packet handler (PH)**

The CCITT term for the component of an ISDN switch that provides packet switching services.

**PCM**

*See* pulse code modulation (PCM).

**PCM30 digital trunk controller (PDTC)**

A digital trunk interface that has the hardware configuration of an international digital trunk controller (IDTC) but runs the software of a digital trunk controller (DTC).

**PCM30**

A 32-channel 2.048-Mbit/s speech-signaling and message-signaling link used in international trunks.

**PDTC**

*See* PCM30 digital trunk controller (PDTC).

**peripheral module (PM)**

A generic term referring to all hardware modules of DMS-100 Family systems that provide interfaces with external line, trunk, or service facilities. A PM contains peripheral processors, which perform local routines, thus relieving the load on the central processing unit.

**peripheral side (P-side)**

The side of a node facing away from the central control and towards the peripheral modules. *See also* central side (C-side).

**permanent virtual circuit (PVC)**

A continuously available virtual path between remote applications and DMS applications. The PVC eliminates the need to establish a circuit on an each call basis.

**per trunk signaling (PTS)**

Conventional telephony method, which multiplexes a call's control signals with voice or data over the same trunk.

**PH**

*See* packet handler (PH).

**PM**

*See* peripheral module (PM).

**point-of-use power supply (PUPS)**

The type of power supply used for an enhanced line concentrating module (LCME). It provides 5V power supply for ISDN line cards. There is one PUPs for each line drawer.

**PPSN**

*See* public packet-switched network (PPSN).

**PRI**

*See* primary rate interface (PRI).

**primary rate interface (PRI)**

An interface that carries nB+D channels over a PCM30 digital facility (generally 30B+D for ETSI PRI). PRI is used to link private networking facilities, such as private branch exchanges (PBX), local area networks (LAN), and host computers with a standardized architecture acting as the bridge between private switching equipment and the public network. Formerly known as primary rate access (PRA).

**product engineering code**

An 8-character code that provides a unique identification for each marketable product manufactured by Northern Telecom.

**program store (PS)**

In a DMS-100 switch, programmed instructions for the various procedures required to perform processing, administration, and maintenance. Program store is one of the two distinct elements of a DMS-100 memory. The other main element is data store. *See* also data store (DS), protected store (PROT).

**PROT**

*See* protected store (PROT).

**protected store (PROT)**

In a DMS-100 switch, store type (program or data) that must be explicitly unprotected before any write operation and protected again afterward. This type of store remains allocated and its contents remain intact over all restarts except initial program load (IPL). Protected store is used to hold the office database and translation data equipment configurations. *See also* data store (DS), program store (PS).

**PS**

*See* program store (PS).

**PSDS**

*See* public switched data service (PSDS).

**P-side**

*See* peripheral side (P-side).

**PTS**

*See* per trunk signaling (PTS).

**public packet switched network (PPSN)**

Any common carrier network designed to carry data in the form of packets between public users.

**public switched data service (PSDS)**

Any common carrier network designed to switch data, not necessarily in packet form, between public users.

**pulse code modulation (PCM)**

Representation of an analog waveform by coding and quantizing periodic samples of the signal, so that each element of information consists of a binary number representing the value of the sample.

**PUPS**

*See* point-of-use power supply (PUPS).

**PVC**

*See* permanent virtual circuit (PVC).

**Q.921**

The CCITT recommendation that defines protocols at the datalink layer.

**Q.931**

The CCITT recommendation that defines protocols for circuit-switched call control at the network layer.

**remote line concentrating module (RLCM)**

An equipment frame that provides an interface between two to six DS-1 links (from the line group controller LGC) at the host office) and up to 640 end user lines (connected locally). An RLCM is equipped with one line concentrating module (LCM), a remote maintenance module (RMM), and a host interface equipment (HIE) shelf.

**remote maintenance module (RMM)**

A peripheral module (PM) with a configuration similar to that of the maintenance trunk module (MTM). An RMM accommodates up to 12 service and test cards.

**RLCM**

*See* remote line concentrating module (RLCM).

**RMM**

*See* remote maintenance module (RMM).

**SAPI**

*See* service access point identifier (SAPI).

**service access point identifier (SAPI)**

Identifier that is used by datalink layer (layer 2) protocol to define the type of service allowed to an ISDN terminal.

**signaling processor (SP)**

The interface between a master processor and the control circuits in the line-side of a line module. Through the SP, the line circuits, ringing multiplexers, programmable ringing generators, and the activity circuit are controlled, and their status reported.

**SO**

*See* switching office (SO).

**SP**

*See* signaling processor (SP).

**S/T bus**

An eight-wire bus (of which only four wires are used to transmit and receive messages) that connects terminals to the NT1 for access to the ISDN. Also known as an S/T-interface and an S/T-loop. Formerly known as a T-bus.

**stimulus signaling**

For ISDN call control, stimulus signaling mode messages for call control are sent by the terminal to the network as a direct result of actions by the terminal user. Terminals that use stimulus signaling have little local

intelligence and are driven by the network. These terminals do not keep records of call states. *See also* functional signaling.

**S/T-interface**

CCITT name for the S/T-bus.

**S/T-line card**

An ISDN line card that terminates the S/T-bus in the LCME. When S/T-line cards are used, the U-interface and the NT1 are not required. The exchange termination acts as a network termination. *See also* U-line card.

**switching office (SO)**

A node in the Common Channel Signaling 7 (CCS7) network that originates and terminates signaling messages related to the set up and take down of associated ISDN user part (ISUP) trunks.

**TA**

*See* terminal adapter (TA).

**telephony agent**

Any kind of line, trunk, or special service circuit that performs a telephony function. *See also* agent.

**terminal adapter**

A device with associated software that allows a personal computer to connect to a Northern Telecom ISDN.

**TME**

*See* trunk module equipment (TME) frame.

**trunk module equipment (TME) frame**

A frame containing one or more trunk modules (TM), maintenance trunk modules (MTM), or office alarm units (OAU).

**U-interface**

The CCITT term for a U-loop. *See also* U-loop.

**U-line card**

ISDN line card that terminates the U-loop in the LCME. When U-line cards are used, the NT1, situated on customer premises, acts as the network termination.

**U-loop**

The portion of a BRI that connects an NT1 to an ISDN line concentrating module or an enhanced line concentrating module (LCME). *See also* U-interface.

**unified processor (UP)**

A processor that replaces the master processor (MP), signaling processor (SP), and the memory cards associated with these processors.

**universal terminal adapter (UTA)**

A device with associated software that allows non-ISDN devices such as personal computers to connect to a Northern Telecom ISDN line.

**UP**

*See* unified processor.

**VC**

*See* virtual circuit.

**virtual circuit**

In packet switching, a network facility used for transferring data between those data stations emulating physically-connected stations.

**X.31**

CCITT recommendation for support of terminal equipment by ISDN

**X.121**

CCITT standard for data network address

**XMS-based peripheral module (XPM)**

The generic name for peripheral modules (PM) that use the Motorola 68000 microprocessor. An XPM has two processors in a hot-standby configuration: a master processor (MP) and a signaling processor (SP).

**XPM**

*See* XMS-based peripheral module (XPM).

**XPM Plus**

XMS-based peripheral module that uses enhanced hardware and software







DMS-100 Family

## **ISDN Primary Rate Interface**

### ISDN Primary Rate Interface Service Implementation Guide

Product Documentation-Dept. 3423

Nortel Networks

PO Box 13010

RTP, NC 27708-3010

Telephone: 1-877-662-5669

Electronic mail: [cits@nortelnetworks.com](mailto:cits@nortelnetworks.com)

Copyright © 1998-2000 Nortel Networks,

All Rights Reserved

**NORTEL NETWORKS CONFIDENTIAL:** The information contained herein is the property of Nortel Networks and is strictly confidential. Except as expressly authorized in writing by Nortel Networks, the holder shall keep all information contained herein confidential, shall disclose the information only to its employees with a need to know, and shall protect the information, in whole or in part, from disclosure and dissemination to third parties with the same degree of care it uses to protect its own confidential information, but with no less than reasonable care. Except as expressly authorized in writing by Nortel Networks, the holder is granted no rights to use the information contained herein.

Information is subject to change without notice. Nortel Networks reserves the right to make changes in design or components as progress in engineering and manufacturing may warrant. Changes or modification to the DMS-100 without the express consent of Nortel Networks may void its warranty and void the users authority to operate the equipment.

Nortel Networks, the Nortel Networks logo, the Globemark, How the World Shares Ideas, Unified Networks, DMS, DMS-100, Helmsman, MAP, Meridian, Nortel, Northern Telecom, NT, SuperNode, and TOPS are trademarks of Nortel Networks.

Publication number: 297-2401-200

Product release: CNA14 and up

Document release: Standard 08.01

Date: September 2000

Printed in the United States of America