

# Critical Release Notice

**Publication number: 297-2631-101**  
**Publication release: Standard 01.03**

The content of this customer NTP supports the  
SN06 (DMS) software release.

Bookmarks used in this NTP highlight the changes between the baseline NTP and the current release. The bookmarks provided are color-coded to identify release-specific content changes. NTP volumes that do not contain bookmarks indicate that the baseline NTP remains unchanged and is valid for the current release.

## Bookmark Color Legend

**Black:** Applies to new or modified content for the baseline NTP that is valid through the current release.

**Red:** Applies to new or modified content for NA017 that is valid through the current release.

**Blue:** Applies to new or modified content for NA018 (SN05 DMS) that is valid through the current release.

**Green:** Applies to new or modified content for SN06 (DMS) that is valid through the current release.

*Attention!*

*Adobe® Acrobat® Reader™ 5.0 is required to view bookmarks in color.*

## **Publication History**

### **March 2004**

Standard release 01.03 for software release SN06 (DMS).

Change of phone number from 1-800-684-2273 to 1-877-662-5669, Option 4 + 1.

297-2631-101

Digital Switching Systems

# UCS DMS-250

## Operator Services Interface Specification

UCS05 Standard 01.02 February 1997

---



---

Digital Switching Systems

# UCS DMS-250

## Operator Services Interface Specification

---

Publication number: 297-2631-101

Product release: UCS05

Document release: Standard 01.02

Date: February 1997

---

© 1996, 1997 Northern Telecom

All rights reserved

Printed in the United States of America

**NORTHERN TELECOM CONFIDENTIAL:** The information contained in this document is the property of Northern Telecom. Except as specifically authorized in writing by Northern Telecom, the holder of this document shall keep the information contained herein confidential and shall protect same in whole or in part from disclosure and dissemination to third parties and use same for evaluation, operation, and maintenance purposes only.

Information is subject to change without notice. Northern Telecom reserves the right to make changes in design or components as progress in engineering and manufacturing may warrant.

DMS, DMS-250, SuperNode, MAP, Nortel, NT, and TOPS are trademarks of Northern Telecom.

---



---

## Publication history

---

### February 1997

Standard release 01.02 for software release UCS05 (CSP04).

This edition was up-issued to incorporate editorial changes to meet current documentation standards. There were no technical changes from the previous edition of this document.

### July 1996

Standard release 01.01 for software release UCS05 (CSP04). This document replaces the *DMS-250 Operator Services Interface Specification*, 297-2621-550.

UCS05 (CSP04) modifications made to the protocol included the addition of `Start_of_Call` and `End_of_Call` messages. This allowed two one-way protocols to co-exist.





---

# Contents

---

<b>About this document</b>	<b>vii</b>
Intended audience	vii
How this document is organized	vii
How to check the version and issue of this document	viii
Document conventions	viii
<hr/>	
<b>Introduction</b>	<b>1-1</b>
Communication purpose	1-1
<hr/>	
<b>Protocol from the UCS DMS-250 switch to the workstation</b>	<b>2-1</b>
Overview	2-1
Control codes	2-1
Table entry number	2-1
Switch to workstation message	2-3
Switch to workstation stored text definitions	2-5
<hr/>	
<b>Protocol from the workstation to the UCS DMS-250 switch</b>	<b>3-1</b>
Overview of workstation message	3-1
Messages listed by message value	3-1
Keyname cross reference	3-8
<hr/>	
<b>Hints and examples</b>	<b>4-1</b>
Considerations regarding data transmission	4-1
Delay of 0.2 seconds may be needed	4-1
Methods to determine end of data	4-1
Other considerations and cautions	4-1
Protocol examples	4-2
SIGN_ON sequence	4-2
SIGN_OFF sequence	4-3
0+ call arrival	4-4
Enter a calling card as special billing number	4-5
Normal call release	4-6
Cancel call release	4-7
<hr/>	
<b>List of terms</b>	<b>5-1</b>



---

# About this document

---

This document describes the data transmission protocol between the UCS DMS-250 switch and the Operator Services workstation.

## Intended audience

This document assists telecommunications engineers, technicians, switching system developers, operating company personnel, and anyone else who requires technical information on the data transmission protocol between the UCS DMS-250 switch and the Operator Services workstation.

## How this document is organized

The chapters in this document provide the following:

### **Chapter 1, Introduction**

Chapter 1 discusses the purpose of the communication and describes modifications to the previous protocol.

### **Chapter 2, Protocol from the UCS DMS-250 switch to the workstation**

Chapter 2 describes the messages and the stored text definitions sent from the UCS DMS-250 switch to the workstation.

### **Chapter 3, Protocol from the workstation to the UCS DMS-250 switch**

Chapter 3 describes the messages sent from the workstation to the UCS DMS-250 switch. Keyname cross references are included.

### **Chapter 4, Hints and examples**

Chapter 4 provides some considerations and hints regarding data transmission. Graphic examples of data transmission are given for the SIGN\_ON sequence, the SIGN\_OFF sequence, the 0+ call arrival, the entering of a calling card as a special number, the normal call release, and the cancel call release.

## How to check the version and issue of this document

The version and issue of the document are indicated by numbers, for example, 01.01.

The first two digits indicate the version. The version number increases each time the document is updated to support a new software release. For example, the first release of a document is 01.01. In the second software release cycle, the first release of the same document is 02.01.

The second two digits indicate the issue. The issue number increases each time the document is revised but re-released in the *same* software release cycle. For example, the second release of a document in the first software release cycle is 01.02.

To determine which version of this document applies to the software in your office and how documentation for your product is organized, check the release information in *UCS DMS-250 Master Index*, 297-2621-001.

This document is written for all UCS DMS-250 offices. More than one version of this document may exist. To determine whether you have the latest version of this document and how documentation for your product is organized, check the release information in *Product Documentation Directory*, 297-8991-001.

## Document conventions

All values are in hexadecimal unless noted in the text or unless noted by a “d” (to indicate decimal) following the number.

A message sequence is shown between < > brackets for clarity.

Variable data within a message sequence is shown within [ ] brackets.

It is assumed that the reader of this document is familiar with the Operator Services offering of Northern Telecom (Nortel).

The term “switch” in this document refers to the UCS DMS-250 switch. The term “workstation” in this document refers to the Operator Services workstation.

---

# Introduction

---

This document describes the data transmission protocol between the UCS DMS-250 switch and the Operator Services workstation.

## Communication purpose

The sole purpose of sending data from the UCS DMS-250 switch to the Operator Services workstation is to display information on the operator's screen. Data from the workstation to the switch directly reflects keystrokes entered by the operator.

The one exception to this is a simple sanity check from the switch asking if the operator's headset is plugged in, to which an automatic reply is generated by the hardware.



---

# Protocol from the UCS DMS-250 switch to the workstation

---

This section describes the messages and the stored text definitions sent from the UCS DMS-250 switch to the Operator Services workstation.

## Overview

The following paragraphs provide an overview of control codes and table entry numbers.

### Control codes

All message fields are one byte in length; most messages are composed of a control code only. The values from 01 to 1F are control codes. They define an action to be taken at the workstation. Some control codes are followed by a fixed number of data fields. For example, control code 17 (set cursor position) is followed by two bytes of data for the column and row. Data received that is not a control code or is not part of a control sequence is displayed directly to the screen at the last cursor position. For example, the sequence <17 32 01 31 30> sets the cursor at column 50d in row 1 and displays “10.” The switch then expects the cursor position to be column 52d in row 1, having been incremented for the two displayed characters.

### Table entry number

Much of the text displayed to an operator is repetitious. To reduce communication line activity, this text is stored in a table accessible to the operator terminal. The text is displayed and erased by reference to the table entry number that defines it.

For example, the sequence <1D 3E 4A 4F 48 4E> requests that stored text in table entry 3E be displayed to the screen at the cursor position indicated in the table entry. Table entry 3E contains the text “NAME”, the start column and row (14d,12d), and whether the field is protected.

**Note:** “Protected” fields are key fields that are left untouched when certain control codes are sent to the workstation to clear unprotected data on the operator’s screen.

## 2-2 Protocol from the UCS DMS-250 switch to the workstation

---

After the stored text is displayed, the cursor is set at column 14d row 12d (14d,12d). The four ASCII characters <4A 4F 48 4E> following are displayed starting at the new cursor location for a screen appearance of "NAME JOHN".

The field may be erased by the sequence <19 3E>. This sequence means "erase the screen area associated with table entry 3E." The length of the field to be erased is defined in the table as nine characters starting at cursor location (0,2). The length of nine characters will cover the stored label "NAME" plus four characters of associated data.



## Switch to workstation message

Table 2-1 describes the messages sent from the switch to the workstation in order by message.

**Table 2-1**  
**Switch to workstation messages**

Value	Meaning/Description
01	Move cursor one position right.
02	Move cursor one position left.
03	End of call. Received when the switch acknowledges all required data has been received and the workstation is released from the call.
04	Terminate a sequence of protected characters. Ends a sequence of characters that began with control code 05.
05	Protected format begins. Begins a sequence of characters that are not to be erased if a control code 15 or 1A is received. This sequence is terminated by control code 04.
06	Clear line (including protected characters) from the cursor to the end of line.
07	Not used.
08	Loop begin. Loop both the voice and data paths back to the switch.
09	Loop end. De-energize the loop relay.
0A	Move the cursor down one line.
0B	Send status. This is a sanity check; the switch expects a response of 11 if the workstation is signed on, or 12 if it is not.
0C	Not used.
0D	Move cursor to the first unprotected position in the same row.
<0E [d1]>	Flash stored text at the current cursor location. d1 = table entry number (00 to 7F)
<0F [d1]>	Display stored text at the current cursor location. d1 = table entry number (00 to 7F)
10	Clear screen of both protected and unprotected characters and move the cursor to (0,0).
11	Terminate sequence of blinking characters. Ends a sequence of control characters that began with control code 13.
—continued—	

**Table 2-1**  
**Switch to workstation messages** (continued)

Value	Meaning/Description
12	Start_of_Call The first control code received at the beginning of a new call.
13	Start sequence. All the characters following this control code blink on the screen at the current cursor location until control code 11 is received.
14	Move cursor up one line.
15	Clear all unprotected data from cursor to the first protected character in a row. Cursor position is not changed.
<16 [d1]>	Erase stored text at current location. d1 = table entry number (00 to 7F)
<17 [d1] [d2] >	Set cursor address to column and row. d1 = column (00 to 3F) d2 = row (00 to 0F)
18	Not used.
<19 [d1]>	Erase stored text at predefined location. d1 = table entry number (00 to 7F)
1A	Clear all unprotected data on the screen and locate the cursor at the first unprotected position on the screen.
1B	Set cursor to (0,0). The switch often uses this command for timing by sending in several consecutive requests.
<1C [d1]>	Flash stored text at predefined cursor location. d1 = table entry number (00 to 7F)
<1D [d1]>	Display stored text at predefined cursor location. d1 = table entry number (00 to 7F)
1E	Not used.
1F	Not used.
—end—	

## Switch to workstation stored text definitions

Table 2-2 shows the stored text definitions with the following conventions:

- Row, column, and length values are decimal values.
- Text between quotes represents an ASCII string.
- The screen size is 16 by 64 characters decimal with home position at (0,0).
- In the text columns, blanks are represented by a “b” for clarity.

**Table 2-2**  
**Stored text definitions**

Entry	Text	Row	Column	Length	Protected
00	“RCAMA”	0	0	6	No
01	“CAMA”	0	0	6	No
02	“RCL”	0	0	6	No
03	“NFY”	0	0	6	No
04	“OVT”	0	0	6	No
05	“INW”	0	0	6	No
06	“181”	0	0	6	No
07	“555”	0	0	6	No
08	“ALM”	0	0	6	No
09	“131”	0	0	6	No
0A	“INTC”	0	0	6	No
0B	“SHIFT”	0	28	9	Yes
0C	“COIN”	0	8	8	No
0D	“COINbPO”	0	8	8	No
0E	“COINbPRE”	0	8	8	No
0F	“HOTEL”	0	8	8	No
10	“PER”	0	40	5	No
11	“STA”	0	40	5	No
12	“PD”	0	45	8	No
13	“COL”	0	45	8	No
—continued—					

**Table 2-2**  
**Stored text definitions** (continued)

Entry	Text	Row	Column	Length	Protected
14	"SPLbCLG"	0	45	8	No
15	"SPLbCLD"	0	45	8	No
16	"COIN"	0	53	6	No
17	"HOTEL"	0	53	6	No
18	"AUTObCOL"	0	40	13	No
19	"DIALbRATE"	2	33	13	No
1A	"NObAMA"	2	56	7	No
1B	"bbbAMA"	2	56	7	No
1C	"CLGb#b"	2	0	18	No
1D	"UCA"	4	21	3	No
1E	"PCB"	2	40	4	No
1F	"Tb&bC"	2	48	3	No
20	"HLD"	0	0	6	No
21	"CLDb#b"	4	0	24	No
22	"VCA"	4	21	3	No
23	"VFY"	4	21	3	No
24	"OVS"	4	21	3	No
25	"COINbCOL"	4	56	8	No
26	"COINbRET"	4	56	8	No
27	"RINGbBCK"	4	56	8	No
28	"RINGbFWD"	4	56	8	No
29	"RLSbBCK"	4	56	8	No
2A	"RLSbFWD"	4	56	8	No
2B	"ST"	14	35	3	Yes
2C	"SPLb#b"	6	0	30	No
2D	"CAbCALL"	6	47	7	No
2E	"STbTMG"	6	47	7	No
2F	"CAbTMG"	6	47	7	No
—continued—					

**Table 2-2**  
**Stored text definitions** (continued)

Entry	Text	Row	Column	Length	Protected
30	"CHGb"	8	0	22	No
31	"MIN"	8	18	4	No
32	"OCb"	8	25	8	No
33	"OPRb#b"	4	46	9	No
34	"POSbBUSY"	8	46	8	Yes
35	"CW"	8	58	6	Yes
36	"RSb"	10	0	7	No
37	"TRBLb"	10	18	7	No
38	"CAMAbSUSPENDEd"	10	33	14	No
39	"NFY"	10	9	6	No
3A	"HOT"	6	24	6	No
3B	"O"	0	0	6	No
3C	"bbbbbbBILL"	0	40	13	No
3D	"RMb#b"	12	0	12	No
3E	"NAMEb"	12	14	9	No
3F	"ASSTbPOSb"	10	38	12	Yes
40	"CHGbADJb"	14	0	23	No
41	"LOC"	4	21	3	No
42	"MON"	14	28	10	Yes
43	"CT"	14	32	2	Yes
44	"IPSb"	12	40	8	No
45	"AWTb"	13	40	8	No
46	"SYSb"	14	40	8	No
47	"CLG1"	10	54	4	Yes
48	"CLD1"	11	54	4	Yes
49	"CLG2"	10	60	4	Yes
4A	"CLD2"	11	60	4	Yes
4B	"HLD1"	13	54	4	Yes
—continued—					

**Table 2-2**  
**Stored text definitions** (continued)

Entry	Text	Row	Column	Length	Protected
4C	"ACS1"	13	54	4	Yes
4D	"LCK1"	13	54	4	Yes
4E	"HLD2"	13	60	4	Yes
4F	"ACS2"	13	60	4	Yes
50	"LCK2"	13	60	4	Yes
51	"NFY1"	12	54	4	Yes
52	"NFY2"	12	60	4	Yes
53	"TS"	0	0	6	No
54	"TSUB"	0	0	6	No
55	"APS"	0	0	6	No
56	"POSb"	12	0	7	No
57	"OPRb"	12	0	7	No
58	"Ob+"	0	0	6	No
59	"1+"	0	0	6	No
5A	"50"	0	0	6	No
5B	"55"	0	0	6	No
5C	"56"	0	0	6	No
5D	"SC"	4	25	3	No
5E	"CW"	10	0	6	No
5F	"25%bCT"	10	6	6	No
60	"ALLbT&CbPOS"	10	15	17	No
61	"OD"	10	27	5	No
62	"CD"	12	0	4	No
63	"NObSTbREG"	12	25	9	No
64	"TO"	0	22	3	No
65	"CD"	0	30	4	No
66	"MON"	0	38	3	No
67	"OCb"	2	0	7	No
—continued—					

**Table 2-2**  
**Stored text definitions** (continued)

Entry	Text	Row	Column	Length	Protected
68	"MBd"	2	11	8	No
69	"CTb"	2	22	6	No
6A	"ODb"	2	33	6	No
6B	"UCPb"	2	44	8	No
6C	"UCDb"	2	55	8	No
6D	"ASSTbPOSbAVL"	4	0	15	No
6E	"CALLSb"	4	18	9	No
6F	"OPRbPOSb"	5	0	8	No
70	"CLDb#b"	7	0	20	No
71	"STb"	7	0	20	No
72	"GENbCAL"	4	0	3	No
73	"DIRbCALL"	8	46	8	No
74	"NObASSTbPOS"	11	24	11	No
75	"XFRb"	0	19	7	No
76	"PRINTbT&C"	3	42	9	No
77	"T&C"	0	0	6	No
78	"58"	0	0	6	No
79	"59"	0	0	6	No
7A	Not used				
7B	Not used				
7C	Not used				
7D	Not used				
7E	Not used				
7F	Not used				
—end—					





# Protocol from the workstation to the UCS DMS-250 switch

This section describes the messages from the Operator Services workstation to the UCS DMS-250 switch. It includes keyname cross references.

## Overview of workstation message

Table 3-1 describes the messages sent from the workstation to the switch, ordered by hexadecimal message value. (For an abbreviated cross reference by keyname, see Table 3-2.)

## Messages listed by message value

The messages from the workstation to the switch are normally generated by operator keystrokes. The one exception is the automatic responses 11 and 12, generated by the switch sanity check, 0B.

**Table 3-1**  
**Workstation to switch messages by message value**

Code	Meaning	Description
09	MAKE BUSY	Toggles the “ready for calls” condition. This message may be used at any time (during or between calls) after initial sign on. The switch response is to display or erase stored message 34 (“POS BUSY”). The initial state following a successful login is “send no calls” with “POS BUSY” displayed.
0C	ASST POS	Accesses an assistance/incharge position. any available: <0C 2E> specific position: <0C [position] 2E> where: position = switch position number (ASCII digits 1–9999d)
—continued—		

**Table 3-1**  
**Workstation to switch messages by message value** (continued)

Code	Meaning	Description
0E	OGT #1	Requests the caller to be connected to a number in the switch's Outgoing Trunk table.
0F	OGT #2	Requests the caller to be connected to a number in the switch's Outgoing Trunk table.
11	SIGN ON	This code has two functions. When this message is sent unsolicited to the switch, it requests the workstation to be put into the switch's active queues. The message tells the switch the workstation is manned. The switch response is to display the stored message 34 ("POS BUSY") and to display the time. This message is also the expected sanity response to a 0B code received from the switch if the workstation is signed on.
12	SIGNED OFF	This is the expected sanity response to a 0B code received from the switch if the workstation is signed on.
<12 26>	SIGN OFF	Remove the workstation from switch active queues. The message tells the switch the workstation is unmanned. The switch response is to erase the stored message 34 ("POS BUSY").
16	OGT #3	Requests the caller to be connected to a number in the switch's Outgoing Trunk table.
18	OGT #4	Requests the caller to be connected to a number in the switch's Outgoing Trunk table.
1C	OGT #5	Requests the caller to be connected to a number in the switch's Outgoing Trunk table.
1D	XFR 1	Transfers a call to the XFER 1 queue. The switch response is to display stored message 75 ("XFR"). The transfer is not done until the POS REL code is sent to the switch. The transfer may be canceled before POS REL by sending the 1D code again. The switch response on a cancel is to erase stored message 75.
21	RLS BACK	Releases the operator from the calling party.
22	RING BACK	Recalls originating toll operator.
—continued—		

**Table 3-1**  
**Workstation to switch messages by message value** (continued)

Code	Meaning	Description
23	COIN COL	Used to collect coins from a coin phone.
24	TONE REPT	TONE REPT
25	CALL DET	Requests a switch to send all data about the call to the workstation. (Call detail information is normally sent automatically to the workstation at the start of a call.)
<26 08>	OPR	Identifies the operator to the switch. This is required before calls may be received. The switch response is to echo the operator number using stored message 33. The text is flashed on the screen if the number is not accepted. <26 08 [operator] 2E> where: operator = operator number (ASCII digits 1–9999d)
2A	NOTIFY	Requests the switch to reconnect a caller to the operator queue after a specified number of minutes have lapsed. <2A [minutes] 2E> where: minutes = number of minutes before notify (ASCII digits 1–99d)
2B	PER PD	Requests the switch to enter this charge class in the call detail record (CDR).
2D	PER SPL CLG	Requests the switch to enter this charge class in CDR.
2E	START	This code has two functions. It is used as an end of data indicator for all of the sequences requiring data (for example, FORWARD, OPR, ROOM). When used by itself, this code tells the switch to extend the called number onto the network.
3A	NAME	Enters characters into the name field of the CDR. The switch response is to echo characters using stored message 3E ("NAME"). <3A [name] 2E> where: name = 1 to 4 alphanumeric ASCII characters.
—continued—		

**Table 3-1**  
**Workstation to switch messages by message value** (continued)

Code	Meaning	Description
3B	CHG ADJ	Makes charge adjustments to the current call either in minutes or dollars. <3B + [trouble] + [type] + [amount] + 3E> where: trouble = 1- or 2-digit trouble code (ASCII digits) type = identify type of adjustment "M" for minutes, "C" for charge amount = adjustment amount in minutes or pennies (ASCII digits)
3C	HOLD	Puts the current loop (ACS1/ACS2) on hold. The switch response is a display of stored message 4B ("HLD1") or 4E ("HLD2").
3D	OVER SEAS	Used to enter international numbers. The switch response is to echo back number using stored message 21 ("CLD #") followed by a display of stored message 24 ("OVS"). <3D [ovs] 2E> where: ovs = overseas number up to 19d ASCII digits.
3E	POS REL	Requests the drop out of a call after all data has been entered.
5B	RATE STEP	Performs a manual rate step entry when the system cannot calculate. <5B [rate] 2E> where: rate = rate step up to 4 ASCII digits.
5C	TROUBLE	Causes a trouble report to be recorded on the switch. <5B [trbl] 2E> where: trbl= trouble code up to 4 ASCII digits.
5D	FORWARD	Used to enter called numbers. <5D [digits] 2E> where: digits = called number (10d ASCII digits).
5E	OVER COL	Used to apply credit to a coin phone call. <5E [amount] 2E> where: amount = credit amount in cents.
—continued—		

**Table 3-1**  
**Workstation to switch messages by message value** (continued)

Code	Meaning	Description
5F	BACK	Used to enter calling numbers. <5F [digits] 2E> where: digits = calling number (10d ASCII digits).
61	ACS1	Requests the Access 1 loop.
63	CANCEL CALL	Releases the operator from a call and cancels all entered data. The switch response is to display stored message 2D ("CA CALL"). The cancel will not be done until the POS REL code is sent to the switch. The CANCEL CALL may be canceled anytime before POS REL by sending in the 63 code again. The switch response is to erase stored message 2D.
64	CLD HOLD	Requests the called party be put on hold. This is a toggle code that is repeated to remove the called party from the hold. The status is indicated by a display or erase of stored message. The switch response is to display "CLDH1" at row 14d column 59d or "CLDH2" (Access 2) at row 14d column 54d.
65	COIN RET	Used to return coins to a coin phone customer.
67	AUTO COL	Requests the switch to enter this charge class in CDR.
68	STA SPL CLD	Requests the switch to enter this charge class in CDR.
69	COIN	Requests the switch to display the cost for the first 3 minutes of a call for coin phones. The STA PD or PER PD code must already have been sent. This code will also cause the switch to return the call to the operator queue at the end of 3 minutes.
6A	STA COL	Requests the switch to enter this charge class in CDR.
6B	STA PD	Requests the switch to enter this charge class in CDR.
6C	STA SPL CLG	Requests the switch to enter this charge class in CDR.
—continued—		

**Table 3-1**  
**Workstation to switch messages by message value** (continued)

Code	Meaning	Description
6D	PER COL	Requests the switch to enter this charge class in CDR.
6E	PER SPL CLD	Requests the switch to enter this charge class in CDR.
6F	HOTEL	Bill to room code.
70	XFR2	Transfer a call to the XFER 2 queue. The switch response is to display stored message 75 ("XFR"). The transfer will not be done until the POS REL code is sent to the switch. The transfer may be canceled anytime before POS REL by sending the 1D code again. The switch response is to erase stored message 75.
71	RLS FWD	Releases the operator from the called party.
72	CLG HOLD	Requests the calling party be put on hold. This is a toggle code. The status is indicated by a display or erase of stored message. The switch response is to display "CLGH1" at row 14d column 59d or "CLGH2" (Access 2) at row 14d column 54d.
73	ACS2	Requests the Access 2 loop.
78	CA TMG	Requests the billing timing on a call be canceled.
79	T & C	Requests that an operator be notified of time and charges when a caller hangs up.
7A	ST TMG	Requests that billing timing be started on a call.
7B	ROOM	Used to send room numbers on bill to room calls. <7B [digits] 2E> where: digits = room number up to 4 ASCII digits.
—continued—		

**Table 3-1**  
**Workstation to switch messages by message value** (continued)

Code	Meaning	Description
7D	SPECIAL	Used to enter special billing numbers. <7D [digits] 2E> where: digits = special number up to 19d ASCII digits.
7E	NO CONN (No Connection)	Permits a called or calling number to be sent to the switch, but prevents routing of the call. No switch response. <5D 7E [digits] 2E> where: digits = called or calling number.
—end—		

### Keyname cross reference

Table 3-2 provides an abbreviated cross reference by key name. (For message descriptions listed by message value, see Table 3-1.)

**Table 3-2**  
**Keyname cross reference**

Command	Code
ACS1	61
ACS2	73
ASST POS	0C
AUTO COL	67
BACK	5F
CALL DET	25
CANCEL CALL	63
CA TMG	78
CHG ADJ	3B
CLD HOLD	64
CLG HOLD	72
COIN	69
COIN COL	23
COIN RET	65
FORWARD	5D
HOLD	3C
HOTEL	6F
MAKE BUSY	09
NAME	3A
NO CONN	7E
NOTIFY	2A
OGT #1	0E
OGT #2	0F
OGT #3	16
—continued—	



**Table 3-2**  
**Keyname cross reference** (continued)

Command	Code
OGT #4	18
OGT #5	1C
OPR	<26 08>
OVER COL	5E
OVER SEAS	3D
PER COL	6D
PER PD	2B
PER SPL CLD	6E
PER SPL CLG	2D
POS REL	3E
RATE STEP	5B
RING BACK	22
RLS BACK	21
RLS FWD	71
ROOM	7B
SIGNED OFF	12
SIGN OFF	<12 26>
SIGN ON	11
SIGNED ON	11
SPECIAL	7D
START	2E
STA COL	6A
STA PD	6B
STA SPL CLD	68
STA SPL CLG	6C
ST TMG	7A
T & C	79
TONE REPT	24
—continued—	

**3-10** Protocol from the workstation to the UCS DMS-250 switch

---

**Table 3-2**  
**Keyname cross reference** (continued)

<b>Command</b>	<b>Code</b>
TROUBLE	5C
XFR1	1D
XFR2	70
—end—	

---

## Hints and examples

---

This section provides some helpful hints and examples of the data transmission protocol between the UCS DMS-250 switch and the Operator Services workstation.

### Considerations regarding data transmission

The following paragraphs provide some considerations and hints.

#### Delay of 0.2 seconds may be needed

The D-modem at the switch may drop data if it is received too fast. To send more than one command or command sequence to the switch, use a delay of 0.2 seconds after every other sequence.

For example, the following sequences, if sent from the workstation as a stream, should have a 0.2-second delay inserted between the KP\_FORWARD sequence and the START TIMING sequence.

```
<STA COL> + <KP_FORWARD + digits + START> + <START TIMING> +  
<POS RELEASE>
```

#### Methods to determine end of data

When collecting a data field from the switch, use a combination of three methods to determine the end of data. These methods are

- receiving a control code
- receiving maximum expected number of characters
- experiencing a timeout, waiting on characters (0.1 seconds is sufficient wait time)

#### Other considerations and cautions

Other considerations and cautions are as follows:

- An End\_of\_Call code may not be received by the switch if the new call comes off the call waiting queue. Be prepared to accept a Start\_of\_Call as an indication that the previous call is released.
- The switch often erases data it never wrote.

- Be prepared to receive the same data more than once.
- For other than Start\_of\_Call, do not depend on data fields being received in a particular sequence. A new software release load may have minor variations.

### Protocol examples

Several examples of protocol between the UCS DMS-250 switch and the workstation are graphically shown on the following pages. In all examples, the data flow direction (from the workstation to the switch or from the switch to the workstation) is indicated by arrows.

#### SIGN\_ON sequence

Figure 4-1 shows the SIGN\_ON sequence.

**Figure 4-1**  
**SIGN\_ON sequence**

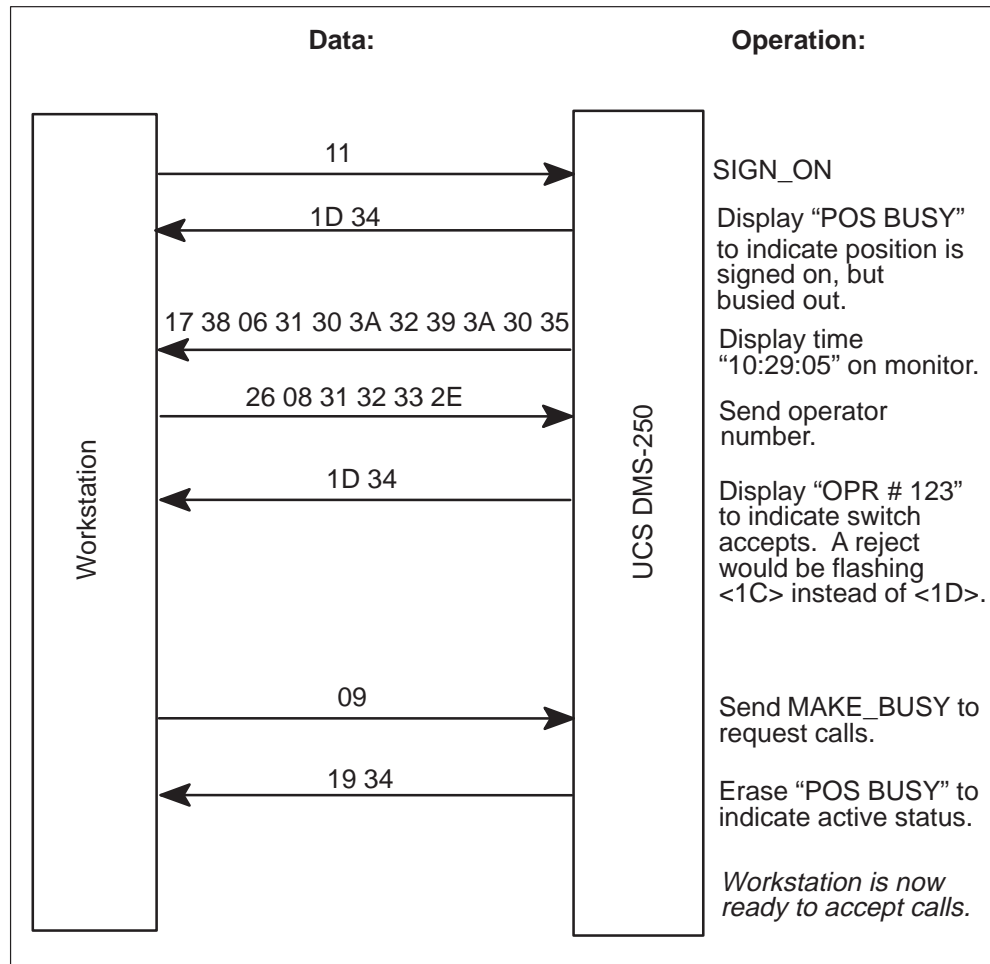

**SIGN\_OFF sequence**

Figure 4-2 shows the SIGN\_OFF sequence.

**Figure 4-2**  
**SIGN\_OFF sequence**

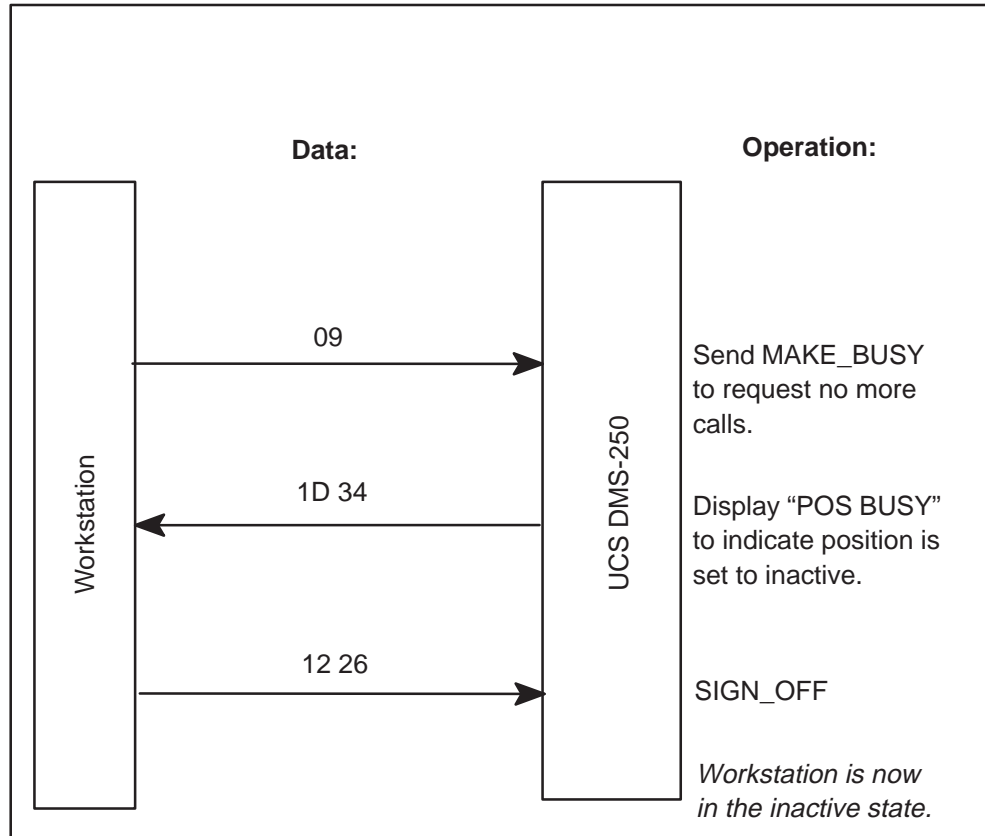

**0+ call arrival**

Figure 4-3 shows the 0+ call arrival.

**Figure 4-3**  
**0+ call arrival**

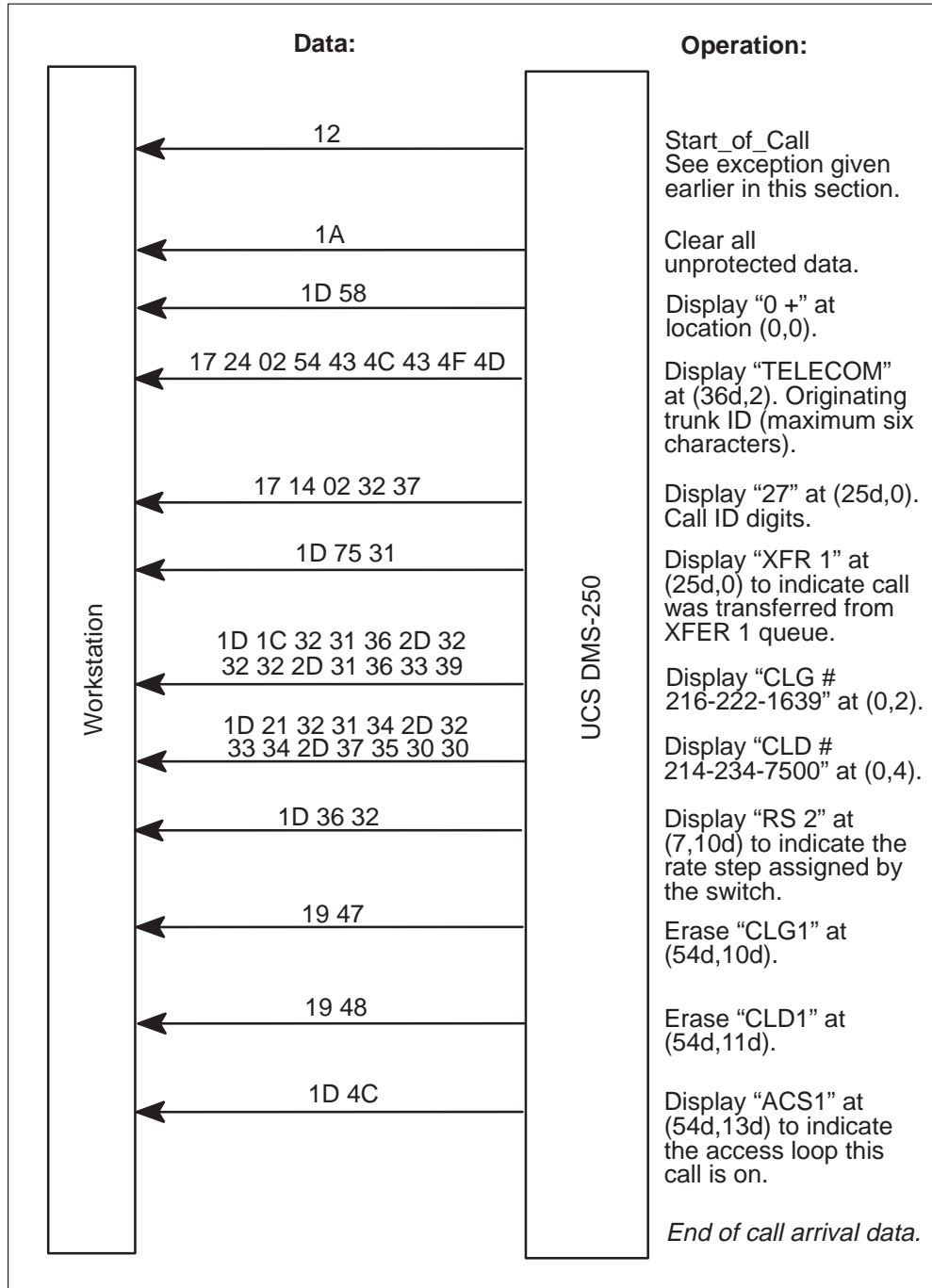

## Enter a calling card as special billing number

Figure 4-4 shows entering a calling card as a special billing number.

**Figure 4-4**  
Enter a calling card as special billing number

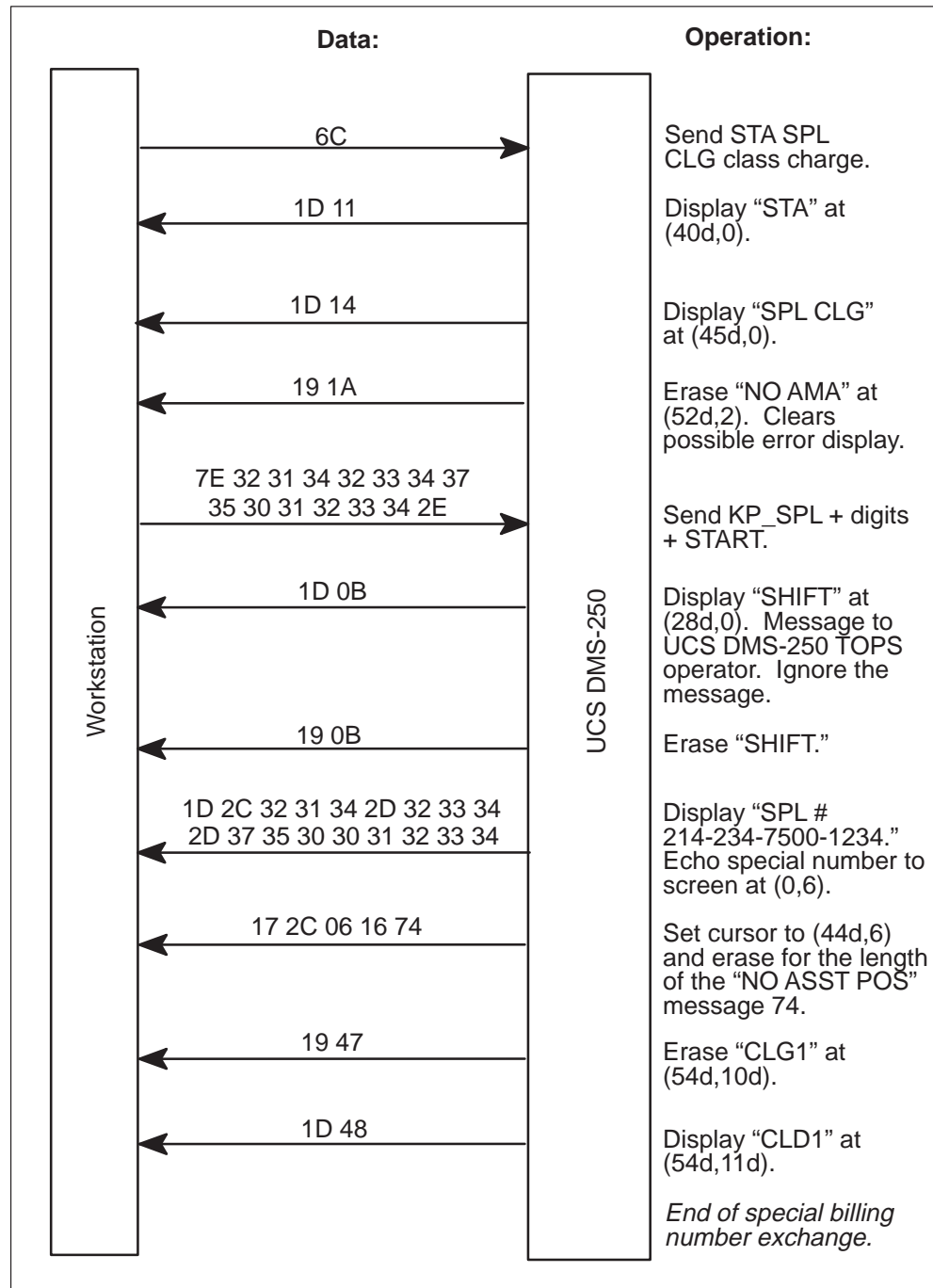

### Normal call release

Figure 4-5 shows the normal call release.

**Figure 4-5**  
Normal call release

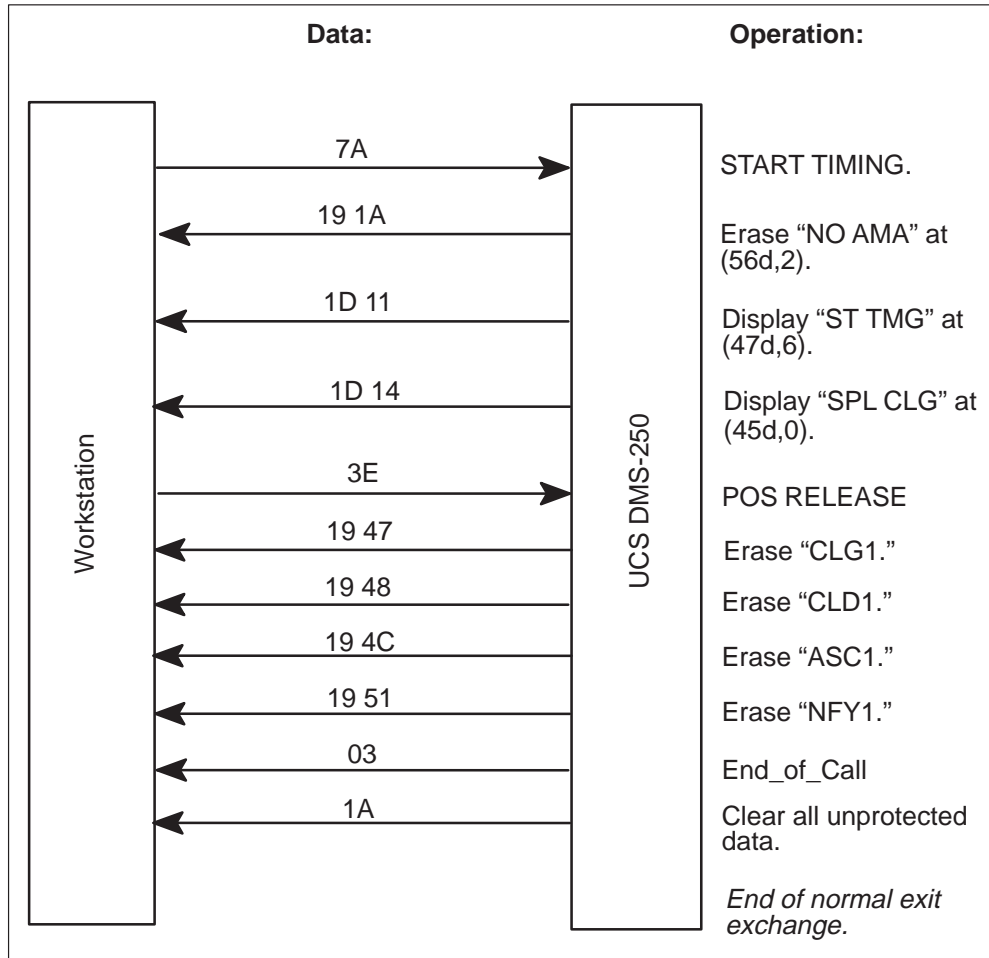



## Cancel call release

Figure 4-6 shows the cancel call release.

**Figure 4-6**  
Cancel call release

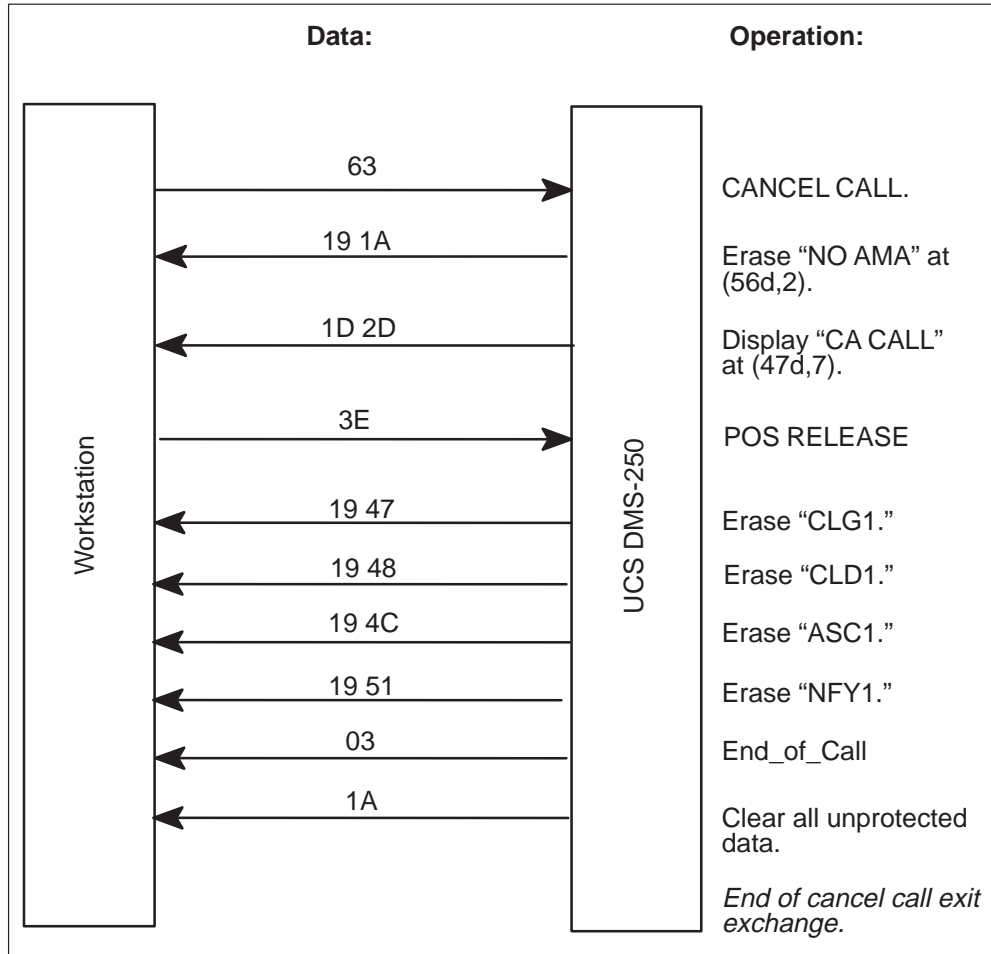



---

## List of terms

---

<b>ASCII</b>	American Standard Codes for Information Interchange
<b>CDR</b>	call detail record
<b>ID</b>	identification
<b>UCS</b>	Universal Carrier Software





Digital Switching Systems  
**UCS DMS-250**  
Operator Services Interface Specification

Product Documentation—Dept 3423  
Northern Telecom  
P.O. Box 13010  
RTP, NC 27709-3010  
1-877-662-5669, Option 4 + 1

© 1996, 1997 Northern Telecom  
All rights reserved

**NORTHERN TELECOM CONFIDENTIAL:** The information contained in this document is the property of Northern Telecom. Except as specifically authorized in writing by Northern Telecom, the holder of this document shall keep the information contained herein confidential and shall protect same in whole or in part from disclosure and dissemination to third parties and use same for evaluation, operation, and maintenance purposes only.

Information is subject to change without notice. Northern Telecom reserves the right to make changes in design or components as progress in engineering and manufacturing may warrant.

DMS, DMS-250, SuperNode, MAP, Nortel, NT, and TOPS are trademarks of Northern Telecom.

Publication number: 297-2631-101

Product release: UCS05

Document release: Standard 01.02

Date: February 1997

Printed in the United States of America

