

# Critical Release Notice

**Publication number: 297-8021-351**  
**Publication release: Standard 12.02**

## **Attention!**

\*\*\*\*\*

The North America DMS-100 Data Schema Reference Manual, 297-8021-351, will continue to be updated and provided in the North America - DMS NTP collection.

\*\*\*\*\*

The content of this customer NTP supports the SN09 (DMS) software release.

Bookmarks used in this NTP highlight the changes between the NA015 baseline and the SN08 (DMS) release. The bookmarks provided are color-coded to identify release-specific content changes. NTP volumes that do not contain bookmarks indicate that the NA015 baseline remains unchanged and is valid through the SN08 (DMS) release.

## **Bookmark Color Legend**

**Black:** Applies to content for the NA015 baseline that is valid through the current release.

**Red:** Applies to new or modified content for NA017 that is valid through the current release.

**Blue:** Applies to new or modified content for NA018 (SN05 DMS) that is valid through the current release.

**Green:** Applies to new or modified content for SN06 (DMS) that is valid through the current release.

**Purple :** Applies to new or modified content for SN07 (DMS) that is valid through the current release.

**Pink:** Applies to new or modified content for the SN08 (DMS) that is valid through the current release.

**Orange:** Applies to new or modified content for SN09 (DMS) that is valid through the current release.

## **Attention!**

*Adobe® Acrobat® Reader™ 5.0 or higher is required to view bookmarks in color.*

# Publication History

*Note: Refer to the NA015 baseline document for Publication History prior to the NA017 software release.*

## January 2006

Standard NTP release 12.02 for the SN09 (DMS) software release.

### Volume 1

Modified data schema – AMAOPTS (A00009252)

### Volume 4

Modified data schema – ESAPXLA (Q01228425-01)

### Volume 6

Modified data schema – IPNETWRK (Q01215905 and Q01227402)

### Volume 7

Modified data schema – LNSMTCE (Q00959081)

### Volume 9

New data schema – PATHSET (modified by Q01077097)

New data schema – SBSRMINV (Q01063949)

### Volume10

New data schema – SERVIRINV (Q01063949)

### Volume12

Deleted the term TBD, which occurred in two places in this volume.

## September 2005

Preliminary NTP release 12.01 for the SN09 (DMS) software release.

### Volume 1

Modified data schema – AMAOPTS (A00009252, A00009508); ANNMEMS, ANNPHLST (A00009013)

### Volume 8

Modified data schema – OAFUNDEF (A00009012)

### Volume 9

Modified data schema – SCAICOMS (A00009078)

**Volume 11**

Modified data schema – TOPSFTR (A00009012)

**Volume 12**

Modified data schema – TRKSGRP type ISDN (Q01112597)

Modified data schema – XPMIPMAP (A00009011)

**August 2005**

Standard NTP release 11.03 for the SN08 (DMS) software release.

**Volume 5**

Modified data schema – IBNFEAT feature SimRing

**Volume 6**

Modified data schema – KSETFEAT feature SimRing

**Volume 7**

Modified data schema – LTCINV

**Volume 11**

New data schema – TOPSMCDB

Modified data schema – TOPSTOPT

**June 2005**

Standard NTP release 11.02 for the SN08 (DMS) software release.

The following Data Schema content is updated for the SN08 (DMS) release. Content provided in this NTP is not superseded by content provided in the replacement NTP as indicated for the Preliminary release.

**Volume 3**

New data schema – CUSTSTN option CNDBO

**Volume 4**

Modified data schema – EADAS

**Volume 6**

New data schema – KSETINV

New data schema – LCMINV

**Volume 8**

New data schema – NSCDEFS

New data schema – NSCPMAP

## March 2005

Preliminary NTP release 11.01 for the SN08 (DMS) software release.

The following updated Data Schema content is provided in the Carrier VoIP Operational Configuration: Data Schema Reference NTP, NN10324-509. The content provided in NTP 297-8021-351 is superseded by the content provided in NTP NN10324-509.

ACDMISPL  
CGBLDADD  
CGBLDDGL  
CGBLDDIG  
CGBLDNI  
CGBLDPI  
CGPNBLDR  
CUSTSTN\_OPTION\_DBO  
EDAS  
IBNLINES  
ISERVOPT  
KSETINV  
TLDSIAMA\_OPTS  
TRKSGRP\_TYPE\_C7UP

The following new Data Schema content is provided in the Carrier VoIP Operational Configuration: Data Schema Reference NTP, NN10324-509. This content will not be provided in NTP 297-8021-351.

CGBLDSIN  
LOGTHROT  
NTPOLL

## October 2005

Standard release 10.04 for software release SN07 (DMS). Updates made in the North American Data Schema Reference Manual are shown below

### Volume 2

Table BEARNETS description added for CR Q01083765.

### Volume 3

Table DESDATA description added for CR Q01083765.

### Volume 4

Table DPTRKMEM was created as part of activity A59015739 in an earlier release. Documentation updated for CR Q01083781.

### **Volume 5**

Table IHEADRR description added for CR Q01083765.

### **Volume 8**

Table NET2NET description added for CR Q01083765

Table NETBRDGE description added for CR Q01083765

Table NETPATH description added for CR Q01083765

### **Volume 9**

Table PCEMENTT was created as part of activity A00007196 in an earlier release.  
Documentation updated for CR Q01077110.

Table PCEMFEID was created as part of activity A00007196 in an earlier release.  
Documentation updated for CR Q01077137.

Table PRSUDATA description added for CR Q01083765.

Table PVDNCHAN description modified for CR Q00806759/Q01207784

### **Volume 10**

Table SELDEFS and table SETDEFS descriptions added for CR Q01083765.

## **December 2004**

Standard release 10.03 for software release SN07 (DMS). Updates made in the North America Data Schema Reference Manual are shown below

### **Volume 9**

Table PECINV amended for CR Q00900178

Standard release 10.02 for software release SN07 (DMS). Updates made in the North America Data Schema Reference Manual are shown below

### **Volume 1**

AINPRESC (new), ACDENLOG, ACDGRP, ACDLOGIN, ANNS

### **Volume 2**

No changes

### **Volume 3**

CMIPADDR, CUSTSTN option AINDENY

### **Volume 4**

No changes

### **Volume 5**

IBNFEAT feature ACD, IBNFEAT feature SUPR

**Volume 6**

IPAPPL (new), KSETFEAT feature SUPR, KSETFEAT feature IPCLIENT, KSETLINE feature ACD

**Volume 7**

No changes

**Volume 8**

MULTITM (new), OAFUNDEF, OANODINV

**Volume 9**

PADDDATA, QMSMIS

**Volume 10**

No changes

**Volume 11**

TOPSFTR, TOPTDROP, TRIGINFO, TRIGITM, TRKAIN

**Volume 12**

No changes

**September 2004**

Preliminary release 10.01 for software release SN07 (DMS). Updates made in the North America Data Schema Reference Manual are shown below

**Volume 1**

ACDENLOG, ACDGRP, ACDLOGIN

**Volume 2**

AUTHCDE

**Volume 3**

CUSTN, CUSTN option VOWDN (new)

**Volume 4**

DIRPOOL2 (new), DIRPPool, DNROUTE, DNROUTE feature VOWDN (new)

**Volume 5**

IBNFEAT feature ECM, IBNXLA

**Volume 6**

ISUPTRK, KSETFEAT feature ECM

**Volume 7**

LIUINV, LTCINV, MNHSCARR, MSCIDMAP (new), MSCINMAP (new)

**Volume 8**

MUMRTAB

**Volume 9**

RESFEAT

**Volume 10**

TDBDAOPT, TMTMAP

**Volume 11**

TOLLTRKS, TOPSFTR, TOPSPARM, TOPSTLDN

**Volume 12**

TRKOPTS, VOWINV (new), XLABILL (new), XLACCLASS (new)

**March 2004**

Standard release 09.03 for software release SN06 (DMS). Updates made in the North America Data Schema Reference Manual are shown below.

**Volume 1**

DCA references changed / made obsolete

**Volume 2**

CARRMTC, C7UPTMR

**Volume 3**

DCA references changed / made obsolete

**Volume 4**

DNROUTE, DNROUTE feature DISA

**Volume 5-6**

No changes

**Volume 7**

LNPOPTS, LTDATA

**Volume 8**

OPTOPT

**Volume 9**

PADDATA, RDTINV

**Volume 10**

SUSHELF, SYNCLK, DCA references changed / made obsolete

**Volume 11-12**

No changes

**September 2003**

Standard release 09.02 for software release SN06 (DMS). Updates made in the North America Data Schema Reference Manual are shown below.

**Volume 1**

No changes

**Volume 2**

BCCODES

**Volume 3**

CSEDPMAP

**Volume 4**

DSLIMIT, FNPACONT.RTEREF

**Volume 5**

HNPACONT.RTEREF, IBNFEAT feature MWT, IBNLINES option MDN, IBNLINES option STN, IBNRTE selector CND, IBNRTE selector NOT, IBNXLA, IBNXLA selector FTR type LSPKP

**Volume 6**

ISDNPARM, ISERVOPT, KSETLINE

**Volume 7**

LENLINES, LTCINV, MNMGPIP

**Volume 8**

OFRT selector CND, OFRT selector NOT

**Volume 9**

No changes

**Volume 10**

STDPRTCT.STDPRT selector E911

**Volume 11**

TODHEAD, TONES, TRKGRP E911, TRKGRP type IT



## **Volume 12**

TRKOPTS, VFGDATA, VIRGRPS

### **June 2003**

Preliminary release 09.01 for software release SN06 (DMS). Updates made in the North America Data Schema Reference Manual are shown below.

## **Volume 1**

ACRTE, ALMSC, ALMSCGRP, ALMSD, ALDSDGRP, ANNAUDID (new), ANNMEMS, ANNPHLST (new)

## **Volume 2**

No changes

## **Volume 3**

CSEDPMAP (new), CUSTN option CFIND, DEFDATA

## **Volume 4**

FNPACONT

## **Volume 5**

HNPACONT, IBNFEAT feature CFIND, IBNLINES, IBNRTE selector CND, IBNRTE selector NOT

## **Volume 6**

ISERVOPT, KSETLINE

## **Volume 7**

LRGPINV (new), LTDATA, MNCKTPAK, MNIPPARM (new), MNNODE

## **Volume 8**

OFRT selector CND, OFRT selector NOT

## **Volume 9**

PADDDATA, REXSCHED

## **Volume 10**

SERVSINV, SPMECAN, SPMLDVAL (new), STDPRTCT.STDPRT selector E911

## **Volume 11**

TODHEAD, TONES, TRKGRP E911, TRKGRP type IT

## **Volume 12**

TRKMEM, TRKOPTS, TRKSGRP, VFGDATA, VIRTGRPS

**This page is intentionally blank.**

297-8021-351

DMS-100 Family

## **North American DMS-100**

Customer Data Schema Reference Manual Volume 10 of 12

Data Schema SCCPTMR-TMZONE

LET0015 and up Standard 05.02 May 2001

---



---

DMS-100 Family

## **North American DMS-100**

Customer Data Schema Reference Manual Volume 10 of 12

Data Schema SCCPTMR-TMZONE

---

Publication number: 297-8021-351

Product release: LET0015 and up

Document release: Standard 05.02

Date: May 2001

---

Copyright © 1996-2001 Nortel Networks,  
All Rights Reserved

Printed in the United States of America

**NORTEL NETWORKS CONFIDENTIAL:** The information contained herein is the property of Nortel Networks and is strictly confidential. Except as expressly authorized in writing by Nortel Networks, the holder shall keep all information contained herein confidential, shall disclose the information only to its employees with a need to know, and shall protect the information, in whole or in part, from disclosure and dissemination to third parties with the same degree of care it uses to protect its own confidential information, but with no less than reasonable care. Except as expressly authorized in writing by Nortel Networks, the holder is granted no rights to use the information contained herein.

Information is subject to change without notice. Nortel Networks reserves the right to make changes in design or components as progress in engineering and manufacturing may warrant. Changes or modification to the DMS-100 without the express consent of Nortel Networks may void its warranty and void the user's authority to operate the equipment.

Nortel Networks, the Nortel Networks logo, the Globemark, How the World Shares Ideas, Unified Networks, DMS, DMS-100, Helmsman, MAP, Meridian, Nortel, Northern Telecom, NT, SuperNode, and TOPS are trademarks of Nortel Networks.

---



---

# Contents

---

## Customer Data Schema Reference Manual Volume 10 of 12 Data Schema SCCPTMR-TMZONE

### NTP Summary Contents vii

---

<b>1</b>	<b>Data schema tables</b>	<b>1-1</b>
	SCCPTMR 1-2	
	SCGRP 1-5	
	SCHED 1-9	
	SCHEDF 1-15	
	SCHEDFI 1-17	
	SCHEDI 1-19	
	SCHNAME 1-20	
	SCHNUM 1-22	
	SCRNAMES 1-34	
	SCRNCLAS 1-35	
	SCRGRP 1-37	
	SCRNNAME 1-39	
	SCUFEAT 1-42	
	SDGRP 1-46	
	SDMBILL 1-49	
	SDMINV 1-52	
	SDSCUST 1-56	
	SDSINFO 1-58	
	SEILINKS 1-85	
	SERVICE 1-100	
	SERVICES 1-103	
	SERVNAME 1-111	
	SERVSCRN 1-113	
	SFWALARM 1-116	
	SHADOW 1-129	
	SIGACT 1-134	
	SILCNWM 1-143	
	SITE 1-147	
	SLELIST 1-150	
	SLLNKDEV 1-158	
	SLM 1-167	
	SLQGRP 1-169	

SLTANIID	1-172
SNIXAPPL	1-174
SNIXINFO	1-178
SNIXVOLS	1-182
SNPANAME	1-187
SNVLGRP	1-189
SOFTKEY	1-193
SORLIST	1-198
SPCCON	1-200
SPCTRKS	1-205
SPECCONN	1-211
SPID	1-239
SPIDDB	1-242
SPIDGRP	1-252
SPINFO	1-253
SPLANILN	1-267
SPLDNID	1-270
SPMCHAST	1-279
SPMECAN	1-282
SPMROUTE	1-287
SPMTIDMP	1-291
SPMTKMEM	1-293
SRASCRN	1-295
SRDBXFER	1-298
SRVRS	1-305
SSETNAME	1-307
SSPTKINF	1-309
SSRDEF	1-312
SSRFORM	1-316
STDPRTCT	1-319
STDPRTCT.AMAPRT	1-327
STDPRTCT.STDPRT	1-333
STDPRTCT.STDPRT selector D	1-374
STDPRTCT.STDPRT selector E911	1-375
STDPRTCT.STDPRT selector E911RTE	1-377
STDPRTCT.STDPRT selector EA	1-379
STDPRTCT.STDPRT selector ET	1-388
STDPRTCT.STDPRT selector F	1-391
STDPRTCT.STDPRT selector FGB	1-393
STDPRTCT.STDPRT selector FGDCL	1-396
STDPRTCT.STDPRT selector ID	1-398
STDPRTCT.STDPRT selector L	1-400
STDPRTCT.STDPRT selector N	1-402
STDPRTCT.STDPRT selector NSC	1-404
STDPRTCT.STDPRT selector P	1-407
STDPRTCT.STDPRT selector R	1-410
STDPRTCT.STDPRT selector S	1-412
STDPRTCT.STDPRT selector SFMT	1-414
STDPRTCT.STDPRT selector SSP	1-417
STDPRTCT.STDPRT selector T	1-419
STDPRTCT.STDPRT selector V	1-422



---

STDPRTCT.STDPRT selector Z	1-431
STIDX	1-440
STINV	1-442
STN	1-448
STPOOLS	1-455
STREAM	1-458
STSTONET-Canada only	1-460
SUBGRP	1-462
SUBPROT	1-469
SUPERTKG	1-472
SUR	1-473
SURI	1-477
SUSHELF	1-478
SVCDATA	1-486
SVCRATE	1-508
SVPRIGRP	1-510
SVRCKT	1-514
SYLNKINV	1-518
SYNCLK	1-520
SYNOGLNK	1-539
SYSDATA	1-545
TABLES	1-549
TABMON	1-550
TAPIDTAB	1-552
TARIFF	1-554
TAXES	1-556
TAXESI	1-561
TAXFIX	1-562
TAXMAP	1-565
TAXMAPI	1-568
TAXMAPS	1-569
TAXRATE	1-571
TCAPTRID	1-573
TCLG7DIG	1-577
TCLGVER	1-579
TDBCLASS	1-581
TDBDAOPT	1-588
TDBNORM	1-594
TDBSERV	1-597
TDCDEF	1-600
TDCHLDY	1-603
TDCSCHED	1-605
TEAMACD	1-607
TERMDEV	1-608
TERMRC	1-617
TERMRCI	1-619
TERMSCRN	1-620
TEXTLOG	1-622
TEXTPHRS	1-626
TFANINT	1-630
TFSSCRN	1-635

TIESCDIG	1-637
TIMEODAY	1-639
TIMESPEC	1-647
TIMEZONE	1-667
TKCVDATA	1-669
TKFXPT	1-684
TKMTRNAM	1-689
TKSIGSYS	1-690
TKTONODE	1-696
TLCLORIG	1-699
TLCLSCRN	1-701
TLCLZONE	1-703
TMINV	1-705
TMSOCDL	1-723
TMSPSDEV	1-726
TMSPVC	1-729
TMTCNTL	1-733
TMTCNTL.TREAT	1-734
TMTMAP	1-830
TMZONE	1-874

---

# NTP Summary Contents

---

**Customer Data Schema Reference Manual Volume 1 of 12**

Data Schema AABSFILT-ATTSCHEM

**Customer Data Schema Reference Manual Volume 2 of 12**

Data Schema AUDALARM-CCVPARMS

**Customer Data Schema Reference Manual Volume 3 of 12**

Data Schema CDACCESS-DFINV

**Customer Data Schema Reference Manual Volume 4 of 12**

Data Schema DGCODE-FTRGMEMMS

**Customer Data Schema Reference Manual Volume 5 of 12**

Data Schema FTRGOPTS-INWTMAP

**Customer Data Schema Reference Manual Volume 6 of 12**

Data Schema IOC-LENFEAT feature WML

**Customer Data Schema Reference Manual Volume 7 of 12**

Data Schema LENLINES-MSRTAB

**Customer Data Schema Reference Manual Volume 8 of 12**

Data Schema MTAHORIZ-OPTOPT

**Customer Data Schema Reference Manual Volume 9 of 12**

Data Schema OQCQPROF-SCALLTAB

**Customer Data Schema Reference Manual Volume 10 of 12**

Data Schema SCCPTMR-TMZONE

**Customer Data Schema Reference Manual Volume 11 of 11**

Data Schema TODHEAD-TRKGRP type NU

**Customer Data Schema Reference Manual Volume 12 of 12**

Data Schema TRKGRP type OC-ZONEORDR

---

# 1 Data schema tables

---

The following pages contain the data schema tables.

## SCCPTMR

---

### Table name

SCCP Class-2 timers

### Functional description

This table allows operating company personnel to define class-2 protocol timer values for signaling connection control parts (SCCP). Adjustment of the timer values allows operating company personnel to adjust traffic flow.

This table is normally empty. When the table is empty, the CCS7 link interface unit (LIU7) uses default values for the class-2 protocol timers.

*Note:* Signaling transfer points (STP) do not support this table.

### Datafill sequence and meaning

You do not need to enter data in other tables before you enter data in table SCCPTMR.

### Table size

1 tuple

### Datafill

Datafill for table SCCPTMR appears in the following table.

#### Field descriptions (Sheet 1 of 2)

Field	Subfield or refinement	Entry	Explanation and action
INDEX		0	<i>Tuple index number.</i> Enter 0. This entry is the only correct entry.
TCONNECT		10 to 360	<i>Connection establishment timer.</i> Enter a timeout value in seconds for the connection establishment timer. If the timer expires, the system releases the connection. The default value is 60.

**SCCPTMR** (continued)

## Field descriptions (Sheet 2 of 2)

Field	Subfield or refinement	Entry	Explanation and action
TCNNREL		10 to 20	<i>Connection release timer.</i> Enter a timeout value in seconds for the connection release timer. The timer can expire before the local SCCP connection oriented control (SCOC) receives a connection release confirmation from the remote SCOC. If this event, the local SCOC sends another connection release request. Each time the timer expires, the SCOC sends another connection release request. This action continues until the release interval timer expires. The default value is 10 (10 s).
TINTERVL		60 to 180	<i>Release interval timer.</i> Enter a timeout value in seconds for the release interval timer. The interval timer starts when an SCOC sends a connection release request. If the timer expires, the system records the connection as released. The default value is 60 (60 s).
TIASEND		120 to 600	<i>Inactivity send timer.</i> Enter a timeout value in seconds for the inactivity send timer. This timer resets each time a local application sends a message. The timer can expire before the local application sends another message. If this event, the local SCOC sends an inactivity test message to the far end. The default value is 120 (120 s).  <b>Note:</b> The value in field TIASEND must be less than the value in field TIARCV.
TIARCV		300 to 1320	<i>Inactivity receive timer.</i> Enter a timeout value in seconds for the inactivity receive timer. This timer resets each time an SCOC receives a message. If the timer expires before the SCOC receives a message, the system releases the connection. The default value is 300 (300 s).  <b>Note:</b> The value in field TIARCV must exceed the value in field TIASEND

## SCCPTMR (end)

---

### Datavfill example

Sample datavfill for table SCCPTMR appears in the following example.

### MAP example for table SCCPTMR

INDEX	TCONNECT TIASEND	TCONNREL TIARCV	TINTERVL
0	10 120	20 300	60

### Table history

#### BCS36

Table SCCPTMR was created in BCS36.

### Additional information

#### Error messages

An attempt to enter data in table SCCPTMR for STPs produces the following error message.

Table SCCPTMR is not supported on an STP.



---

**SCGRP**

---

**Table name**

Scan Group Table

**Functional description**

Table SCGRP contains the product engineering code (PEC) and the location at the host or remote switch units for specified scan groups. These scan groups are reserved for use as scan points for line features.

The maximum number of scan groups assigned to line features is 512 (0 to 511). Alarm and network management scan groups cannot have the locations of the scan groups assigned for line features.

See table ALMSCGRP and table NWMSC for information on alarm and network management scan groups.

A miscellaneous scan card for each NT0X10AA PEC provides 14 single-lead scan points. The card subdivides in two scan groups. Each scan group contains seven scan points (0 to 6). Each scan group is assigned to a trunk module circuit number. A maintenance trunk module (MTM) can contain a maximum number of 18 scan cards.

The seven scan points in the scan group are available for assignment to the following parts:

- Integrated Business Network (IBN)
- P-phones or normal lines with line features Random Make Busy (RMB) or Stop Hunt (SHU) that require different scan points

You can assign scan points to the following:

- normal lines in table LENFEAT
- IBN lines in table IBNFEAT
- P-phones in table KSETFEAT

You must assign lines in the host switching unit to scan points that belong to specified scan groups. These scan groups are at the host switching unit.

You must assign lines at a remote location to scan points that belong to scan groups located at the remote location.

**SCGRP** (continued)**Datafill sequence and meaning**

Enter data in the following tables before you enter data in table SCGRP:

- DATASIZE
- TMINV

**Table size**

Before CSP02, the value of field SIZE allocates memory for this table. Field SIZE appears in table DATASIZE and has the value of field DATSKEY equal to SCGRP

For CSP02 and later versions, a restart is not a requirement to increase the table size. Table DATASIZE does not require tuple SCGRP. Versions before CSP02 require the user to extend the length of the table. The user must increase the size in table DATASIZE and perform a cold restart.

*Note:* If the NORESTARTSWACT utility is available on your switch, the activation of data changes does not interrupt service. Refer to the *NORESTARTSWACT/MTCWACT User's Guide*.

**Datafill**

Datafill for table SCGRP appears in the following table.

**Field descriptions (Sheet 1 of 2)**

Field	Subfield or refinement	Entry	Explanation and action
SCGRPNO		0 to 511	<i>Scan group.</i> Enter the scan group number.
TMTYPE		MTM, RMM, or RSM	<i>Trunk module type.</i> Enter the type of trunk module that contains the miscellaneous scan card. This trunk type can be a maintenance trunk module (MTM), remote maintenance module (RMM), or remote service module (RSM).  Any entry outside this range is not correct.

**SCGRP** (continued)**Field descriptions (Sheet 2 of 2)**

Field	Subfield or refinement	Entry	Explanation and action
TMNO		0 to 255	<i>Trunk module number.</i> Enter the number assigned to the maintenance trunk module, remote maintenance module, or remote service module that contains the miscellaneous scan card.  Any entry outside this range is not correct.
TMCKTNO		0 to 23	<i>Trunk module circuit number.</i> Enter the trunk module circuit number on the maintenance trunk module, remote maintenance module, or remote service module that has a scan group assigned.  Any entry outside this range is not correct.
CARDCODE		0X10AA	<i>Product engineering code (PEC).</i> Enter the PEC of the scan card 0X10AA. Any entry outside this range is not correct.

**Datafill example**

Datafill for table SCGRP appears in the following example.

In this example, scan groups 0 and 1 are at the host switching unit. Groups 2 and 3 are at the Merivale (MERV) remote location.

To assign scan points in the scan group, see examples of tables LENFEAT, KSETFEAT and IBNFEAT.

**MAP example for table SCGRP**

SCGRPNO	TMTYPE	TMNO	TMCKTNO	CARDCODE
0	MTM	1	14	0X10AA
1	MTM	1	15	0X10AA
2	RSM	0	12	0X10AA
3	RSM	0	13	0X10AA

**SCGRP** (end)

---

**Table history**

**CSP02**

A sentence to indicate that a restart is not a requirement to increase table size was added. Table DATASIZE does not require an entry for table SCGRP.

**BCS36**

A reference to the NORESTARTSWACT utility was added.

---

**SCHED**

---

**Table name**

TOPS Rate Schedule Table

**Functional description**

Table SCHED is used by the DMS Automatic Rating System to determine the following information for a specified rate schedule:

- The range of rate steps associated with the rate schedule. The rate steps associated with this rate schedule in tables CLDNPA, CLDNPAEX, MILES, PTP, LCLRS, SRV, or OVSRS must fall within this range.
- The termination type to determine which table or tables can be involved in the calculation of the rate step as follows:
  - domestic termination type: tables CLDNPA, CLDNPAEX, MILES, PTP
  - overseas termination type: table OVSRS
  - local termination type: table LCLRS
  - service termination type: table SERVSCRN
- The schedule type to determine which factors are to be used in the calculation of charges by generating table CHGTAB, which together with tables SCHNAME and RATESTEP provides a key into table CHARGE as detailed on the following pages.
- The coin recall periods:
  - There are two fields, CIRP (coin initial recall period) and CRP (coin recall period), in table SCHED to allow the telephone company to specify coin recall periods for each schedule.
  - Field CIRP enables the phone company to specify an initial coin recall period on coin calls. This period is independent of field INP in table CHARGE. Field INP is used for rating purposes only. For example, field INP in table CHARGE is set to 1 and field CIRP in table SCHED is set to 2. In this case, if the customer is recalled to the Traffic Operator Position System (TOPS) operator after the initial period of two minutes, the customer is already on the first minute of overtime charge since field INP is set to 1.
  - Field CRP enables the phone company to specify subsequent coin recall periods.

## **SCHED** (continued)

---

### **Schedule type description**

The schedule type is used to define which factors are to be used in the calculation of charges by generating table CHGTAB, which together with tables SCHNAME and RATESTEP, provides a key into table CHARGE.

Table CHGTAB has the format XXYYZZ. See table CHARGE for further information.

### **Overseas Operator Center (OOC):**

Table SCHED provides for the specified rate schedule and range of rate steps, the termination type (DOM [domestic], OVS [overseas], or LOCAL [local]), schedule type (STD [standard], MLT [multitier], CCT [call type], SCT [station class]), and coin initial and recall period information. The rate schedule is the grouping of common set of rating characteristics that apply from the originating point to the terminating point, and rate step is the arbitrary value assigned to each overseas destination.

When the tuples are added to this table, internal table RSTRANS is updated. Table RSTRANS a schedule number mapping for each rate step value, which is subsequently used by the charge calculator.

Table SCHED control is modified to allow only the overseas termination type (OVS). This is to allow for charges based on type of call (station [STN] or person [PER]) and discount type (ND [no discount], QUOTED [quoted discount], D1 to D6 [discount values 1 to 6]).

### **Mass Table Control**

Feature V0178 (TOPS Mass Table Control) permits data changes in table SCHED to be mass-table-controlled. In other words, the feature permits the simultaneous activation of data changes in the table by entering the data changes for the table into table SCHEDI, and then, when all the required changes are entered, swap the contents of table SCHED with table SCHEDI.

For further information on feature V0178, refer to table CHARGEI.

### **Datafill sequence and implications**

Table SCHNUM must be datafilled before table SCHED.

### **Table size**

0 to 999 tuples

**SCHED** (continued)**Datafill**

The following table lists datafill for table SCHED.

**Field descriptions (Sheet 1 of 3)**

<b>Field</b>	<b>Subfield or refinement</b>	<b>Entry</b>	<b>Explanation and action</b>
SCHNAME		alphanumeric (1 to 17 characters)	Schedule name key. Enter the name of the rate schedule as previously defined in table SCHNUM.  The entry in this field cannot be the schedule name associated with schedule number 0 (zero).
LRS		0 to 998	Lowest rate step. Enter the lowest rate step for that schedule.
HRS		0 to 998	Highest rate step. Enter the highest rate step for that schedule.  The entry in field HRS must be equal to the entry in field LRS plus a number between 0 to 63.  The rate step range (fields LRS and HRS) for a schedule cannot overlap with range of another schedule.  If tables CLDNA, MILES, PTP, LCLRS, or OVSRS are used for the automatic determination of the schedule name and rate step, the rate step must be within the range specified in table SCHED for the schedule name.

**SCHED** (continued)

**Field descriptions (Sheet 2 of 3)**

Field	Subfield or refinement	Entry	Explanation and action
TERMTYPE		DOM, LOC, OVS, or SRV	<p>Termination type. Enter the termination type for this schedule name as follows:</p> <p>DOM (domestic): must match the translation derived if translation system is national (field TRANSYS set to NA) and Type of call is direct dial or operator assisted (field TYPSCALL set to DD or OA).</p> <p>LOC (local): must match the translation derived if translation system is national (field TRANSYS set to NA) and type of call is no prefix (field CALLTYPE set to NP).</p> <p>OVS (overseas): must match the translation derived if translation system is international (field TRANSYS set to IN).</p> <p>SRV (service): a service called number has a type of SRV if it is datafilled as SRV in table SERVSCRN.</p> <p>Overseas Operator Center (OOC) is restricted to OVS.</p>
SCHTYPE		CTT, MLT, SCT, or STD	<p>Schedule type . Enter the schedule type. For more information, refer to table CHARGE.</p> <p>Enter CTT if call-type tier rating is required. Rates differentiated by station (STA) or person (PER), and call type is DD (direct dial), OA (operator-assisted), or OH (operator-handled).</p> <p>Enter MLT if multitier rating is required. Rates differentiated by STA or PER, call type is DD, OA, or OH, and station class is coin or non-coin.</p> <p>Enter SCT if station-class tier rating is required. Rates differentiated by STA or PER, and station class is coin or non-coin.</p> <p>Enter STD if standard routing required. Rates differentiated by call being person to person (PER) or station to station (STA).</p> <p>OOC is restricted to STD.</p>



**SCHED** (continued)

**Field descriptions (Sheet 3 of 3)**

Field	Subfield or refinement	Entry	Explanation and action
CIRP		0 to 15	<p>Coin initial recall period. Enter the initial coin recall period in minutes after which the customer is reconnected to a Traffic Operator Position System (TOPS) operator.</p> <p>An entry of 0 (zero) means that the customer is not recalled to the operator.</p> <p>The entry in this field must be equal to or greater than the entry in field INP in table CHARGE.</p>
CRP		0 to 15	<p>Coin recall period . Enter the coin recall period, in minutes, that applies following the initial coin recall period specified in field CIRP above.</p> <p>As a precaution against loss of revenue on paid calls, the customer is reconnected to a TOPS operator after the time interval specified in this column.</p> <p>The charge for the specified period is automatically calculated and displayed to the operator.</p> <p>An entry of 0 (zero) means that the customer is not recalled to the operator.</p> <p>If the value in field CIRP is 0 (zero), the value in field must also be 0 (zero).</p>

**Datafill example**

The following examples show datafill for table SCHED.

The first example shows datafill for the North American TOPS.

**MAP display example for table SCHED**

SCHNAME	LRS	HRS	TERMTYPE	SCHTYPE	CIRP	CRP
ONTQUE	1	17	DOM	STD	3	10

**SCHED** (end)

---

The second example shows datafill for the Caribbean Expansion Plan (CEP) International TOPS (ITOPS).

**MAP display example for table SCHED**

SCHNAME	LRS	HRS	TERMTYPE	SCHTYPE	CIRP	CRP
CANADA	36	37	DOM	STD	3	10
LOCAL	350	350	LOC	MLT	0	0

**SCHEDDEF****Table name**

ITOPS Rating Rate Step Calculator Schedule Table

**Functional description**

Table SCHEDDEF associates a schedule name and ratestep range with a termination type. The available termination types are LOCAL, FOREIGN, NATIONAL, and SERVICE.

This association is used for preparing the datafill of tables RSLOC, RSNAT, RSFOR, and RSSERV to ensure that only combinations of schedule names and ratesteps that are associated in table SCHEDDEF with termination types of LOCAL, FOREIGN, NATIONAL, or SERVICE are respectively datafilled in these tables.

Table SCHEDDEF is the active table in the pairing of tables SCHEDDEF and SCHEDDEFI. The active table is used by the software for call processing, therefore, changes cannot be made to the active data while it is in use. The inactive table is used to allow changes to the service rating table by the operating company during normal working hours. The active table is compared with the data in the inactive table and is automatically updated during low traffic periods.

For related information, see table ATRIMOD.

**Datafill sequence and implications**

There is no requirement to datafill other tables prior to table SCHEDDEF.

**Table size**

0 to 64 tuples

**Datafill**

The following table lists datafill for table SCHEDDEF.

**Field descriptions (Sheet 1 of 2)**

Field	Subfield or refinement	Entry	Explanation and action
SCHNAME		alphanumeric (1 to 16 characters)	Schedule name. Enter a schedule name that is datafilled in table SCHNAME.
LRS		0 to 999	Lowest rate step. Enter the lowest rate step for this schedule.

**SCHEDDEF** (end)

**Field descriptions (Sheet 2 of 2)**

Field	Subfield or refinement	Entry	Explanation and action
HRS		0 to 999	Highest rate step. Enter the highest rate step for this schedule. HRS must = LRS + (0 to 63). Rate step range (LRS to HRS) for a schedule cannot overlap with the range of another schedule.
TERMTYPE		FOREIGN, LOCAL, NATIONAL, or SERVICE	Termination type. Enter one of the following termination types: NATIONAL for national_toll; FOREIGN for foreign; LOCAL for national_local; or SERVICE for custom service.

**Datafill example**

The following example shows sample datafill for table SCHEDDEF.

**MAP display example for table SCHEDDEF**

SCHNAME	LRS	HRS	TERMTYPE
SCHED1	300	320	NATIONAL

**Table history**  
**BCS35**

Entry SERVICE was added to field TERMTYPE.

**SCHEDFEI****Table name**

ITOPS Inactive Rating Ratestep Calculator Schedule Table

**Functional description**

Table SCHEDFEI associates a schedule name and ratestep range with a termination type. The available termination types are LOCAL, FOREIGN, NATIONAL, and SERVICE.

The association is used for preparing the datafill of tables RSLOC, RSNAT, RSFOR, and RSSERV to ensure that only combinations of schedule names and ratesteps that are associated in table SCHEDFEI with termination types of LOCAL, FOREIGN, NATIONAL, or SERVICE are, respectively, datafilled in these tables.

Table SCHEDFEI is the inactive table in the pairing of tables SCHEDFE and SCHEDFEI. The active table is used by the software for call processing, therefore, changes cannot be made to the active data while it is in use. The inactive table is used to allow changes to the service rating table by the operating company during normal working hours. The active table is compared with the data in the inactive table and is automatically updated during low traffic periods.

For related information, refer to table ATRIMOD.

**Datafill sequence and implications**

There is no requirement to datafill other tables prior to table SCHEDFEI.

**Table size**

0 to 64 tuples

**Datafill**

The following table lists datafill for table SCHEDFEI.

**Field descriptions (Sheet 1 of 2)**

Field	Subfield or refinement	Entry	Explanation and action
SCHNAME		alphanumeric (1 to 16 characters)	Schedule name. Enter a schedule name that is datafilled in table SCHNAME.
LRS		0 to 999	Lowest rate step. Enter the lowest rate step for this schedule.

**SCHEDEFI** (end)

**Field descriptions (Sheet 2 of 2)**

Field	Subfield or refinement	Entry	Explanation and action
HRS		0 to 999	Highest rate step. Enter the highest rate step for this schedule. HRS must = LRS + (0 to 63). Ratestep range (LRS to HRS) for a schedule cannot overlap with the range of another schedule.
TERMTYPE		FOREIGN, LOCAL, NATIONAL, or SERVICE	Termination type. Enter one of the following termination types: NATIONAL for national toll; FOREIGN for foreign; LOCAL for national local; or SERVICE for custom service.

**Datafill example**

The following example shows sample datafill for table SCHEDEFI.

**MAP display example for table SCHEDEFI**

SCHNAME	LRS	HRS	TERMTYPE
SCHED1	300	320	NATIONAL

**Table history**

**BCS35**

Table SCHEDEFI introduced

---

**SCHEDI**

---

**Table name**

TOPS Rate Schedule Inactive Table

**Functional description**

Feature V0178 (TOPS Mass Table Control) permits data changes in table SCHED to be mass-table-controlled. In other words, the feature permits the simultaneous activation of data changes in the table by entering the data changes for the table into table SCHEDI, and then, when all the required changes are entered, swap the contents of table SCHED with table SCHEDI.

For further information on feature V0178, refer to table CHARGEI.

Refer to table SCHED.

**Datafill sequence and implications**

Refer to table SCHED.

**Table size**

Refer to table SCHED.

**Datafill**

Refer to table SCHED.

**Datafill example**

Refer to table SCHED.

## SCHNAME

---

### Table name

ITOPS Rating Rate Step Calculator Schedule Table

### Functional description

Table SCHNAME defines the valid schedule names used by the system.

For related information, refer to Table ATRIMOD.

### Datafill sequence and implications

The following tables must be datafilled after table SCHNAME.

- ATRIMOD
- CHGATRIB
- CHGHEAD
- HOLITRMT
- MODMAP
- RATEMOD
- RSFOR
- RSLOC
- RSNAT
- SCHEDEF
- TAXMAPS

There is no requirement to datafill other tables prior to table SCHNAME.

### Table size

0 to 64 tuples

### Datafill

The following table lists datafill for table SCHNAME.

### Field descriptions

Field	Subfield or refinement	Entry	Explanation and action
SCHNAME		1 to 16 alphanumeric characters	Schedule name. Enter a schedule name.



---

**SCHNAME** (end)

---

**Datafill example**

The following example shows sample datafill for table SCHNAME.

**MAP display example for table SCHNAME**

SCHNAME
_____
SCHED1

## SCHNUM

---

### Table name

TOPS List of Rate Schedule Names Table

### Functional description

Table SCHNUM is used to associate a rate schedule name with a number. This association is used in domestic and overseas rating and charging. Each rate schedule must be entered in table SCHNUM before it can be referenced elsewhere.

### Overseas Operator Center (OOC)

Table SCHNUM assigns a numerical value to the schedule name that is subsequently used by call processing to reference that schedule.

*Note:* Each schedule name has a different numerical value assigned.

### Datafill sequence and implications

There is no requirement to datafill other tables prior to table SCHNUM.

*Note:* Table editor command DELETE is not allowed for table SCHNUM.

### Table size

0 to 64 tuples

**SCHNUM** (continued)**Datafill**

The following table lists datafill for table SCHNUM.

**Field descriptions**

Field	Subfield or refinement	Entry	Explanation and action
VALUE		0 to 32767	<p>Schedule number. Enter the number associated with the schedule name. Numbers can be chosen arbitrarily with the restriction that no two schedule names can be associated with the same number and no two numbers can be associated with the same schedule name.</p> <p>A maximum of 63 schedule names are allowed, ranging from 1 to 63.</p> <p>Schedule 0 (zero) is reserved for internal use by DMS software.</p> <p>Entries outside the indicated range are invalid.</p>
SYMBOL		alphanumeric (1 to 32 characters)	Schedule name. Enter the schedule name associated with the above schedule number.

**Datafill example**

The following examples show sample datafill for table SCHNUM.

The first example shows datafill for the North American Traffic Operator Position System (TOPS).

**MAP display example for table SCHNUM**

VALUE	SYMBOL
1	ONTQUE

The second example shows datafill for the Caribbean expansion plan (CEP) international TOPS (ITOPS).

## SCHNUM (continued)

---

### MAP display example for table SCHNUM

VALUE	SYMBOL
2	STKITTS465

### Supplementary information

This section provides information on the TOPS rating test program (RATE).

### TOPS rating test program (RATE)

The RATE program is used by the operating company to verify TOPS rating system datafill.

The RATE program works only on a DMS switch with TOPS software.

With this program the operating company can:

- type in relevant details of a test call from the command interpreter (CI) level of a MAP terminal
- request rate step, charge calculation, or both for a test call, with results appearing on the MAP terminal

The test program is completely independent of TOPS call processing and TOPS positions. It uses data from the TOPS rating system data tables. Ensure that correct entries and values are in these tables before using this program.

The program is invoked by typing RATE on the MAP terminal. Relevant details of the test call are then entered.

A test call can be set up by using a list of available subcommands. After the setup, the program performs the calculations and displays the results on the MAP terminal.

The syntax of the subcommands is as follows:

```
subcommand name <subcommand entry>
```

For example: CLG 6135994231 indicates to the RATE program that the calling number of the test call is 6135994231.

If the subcommand entry is left blank, the previous setting is displayed as current.

**SCHNUM** (continued)

All data entries associated with this program remain unchanged until they are overwritten by subsequent entries.

**Note:** These data entries are associated with a test call and not entries associated with the TOPS rating system data tables. The rating system data tables (for example, CLDNPA, CLGTRF, SCHED, and so on) have to contain valid data before this program can be successfully run.

**Subcommands for RATE program (Sheet 1 of 5)**

Subcommand	Entry	Explanation
HELP	HELP	Help. Enter HELP to display online documentation about this rating test (RATE) program and a list of available subcommands.
Q	Q <command>	Query command. Enter the subcommand name for a detailed explanations of each of the available subcommands.
QUIT	QUIT	Quit. Enter QUIT at the MAP terminal to exit from the RATE program menu and return back to the command interpreter (CI) level.
SHOW	SHOW	Show current settings. Enter SHOW to display on the MAP terminal all current entries of all subcommands.
CLG	0 to 9 (10 digits) or blank	Calling number. Enter the calling number. If the entry is left blank, the previous setting is displayed as current.
DOL	DOM, LCL, OVS, or blank	Traffic Operator Position System call type. Enter the call type: <ul style="list-style-type: none"> <li>• DOM (domestic)</li> <li>• LCL (local)</li> <li>• OVS (overseas)</li> </ul> If the entry is left blank, the previous setting is displayed as current.
CLD	0 to 9 (10 digits) or blank	Called number. Enter the called number. If the entry is left blank, the previous setting is displayed as current.

**SCHNUM** (continued)

**Subcommands for RATE program (Sheet 2 of 5)**

Subcommand	Entry	Explanation	
BIL	AUTO_COL	Billing type. Enter the billing type.	
	PCB_PD		
	PCB_SPL_		
	CLG		
	PER_COL		
	PER_PD		
	PER_SPL_		
	CLD		
	PCB_SPL_		
	CLG		
SPL	STA_COL	Special number type. Enter the special number type if applicable. If the entry is left blank, the previous setting is displayed as current.	
	STA_PD		
	STA_SPL_CLD		
	STA_SPL_		
	CLG or		
	UNKNOWN		
	DOM_CC		Special number type. Enter the special number type if applicable. If the entry is left blank, the previous setting is displayed as current.
	DOM_3RD		
	OVS_CC		
	OVS_3RD		
NONE or			
blank			
OSC	CN, HTL, NCN, or blank	Originating station class. Enter the originating station class: <ul style="list-style-type: none"> <li>• CN (coin)</li> <li>• HTL (hotel)</li> <li>• NCN (noncoin)</li> </ul> If the entry is left blank, the previous setting is displayed as current.	
	CN, HTL, NCN, or blank	Terminating station class. Enter the terminating station class: <ul style="list-style-type: none"> <li>• CN (coin)</li> <li>• HTL (hotel)</li> <li>• NCN (noncoin)</li> </ul> If the entry is left blank, the previous setting is displayed as current.	

**SCHNUM** (continued)**Subcommands for RATE program (Sheet 3 of 5)**

Subcommand	Entry	Explanation
CAT	DD, OA, OH, or blank	<p>Call type. Enter the call type:</p> <ul style="list-style-type: none"> <li>• DD (direct dialed)</li> <li>• OA (operator assisted)</li> <li>• OH (operator handled)</li> </ul> <p>If the entry is left blank, the previous setting is displayed as current.</p>
TAC	Y, N, or blank	<p>Time and charge. Enter Y (yes) to indicate that time and charge are used. Enter N (no) to indicated that time and charge are not used.</p> <p>If the entry is left blank, the previous setting is displayed as current.</p>
DRT	Y, N, or blank	<p>Dial rate key. Enter the simulation of the dial rate key used. Enter Y if the call is treated as station rate. Otherwise enter N.</p> <p>If the entry is left blank, the previous setting is displayed as current.</p>
SOC	mmm, dd, hh, mm, and ss, or blank	<p>Start of call time. Enter the month, day, hour, minute, and second of the start time of the simulated test call. (The test call time must be prior to the RATE test time.)</p> <p>If the entry is left blank, the previous setting is displayed as current.</p>
DUR	0 to 9 or blank	<p>Call duration. Enter the duration of the simulated test call in minutes.</p> <p>If the entry is left blank, the previous setting is displayed as current.</p>
RS	0 to 9 or blank	<p>Rate step. Enter the rate step if RATE test cannot calculate it.</p> <p>If the entry is left blank, the previous setting is displayed as current.</p>

**SCHNUM** (continued)**Subcommands for RATE program (Sheet 4 of 5)**

Subcommand	Entry	Explanation
USE	ACTIVE INACTIVE or blank	Table usage. Enter active or inactive to indicate the set of TOPS rating data tables used.  If the entry is left blank, the previous setting is displayed as current.  <b>Note:</b> Refer to table CHARGEI for a description of TOPS Mass Table Control and the differences between active and inactive tables. If a government-dictated rate change occurs, the operating company puts the new rate schedules in the set of inactive tables and uses this RATE program to test them.
CAR	0to9 (3digits) or NNN	Carrier number. Enter the carrier identification number from table CARRTRF to test the rating of TOPS inter-lata (local access and transport area) carrier service. This numeric value must be enclosed in single quotation marks ('). Enter NNN to rate a non-carrier call.
CR	CR	Calculate rate step. Enter CR to calculate the rate step based on the current setting of the above subcommands. The calculated rate step is displayed on the MAP terminal.
CALC_CHG	CALC_CHG	Calculate charge. Enter CALC_CHG to calculate the charges to the test call if the rate step is known.
CB	CB	Calculate both. Enter CB to calculate both the rate step and the charges based on the current settings of the above subcommands.



**SCHNUM** (continued)**Subcommands for RATE program (Sheet 5 of 5)**

Subcommand	Entry	Explanation
DCC	AUTO NONE or OH	<p>Directory assistance call completion. Enter the call completion type:</p> <ul style="list-style-type: none"> <li>• AUTO (automatic)</li> <li>• NONE (directory assistance (DA) call completion not allowed)</li> <li>• OH (operator handled)</li> </ul> <p>This subcommand indicates the rate (direct dialed or operator assisted) and the type of call completion applied to the call from table DACCSUR.</p>
DCS	Y or N	<p>Directory assistance call completion surcharge. Enter Y to indicate a surcharge from table DACCSUR is included if calculating the charges for the simulated call. The surcharge is based on the type of call completion allowed for the call. Otherwise enter N.</p>

**RATE CI increment**

The user must enter the RATE CI increment (enter RATE from the CI level of a MAP terminal), to use the rate subcommands to specify the relevant call details (for example, calling number, called number) and request rate step, charge calculation, or both.

For example, the user keys the following sequence of commands (text is description only).

**Examples of RATE commands (Sheet 1 of 2)**

Command entered	Explanation
RATE	Enter the RATE CI increment.
CLG 6132265400	Assign a value to the calling number variable.
COL DOM	Called number classification (domestic [DOM], OVS [overseas], or LOC [local]).
CLD 2122201234	Called number.
BIL STA_PD	Billing type.

**SCHNUM** (continued)**Examples of RATE commands (Sheet 2 of 2)**

Command entered	Explanation
SPL NONE	Special number type (credit card, third, and so on).
OSC CN	Originating station class (coin, hotel, and so on).
TSC NCN	Terminating.
CAT OH	Call type (operator handled, operator assisted, and so on).
TAC N	Time and charges requested.
DRT N	Dial rate.
DUR 3	Call duration (minutes).
SOC DEC 31 23 59 59	Start of call.
USE ACTIVE	Use active or inactive rating data.
CAR	Determine whether a carrier number is required.
CB	Request both rate step and charge calculation.
QUIT	Leave the RATE CI increment.

**Command SHOW**

Command SHOW displays the following data:

```

USE =   CLG = 2134567890
DOL = DOM   CLD = 6135441234BIL = STA_PD
SPL = NONE  OSC = CNTSC = NCN
CAT = OHTAC = N DRT = N
DUR = 1 SOC = THU. 1981 JAN 1 23:59:59

```

The current value of the rate step (RS) variable is not displayed here. It is displayed by command CALC\_CHG.

**SCHNUM** (continued)**Command CR**

Command CR invokes the rate step calculator. It displays data using one of the following formats:

```

USE = INACTIVE  CLG = 2134567890
COL = DOM     CLD = 6135441234BILL = STA_PD
STARTING RATE STEP CALCULATION ...
COULD NOT CALCULATE RATE STEP
USE = ACTIVECLG = 2134567890
DOL = OVS     CLD = 33123456789   BILL = PER_PD
STARTING RATE STEP CALCULATION
RS = 456

```

**Command CALC\_CHG**

If a rate step is known, command CALC\_CHG invokes the charge calculator. It displays data using one of the following formats:

RATE STEP NOT PRESENT

*or*

```

RS = 678
USE = INACTIVE  CLG = 2134567890
DOL = DOM     CLD = 6135441234TSC = NCN
SPL = NONE    OSC = HTL   TSC = NCN
CAT = OHTAC = N DRT = N
DUR = 000     SOC = WED. 1980 DEC 31 23:59:59
STARTING CHARGE CALCULATION ... COULD NOT CALCULATE
CHARGES

```

*or*

```

RS = 350
USE = INACTIVE  CLG = 2134567890
DOL = LOC     CLD = 5441234   BIL = STA_PD
SPL = NONE    OSC = CNTSC = NCN
CAT = OHTAC = N DRT = N
DUR = 100     SOC = THU. 1981 JAN 1 00:00:00
STARTING CHARGE CALCULATION ...
CHARGE = 80 TAX = 80

```

**Command CB**

Command CB displays data using one of the following formats:

## SCHNUM (continued)

---

```
USE = INACTIVE  CLG = 2134567890
DOL = DOM      CLD = 6135441234BILL = STA_PD
STARTING RATE STEP CALCULATION ...
COULD NOT CALCULATE RATE STEP
```

*or*

```
USE = ACTIVECLG = 2134567890
DOL = DOM      CLD = 6135441234BIL = STA_PD
STARTING RATE STEP CALCULATION ...
RS = 456
SPL = NONE    OSC = CNTSC = NCN
CAT = OHTAC = N DRT = N
DUR = 100     SOC = THU. 1981 JAN 1 23:59:59
STARTING CHARGE CALCULATION ...
COULD NOT CALCULATE CHARGES
```

*or*

```
USE = INACTIVE  CLG = 2134567890
DOL = DOM      CLD = 6135441234BIL = STA_PD
STARTING RATE STEP CALCULATION ...
RS = 456
SPL = NONE    OSC = HTL    TSC = NCN
CAT = OHTAC = N DRT = N
DUR = 100     SOC = THU. 1981 JAN 1 23:59:59
STARTING CHARGE CALCULATION ...
CHARGE = 65534  TAX = 6553
```

### **Commands CLG and CLD**

The CLG command must be a ten-digit number specified with it, along with a valid numbering plan area (NPA). The CLD number must be a ten-digit string.

### **Commands OSC, DOL, BIL, TSC, CAT, and SPL**

There are a set of legal operator values for each of these commands that are displayed if Q <subcommand> is entered.

---

**SCHNUM** (end)

---

**Command SOC**

Legal operator values are:

- month (JAN, FEB, MAR, APR, MAY, JUN, JUL, AUG, SEP, OCT, NOV, DEC)
- day (1 to 31)
- hr (0 to 23)
- min (0 to 59)
- sec (0 to 59)

If an incorrect month and day combination is specified (for example, JUN 31), an error message is displayed.

If command SOC is set with a legal date (for example, SOC DEC 31 23 59 59) or queried (that is, SOC), it displays data using the following format:

```
SOC = WED. 1980 DEC 31 23:59:59
```

The year selected is the last occurrence of the specified date. It is either `current_clock_year`, or `current_clock_year-1`.

**Command USE**

If the mass table control system is in the initial state, the following error message is displayed:

```
USE INACTIVE
```

**Command CAR**

If anything other than a non-numeric parameter or NNN is entered, the following message is returned:

```
CAR NUMBER MUST BE NUMERIC
```

If a parameter greater than three digits is entered, the following message is returned:

```
CAR NUMBER MUST BE THREE DIGITS
```

For either of the CAR subcommand error messages, the user must verify the type of information entered and ensure that it meets the entry values explained for this subcommand.

## SCRNAMES

### Table name

Screening Class Names Table

### Functional description

The screening class names for the trunk group tables appear in table SCRNAMES.

### Datafill

Datafill for table SCRNAMES appears in the following table.

#### Field descriptions

Field	Subfield or refinement	Entry	Explanation and action
VALUE		0 to 255	<i>Value.</i> Enter a different unsigned integer for each name. Assign the value 0 to the name NSCR (no screening class).
NAME		alphanumeric	<i>Screening class name.</i> Enter the screening class name that the operating company defines. This name represents the screening class that the gateway trunk group(s) use.

### Datafill example

Datafill for table SCRNAMES appears in the following example. Each screening class name in use requires one record.

#### MAP example for table SCRNAMES

VALUE	SYMBOL
0	NSCR
1	SC1C
2	SC1B

---

**SCRNCLAS**

---

**Table name**

List of Screening Class Names Table

**Functional description**

Table SCRNCLAS is required for initial loading and reloading of data. This table lists all the screening table names and the value that has been assigned to them. The value of 0 (zero) is assigned to the no screening class name NSCR.

The NA009 CLSVSCRC Table Expansion feature increases the number of classes of service defined by the operating company.

For related information, refer to table CLSVSCRC.

**Datafill sequence and implications**

There is no requirement to datafill other tables prior to table SCRNCLAS.

**Table size**

0 to 8000 tuples

**Datafill**

The following table lists datafill for table SCRNCLAS.

**Field descriptions**

Field	Subfield or refinement	Entry	Explanation and action
VALUE		0 to 8000	<i>Value</i> Enter the numeric value assigned to the class of screening subtable name. Any entry outside the range indicated for this field is invalid.
SYMBOL		vector of up to 32 characters or NSCR	<i>Screening class name</i> If the entry in field VALUE is 0 (zero), enter NSCR. Otherwise, enter the name of the screening class.

**Datafill example**

An example of datafill for table SCRNCLAS in a combined local/toll switching unit is shown below. The example shows input data for the screening class NSCR, with a value of 0 (zero).

**SCRNCLAS** (end)

---

For other examples of table SCRNCLAS, see table CLSVSCRC and subtable CLSVSCR.

**MAP display example for table SCRNCLAS**

VALUE	SYMBOL
0	NSCR



---

**SCRGRP**

---

**Table name**

Screen Group (SCRGRP)

**Functional description**

Table SCRGRP is used to store screening groups (SCRGRPS) for Primary Rate Interface (PRI) Calling Number (CGN)/Redirecting Number (RN) routing. These screening groups consist of up to 180 National Integrated Services Digital Network-2 (NI-2)/Nortel North America (NTNA) Logical Terminal Identifiers (LTID).

Table SCRGRP only supports NI-2 and NTNA. The NI-2 and NTNA screening groups are referenced by Table DNSCRN.

The SCRGRP name must not exceed 16 characters. All LTIDs provisioned in Table SCRGRP must be PRI LTIDs. The maximum number of LTIDs that can be installed on a DMS is 2172.

**Datafill sequence and meaning**

An LTID must be provisioned in Table LTDEF before it can be provisioned against a SCRGRP in Table SCRGRP.

Enter datafill into the table that follows after you enter datafill into table SCRGRP:

- DNSCRN

**Table size**

0 to 1024

## SCRGRP (end)

### Datafill

The table that follows lists datafill for table SCRGRP.

#### Field descriptions

Field	Subfield	Entry	Explanation and action
SCRGNAME		Up to 16 alpha numeric characters	Each tuple of this table is stored physically as an array of 32766 booleans. This array represents every possible LTID combination (LTGRP * LTNUM). The implementation of this table allows a DN to be screened against up to 2172 LTIDs.
SCRGRPS	LTGRP	LOGICAL_TERMINAL_GROUP_NUMBER	This subfield represents the NI-2/NTNA logical terminal group number.
	LTNUM	1-1022	This subfield represents the logical terminal number.
<b>Note:</b> SCRGRP must exist in Table SCRGRP			

### Datafill example

The figure that follows shows sample datafill for table SCRGRP.

#### MAP display example for table SCRGRP

```

SCRGNAME SCRGRPS
PGRP1 ( ISDN 1) (ISDN 2) ... ( ISDN 180)$
PGRP2 ( SPRI 1) (SPRI 2) ... ( SPRI 180)$
    
```

### Table history

#### NA015

Added Table SCRGRP in the NA015 release for the PRI DN Screening LTID Enhancement Feature.

**SCRNNAME****Table name**

Screening Name Table

**Functional description**

Table SCRNNAME allows the definition of screening class names that can later be used in tables TOPEACAR and TOPEATRM.

Screening names must be datafilled here before they can be used in tables TOPEACAR and TOPEATRM.

There are no default tuples to be included in this table.

**Datafill sequence and implications**

There is no requirement to datafill other tables prior to table SCRNNAME.

**Table size**

0 to 255 tuples

**Datafill**

The following table lists datafill for table SCRNNAME.

**Field descriptions**

Field	Subfield or refinement	Entry	Explanation and action
VALUE		see subfield	<i>Value.</i> This field consists of subfield UNINT.
	UNINT	0 to 32	<i>Unit integer</i> This is the key field of the table. Enter the integer value.  Indicated values outside this range are not valid.
SYMBOL		1 to 32 characters	<i>Symbol</i> Enter the screening name used in tables TOPEATRM (field SCRNNAME) and TOPEACAR (fields INSCRN and NASCRN). Names of eight characters or less are recommended to prevent table formats from expanding to accommodate the longer names.

**SCRNNAME** (continued)**Datafill example**

The following example shows sample datafill for table SCRNNAME.

**MAP display example for table SCRNNAME**

VALUE	SYMBOL
0	IN1
1	IN2
2	NA3

**Supplementary information**

This section provides information on datafilling table SCRNNAME for specific applications, and product descriptive information related to table SCRNNAME.

The TOPS Equal Access Screening tables provide DMS-200 TOPS offices with the ability to determine if an InterExchange Carrier (IEC) can complete a domestic, international or zero-minus call to a given NPA (or NPA-NXX) or country. The call must have already been identified as a carrier call. If a carrier can complete a call to the terminating destination, then the call can be forwarded to that carrier. Table TOPEATRM provides this screening. A screening name from table TOPEACAR and the called digits for the call are used to index table TOPEATRM when terminating points screening is required for a carrier call. Definition of the screening names is provided by table SCRNNAME.

**Screening for domestic calls**

Field NATERM in table TOPEACAR if a given carrier is restricted in its ability to complete calls dialed with the national dialing plan. If the carrier can complete all national calls, then screening based on the terminating NPA or NPA-NXX is not required. In this case, the NATERM field is set to UNREST, which indicates the carrier is unrestricted. If the carrier cannot complete any national dialed calls, then the field can be set to DENY. With DENY, all calls are disallowed so terminating points screening is not performed.

If a carrier wants to receive all national calls, even calls that cannot be completed, then NATERM should be set to UNREST. This can occur if a carrier wants to receive calls and connect them to an announcement that informs the subscriber how to dial instead of having the Operating Company automatically choose an alternate for the call.

---

**SCRNNAME** (end)

---

If the carrier can complete some national calls but not others, then NATERM is set to RESTRICT. When RESTRICT is datafilled as the value for this field, then terminating points screening is required for national calls. RESTRICT causes the NASCRN subfield to appear since a screening class name is required for this type of screening. The name datafilled in NASCRN, together with the called number, is used to index table TOPEATRM during screening.

**Screening for international calls**

The INTERM field in table TOPEACAR has the same function and same possible values as the NATERM field, but it applies to international calls. The values UNREST and DENY are used if the carrier can complete either all or none of the international calls, respectively. If the carrier can only complete calls to certain countries, then the RESTRICT value is given in INTERM. When RESTRICT is given, the INSCRN subfield must be datafilled with a screening name to be used, with the called number, as an index into table TOPEATRM.

**Screening table structure**

Table TOPEATRM is indexed using a screening class name (from either NASCRN or INSCRN in TOPEACAR) and the called digits. As mentioned above, TOPEATRM is only accessed when a carrier can complete some, but not all, national or international terminating points. When table TOPEATRM is indexed and the screening name-called number combination is found to be present in the table, then the carrier is considered capable of completing calls to that destination. So, to datafill table TOPEATRM for a given carrier's national calls, the carrier's screening name together with the NPA's and/or NPA-NXX's that the carrier can support must be included in the table.

Different screening names must be used for screening national and international calls, since there is overlap in the digit patterns for the two dialing plans. If two or more carriers have the same restrictions for call completion, then they can share the same screening name. Sharing data this way reduces the amount of datafill required in table TOPEATRM. However, if the areas supported by the carriers are expected to change, then updating the table can be easier when different screening names are used for the carriers. All screening names must be defined in table SCRNNAME before datafilling in tables TOPEACAR and TOPEATRM.

## SCUFEAT

---

### Table name

Speed Calling User Feature Table

### Overview

The Speed Calling Long List (SCL) feature, which is assigned to Integrated Business Network (IBN) lines and keyset lines in tables IBNFEAT and KSETFEAT respectively, enables a customer to place calls to any number within a previously designated list of frequently called numbers by dialing a two-digit speed calling code instead of the complete number. The list of frequently called numbers is referred to as a speed calling long list. This list can consist of 30, 50, or 70 numbers.

A speed calling long list can be accessed by a number of users, in which case it becomes a group speed calling list. Only one line, called the controller, can change the contents of this list.

### Functional description

Table SCUFEAT enables IBN and keyset lines that are not assigned feature SCL to become speed calling users (SCU). SCUs can access another station's speed calling long list. The speed calling long list cannot be updated, added, or deleted by the SCU.

### Datafill sequence and implications

Datafill tables IBNFEAT and KSETFEAT prior to table SCUFEAT. This ensures that the line equipment number (LEN) of the controller is datafilled.

### Table size

0 to 25 000 tuples

**SCUFEAT** (continued)**Datafill**

The following table lists datafill for table SCUFEAT.

**Field descriptions (Sheet 1 of 2)**

Field	Subfield or refinement	Entry	Explanation and action
LEN		see subfields	<p><i>Line equipment number</i></p> <p>This field defines the physical location of the equipment that is connected to a specific telephone line.</p> <p>Because field LEN is common to more than 60 tables, it is documented in a single section to avoid unnecessary duplication. Refer to section "Common entry field LEN" for a complete description of field LEN and associated subfields.</p> <p>For ISDN lines, field LEN consists of subfield LTID. For non-ISDN lines, field LEN consists of subfields SITE, FRAME, UNIT, DRAWER or LSG, SHELF, SLOT, and CIRCUIT.</p>
SCUSER		IBN or KSET	<p><i>Speed calling user</i></p> <p>If the line is an Integrated Business Network (IBN) line, enter IBN and datafill refinements CONTLEN and TDN.</p> <p>If the line is a keyset or data-unit line, enter KSET and datafill refinements KEY, CONTLEN, and TDN.</p>
	KEY	numeric (1 to 69)	<p><i>Key</i></p> <p>If the entry in field SCUSER is KSET, enter the number of the physical keyset to which the Speed Calling User feature must be assigned.</p> <p>If assigned as a code access feature, the entry value must be 1.</p>

**SCUFEAT** (continued)

## Field descriptions (Sheet 2 of 2)

Field	Subfield or refinement	Entry	Explanation and action
	CONTLEN	see subfields	<p><i>Line equipment number</i></p> <p>This field defines the physical location of the equipment that is connected to a specific telephone line.</p> <p>Because field LEN is common to more than 60 tables, it is documented in a single section to avoid unnecessary duplication. Refer to section "Common entry field LEN" for a complete description of field LEN and associated subfields.</p> <p>For non-ISDN lines, field LEN consists of subfields SITE, FRAME, UNIT, DRAWER or LSG, SHELF, SLOT, and CIRCUIT.</p>
	TDN	Y or N	<p><i>Toll denied</i></p> <p>Enter Y (yes) to specify that the caller cannot use speed calling numbers that translate to a toll number. Enter N (no) to specify that the caller can use speed calling numbers of this type. This choice applies regardless of whether the line of the caller specifies toll denial for regular dialed calls.</p>

**Datafill example**

An example of datafill for table SCUFEAT is shown below. In this example, the feature is assigned as code access to a keyset with a LEN of 00 0 09 15 at the host switching unit.

This line has access to the speed calling long list assigned to the line with LEN 00 0 10 15, and can use speed calling numbers that translate to a toll number.



**SCUFEAT** (end)

**MAP display example for table SCUFEAT**

LEN	SCUDATA
HOST 00 0 09 15	
KSET 1	HOST 00 0 10 15 N

## SDGRP

---

### Table name

Signal Distributor Group Table

### Functional description

Table SDGRP contains the product engineering code (PEC) of the signal distributor (SD) groups reserved for use as SD points for line features. This table contains the physical location at the host or remote switching units of these SD groups.

The maximum number of SD groups assigned to line features is 512 (0 to 511).

Assignment of the physical locations of the SD groups for line features cannot occur in alarm and network management SD groups.

Refer to table ALMSDGRP and table NWMSD for information on alarm and network management SD groups.

Each SD card with PEC NT2X57AA provides 14 SD points. The SD card contains two SD groups. Each SD group contains seven SD points (0 to 6). Assign each SD to a trunk module circuit number.

The operating company can assign the seven SD points in the SD group. The operating company can assign these SD points to lines with a minimum of one of the following features. Each feature requires one SD point.

The following lines require each SD point:

- lines in table LENLINES with the following features:
  - Sleeve Lead Control (FRO)
  - Sleeve Leads for Public Fire Reporting System (FRS)
  - Remote Meter Pulsing (RMP)
  - Remote Register and Signal Distributor (SD) Point (RMS)
- lines in table IBNLINES with the Sleeve Lead Control (FRO) feature

Refer to table LENFEAT for information on line features FRO, FRS, RMP and RMS for lines in table LENLINES.

Refer to table IBNFEAT for information on line feature FRO for lines in table IBNLINES.

You must assign lines in the host switching unit to SD points that belong to specified SD groups. These SD groups are in the host switching unit.

**SDGRP** (continued)

You must assign lines at the remote location to SD points that belong to specified SD groups. These SD groups are in the remote location.

**Datafill sequence and meaning**

Enter data in tables DATASIZE and TMINV before you enter data in table SDGRP.

**Table size**

Before CSP02, the value of field SIZE allocates memory for this table. The value of field SIZE is in table DATASIZE for the entry that has field DATSKEY set to SDGRP.

For CSP02 and later versions, a table size increase does not require a restart. Table DATASIZE does not require tuple SDGRP. To extend the length of the table before CSP02, you had to increase the size of table DATASIZE. After you increased the size of the table, you had to perform a cold restart.

*Note:* If the NORESTARTSWACT utility is available on your switch, you can activate data changes without interrupting service. Refer to *NORESTARTSWAC/MTCWACT User's Guide*.

**Datafill**

Datafill for table SDGRP appears in the following table.

**Field descriptions (Sheet 1 of 2)**

Field	Subfield or refinement	Entry	Explanation and action
SDGRPNO		see subfield	<i>Signal distributor group key.</i> This field contains subfield SDGRPNO.
	SDGRPNO	0 to 511	<i>Signal distributor group.</i> Enter the signal distributor (SD) group number.
TMTYPE		MTM, RMM, or RSM	<i>Trunk module type.</i> Enter the type of trunk module that contains the SD card. Trunk module types include MTM (maintenance trunk module), RMM (remote maintenance module), and RSM (remote service module).
TMNO		0 to 2047	<i>Trunk module number.</i> Enter the number assigned to the MTM, RMM, or RSM that contains the SD card.

**SDGRP (end)**

**Field descriptions (Sheet 2 of 2)**

Field	Subfield or refinement	Entry	Explanation and action
TMCKTNO		0 to 29	<i>Trunk module circuit number.</i> Enter the trunk module circuit number on the MTM, RMM, or RSM which has SD group assigned.
CARDCODE		2X57AA	<i>Cardcode.</i> Enter the product engineering code (PEC) of the SD card, 2X57AA.  The system does not accept entries outside the range for this field.

**Datafill example**

Sample datafill for table SDGRP appears in the following example. The SD groups 0 and 1 are in the host switching unit. The SD groups 2 and 3 are at the Merivale (MERV) remote location.

See the datafill examples for tables IBNFEAT and LENFEAT for the assignment of each signal distributor point in the SD group.

**MAP example for table SDGRP**

SDGRPNO	TMTYPE	TMNO	TMCKTNO	CARDCODE
0	MTM	0	14	2X57AA
1	MTM	0	15	2X57AA
2	RSM	0	14	2X57AA
3	RSM	0	15	2X57AA

**Table history**

**CSP02**

A sentence was added in CSP02. This sentence indicated that a restart is not required to increase table size. Table DATASIZE does not require an entry for table SDGRP.

**BCS36**

Field SDGRPNO was added in BCS36. A reference to the NORESTARTSWACT utility was added in this release.

---

**SDMBILL**

---

**Table name**

SDMBILL

**Functional description**

The SDMBILL table is used to store information pertaining to the SDM billing platform on a by stream basis. The fields indicate either a billing stream is sent to the SuperNode Data Manager (SDM), Device Independent Recording Package (DIRP) or both. The fields holds the volumes (one or two) chosen for backup of the billing data.

There are CI commands available at the MAP level of SDMBILL (MAPCI;MTC;APPL;SDMBIL) that allows the user to adjust and view the tuples in the table. The table automatically contains all of the streams that are datafilled in table CRSFMT. The tuples are automatically deleted if the tuples are removed from table CRSFMT. This is the only way the tuples can be deleted from table SDMBILL. The stream's SDMBACT field needs to be OFF before deleting the stream from CRSFMT.

**Datafill sequence and implications**

Table CRSFMT must be datafilled before table SDMBILL. The datafill occurs automatically, adding a tuple for each stream.

**Table size**

The maximum number of tuples is 16. Each tuple will be 11 words long. The entire table will be allocated when initialized. It is a relatively small table and remains static in size.

**SDMBILL** (continued)**Datafill**

The following table lists datafill for table SDMBILL.

**Field descriptions (Sheet 1 of 2)**

Field	Subfield or refinement	Entry	Explanation and action
SDMBKEY		up to 16 characters	SuperNode Data Manager billing key. This is the key to the table. This is the call data stream name that is automatically datafilled from table CRSFMT field KEY to synchronize the two tables.
SDMBACT		ON, OFF, or BOTH	<p>SuperNode Data Manager billing activation.</p> <ul style="list-style-type: none"> <li>ON sends billing data to the stream for SDM only.</li> <li>OFF only sends billing data to the stream for DIRP.</li> <li>BOTH sends billing data to the SDM and DIRP.</li> </ul> <p>The SDMBCTRL command can be used to modify this field which is a hidden menu command at the SDMBILL map level.</p> <p>Default: The default value is OFF.</p> <p><b>Note:</b> Even though there may be several streams in the table, only the BCFMT format stream (AMA, which is hard coded to 1) is allowed to be turned to ON, or BOTH for the first release.</p>
SDMBSTAT		Insv, ISTb, ManB, Bkup, Rcvy, RBsy, Off, OffP, or SysB	<p>SuperNode Data Manager billing status. This field indicates the current status of the stream, given in field SDMBKEY.</p> <p>This field is automatically datafilled as table CRSFMT is datafilled.</p>

**SDMBILL** (end)**Field descriptions (Sheet 2 of 2)**

Field	Subfield or refinement	Entry	Explanation and action
VOLUME1		up to 8 characters	Volume 1 The CONF menu command can be used to modify this field which is a hidden menu command at the SDMBILL map level.
VOLUME2		up to 8 characters	Volume 2 The CONF menu command can be used to modify this field which is a hidden menu command at the SDMBILL map level.

**Datafill example**

The following example shows sample datafill for table SDMBILL.

**MAP display example for table SDMBILL**

SDMBKEY	SDMBACT	SDMBSTATUS	VOLUME1	VOLUME2
NIL	OFF	OFF	\$	\$
AMA	OFF	OFF	\$	\$

**Table history****SBA08**

The SuperNode Data Manager (SDM) Billing Enhancements, feature AF6912; adds a new field SDMBSTATUS.

**CSP07**

The Automatic Message Accounting Data Networking System (AMADNS) Operations, Administration, Maintenance, and Provisioning (OAM&P), feature AF6525 introduces table SDMBILL.

## SDMINV

---

### Table name

SDM Inventory (SDMINV) Table

### Functional description

The SDMINV table contains datafill for both the SuperNode Data Manager (SDM) Fault-tolerant (FT) and Simplex SX platforms. The SX platform is a nonredundant system based on the FT platform. The SX platform contains cards on one side of the SDM only.

This table description contains configuration data for both the FT and SX platforms. This data includes message switch (MS) port definitions, locations and IP addresses.

*Note:* The SDM Simplex Versa Module Eurocard (VME) platform does not require datafill in the SDMINV table. The VME platform is manufacture discontinued (MD).

### Datafill sequence and meaning

Enter datafill in the following tables before you enter datafill in the SDMINV table:

- MSCDINV
- IPNETWRK

### Table size

The maximum number of SDMs that can contain datafill determines the size of the SDMINV table. This maximum is currently one. The SDMINV table accommodates only one tuple.



**SDMINV** (continued)**Datafill**

Datafill for the SDMINV table appears in the following table.

**Field descriptions (Sheet 1 of 2)**

<b>Field</b>	<b>Subfield or refinement</b>	<b>Entry</b>	<b>Explanation and action</b>
SDM		0	<i>SuperNode Data Manager number.</i> This field is the key to the SDMINV table. This field identifies the SDM number. Enter 0.
CONFIG		FT or SIMP	<i>SuperNode Data Manager configuration.</i> This field identifies the configuration of the SDM.  Enter FT for a Fault-tolerant platform.  Enter SIMP for a Simplex SX platform.
FLOOR		0 to 99	<i>Floor location.</i> Enter the floor number that contains the SDM.
ROW		A to Z, or AA to ZZ	<i>Row location.</i> Enter the row on the floor that contains the SDM. I, O, II, and OO are not valid entries.
POSITION		0 to 99	<i>SDM position.</i> Enter the position number of the cabinet that contains the SDM.
CABTYPE		CSDMorMISC	<i>Cabinet type.</i> Enter CSDM to specify the C28 Model B Streamlined cabinet for the SDM FT and SX platforms.MISC is the cabinet for the SDM Simplex VME platform. The MISC cabinet is manufacture discontinued (MD).
CABPEC		NTRX50FAor NT0X02BC	<i>Cabinet PEC.</i> Enter NTRX50FA (SDM cabinet for the SDM FT and SX platforms).NT0X02BC is the cabinet PEC for the SDM Simplex VME platform. This cabinet is manufacture discontinued (MD).
CABNUM		0 to 511	<i>Cabinet number.</i> Enter the cabinet number assigned to the cabinet.
SHELFPEC		NTRX50EB or NTRX52ELor NTRX50DA	<i>SDM shelf PEC.</i> Enter NTRX50EB for the SDM FT shelf.Enter NTRX52EL for the SDM SX shelf.NTRX50DA is the shelf PEC for the SDM Simplex VME platform. This shelf is manufacture discontinued (MD).

**SDMINV** (continued)

## Field descriptions (Sheet 2 of 2)

Field	Subfield or refinement	Entry	Explanation and action
SHELFPOS		0 to 77	<p><i>Shelf position.</i> This field identifies the vertical position in the SDM shelf cabinet.</p> <p>Enter the shelf position number of the SDM.</p>
IPADDR		0 to 255, 0 to 255, 0 to 255, 0 to 255	<p><i>Internet Protocol address.</i> Enter the IP address of the SDM. An IP address contains 4 bytes. Each byte contains a value in the range of 0 to 255. Separate each byte with a space.</p>
LINKRATE		SR128 or SR256	<p><i>Link subrate.</i> Enter the link subrate of the DS512 links to the SDM.</p> <p>The link subrate must correspond to the number of links entered for the message switch (MS) port card in the MSCDINV table.</p> <ul style="list-style-type: none"> <li>• If the MS port card contains four links, the subrate must be SR128.</li> <li>• If the MS port card contains two links, the subrate must be SR256.</li> </ul> <p><b>Note:</b> The system only supports SR256.</p>
LINKS			<p><i>Links.</i> This field is a vector that contains a maximum of two entries. These entries describe the links between the SDM and the MS. For a four-link configuration, such as the FT platform, use two entries. For a two-link configuration, such as the SX platform, use one entry. Each entry contains two subfields.</p>
	MS_CARD	1 to 26	<p><i>Message switch port card.</i> Enter a number between 1 and 26 to identify the MS port card number at the other end of the link.</p>
	MS_LINK	0 to 3	<p><i>Message switch link.</i> Enter a number between 0 and 3 to identify the MS link number at the other end of the link.</p> <p><b>Note:</b> Values of 0 and 1 are correct for SR256. Values of 0, 1, 2 and 3 are correct for SR128.</p>

**Datafill example**

The following examples show sample datafill for the SDMINV table.

**SDMINV** (end)**MAP display example for the SDMINV table (FT platform)**

SDM	CONFIG	FLOOR	ROW	POSITION	CABTYPE	CABPEC	CABNUM	SHELFPEC	SHELFPOS
IPADDR	LINKRATE	LINKS							
0	FT	0	Z	2	CSDM	NTRX50FA	0	NTRX50EB	10
47 35 7	10	SR256	(19	0)	(19	1)\$			

**MAP display example for the SDMINV table (SX platform)**

SDM	CONFIG	FLOOR	ROW	POSITION	CABTYPE	CABPEC	CABNUM	SHELFPEC	SHELFPOS
IPADDR	LINKRATE	LINKS							
0	SIMP	0	Z	2	CSDM	NTRX50FA	0	NTRX50EL	10
47 35 7	10	SR256	(19		(19	1)\$			

**Table history****CSP10**

Update to the SDMINV table:

- new PEC for SDM cabinet (NTRX50FA)
- new PEC for SDM Simplex SX shelf (NTRX52EL)

**TL06**

The SDMINV table was introduced in TL06.

**Additional information**

There is no additional information.

# SDSCUST

## Table name

Special Delivery Service Customer Group Information

## Functional description

This table enables the operating company to provision SDS messaging routing DNs for a particular customer group. When this table is datafilled, Access to Messaging calls are routed from subscribers in the customer group that is named in field CUSTNAME to the DNs specified in this table, rather than to the DNs specified in table SDSINFO.

## Datafill sequence and implications

Table CUSTENG must be datafilled before table SDSCUST.

## Table size

0 to 4096 tuples

## Datafill

The following table lists datafill for table SDSCUST.

### Field descriptions (Sheet 1 of 2)

Field	Subfield or refinement	Entry	Explanation and action
CUSTNAME		alphanumeric (1 to 16 characters)	<i>Customer name</i> This field specifies the customer group name as defined in table CUSTENG.
INTERBSY		A DN with 7, 10 or more (up to 30) digits	<i>SDS messaging routing DN for interLATA busy calls for a customer group</i> This field specifies the SDS messaging routing DN for interLATA busy calls to be used for the customer group that is entered in field CUSTNAME.
INTERRNA		A DN with 7, 10 or more (up to 30) digits	<i>SDS messaging routing DN for interLATA ringing/no-answer calls for a customer group</i> This field specifies the SDS messaging routing DN for interLATA ringing/no-answer calls to be used for the customer group that is entered in field CUSTNAME.

**SDSCUST** (end)**Field descriptions (Sheet 2 of 2)**

Field	Subfield or refinement	Entry	Explanation and action
INTRABSY		A DN with 7, 10 or more (up to 30) digits	<i>SDS messaging routing DN for intraLATA busy calls for a customer group</i>  This field specifies the SDS messaging routing DN for intraLATA busy calls to be used for the customer group that is entered in field CUSTNAME.
INTRARNA		A DN with 7, 10 or more (up to 30) digits	<i>SDS messaging routing DN for intraLATA ringing/no-answer calls for a customer group</i>  This field specifies the SDS messaging routing DN for intraLATA ringing/no-answer calls to be used for the customer group that is entered in field CUSTNAME.

**Datafill example**

The following example shows sample datafill for table SDSCUST.

**MAP display example for table SDSCUST**

CUSTNAME	INTERBSY	INTERRNA	INTRABSY	INTRARNA
COMKODAK	15143451001	3451002	3451003	16133451004

**Table history****NA005**

New table

## **SDSINFO**

---

### **Table name**

Special Delivery Service Information

### **Functional description**

Table SDSINFO enables the operating company to control the operation of the following features in an end office: Access to Messaging, Enhanced Busy Call Return (EBCR), FAX-Thru Service (FTS).

The following SDSINFO tuples must be datafilled for Access to Messaging to operate: OFFICE, SDSOFC, SDSRNA, and SDSBSY.

The following SDSINFO tuples must be datafilled for Enhanced Busy Call Return to operate: OFFICE, SDSOFC, SDSRNA, and SDSBSY.

The following SDSINFO tuples must be datafilled for FAX-Thru Service to operate: OFFICE and FTS.

### **Datafill sequence and implications**

Tables CLLI, ANNS, ANNMEMS, DRAMTRK and DRMUSERS must be datafilled before table SDSINFO. Specifically, the values contained in fields BSYHELP, RNAHELP, MSGANNC (values in both tuples SDSBSY and SDSRNA), ACBANNC, and ACBMSGAN of table SDSINFO must be datafilled in table CLLI prior to datafilling table SDSINFO.

### **Table size**

The minimum size of table SDSINFO is 0 (zero) tuples. The maximum size of table SDSINFO is 5 tuples.

**SDSINFO** (continued)**Datafill**

The following table lists datafill for table SDSINFO.

**Field descriptions of table SDSINFO**

Field	Subfield or refinement	Entry	Explanation and action
SDSKEY		OFFICE, SDSOFC, SDSRNA, SDSBSY, or FTS	<p>Special Delivery Service Key. This key, in combination with the Service field, provides access to the different tuples of table SDSINFO, which contain the datafill information required for Access to Messaging, Enhanced Busy Call Return, and FAX-Thru Service.</p> <p>Entry OFFICE accesses the OFFICE tuple. Entry SDSOFC accesses the SDSOFC tuple. Entry SDSRNA accesses the SDSRNA tuple. Entry SDSBSY accesses the SDSBSY tuple. Entry FTS accesses the FTS tuple.</p>
SERVICE		OFFICE, SDSOFC, SDSRNA, SDSBSY, or FTS	<p>Service selector. This selector, in combination with the SDSKEY field, provides access to the different tuples of table SDSINFO, which contain the datafill information required for Access to Messaging, Enhanced Busy Call Return, and FAX-Thru Service.</p> <p>Entry OFFICE accesses the OFFICE tuple. Entry SDSOFC accesses the SDSOFC tuple. Entry SDSRNA accesses the SDSRNA tuple. Entry SDSBSY accesses the SDSBSY tuple. Entry FTS accesses the FTS tuple.</p> <p><b>Note:</b> The same value must be entered in the SDSKEY and SERVICE fields.</p>

**SDSINFO** (continued)**Datafill for table SDSINFO tuple OFFICE**

The following table lists the datafill required in table SDSINFO tuple OFFICE.

**Field descriptions of table SDSINFO tuple OFFICE (Sheet 1 of 4)**

Field	Subfield or refinement	Entry	Explanation and action
	BILLING	Y or N	<p>Billing. This field specifies whether billing is allowed on the call to message routing DN (used by Access to Messaging) and on calls to a FTS routing DN (used by FAX-Thru Service).</p> <p><b>Note:</b> If the call to the message routing DN is an equal access call or a Number Service Code (NSC) call (for example, an 800 number), the AMA record for the call is generated, even if field BILLING is set to N.</p> <p>Field BILLING pertains to Access to Messaging and FAX-Thru Service. Though it does not pertain to Enhanced Busy Call Return, this field must be datafilled for Enhanced Busy Call Return to operate.</p> <p>This field does not affect billing if an Alternate Service Provider offers Access to Messaging service.</p>
	REVLXLA	Y or N	<p>Reverse translations. This field specifies whether reverse translations are needed in order to determine the NPA of the called party (when it is not dialed).</p> <p>Field REVLXLA pertains to Access to Messaging, Enhanced Busy Call Return, and FAX-Thru Service.</p>
	INTERLAT	Y or N	<p>InterLATA calls. This field specifies whether service(s) will be allowed on interLATA calls.</p> <p>Field INTERLAT pertains to Access to Messaging and FAX-Thru Service. Though it does not pertain to Enhanced Busy Call Return, this field must be datafilled for Enhanced Busy Call Return to operate.</p>



**SDSINFO** (continued)**Field descriptions of table SDSINFO tuple OFFICE (Sheet 2 of 4)**

Field	Subfield or refinement	Entry	Explanation and action
	DNSCRN	list of 3-digit NPAs or 6-digit NPA-NXXs (maximum of 51 entries)	<p>Directory number screening. This field specifies the range of digits for which service(s) will not be provided.</p> <p>Field DNSCRN pertains to Access to Messaging, Enhanced Busy Call Return, and FAX-Thru Service.</p>
	CFW	Y or N	<p>Call forwarding interaction. This field specifies whether service(s) will be offered on calls to parties that have one or more call forwarding features. For this functionality call forwarding refers to all types of call forwarding features, including AIN FORWARD_CALL response.</p> <p><b>Note 1:</b> Automatic Call Back (ACB) (the service to which Enhanced Busy Call Return provides access) cannot be activated, even if field CFW is set to Y, unless ACB supports the type of call forwarding feature that is present on the called party's line. The caller is still offered Enhanced Busy Call Return Service.</p> <p><b>Note 2:</b> On calls to DNs with AIN FORWARD_CALL response, if the AIN trigger is hit on the originating end office, Enhanced Busy Call Return is not offered to the caller, even if field CFW is set to Y.</p> <p>Field CFW pertains to Access to Messaging, Enhanced Busy Call Return, and FAX-Thru Service.</p>

**SDSINFO** (continued)

## Field descriptions of table SDSINFO tuple OFFICE (Sheet 3 of 4)

Field	Subfield or refinement	Entry	Explanation and action
	CONF	Y or N	<p>Conferencing interaction. This field specifies whether service(s) will be offered on the consultation leg of conference calls. Conference calls for this functionality refer only to the operation of conferencing features that make use of consultation legs, for example, Three-Way Call (3WC), Station Controlled Conference, Flexible Call, and Call Transfer.</p> <p>Field CONF pertains to Access to Messaging and Enhanced Busy Call Return. Though it does not pertain to FAX-Thru Service, this field must be datafilled for FAX-Thru Service to operate.</p>

**SDSINFO** (continued)**Field descriptions of table SDSINFO tuple OFFICE (Sheet 4 of 4)**

Field	Subfield or refinement	Entry	Explanation and action
	HNTGRP	Y or N	<p>Hunt group interaction (intraoffice). This field specifies whether service(s) will be offered on intraoffice calls that terminate on a hunt group.</p> <p><b>Note:</b> If table RESOFC tuple ACB field HUNTLINE is set to DENY, Automatic Call Back (ACB) (the service to which Enhanced Busy Call Return provides access) will not be activated on intraoffice calls terminating on a hunt group even if field HNTGRP is set to Y. Though ACB cannot be activated when field HUNTLINE is set to DENY, an announcement offering Enhanced Busy Call Return service to the caller will still be played when field HNTGRP is set to Y.</p> <p>Field HNTGRP pertains to Access to Messaging, Enhanced Busy Call Return, and FAX-Thru Service.</p>
	REJECTMT	BUSY or DISC	<p>Rejection treatment. This field specifies whether busy treatment (BUSY) or disconnect treatment (DISC) will be provided when a user rejects the service(s). The rejection treatment applies only to the busy condition.</p> <p>Field REJECTMT pertains to Access to Messaging and Enhanced Busy Call Return. Though it does not pertain to FAX-Thru Service, this field must be datafilled for FAX-Thru Service to operate.</p>

**Datafill example**

The following examples show sample datafill for table SDSINFO tuple OFFICE.

**SDSINFO** (continued)

---

**MAP display example for table SDSINFO tuple OFFICE**

SDSKEY SERVICE

---

OFFICE OFFICE Y N N (514845) (454)\$ Y Y N BUSY

OFFICE OFFICE N N N \$ Y Y Y DISC

**SDSINFO** (continued)**Datafill for table SDSINFO tuple SDSOFC**

The following table lists the datafill required in table SDSINFO tuple SDSOFC.

**Field descriptions of table SDSINFO tuple SDSOFC (Sheet 1 of 3)**

Field	Subfield or refinement	Entry	Explanation and action
	RPTKEY	0 to 9, NIL, or STAR	<p>Repeat announcement key. This field specifies the key that subscribers press to replay an offer of service announcement.</p> <p>Enter STAR when subscriber should press the * key on the telephone set.</p> <p><b>Note:</b> If *66 is datafilled as a valid acceptance sequence for EBCR service (table SDSINFO tuple SDSBSY field ACCEPT66 set to Y), then neither the help key nor the repeat key can be * (star).</p> <p>Field RPTKEY pertains to Access to Messaging and Enhanced Busy Call Return.</p>
	HELPKEY	0 to 9, NIL, or STAR	<p>Help announcement key. This field specifies the key that subscribers press to play a help announcement.</p> <p><b>Note 1:</b> Enter STAR when subscribers should press the * key on the telephone set.</p> <p><b>Note 2:</b> If *66 is datafilled as a valid acceptance sequence for EBCR service (table SDSINFO tuple SDSBSY field ACCEPT66 set to Y), then neither the help key nor the repeat key can be * (star).</p> <p>Field HELP_KEY pertains to Access to Messaging and Enhanced Busy Call Return.</p>

**SDSINFO** (continued)

## Field descriptions of table SDSINFO tuple SDSOFC (Sheet 2 of 3)

Field	Subfield or refinement	Entry	Explanation and action
	RNAHELP	see refinements	<p>Ringng/no-answer help announcement. This field identifies the ringing/no-answer help announcement using that announcement's CLLI code from table CLLI.</p> <p><b>Note:</b> This field requires an entry only if field HELP_KEY is a value other than NIL.</p> <p>Field RNAHELP pertains to Access to Messaging. Though it does not pertain to Enhanced Busy Call Return, this field must be datafilled for Enhanced Busy Call Return to operate.</p>
	STND	CLLI	This refinement specifies the CLLI for standard announcements. Datafill CLLI in table ANNMEMS.
	CUSTOM	ANNCLLI	This refinement specifies the CLLI for custom announcements. Datafill CLLI in table DRMUSERS.
		ANNID	This refinement specifies which custom announcement to play corresponding to CLLI.
	BSYHELP	see refinements	<p>Busy help announcement. This field identifies the busy help announcement using the announcement's CLLI code from table CLLI.</p> <p><b>Note 1:</b> This field requires an entry only if field HELP_KEY is a value other than NIL.</p> <p><b>Note 2:</b> Only one help announcement can be provided for the busy condition even when the busy offering is a choice of either Access to Messaging service or Enhanced Busy Call Return service.</p> <p>Field BSYHELP pertains to Access to Messaging and Enhanced Busy Call Return.</p>
	STND	CLLI	This refinement specifies the CLLI for standard announcements. Datafill CLLI in table ANNMEMS.

**SDSINFO** (continued)**Field descriptions of table SDSINFO tuple SDSOFC (Sheet 3 of 3)**

<b>Field</b>	<b>Subfield or refinement</b>	<b>Entry</b>	<b>Explanation and action</b>
	CUSTOM	ANNCLLI	This refinement specifies the CLLI for custom announcements. Datafill CLLI in table DRMUSERS.
		ANNID	This refinement specifies which custom announcement to play corresponding to CLLI.
	SDSSUBS	SUBSCR or UNIVER	Special Delivery Service subscription mode. This field specifies whether service(s) will be offered in Subscription (SUBSCR) mode or Universal (UNIVER) mode.  Field SDSSUBS pertains to Enhanced Busy Call Return.
	AMSGSUBS	SUBSCR or UNIVER	Access to Messaging subscription mode. This field specifies the subscription mode for access to messaging service.
	EXDIGCOL	0 to 10 (integer values only)	Extended digit collection period. This field specifies the number of seconds that the digit collection period will be extended beyond the normal digit collection period.  Field EXDIGCOL pertains to Access to Messaging and Enhanced Busy Call Return.
HUNTORIG		Y or N	Hunt Originator. When the operating company offers Access to Messaging and EBCR on an office-wide basis, this field determines whether these services are offered on calls that originate from members of hunt groups.
CTXORIG		Y or N	Centrex Originator. When the operating company offers Access to Messaging and EBCR on an office-wide basis, this field determines whether these services are offered on calls that originate from IBN, PSET, or ISDNKSET agents.
DPORIG		Y or N	Dial Pulse Originator. This field determines whether Access to Messaging and EBCR are offered on calls that originate from sets that use dial pulse signaling.

## SDSINFO (continued)

### Datafill example

The following example shows sample datafill for table SDSINFO tuple SDSOFC.

#### MAP display example for table SDSINFO tuple SDSOFC

```

SDSKEY  SERVICE
-----
SDSOFC  SDSOFC  1 0 STND HELPANN01 STND HELPANN02 UNIVER
SUBSCR  10 N N N

SDSOFC  SDSOFC  9 8 CUSTOM SDSCUSTANNC 1 STND
BUSYHELPANNC UNIVER SUBSCR 10 N N N
    
```

### Datafill for table SDSINFO tuple SDSRNA

The following table lists the datafill required in table SDSINFO tuple SDSRNA.

#### Field description of table SDSINFO tuple SDSRNA

Field	Subfield or refinement	Entry	Explanation and action
	RNAMODE	MSG or NONE	<p>Ringin/no-answer selector. This field specifies whether Access to Messaging service will be offered on the ringin/no-answer condition.</p> <p>If you select MSG, refer to "Datafill for table SDSINFO tuple SDSRNA selector MSG." This selector offers Access to Messaging service on the ringin/no-answer condition.</p> <p>None selector offers no service on the ring/no-answer condition.</p>

### Datafill example

The following example shows sample datafill for table SDSINFO tuple SDSRNA selector NONE.



---

**SDSINFO** (continued)

---

**MAP display example for table SDSINFO tuple SDSRNA selector NONE**

SDSKEY	SERVICE
SDSRNA	SDSRNA NONE

**SDSINFO** (continued)**Datafill for table SDSINFO tuple SDSRNA selector MSG**

The following table lists the datafill required in table SDSINFO tuple SDSRNA selector MSG.

**Field descriptions of table SDSINFO tuple SDSRNA selector MSG (Sheet 1 of 2)**

Field	Subfield or refinement	Entry	Explanation and action
	MSGACKEY	1 to 9	<p>Acceptance key for messaging. This field specifies the key that subscribers press to accept Access to Messaging service on the ringing/no-answer condition.</p> <p>Field MSGACKEY pertains to Access to Messaging.</p>
	RNATIMER	0 to 127	<p>Ringing/no-answer timer. This field specifies the number of seconds for the timer to run before the announcement offering Access to Messaging service will be played on ringing/no-answer calls.</p> <p><b>Note 1:</b> For Access to Messaging service to be offered, the value in field RNATIMER must be less than the value for the RNG_TMEOUT_NO_OF_SECS parameter datafilled in table OFCENG. If the value of RNATIMER is greater than the value in field RNG_TMEOUT_NO_OF_SECS, the switch will time out before Access to Messaging service can be offered. It is not recommended to make the values in the two fields identical, as having identical values in both fields will cause a racing condition between the two features.</p> <p><b>Note 2:</b> If field RNATIMER is set to 0 (zero), Access to Messaging service will never be activated on the ringing condition.</p> <p>Field RNATIMER pertains to Access to Messaging.</p>

**SDSINFO** (continued)**Field descriptions of table SDSINFO tuple SDSRNA selector MSG (Sheet 2 of 2)**

Field	Subfield or refinement	Entry	Explanation and action
	MSGANNC	see refinements	Announcement for messaging offer. This field identifies the announcement that offers Access to Messaging service on the ringing/no-answer condition using the announcement's CLLI code from table CLLI.  Field MSGANNC pertains to Access to Messaging.
	STND	CLLI	This refinement specifies the CLLI for standard announcements. Datafill CLLI in table ANNMEMS.
	CUSTOM	ANNCLLI	This refinement specifies the CLLI for custom announcements. Datafill CLLI in table DRMUSERS.
		ANNID	This refinement specifies which custom announcement to play corresponding to CLLI.
	INTERRNA	A DN with 7, 10, or up to 30 digits	Message routing DN for interLATA calls. This field specifies the message routing DN for interLATA ringing/no-answer calls.  Field INTERRNA pertains to Access to Messaging.
	INTRARNA	A DN with 7, 10, or up to 30 digits	Message routing DN for intraLATA calls. This field specifies the message routing DN for interLATA ringing/no-answer calls.  Field INTRARNA pertains to Access to Messaging.

**Datafill example**

The following example shows sample datafill for table SDSINFO tuple SDSRNA selector MSG.

**MAP display example for table SDSINFO tuple SDSRNA selector MSG**

SDSKEY	SERVICE
<hr/>	
SDSRNA	SDSRNA MSG 1 30 STND ANN_RNA 7211234 16137231235

**SDSINFO** (continued)

**Datafill for table SDSINFO tuple SDSBSY**

The following table lists the datafill required in table SDSINFO tuple SDSBSY.

**Field descriptions of table SDSINFO tuple SDSBSY**

Field	Subfield or refinement	Entry	Explanation and action
	BSYMODE	MSG, ACB, ACBMSG, or NONE	<p>Busy mode selector. This field specifies the call completion service that will be offered on the busy condition one of the following: MSG, ACB, ACBMSG, or None.</p> <p>If MSG is selected, refer to "Datafill for table SDSINFO tuple SDSBSY selector MSG" in this chapter. This selector is used to offer subscribers Access to Messaging service on the busy condition.</p> <p>If ACB is selected, refer to "Datafill for table SDSINFO tuple SDSBSY selector ACB" in this chapter. This selector is used to offer subscribers Enhanced Busy Call Return service on the busy condition.</p> <p>If ACBMSG is selected, refer to "Datafill for table SDSINFO tuple SDSBSY selector ACBMSG" in this chapter. This selector is used to offer subscribers a choice of either Access to Messaging service or Enhanced Busy Call Return service on the busy condition.</p> <p>If NONE is selected, no further datafill is required. This selector is used to offer subscribers no service on the busy condition.</p>

**Datafill example for table SDSINFO tuple SDSBSY selector NONE**

The following example shows sample datafill for table SDSINFO tuple SDSBSY selector NONE.

**MAP display example for table SDSINFO tuple SDSBSY selector NONE**

<p>SDSKEY SERVICE</p> <hr/>
<p>SDSBSY SDSBSY NONE</p>

**SDSINFO** (continued)**Datafill for table SDSINFO tuple SDSBSY selector MSG**

The following table lists the datafill required in table SDSINFO tuple SDSBSY selector MSG.

**Field descriptions of table SDSINFO tuple SDSBSY selector MSG**

Field	Subfield or refinement	Entry	Explanation and action
	MSGACKEY	1 to 9	Acceptance key for messaging. This field specifies the key that subscribers press to accept Access to Messaging service on the busy condition.  Field MSGACKEY pertains to Access to Messaging.
	MSGANNC	see refinements	Announcement for messaging offer. This field identifies the announcement that offers Access to Messaging service on the busy condition using the announcement's CLLI code from table CLLI.  Field MSGANNC pertains to Access to Messaging.
	STND	CLLI	This refinement specifies the CLLI for standard announcements. Datafill CLLI in table ANNMEMS.
	CUSTOM	ANNCLLI	This refinement specifies the CLLI for custom announcements. Datafill CLLI in table DRMUSERS.
		ANNID	Specifies which custom announcement to play corresponding to CLLI.
	INTERBSY	A DN with 7, 10 or up to 30 digits	Message routing DN for interLATA calls. This field specifies the message routing DN for interLATA busy calls.  Field INTERBSY pertains to Access to Messaging.
	INTRABSY	A DN with 7, 10 or up to 30 digits	Message routing DN for intraLATA calls. This field specifies the message routing DN for intraLATA busy calls.  Field INTRABSY pertains to Access to Messaging.

**SDSINFO** (continued)

**Datafill example**

The following examples show sample datafill for table SDSINFO tuple SDSBSY selector MSG.

**MAP display example for table SDSINFO tuple SDSBSY selector MSG**

```

SDSKEY  SERVICE
-----
SDSBSY  SDSBSY  MSG 1 ANNMSGBSY 6271234 18196261234
SDSBSY  SDSBSY  ACBMSG 4 CUSTOM SDSCUSTANNC 3 5155551234
7771234
    
```

**Datafill for table SDSINFO tuple SDSBSY selector ACB**

The following table lists the datafill required for table SDSINFO tuple SDSBSY selector ACB.

**Field descriptions of table SDSINFO tuple SDSBSY selector ACB (Sheet 1 of 2)**

Field	Subfield or refinement	Entry	Explanation and action
	ACBKEY	1 to 9 or NIL	Acceptance key for ACB. This field specifies the key that subscribers press to accept Enhanced Busy Call Return service.  Field AKBKEY pertains to Enhanced Busy Call Return.
	ACCEPT66	Y or N	*66 acceptance sequence. This field specifies whether *66 will be allowed as an acceptance sequence for Enhanced Busy Call Return service.  Field ACCEPT66 pertains to Enhanced Busy Call Return.
	ACBINTER	Y or N	ACB offer on interLATA calls. This field specifies whether Enhanced Busy Call Return service will be allowed on interLATA calls.  Field AKBINTER pertains to Enhanced Busy Call Return.

**SDSINFO** (continued)**Field descriptions of table SDSINFO tuple SDSBSY selector ACB (Sheet 2 of 2)**

Field	Subfield or refinement	Entry	Explanation and action
	ACBANNC	see refinements	Announcement for ACB offer. This field identifies the announcement that offers Enhanced Busy Call Return service using the announcement's CLLI code from table CLLI.  Field ACBANNC pertains to Enhanced Busy Call Return.
	STND	CLLI	This refinement specifies the CLLI for standard announcements. Datafill CLLI in table ANNMEMS.
	CUSTOM	ANNCLLI	This refinement specifies the CLLI for custom announcements. Datafill CLLI in table DRMUSERS.
		ANNID	This refinement specifies which custom announcement to play corresponding to CLLI.

**Datafill example**

The following examples show sample datafill for table SDSINFO tuple SDSBSY selector ACB.

**MAP display example for table SDSINFO tuple SDSBSY selector ACB**

```
SDSKEY SERVICE
```

---

```
SDSBSY SDSBSY ACB 2 N N STND ANN_ACB
SDSBSY SDSBSY ACB 5 Y Y STND ACBANNC
```

**SDSINFO** (continued)**Datafill for table SDSINFO tuple SDSBSY selector ACBMSG**

The following table lists the datafill required for table SDSINFO tuple SDSBSY selector ACBMSG.

**Field descriptions of table SDSINFO tuple SDSBSY selector ACBMSG (Sheet 1 of 3)**

Field	Subfield or refinement	Entry	Explanation and action
	MSGACKKEY	1 to 9	Acceptance key for messaging. This field specifies the key that subscribers press to accept Access to Messaging service on busy condition.  Field MSGACKKEY pertains to Access to Messaging.
	MSGANNC	see refinements	Announcement for messaging offer. This field identifies the announcement that offers Access to Messaging service on busy condition using the announcement's CLLI code from table CLLI.  <b>Note:</b> This field is included in selector ACBMSG to cover the case where Enhanced Busy Call Return fails to pass screening. If EBCR fails screening, only Access to Messaging service will be offered.  Field MSGANNC pertains to Access to Messaging.
	STND	CLLI	This refinement specifies the CLLI for standard announcements. Datafill CLLI in table ANNMEMS.
	CUSTOM	ANNCLLI	This refinement specifies the CLLI for custom announcements. Datafill CLLI in table DRMUSERS.
		ANNID	This refinement specifies which custom announcement to play corresponding to CLLI.
	INTERBSY	A DN with 7, 10 or up to 30 digits	Message routing DN for interLATA calls. This field specifies the message routing DN for interLATA busy calls.  Field INTERBSY pertains to Access to Messaging.



**SDSINFO** (continued)**Field descriptions of table SDSINFO tuple SDSBSY selector ACBMSG (Sheet 2 of 3)**

Field	Subfield or refinement	Entry	Explanation and action
	INTRABSY	A DN with 7, 10 or up to 30 digits	<p>Message routing DN for intraLATA calls. This field specifies the message routing DN for intraLATA busy calls.</p> <p>Field INTRABSY pertains to Access to Messaging.</p>
	ACBKEY	1 to 9 or NIL	<p>Acceptance key for ACB. This field specifies the key that subscribers should press to accept Enhanced Busy Call Return service. It should not be set to 1.</p> <p>Field ACBKEY pertains to Enhanced Busy Call Return.</p>
	ACCEPT66	Y or N	<p>*66 acceptance sequence. This field specifies whether *66 will be allowed as an acceptance sequence for Enhanced Busy Call Return service.</p> <p>Field ACCEPT66 pertains to Enhanced Busy Call Return.</p>
	ACBINTER	Y or N	<p>ACB offer on interLATA calls. This field specifies whether Enhanced Busy Call Return service will be allowed on interLATA calls.</p> <p>Field ACBINTER pertains to Enhanced Busy Call Return.</p>
	ACBANNC	see refinements	<p>Announcement for ACB offer. This field identifies the announcement that offers Enhanced Busy Call Return service using the announcement's CLLI code from table CLLI.</p> <p><b>Note:</b> This field is included in selector ACBMSG case Access to Messaging fails to pass screening. If Access to Messaging fails screening, only Enhanced Busy Call Return service will be offered.</p> <p>Field ACBANNC pertains to Enhanced Busy Call Return.</p>
	STND	CLLI	<p>This refinement specifies the CLLI for standard announcements. Datafill CLLI in table ANNMEMS.</p>

**SDSINFO** (continued)

**Field descriptions of table SDSINFO tuple SDSBSY selector ACBMSG (Sheet 3 of 3)**

Field	Subfield or refinement	Entry	Explanation and action
	CUSTOM	ANNCLLI	This refinement specifies the CLLI for custom announcements. Datafill CLLI in table DRMUSERS.
		ANNID	This refinement specifies which custom announcement to play corresponding to CLLI.
	ACBMSGAN	see refinements	Announcement for ACB and messaging offer. This field identifies the announcement that offers a choice of Enhanced Busy Call Return service or Access to Messaging service using the announcement's CLLI code from table CLLI.  Field ACBMSGAN pertains to Access to Messaging and Enhanced Busy Call Return.
	STND	CLLI	This refinement specifies the CLLI for standard announcements. Datafill CLLI in table ANNMEMS.
	CUSTOM	ANNCLLI	This refinement specifies the CLLI for custom announcements. Datafill CLLI in table DRMUSERS.
		ANNID	This refinement specifies which custom announcement to play corresponding to CLLI.

**Datafill example**

The following examples show sample datafill for table SDSINFO tuple SDSBSY selector ACBMSG.

**MAP display example for table SDSINFO tuple SDSBSY selector ACBMSG**

```

SDSKEY  SERVICE
-----
SDSBSY SDSBSY ACBMSG 1 STND ANNMSGBUSY 6271234
18196261234 2 N N STND ANN_ACB STND ANN_ACBMSG
SDSBSY SDSBSY ACBMSG 4 CUSTOM SDSCUSTANNC 3 5155551234
7771234 5 Y Y STND ACBANNC STND ACBMSGANNC
    
```

**SDSINFO** (continued)**Datafill for table SDSINFO tuple FTS**

The following table lists the datafill required in table SDSINFO tuple FTS.

**Field descriptions of table SDSINFO tuple FTS**

Field	Subfield or refinement	Entry	Explanation and action
	FTSTIMER	0 to 127	FAX-Thru Service no-answer timer. This field specifies the value (in seconds) for the timer to run before the call is routed to the FAX Messaging Platform.  <b>Note:</b> When field FTSTIMER is set to 0 (zero), the FTS call is not rerouted.
	FTSINTER	A DN with 7, 10 or up to 30 digits	FAX-Thru Service interLATA DN. This field specifies the FTS routing DN for interLATA calls.
	FTSINTRA	A DN with 7, 10 or up to 30 digits	FAX-Thru Service intraLATA DN. This field specifies the FTS routing DN for intraLATA calls.

**Datafill example**

The following example shows sample datafill for table SDSINFO tuple FTS.

**MAP display example for table SDSINFO tuple FTS**

```
SDSKEY SERVICE
```

```
FTS FTS 28 3434335 16137634556
```

**SDSINFO** (continued)**Error messages for table SDSINFO**

The following error messages apply to table SDSINFO.

**Error messages for table SDSINFO (Sheet 1 of 4)**

Error message	Explanation and action
Error: The fields SDSKEY and SERVICE must have the same value.	The entries in fields SDSKEY and SERVICE do not match.
Warning: Changing or deleting a tuple in table SDSINFO can affect SDS or FTS.	This message appears if an attempt is made to modify table SDSINFO with either the DEL or CHA command.
One or more of the SDSINFO tuples is not present. Change not allowed.	You have attempted to change the value of office parameter SDS_ENABLED in table OFCENG to Y, but at least one of tuples OFFICE, SDSOFC, SDSRNA, or SDSBSY has not been datafilled. You must datafill all of these tuples before setting the value of office parameter SDS_ENABLED in table OFCENG to Y.
Error: SDS_ENABLED is Y in table OFCENG. Disable before deleting tuple.	You cannot delete tuple OFFICE, SDSOFC, SDSRNA, or SDSBSY while office parameter SDS_ENABLED in table OFCENG is set to Y. Set SDS_ENABLED to N before deleting the tuple.
Internal error: unable to access table SDSINFO due to out of range index.	Refer to your next level of technical assistance.
Internal error: Data is invalid in table SDSINFO.	Refer to your next level of technical assistance.
Internal error: cannot allocate digilator or digilator not allocated.	Refer to your next level of technical assistance.
Internal error: cannot write to a digilator in table SDSINFO.	Refer to your next level of technical assistance.
Internal error: no digilator pool allocated for table SDSINFO.	Refer to your next level of technical assistance.
Field DNSCRN: Must be 3 or 6 digits.	Each item in field DNSCRN must be 3-digits (screens the NPA) or 6 digits (screens the NPA-NXX). Make sure each item is either 3 or 6 digits.

**SDSINFO** (continued)**Error messages for table SDSINFO (Sheet 2 of 4)**

Error message	Explanation and action
Field DNSCRN: two or more digit ranges are overlapping.	NPA screening and NPA-NXX screening overlap. Remove the redundancy.
Vector of 3 or 6 digits {0 TO 9}	This message appears when one or more non-numeric characters is entered in field DNSCRN. Reenter the field with a list of 3-digit NPAs or 6-digit NPA-NXXs
Field value must be {0-9} digit, STAR or NIL	An incorrect value has been entered in field RPTKEY or field HELP_KEY. Reenter the field with a valid entry.
Fields MSGACKEY and RPTKEY must have different values.	Use different values for fields MSGACKEY and RPTKEY.
Fields MSGACKEY and HELP_KEY must have different values.	Use different values for fields MSGACKEY and HELP_KEY.
Fields RPTKEY and HELP_KEY must have different values.	Use different values for fields RPTKEY and HELP_KEY.
Field INTERBSY: Must be 7 or more than 9 digits (up to 30 digits).	The message routing DN for interLATA busy calls must be either 7 digits or more than 9 digits (up to a maximum of 30 digits). Reenter the field with a 7-, 10-, or up to 30-digit DN.
Field INTRABSY: Must be 7 or more than 9 digits (up to 30 digits).	The message routing DN for intraLATA busy calls must be either 7 digits or more than 9 digits (up to a maximum of 30 digits). Reenter the field with a 7-, 10-, or up to 30-digit DN.
Vector of 7 or more than 9 digits {0 TO 9} up to 30 digits.	This message appears when one or more non-numeric characters is entered in one of the following fields: INTERBSY, INTERRNA, INTRABSY or INTRARNA. Reenter the field with a 7-, 10-, or up to 30-digit DN.
Fields MSGACKEY and ACBKEY must have different values in the SDSBSY tuple.	You have datafilled field BSYMODE as ACBMSG (offering the caller a choice of Enhanced Busy Call Return service or Access to Messaging service) and you have used the same key for Enhanced Busy Call Return acceptance key (ACBKEY) and the Access to Messaging acceptance key (MSGACKEY). Reenter either field MSGACKEY or field ACBKEY with a different value.

**SDSINFO** (continued)**Error messages for table SDSINFO (Sheet 3 of 4)**

Error message	Explanation and action
Fields ACBKEY and RPTKEY must have different values.	You have used the same key for the repeat key and the Enhanced Busy Call Return acceptance key (ACBKEY). Reenter either field ACBKEY or field RPTKEY with a different value.
Fields ACBKEY and HELP_KEY must have different values.	You have used the same key for the help key and the Enhanced Busy Call Return acceptance key (ACBKEY). Reenter either field ACBKEY or field HELP_KEY with a different value.
Field ACBKEY cannot take the NIL value unless the ACCEPT66 is set to Y.	You must provide either a key or a key sequence for accepting Enhanced Busy Call Return service. Either reenter field ACBKEY with a value other than NIL, reenter field ACCEPT66 with Y or do both.
Field ACCEPT66 cannot be set if the STAR is a valid help or repeat key.	Field ACCEPT66 cannot be set to Y if STAR is a valid help or repeat key since field ACCEPT66 set to Y uses the STAR key as part of *66, an acceptance sequence for Enhanced Busy Call Return service.  Either reenter field ACCEPT66 with value N or change the datafill for the help or repeat keys (fields HELP_KEY and RPTKEY) to a value other than STAR.
Fields HELP_KEY and RPTKEY cannot have STAR as a valid key if ACCEPT66 is on.	This message appears when an attempt is made to datafill STAR as either a help key or a repeat key in the case where *66 has already been datafilled as a valid acceptance sequence for Enhanced Busy Call Return service (table SDSINFO, tuple SDSBSY, field ACCEPT66 set to Y).  Set field ACCEPT66 to N or choose another key for the help or repeat key.
Warning: The RNAHELP and BSYHELP CLLIs will be deleted from table SDSINFO.	When the value of field HELP_KEY is changed from a non-nil value to NIL, the RNAHELP and BSYHELP CLLIs are deleted from the SDSINFO table.
Field value must be {1-9} digit or NIL.	Field ACBKEY must be datafilled with one digit in the range from 1 to 9 or with value NIL. Reenter this field with a valid entry.
Field INTERRNA: Must be 7 or more than 9 digits (up to 30 digits).	The message routing DN for interLATA ringing/no-answer calls must be either 7 digits or more than 9 digits (up to a maximum of 30 digits). Reenter the field with a 7-, 10-, or up to 30-digit DN.

**SDSINFO** (continued)**Error messages for table SDSINFO (Sheet 4 of 4)**

<b>Error message</b>	<b>Explanation and action</b>
Field INTRARNA: Must be 7 or more than 9 digits (up to 30 digits).	The message routing DN for intraLATA ringing/no-answer calls must be either 7 digits or more than 9 digits (up to a maximum of 30 digits). Reenter the field with a 7-, 10-, or up to 30-digit DN.
Field FTSINTER: Must be 7 or more than 9 digits (up to 30 digits).	The FAX-Thru service routing DN for interLATA calls must be either 7 digits or more than 9 digits (up to a maximum of 30 digits). Reenter the field with a 7-, 10-, or up to 30-digit DN.
Field FTSINTRA: Must be 7 or more than 9 digits (up to 30 digits).	The FAX-Thru service routing DN for intraLATA calls must be either 7 digits or more than 9 digits (up to a maximum of 30 digits). Reenter the field with a 7-, 10-, or up to 30-digit DN.
Warning: FTS SOC is ON (MSA00005). Make it IDLE for full deactivation.	This message appears when either the OFFICE or FTS tuple in table SDSINFO is deleted while the FTS SOC option is ON.

**Supplementary information**

None

**NA011**

Added field DPORIG.

**NA010**

This release has the following affects on table SDSINFO:

- added field AMSGSUBS to tuple SDSOFC
- renamed field SUBSMODE to SDSSUBS in tuple SDSOFC
- modified fields RNAHELP and BSYHELP to select the type of announcement in tuple SDSOFC
- modified field MSGANNC to prompt for the type of announcement in tuple SDSRNA
- modified fields MSGANNC, ACBANNC, and ACBMSGAN to prompt for the type of announcement in tuple SDSBSY

**NA007**

New fields added to tuple OFFICE: CFW, CONF, HNTGRP, and REJECTMT.  
 New field added to tuple SDSOFC: EXDIGCOL. Two selectors added to tuple

**SDSINFO** (end)

---

SDSRNA: MSG and NONE. Four selectors added to tuple SDSBSY: MSG, ACB, ACBMSG, and NONE. New error messages added.

**NA006**

FTS tuple added. Existing OFFICE tuple split into tuples OFFICE, SDSOFC, SDSRNA, SDSBSY. New error messages added.

**NA005**

Added fields RPTKEY, HELPKEY, RNAHELP, and BSYHELP.

**NA004**

This table was created.



---

**SEILINKS**

---

**Table name**

Service Evaluation System Table

**Functional description**

The No. 2 Service Evaluation System (No. 2 SES) is an AT&T system that evaluates telecommunications performance by determining how efficiently the telephone network processes calls. Through the No. 2 SES, operating companies evaluate service by randomly sampling calls and determining if these calls are completing properly.

The DMS/No. 2 SES interface, which makes possible this type of service evaluation for calls made through a DMS, supports both incoming trunk service evaluation (ITSE) and dial line service evaluation (DLSE). Depending on the type of office being evaluated (local or toll, for example) service evaluation can be performed for ITSE call types, DLSE call types, or both.

This analog DLSE trunk on a trunk module (TM) with eight-wire circuits (TM8) requires a DS1SIG card with a digital TM. This configuration is provided on the NT2X82AA card (Two-wire incoming, loop, reverse battery trunk circuit card).

Table SEILINKS defines the type and location of the service evaluation interface (SEI) configured in a DMS office. An SEI can be configured for both ITSE and DLSE call types. No more than two interfaces can be configured in an office, one for ITSE and one for DLSE. As a result, table SEILINKS can be datafilled to include a maximum of two tuples, one for each type of interface.

For related information, refer to table MPC.

**Datafill sequence and implications**

The following tables must be datafilled before table SEILINKS.

- MPC
- MPCLINK
- all trunk inventory tables

Datafill for subfields PMTYPE, PMNO, PMCKTNO, and PMCCKTTS is identical to datafill in table TRKMEM.

The voice link datafilled for service evaluation must not be datafilled in table TRKMEM or table TRKGRP.

**SEILINKS** (continued)

Table SEILINKS is initially datafilled by operating company personnel at installation.

**Table size**

Memory for table SEILINKS is allocated for up to 2 entries. One entry is allocated for each type of service evaluation possible.

**Datafill**

The following table lists datafill for table SEILINKS.

**Field descriptions (Sheet 1 of 3)**

Field	Subfield or refinement	Entry	Explanation and action
KEY		ITSE or DLSE	<p><i>Service evaluation identifier</i></p> <p>This field specifies the type of service evaluation interface (SEI) configured for service evaluation.</p> <p>Enter either ITSE (incoming trunk service evaluation) or DLSE (dial line service evaluation). Both ITSE and DLSE interfaces can be supported in an office, but no more than two tuples can be present in this table.</p>
DATALINK		see subfields	<p><i>Service evaluation interface datalink identification</i></p> <p>This field specifies the datalink to be used with an associated SEI and consists of subfields MPCNO, LINKNO, and CHANNO.</p>
	MPCNO	0 to 255	<p><i>Multiprotocol controller number</i></p> <p>Enter the multiprotocol controller (MPC) number to be associated with the SEI datalink as previously datafilled in table MPCLINK.</p>
	LINKNO	2 or 3	<p><i>Multiprotocol controller link number</i></p> <p>Enter theMPC link number associated with the SEI datalink as previously datafilled in table MPCLINK. The link number must be 2 or 3.</p>

**SEILINKS** (continued)

## Field descriptions (Sheet 2 of 3)

Field	Subfield or refinement	Entry	Explanation and action
VOICELNK	CHANNO	2 or 3	<i>Multiprotocol controllerchannel number</i>  Enter the MPC channel number to be associated with the SEI datalink as previously datafilled in table MPCLINK. This number is predefined by the No. 2 Service Evaluation System (SES).  Enter 1 for DLSE or 2 for ITSE. No other channel number entries are accepted.
		see subfields	<i>Voice link</i>  This field consists of subfields PMTYPE, PMNO, PMCKTNO, and PMCKTTS..
	PMTYPE	see below	<i>Peripheral module type</i>  Enter the trunk circuit peripheral module (PM) type dedicated as the voice link for service evaluation by the No. 2 (SES) as described below.
		DCM	DCM (digital carrier module) and datafill refinements DCMNO, DCMCKTNO, and DCMCKTTS.
		DTC	DTC (digital trunk controller) and datafill refinements DTCNO, DTCKTNO, and DTCKTTS.
		IDTC	IDTC (international digital trunk controller) and datafill refinements DEQNO, DEQCKTNO, and DEQCKTTS .
		ILTC	ILTC (international line trunk controller) and datafill refinements DEQNO, DEQCKTNO, and DEQCKTTS.
		LTC	LTC (line trunk controller) and datafill refinements LTCNO, LTCKTNO, and LTCKTTS.
		PDTC	PDTC (PCM30 digital trunk controller) and datafill refinements DEQNO, DEQCKTNO, and DEQCKTTS.

**SEILINKS** (continued)**Field descriptions (Sheet 3 of 3)**

Field	Subfield or refinement	Entry	Explanation and action
		RCC	RCC (remote cluster controller) and datafill refinements RCCNO, RCCCKTNO, and RCCCKTTS.
		RCC2	RCC2 (remote cluster controller 2) and datafill refinements RCC2NO, RCC2CKTNO, and RCC2CKTTS.
		RCCI	RCCI (ISDN remote cluster controller) and datafill refinements RCCINO, RCCICKTNO, and RCCICKTTS.
		RCO2	RCO2 (remote cluster controller 2 offshore) and datafill refinements RCO2NO, RCO2CKTNO, and RCO2CKTTS.
		RMSC	RMSC (remote mobile switching centre) and datafill refinements RMSCNO, RMSCCKTNO, and RMCKTTS.
		SRCC	SRCC (SONET remote cluster controller) and datafill refinements SRCCNO, SRCCCKTNO, and SRCCCKTTS.
		T8A	T8A (trunk module with eight-wire circuits and a metallic test access bus) and datafill refinements TMNO and TMCKTNO.
		TM2	TM2 (trunk module with two-wire circuits) and datafill refinements TMNO and TMCKTNO.
		TM4	TM4 (trunk module with four-wire circuits) and datafill refinements TMNO and TMCKTNO.
		TM8	TM8 (trunk module with eight-wire circuits) and datafill refinements TMNO and TMCKTNO .
		NIL_PM-TYPE	Any entry outside the range indicated for this field is invalid.

**Note:** Datafill for subfields MPCNO, LINKNO, and CHANNO must match that provided in table MPCLINK. In addition, all subfield entries must be entered at the DATALINK prompt. Subfield entries cannot be entered individually.

**SEILINKS** (continued)**PMTYPE = DCM**

If the entry in field PMTYPE is DCM, datafill refinements DCMNO, DCMCKTNO, and DCMCCKTTS as described in the next table.

**Field descriptions for conditional datafill**

Field	Subfield or refinement	Entry	Explanation and action
	DCMNO	0 to 511	<i>Digital carrier module number</i> Enter the common language location identifier (CLLI) number of the trunk dedicated as the voice link for service evaluation by the No. 2 SES.
	DCMCKTNO	0 to 4	<i>Digital carrier module circuit number</i> Enter the number of the circuit dedicated as the voice link for service evaluation by the No. 2 SES.
	DCMCCKTTS	1 to 24	<i>Digital carrier module circuit time slot</i> Enter the number of the digital trunk circuit time slot dedicated as the voice link for service evaluation by the No. 2 SES. Go to field CARDCODE.

**PMTYPE = DTC**

If the entry in field PMTYPE is DTC, datafill refinements DTCNO, DTCCCKTNO, and DTCCCKTTS as described in the following table.

**Field descriptions for conditional datafill (Sheet 1 of 2)**

Field	Subfield or refinement	Entry	Explanation and action
	DTCNO	0 to 511	<i>Digital trunk controller number</i> Enter the common language location identifier (CLLI) number of the trunk dedicated as the voice link for service evaluation by the No. 2 SES.

**SEILINKS** (continued)**Field descriptions for conditional datafill (Sheet 2 of 2)**

Field	Subfield or refinement	Entry	Explanation and action
	DTCKTNO	0 to 19	<i>Digital trunk controller circuit number</i> Enter the number of the circuit dedicated as the voice link for service evaluation by the No. 2 SES.
	DTCCCKTTS	1 to 24	<i>Digital trunk controller circuit time slot</i> Enter the number of the digital trunk circuit time slot dedicated as the voice link for service evaluation by the No. 2 SES. Go to field CARDCODE.

**PMTYPE = ILTC, IDTC, or PDTC**

If the entry in field PMTYPE is ILTC, IDTC, or PDTC, datafill refinements DEQNO, DEQCKTNO, and DEQCCKTTS as described in the following table.

**Field descriptions for conditional datafill**

Field	Subfield or refinement	Entry	Explanation and action
	DEQNO	0 to 511	<i>Equipment number</i> Enter the common language location identifier (CLLI) number of the trunk dedicated as the voice link for service evaluation by the No. 2 SES.
	DEQCKTNO	0 to 19	<i>Equipment circuit number</i> Enter the number of the circuit dedicated as the voice link for service evaluation by the No. 2 SES.
	DEQCCKTTS	1 to 31	<i>Equipment circuit time slot</i> Enter the number of the digital trunk circuit time slot dedicated as the voice link for service evaluation by the No. 2 SES. Go to field CARDCODE.

**SEILINKS** (continued)**PMTYPE = LTC**

If the entry in field PMTYPE is LTC, datafill refinements LTCNO, LTCCKTNO, and LTCCCKTTS as described in the following table.

**Field descriptions for conditional datafill**

Field	Subfield or refinement	Entry	Explanation and action
	LTCNO	0 to 511	<i>Line trunk controller number</i> Enter the common language location identifier (CLLI) number of the trunk dedicated as the voice link for service evaluation by the No. 2 SES.
	LTCCKTNO	0 to 19	<i>Equipment circuit number</i> Enter the number of the circuit dedicated as the voice link for service evaluation by the No. 2 SES.
	LTCCCKTTS	1 to 24	<i>Equipment circuit time slot</i> Enter the number of the digital trunk circuit time slot dedicated as the voice link for service evaluation by the No. 2 SES. Go to field CARDCODE.

**PMTYPE = RCC**

If the entry in field PMTYPE is RCC, datafill refinements RCCNO, RCCCKTNO, and RCCCKTTS as described in the following table.

**Field descriptions for conditional datafill (Sheet 1 of 2)**

Field	Subfield or refinement	Entry	Explanation and action
	RCCNO	0 to 511	<i>Remote cluster controller number</i> Enter the common language location identifier (CLLI) number of the trunk dedicated as the voice link for service evaluation by the No. 2 SES.

**SEILINKS** (continued)**Field descriptions for conditional datafill (Sheet 2 of 2)**

Field	Subfield or refinement	Entry	Explanation and action
	RCCCKTNO	0 to 19	<i>Remote cluster controller circuit number</i> Enter the number of the circuit dedicated as the voice link for service evaluation by the No. 2 SES.
	RCCCCKTTS	1 to 24	<i>Remote cluster controller circuit time slot</i> Enter the number of the digital trunk circuit time slot dedicated as the voice link for service evaluation by the No. 2 SES. Go to field CARDCODE.

**PMTYPE = RCC2**

If the entry in field PMTYPE is RCC2, datafill refinements RCC2NO, RCC2CKTNO, and RCC2CCKTTS as described in the following table.

**Field descriptions for conditional datafill**

Field	Subfield or refinement	Entry	Explanation and action
	RCC2NO	0 to 511	<i>Remote cluster controller 2 number</i> Enter the common language location identifier (CLLI) number of the trunk dedicated as the voice link for service evaluation by the No. 2 SES.
	RCC2CKTNO	0 to 47	<i>Remote cluster controller 2 circuit number</i> Enter the number of the circuit dedicated as the voice link for service evaluation by the No. 2 SES.
	RCC2CCKTTS	1 to 31	<i>Remote cluster controller circuit time slot</i> Enter the number of the digital trunk circuit time slot dedicated as the voice link for service evaluation by the No. 2 SES. Go to field CARDCODE.



**SEILINKS** (continued)**PMTYPE = RCCI**

If the entry in field PMTYPE is RCCI, datafill refinements RCCINO, RCCICKTNO, and RCCICCKTTS as described in the following table.

**Field descriptions for conditional datafill**

<b>Field</b>	<b>Subfield or refinement</b>	<b>Entry</b>	<b>Explanation and action</b>
	RCCINO	0 to 511	<i>ISDN remote cluster controller number</i> Enter the common language location identifier (CLLI) number of the trunk dedicated as the voice link for service evaluation by the No. 2 SES.
	RCCICKTNO	0 to 19	<i>ISDN remote cluster controller circuit number</i> Enter the number of the circuit dedicated as the voice link for service evaluation by the No. 2 SES.
	RCCICCKTTS	1 to 24	<i>ISDN remote cluster controller circuit time slot</i> Enter the number of the digital trunk circuit time slot dedicated as the voice link for service evaluation by the No. 2 SES. Go to field CARDCODE.

**SEILINKS** (continued)**PMTYPE = RCO2**

If the entry in field PMTYPE is RCO2, datafill refinements RCO2NO, RCO2CKTNO, and RCO2CCKTTS as described in the following table.

**Field descriptions for conditional datafill**

<b>Field</b>	<b>Subfield or refinement</b>	<b>Entry</b>	<b>Explanation and action</b>
	RCO2NO	0 to 511	<i>Remote cluster controller 2 offshore number</i>  Enter the common language location identifier (CLLI) number of the trunk dedicated as the voice link for service evaluation by the No. 2 SES.
	RCO2CKTNO	0 to 47	<i>Remote cluster controller 2 offshore circuit number</i>  Enter the number of the circuit dedicated as the voice link for service evaluation by the No. 2 SES.
	RCO2CCKTTS	1 to 31	<i>Remote cluster controller 2 offshore circuit time slot</i>  Enter the number of the digital trunk circuit time slot dedicated as the voice link for service evaluation by the No. 2 SES.  Go to field CARDCODE.

**SEILINKS** (continued)**PMTYPE = RMSC**

If the entry in field PMTYPE is RMSC, datafill refinements RMSCNO, RMSCCKTNO, and RMSCCKTTS as described in the following table.

**Field descriptions for conditional datafill**

<b>Field</b>	<b>Subfield or refinement</b>	<b>Entry</b>	<b>Explanation and action</b>
	RMSCNO	0 to 511	<i>Remote mobile switching centre number</i>  Enter the common language location identifier (CLLI) number of the trunk dedicated as the voice link for service evaluation by the No. 2 SES.
	RMSCCKTNO	0 to 47	<i>Remote mobile switching center circuit number</i>  Enter the number of the circuit dedicated as the voice link for service evaluation by the No. 2 SES.
	RMSCC-CKTTS	1 to 31	<i>Remote mobile switching center circuit time slot</i>  Enter the number of the digital trunk circuit time slot dedicated as the voice link for service evaluation by the No. 2 SES.  Go to field CARDCODE.

**SEILINKS** (continued)**PMTYPE = SRCC**

If the entry in field PMTYPE is SRCC, datafill refinements SRCCNO, SRCCCKTNO, and SRCCCCKTTS as described in the following table.

**Field descriptions for conditional datafill**

<b>Field</b>	<b>Subfield or refinement</b>	<b>Entry</b>	<b>Explanation and action</b>
	SRCCNO	0 to 511	<i>SONET remote cluster controller number</i>  Enter the common language location identifier (CLLI) number of the trunk dedicated as the voice link for service evaluation by the No. 2 SES.
	SRCCCKTNO	0 to 47	<i>SONET remote cluster controller circuit number</i>  Enter the number of the circuit dedicated as the voice link for service evaluation by the No. 2 SES.
	SRCCCCKTTS	1 to 31	<i>SONET remote cluster controller circuit time slot</i>  Enter the number of the digital trunk circuit time slot dedicated as the voice link for service evaluation by the No. 2 SES.  Go to field CARDCODE.

**SEILINKS** (continued)**PMTYPE = T8A, TM2, TM4, or TM8**

If the entry in field PMTYPE is T8A, TM2, TM4, or TM8, datafill refinements TMNO, TMCKTNO, and TMCCKTTS as described in the following table.

**Field descriptions for conditional datafill**

<b>Field</b>	<b>Subfield or refinement</b>	<b>Entry</b>	<b>Explanation and action</b>
	TMNO	0 to 511	<i>Trunk module number</i>  Enter the common language location identifier (CLLI) number of the trunk dedicated as the voice link for service evaluation by the No. 2 SES.
	TMCKTNO	0 to 47	<i>Trunk module circuit number</i>  Enter the number of the circuit dedicated as the voice link for service evaluation by the No. 2 SES.
	TMCCKTTS	1 to 31	<i>Trunk module circuit time slot</i>  Enter the number of the digital trunk circuit time slot dedicated as the voice link for service evaluation by the No. 2 SES.  Go to field CARDCODE.

**SEILINKS** (continued)**PMTYPE = all entries**

For all entries in field PMTYPE, datafill fields CARDCODE and STATUS as described in the following table.

**Field descriptions for conditional datafill**

Field	Subfield or refinement	Entry	Explanation and action
CARDCODE		alphanumeric (up to 8 characters)	<i>Product equipment code</i>  Enter the product engineering code (PEC) of the card defined as the SEI voice link trunk circuit (NT2X82AA or DS1SIG, for example). The NT2X82AA is for a digital TM only.
STATUS		ENABLED or DISABLED	<i>Service evaluation interface status</i>  This field defines the operating status of the SEI. Enter ENABLED to allow the SEI to begin active processing. Otherwise, enter DISABLED.  <b>Note 1:</b> Changes to field STATUS take place immediately. Enabling an SEI initiates SEI processing, even if associated voice and data links are not in service. The SEI can be enabled independently of these links. If field STATUS is set to DISABLED, SEI processing and call evaluation is stopped.  <b>Note 2:</b> Datalink and voicelink datafill can be changed if the associated SEI is active, however, the link being changed must first be taken offline.

**Datafill example**

An example of datafill for table SEILINKS is shown below.

In the first tuple, field KEY defines ITSE as the SEI. Subfield MPCNO specifies MPC shelf 8. Subfield LINKNO defines the MPC link 2. Subfield CHANNO defines channel 2 for the ITSE datalink.

Field PMTYPE defines TM8 for use with ITSE. Field PMNO is 0 (zero). Field PMCKTNO defines a trunk module circuit number of 21. Field CARDCODE defines a PEC of 2X82AA for the ITSE interface. Field STATUS indicates that ITSE is enabled and ready for call evaluation.

---

**SEILINKS** (end)

---

The second tuple in this example defines similar values for DLSE. The DLSE interface is **DISABLED** in this example, and a digital card is defined for the voice link.

**MAP display example for table SEILINKS**

KEY	DATALINK	PMTYPE	CARDCODE	STATUS
ITSE	8 2 2	TM8 0 21	2X82AA	ENABLED

**Table history**  
**BCS36**

Entries for field **PMTYPE** were validated. Refinements for entries in field **PMTYPE** were added.

---

## SELDEFS

---

**ATTENTION**

This table applies to new or modified content for SN07(DMS) that is valid through the current release.

## SELDEFS

### Datafill sequence and implications

Datafill follows table SETDEFS during a software delivery process. Some of the tuples are generated at IPL time and cannot be altered. All the other tuples are defined by the site via the Post Release Software Manager (PRSM) seldef command and are preserved over a software delivery process.

### Table size

The table may contain up to 256 entries.

### Datafill

Datafilling is done via PRSM.

### Fields and subfields for table SELDEFS

Field	Subfield or refinement
DEFNAME	SELDEFS_KEY
SELDEF	PRSM_DEFINITION_VECTOR

### Table history

#### SN07(DMS)

New table SELDEFS created as part of activity Q01083765.



## **SERVICE**

---

### **Table name**

Automatic Calling Card Service Table

### **Functional description**

Table SERVICE is used by international translation to route to the Automatic Calling Card Service (ACCS) system. SERVICE is called from translation using a "T" selector and data in the table is used to drive the ACCS processor's collection of the calling card number and the called number as well as the translation of the called number for outpulsing. ACCS is a credit card calling service that provides customers with the convenience of making calls and automatically having them charged to an account independent of the calling line.

### **Datafill sequence and implications**

There is no requirement to datafill other tables prior to table SERVICE.

### **Table size**

0 to 999 tuples

**SERVICE** (continued)**Datafill**

The following table lists datafill for table SERVICE.

**Field descriptions (Sheet 1 of 2)**

Field	Subfield or refinement	Entry	Explanation and action
INDEX		1 to 99	<i>T selector index</i> Enter the table key used as the "T" selector index from translations.
ORIG		CCFIRST CLDFIRST CCONLY	<i>ACCS origination</i> Enter the type of ACCS origination used to drive the ACCS collection of digits. Enter CCFIRST when the calling card should be collected before the called number. Enter CLDFIRST when the called number should be collected before the calling card number. Enter CCONLY when the called number is known through signalling and only the calling card number needs to be collected. <b>Note:</b> CCONLY is not supported at this time.
XLATION		see subfields	<i>Translation</i> This field is composed of subfields XLADSEL, XLASYS, and XLANAME.
	XLADSEL	UNIV	<i>Translation selector</i> Enter the type of translation system used to validate the called numbers entered by the customer and route these called numbers. <b>Note:</b> Only UNIV is supported at this time.

**SERVICE** (end)

**Field descriptions (Sheet 2 of 2)**

Field	Subfield or refinement	Entry	Explanation and action
	XLASYS	AC, AM, CT, DN, FA, FT, OFC, PX, IBS, NSC, or NIL	<i>Translation system</i> Enter the translation system to use, and complete subfield XLANAME (the instance of the translation system).
	XLANAME	alphanumeric (1 to 8 characters)	<i>Translation name</i> Enter the translation name of the table instance within the XLASYS to which the call is to be routed.

**Datafill example**

The following example shows sample datafill for table SERVICE.

The entry consists of a "T" selector index of 19, an ACCS origination of CCFIRST indicating the calling card must be collected before the called number, a universal (UNIV) translation system and the type of translation to be done.

**MAP display example for table SERVICE**

INDEX	ORIG	XLATION		
19	CCFIRST	UNIV	PX	ACCBXLA

---

**SERVICES**

---

**Table name**

TOPS Services Table

**Functional description**

Table SERVICES identifies the protocol, data link type, and data base listing identifier for toll and assistance (TASERV), directory assistance (DASERV), and intercept services (INTCSERV).

In NA006, this table is changed to provide database information by instance (defined in the following paragraph) instead of by application. This change is to extend the database access from one to numerous DA databases. Since it is recommended to have at least two datalinks per database, a maximum of 8 DA databases can be defined. There are 16 available datalinks per application for DA and INTC. For more information, refer to functionality Multiple DA System I, OSDA00001.

An instance is a subset of an application. For example, TOPSVR1 is an application which may be assigned to the DA or INTC service. TOPSVR1 0, TOPSVR1 1, TOPSVR1 2, ...' are instances of the TOPSVR1 application. The instances may be defined to different links and therefore to different databases, but they are all still DA/INTC applications.

Table VROPT contains the following voice response related parameters:

- BCS\_ID
- PRIMARY\_LANGUAGE
- SECONDARY\_LANGUAGE
- LOGINOUT\_TIMEOUT
- AUTO\_INT\_TIMEOUT
- FLOAT\_INT\_TIMEOUT
- BEGIN\_ANN\_TIMEOUT
- POST\_ANN\_TIMEOUT
- MAXIMUM\_DA\_RECALLS
- MAXIMUM\_INT\_RECALLS
- DACC\_BILL\_TO\_THIRD
- DA\_ANN\_FAIL\_RECALLS\_ALLOWED

**SERVICES** (continued)

- INT\_ANN\_FAIL\_RECALLS\_ALLOWED
- INT\_CUT\_THROUGH\_ALLOWED



**CAUTION**

**An improper field VERSION value causes failures.**  
 The field VERSION value must support the D1 and DA protocol versions; otherwise, database queries fail. Refer to field VERSION for more information.

**Datafill sequence and implications**

Table MPCLSET must be datafilled with the application instance before it can be added to table SERVICES.

**Table size**

0 to 32 tuples

**Datafill**

The following table lists datafill for table SERVICES.

**Field descriptions (Sheet 1 of 4)**

Field	Subfield or refinement	Entry	Explanation and action
INDEX		see subfields	Index. This is the key into the table. This field consists of subfields APPLICATION and SETNO.
	APPLICATION	TOPSVR1, TOPSVR2, or STUB	Application. Applications TOPSVR1 and TOPSVR2 must be previously defined in table MPCLSET.  Application STUB is used primarily in a lab environment, but is sometimes used in configurations that do not have DMS-DAS links. STUB instances are used as the database instance when DASIM is being used. There can be up to 16 STUB instances. STUBs do not require datafill in table MPCLSET.

**SERVICES** (continued)

## Field descriptions (Sheet 2 of 4)

Field	Subfield or refinement	Entry	Explanation and action
PROTOCOL	SETNO	0 to 15	Link set number. This entry must be previously defined in table MPCLSET.
		CCI, IBM, or LOCKHEED, NILPROTOCOL	Base service protocol. Enter the protocol for the base service. If the entry is CCI, datafill subfield ADASPLUS.
	ADASPLUS	Y or N	Automated Directory Assistance System Plus. Datafill this field if PROTOCOL = CCI. Enter Y if the database can provide ADASPLUS service and receive ADASPLUS traffic. Enter N if ADASPLUS is not offered on the database and ADASPLUS eligible calls for that database are treated as regular DA calls. For INTC services, this field has no effect on INTC calls. For further information on ADASPLUS, refer to functionality DA Automation I/F, OSDA0006.
LSDBID		0000 to 9999	Listing services data base identifier. Datafill this field if field BASESERV = DASERV or INTCSERV. An LSDBID is assigned per database instance. This ID is sent in AMA records and processed by the downstream AMA processors.
SWITCHID		0 to 99 (CCI) or 0 to 15 (IBM)	Switch identification. A switch ID is assigned per database instance. This ID number is sent to the database to identify the switch. Unique switch IDs are required since some databases may service multiple switches. Currently, IBM only supports the range 0 to 15.

**SERVICES** (continued)

## Field descriptions (Sheet 3 of 4)

Field	Subfield or refinement	Entry	Explanation and action
VERSION		1 to 1000	<p>Version.</p> <p>This field specifies the protocol version on a link set basis. This field allows an upgrade of the respective DAS to new versions of the protocol independently of a switch software upgrade.</p> <p>For additional information, refer to the error messages that follow and functionality Branding via SPID, ENSV0017.</p> <p><i>CAUTION:</i>The values must be compatible with the D1 and DA protocol versions; otherwise, database queries fail. Refer to the tables that follow these field descriptions.</p> <p>The valid values are as follows:</p> <ul style="list-style-type: none"> <li>• 1: The only allowed value for IBM protocol.</li> <li>• 2: An early TOPS03 development value for CCI protocol.</li> </ul> <p>Value 2 was developed for Cellular ACACC (OSDA0005) and ADAS+ (OSDA0006). So, these features must be present in the switch and turned on by SOC to use this version.</p> <p>If changing from value 1 to 2, in table ADACCOPT field BILTYPES do not use value OPERBIL for call completion since it is not supported by the DAS. This restriction is not present in later VERSION values.</p>

**SERVICES** (continued)

## Field descriptions (Sheet 4 of 4)

Field	Subfield or refinement	Entry	Explanation and action
			<p>The valid values are as follows (continued):</p> <ul style="list-style-type: none"> <li>3: Available for CCI protocol in TOPS03. For ADASPLUS, field VERSION must be 3 or higher.</li> </ul> <p>Value 3 has more ADAS+ (OSDA0006) components. So, this feature must be present in the switch and turned on by SOC to use this version.</p> <ul style="list-style-type: none"> <li>4: Available for CCI protocol in TOPS07. This value provides the AO SPID.</li> <li>5: Available for CCI protocol in TOPS09. This value provides more AO SPID components and AUTOLANG.</li> </ul>

As of release TOPS11, only the latest four versions of the DA protocol are supported. The table that follows shows the supported DA protocol versions for each TOPS software release.

**Supported DA protocol versions**

TOPS release	Supported DA protocol versions (field VERSION)
TOPS11	2-5
TOPS 09-TOPS10	1-5
TOPS07-TOPS08	1-4
TOPS03-TOPS06	1-3



## SERVICES (continued)

The table that follows shows the supported DAS D1 protocol versions for the DMS switch loads and DA protocol versions (field VERSION).

### Supported D1 protocol versions

Release, field VERSION	D1 1.02	D1 1.03	D1 1.04	D1 1.04.1	D1 1.05.1	D1 1.05.2	D1 2.01	D1 2.01.1
TOPS03, version 2	X	X	X	X	X	X	X	X
TOPS04-TOPS6, version 3		X	X	X	X	X	X	X
TOPS07-TOPS08, version 4						X	X	X
TOPS09-TOP11, version 5								X
<b>Note:</b> X means the D1 release supports the indicated DMS load								

### Datafill example

The following example shows sample datafill for table SERVICES.

#### MAP display example for table SERVICES

DBINST	PROTOCOL	LSDBID	SWITCHID	VERSION
TOPSVR1 0	CCI Y	1234	5	5
TOPSVR1 1	IBM	5678	8	1
TOPSVR1 3	CCI N	3453	54	1
TOPSVR2 0	CCI N	2138	98	1
STUB 0	CCI Y	1234	5	1

**SERVICES** (continued)**Error and warning messages for table SERVICES**

The following error and warning messages apply to table SERVICES.

**Error and warning messages for table SERVICES**

Error or warning message	Explanation and action
The maximum VERSION supported for CCI is 5.	This error message appears if an attempt is made to enter a VERSION greater than 5 using the CCI protocol.
The maximum VERSION supported for IBM is 1.	This error message appears if an attempt is made to enter a VERSION greater than 1 using the IBM protocol.
VERSION must be 3 or greater for ADASPLUS to take effect.	This warning message appears when a protocol version less than 3 is entered for the CCI protocol with ADASPLUS set to Y. This message indicates that ADAS+ does not function on the link set unless the VERSION is 3 or greater even if ADASPLUS is set to Y. Note that the ADASPLUS_ENABLE parameter in TOPSPARM must also be set to Y and SOC option OSDA0006 must be ON for ADAS+ to work.

**Table history****TOPS09**

Field VERSION value 5 is supported.

**TOPS07**

Field VERSION is added by feature AF6711 in functionality Branding via SPID, ENSV0017. Field VERSION supports values 1-4.

**TOPS06**

This table was changed to provide database information by instance instead of by application by feature AN1844 in functionality Multiple DA System I, OSDA00001. Following are the changes:

- The key index is changed from an integer to a database instance.
- Field SWITCHID is added, which was moved from table VROPT.
- Subfield ADASPLUS is added for CCI databases for ADASPLUS service.
- Field BASESERV is removed since this information is provided in tables TQMSSERV (for QMS) and VROPT (for ACD).

## **SERVICES** (end)

---

- Alarms are moved to table VROPT.
- The datalink field is no longer needed since MPC1 and MPC2 correspond to TOPSVR1 and TOPSVR2, respectively. Since the instances are now the index to the table, it is no longer necessary to specify the datalink.

### **Supplementary information**

None

---

## SERVINFO

---

### Table name

Intelligent Network Service Information Table

### Functional description

Table SERVINFO contains information related to an international intelligent network (IN) service. Services are identified by the service index, which is the key to table SERVINFO. This gives the customer the ability to tailor and adapt IN services on a per-customer, per-service basis. (Service Profiling)

The role of table SERVINFO is to:

- determine the parameter content of the InitialDP operation
- determine whether a one-way or two-way speech path for in-band interaction between the calling party and a specialized resource function (SRF) is established
- determine whether to wait for the full Called Party Number before sending an InitialDP
- determine whether or not to use multiple PromptAndCollectUserInformation (P&CUI) operations to collect a single stream of incoming inband digits.
- determine how many (if any) digits are to be stripped from the called party number (CDPA)
- determine which AMA extension module (if any) is attached to the AMA billing record (28, 40, 199, 611, or 612)
- determine if post-Connect, post-EstablishTemporaryConnection (ETC) or post-Continue translations must start from one of the following locations:
  - a specified universal translations system
  - table IBNXLA
- determine whether table INNCOS is used to identify the point of re-entry into translations, or whether the network class of service (NCOS) is changed for the Capability Set 1 Refined (CS-1R) call
- indicate the type and format of data received by the DMS SSP in the BillingChargingCharacteristics parameter of the FurnishChargingInformation (FCI) operation
- control the automatic disarming of implicitly undetectable event detection points (EDP)

- optionally apply charging to backwards progress messages sent to previous exchanges
- determine whether to correlate multiple billing records closed during the progress of a call sequence arising from a single operation
- optionally specify CS-1R handling of the Continue and/or ContinueWithArgument operations
- optionally allows the use of UK ISUP proprietary INAP extensions on a per-service basis
- determine if support for interaction of IN triggering is supported with Network CCBS and Nodal CCBS

### **Datafill sequence and implications**

Table SERVINFO must be datafilled before the SERVIDX option is datafilled in table TRIGDIG.

### **Table size**

0 to 1024 tuples

Table SERVINFO table size is dynamically allocated.

### **Datafill**

The following table lists datafill for table SERVINFO.

**ATTENTION**

In subfield RESPONSE\_INFO, you can remove a translator from the translations system due to deletion requests from the related xxHEAD universal translations table. Make sure that you remove translators from table SERVINFO before you remove the same translators from the universal translations tables. The removal of these translators at the wrong time can cause invalid call results related to point of re-entry control.

## Field descriptions

Field	Subfield	Entry	Explanation and action
SERVIDX		0 to 9999	SERVINFO index. This field indicates an IN service on the DMS SSP switch. This field is the key from tables TRIGINFO and TRIGDIG.  Enter a key number to uniquely identify the IN service.
OPTION		INITDP_PARMS, BILL_INFO, DIGIT_COLLECTION_INFO, SRF_INFO, RESPONSE_INFO, EDPS_INFO, BCI_INFO, TCAP_INFO, FI, CS1R, INITDP_UK_EXTENSIONS, CCBS	These are the main categories from which various per-service options and controls reside.
	INITDP_PARMS	see subfield INITDP_PARM_INFO	This entry controls what information is included as parameters to the InitialDP operation.

**Field descriptions**

Field	Subfield	Entry	Explanation and action
	INITDP_PARM_ INFO	SERVKEY, CDPA, CLI, CPC, BUS_GROUP, BC, EVENT_TYPE, OCN, RDN, DD, RD_INFO, FWD_CI	<p>Enter SERVKEY to include the service key.</p> <p>Enter CDPA to include the Called Party Address.</p> <p>Enter CLI to include the Calling Line Identity (Calling Party Number).</p> <p>Enter CPC to include the Calling Party Category.</p> <p>Enter BUS_GROUP to include the BusinessGroupID and Network Class of Service information.</p> <p>Enter BC to include the bearer Capability parameter (if it was encoded).</p> <p>Enter EVENT_TYPE to include the eventTypeBCSM parameter.</p> <p>Enter OCN to include the originalCalledPartyID parameter (The DN originally dialed by the calling party).</p> <p>Enter RDN to include the redirectingPartyID parameter (The DN the call was redirected to).</p> <p>Enter DD to include the original untranslated dialed digits in the dialedDigits parameter. Enter RD_INFO to map the incoming ISUP IAM redirection information parameter into the InitialDP.</p> <p>Enter FWD_CI to make the ForwardCallIndicator parameter available in the InitialDP operation. When available, EINTRACE, a diagnostic tracing tool, will display the FWD_CI value.</p>

## Field descriptions

Field	Subfield	Entry	Explanation and action
			Enter RD_INFO to control the sending of the redirection information parameter of the InitialDP operation. This is mapped from the relevant call setup messages received. If RD_INFO is datafilled and is not obtainable, the redirection information will be sent and set to NO_REDIRECTION with the rest of the fields set to zero.
	BILL_INFO	see subfield BILLING_INFO_OPTION	This option controls options relating to the billing of IN services.
	BILLING_INFO_OPTION	AMA_OPT, FCI_OPT	Enter AMA_OPT to further specify IN-related billing options.  Enter FCI_OPT to further specify what the format of the FCIBillingChargingCharacteristics parameter contained in the FCI operation received will be, and stored in AMA module 199. This allows FCI compatibility with non-Nortel SCPs.
	AMA_INFO_OPTION (Subfield of AMA_OPT)	DIALED_DIGITS_INFO, AMA_XLA_OPT, CORRELATION_ID	Enter DIALED_DIGITS_INFO to further specify which, if any, AMA extension module is appended to the base billing record by the SSP to record the original dialled digits (translated in the case of calls triggering at TDP-3)



**Field descriptions**

Field	Subfield	Entry	Explanation and action
			<p>Enter AMA_XLA_OPT to control billing options relating to AMA billing translations data.</p>
			<p>Enter CORRELATION_ID to append an AMA module 611 (80014) with a significant digits count of 7 which only includes Correlation ID to associate all billing records produced by an IN call triggering at TDP-2 or TDP-3 resulting from a single call origination. A further optional parameter of RECORD_IND can be entered to also include additional information.</p>
			<p>If CORRELATION_ID is not present, no extension module will be appended.</p>
			<p>This functionality does not apply to the sFBillingChargingCharacteristics parameter of the ActivateServiceFiltering operation.</p>
	<p>CORRELATION_ID_OPTIONS (Subfield of CORRELATION_ID)</p>	<p>RECORD_IND or leave blank</p>	<p>Enter RECORD_IND to increase the significant digit count to 10 to include Correlation ID, last Record Indicator and Record Count.</p>
	<p>DIALED_DIGITS_MODULE (Subfield of DIALED_DIGITS_INFO)</p>	<p>MODULE_28 or MODULE_40 or MODULE_612 or NONE</p>	<p>Enter MODULE_28 to add module code 028 to the base AMA record.</p> <p>Enter MODULE_40 to add module code 040 to the base AMA record.</p> <p>Enter MODULE_612 to add module code 612 (with context identifier 80012) to the base AMA record.</p>

## Field descriptions

Field	Subfield	Entry	Explanation and action
			<p>Enter NONE to remove the DIALED_DIGITS_INFO option.</p> <p>Refer to the AMA Reference Guide, 297-80nn-800, for more information on billing.</p>
	AMA_XLA_INFO_OPT (Subfield of AMA_XLA_OPT)	MAINTN_CALLCODE, MAINTN_OCI	<p>Enter MAINTN_CALLCODE to allow the SSP to open a billing record for terminating call legs that are set up subsequent to the original one, even if translations determines that the call is not billable. The Call Type Code in AMA records opened subsequent to the original one will have the same value as the original CTC of the AMA record opened during translations prior to triggering, unless a generic call code is specified in table AMAXLAID for the terminating call leg. This option allows the switch to override the CTC setting when a distinct call code is required in the AMA record for a particular termination.</p> <p>Enter MAINTN_OCI to use the original OCI (originating charge information) for all AMA records which are subsequently generated on a call triggering or retriggering at TDP-3. (In the case of retriggering at TDP-3, the latest OCI or CTC will be used from that point forwards).</p>

**Field descriptions**

Field	Subfield	Entry	Explanation and action
	FORMAT (Subfield of FCI_OPT)	FREEFORM or FORMATID or NONE	<p>Enter FREEFORM if the SCP is a Nortel SCP. The value from the octet string is placed in the Data Descriptor field of AMA module 199.</p> <p>Enter FORMATID if the SCP is a non-Nortel SCP. The range 127-255 is subsequently available to denote a vendor-specific FCIBCC format or IN service. This value is then placed in the Data Descriptor field of AMA module 199.</p> <p>If NONE is entered, the FCI_OPT tuple is disabled and the SSP defaults to non-Nortel FCIBCC processing. Value 255 is entered in the Data Descriptor field in AMA module 199.</p>
	DIGIT_ COLLECTION_INFO	see subfield COLLECTION_OPTION	<p>This option is used to control digit collection functionality. See Note 2 (below table) for restriction.</p>
	COLLECTION_ OPTION	FULL_CDPA, PCUI_BUFFER, DEL_DIGS	<p>Enter FULL_CDPA if the full CalledPartyAddress (translated if the call triggered at TDP-3) must be available before sending an InitialDP.</p> <p>If FULL_CDPA is not present, the benefits of overlap inpulsing are gained. The digits that were available when the call triggered will be present in the InitialDP.</p> <p>Enter PCUI_BUFFER to collect a single stream of incoming inband digits on the SSP using multiple P&amp;CUI operations.</p>

## Field descriptions

Field	Subfield	Entry	Explanation and action
			<p>If PCUI_BUFFER is not present, the SSP will disconnect its digit collection hardware upon completion of a single P&amp;CUI operation. This will save on network resources.</p> <p>Enter DEL_DIGS to specify the number of leading digits to strip from the Called Party Number (CDPN) when building the InitialDP.</p> <p>If DEL_DIGS is not present, the full Called Party Number is sent in the InitialDP.</p>
	DEL_DIGS (Subfield of COLLECTION_ OPTION)	1 to 30	This is the number of leading digits to be stripped from the CDPN when constructing the InitialDP.
	DEL_DIGS_FROM_ AMA (Subfield of DEL_DIGS)	DEL_DIGS_FROM_AMA	Enter DEL_DIGS_FROM_AMA to make the AMA record contain the stripped digits to match the CDPN of the InitialDP. Otherwise, the AMA record contains the unstripped digits.
	SRF_INFO	see subfield INTERNAL_SRF_INFO	This option defines the behavior of the specialized resource function (SRF) pertaining to the ConnectToResource (CTR) INAP operation.

**Field descriptions**

<b>Field</b>	<b>Subfield</b>	<b>Entry</b>	<b>Explanation and action</b>
	INTERNAL_SRF_ INFO	EARLY_ANS	<p>Enter EARLY_ANS for the SSP to send an early answer message on receipt of a ConnectToResource (CTR) operation and establish a two-way speech path.</p> <p>If EARLY_ANS is not present, a one-way speech path is established between the SRF and the calling party.</p>
	EARLY_ANS_DATA (Subfield of INTERNAL_SRF_ INFO)	ANS_ON_PCUI or NO_ANS	<p>Enter ANS_ON_PCUI if it is necessary to send an early answer for the PromptAndCollectUserInformation (PCUI) Internal IP operation only.</p> <p>Enter NO_ANS if an early answer message is not necessary for the Internal IP.</p>
	RESPONSE_INFO	see subfield RESPONSE_INFO_OPTION	<p>This option allows you to re-assign the NCOS value linked to a CS-1R call. This option also indicates the location in the universal translations table to begin post-Connect, Continue or ETC translations.</p>
	RESPONE_INFO_ OPTION	CONNECT_OPT, ETC_OPT, CONTINUE_OPT	<p>Enter CONNECT_OPT to apply the CS-1R point of re-entry control information against the Connect operation. Also refer to Table 2.</p> <p>Enter ETC_OPT to apply the CS-1R point of re-entry control information against the ETC operation. Also refer to Table 2.</p>

## Field descriptions

Field	Subfield	Entry	Explanation and action
			<p>Enter CONTINUE_OPT to apply the CS-1R point of re-entry control information against the Continue operation. Also refer to Table 2.</p> <p>You can enter CONNECT_OPT, ETC_OPT or CONTINUE_OPT as separate options in the tuple.</p>
	EDPS_INFO	see subfield EDPS_INFO_OPTION	This category controls a range of options relating to EDP behaviour.
	EDPS_INFO_OPTION	EXPLICIT, EDP8_DETECT, SUSPEND_RESUME_ALLOWED, RCVR_FAILURE, EDP8_OPT, REDIRECTION_NUMBER	<p>Enter EXPLICIT to activate explicit disarming of undetectable EDPs.</p> <p>If EXPLICIT is not present, then the default of implicit disarming is used, where undetectable EDPs are automatically disarmed by the SSP (i.e., EDPs 4, 5, 6, and 7 are disarmed when the call is answered). This also stops unnecessary dialog between the SSP and SCP.</p> <p>Enter EDP8_DETECT to determine the type of hardware that performs EDP8 supervision.</p> <p>If EDP8_DETECT is not present, an STR card performs EDP8 supervision.</p> <p>Enter REDIRECTION_NUMBER to control the sending of the redirection information parameter of the ERBCSM operation.</p>

**Field descriptions**

Field	Subfield	Entry	Explanation and action
			<p>If REDIRECTION_NUMBER is datafilled and the terminating agent has Redirection Number in the ISUP REL message, Redirection Number is mapped to the Event Report BCSM extension parameter and sent to the SCP.</p> <p>If REDIRECTION_NUMBER is datafilled and Redirection Number is missing in the ISUP REL message for the terminating agent, no mapping is performed and the extension is not sent.</p> <p>Enter SUSPEND_RESUME_ALLOW to tandem suspend and resume messages to the originator.</p> <p>If SUSPEND_RESUME_ALLOW is not present, the SSP will treat the suspend as a release.</p> <p>Enter RCVR_FAILURE to further specify the behaviour of the call if EDP8 is armed and the receiver is out of service. Currently, only SRVC_NO_DROP can be entered which continues the call with IN. If SRVC_NO_DROP is not present, the call continues as a non-IN call.</p> <p>Enter EDP8_OPT to allow the passive call leg to be maintained on a per-service basis if event EDP-8 is encountered on the controlling leg.</p>

## Field descriptions

Field	Subfield	Entry	Explanation and action
	EDP8_DETECT (Subfield of EDPS_INFO_ OPTION)	SPAP	Enter refinement SPAP for the signal processing application peripheral (SPAP) card to perform EDP8 supervision.
	EDP8_OPT (Subfield of EDPS_INFO_ OPTION)	OMIDCALL_REL_P_LEG	<p>Controls the action to drop the passive call leg.</p> <p>If no datafill (default), the passive call leg is only dropped when EDP-8 is detected in the Alerting phase of the call (ringing is being applied to the far end).</p> <p>If set to 'Y', the passive call leg is dropped when EDP-8 is detected in the Active (call has been answered) or the Alerting phases of the call. The value of the default datafill is PRE_ANS</p> <p>If set to 'N', the passive call leg is not dropped when EDP-8 is detected in either the Active (call has been answered) and the Alerting phases of the call.</p>



**Field descriptions**

Field	Subfield	Entry	Explanation and action
		OMIDCALL_WILDCARD_ZERO	<p>If OMIDCALL_WILDCARD_ZERO is datafilled, the Service Switching Point (SSP) will assume that the:</p> <ul style="list-style-type: none"> <li>• Mid-call event specified will be the same as that sent in the iNServiceControlCodeLow parameter</li> <li>• Number of digits will be the same</li> <li>• Upper limit of the range of digits to be collected will be 9's, and have the same number of 9's as the number of 0's supplied in the iNServiceControlCodeLow parameter</li> </ul> <p>For example if the iNServiceControlCodeLow parameter has the value *000 and OMIDCALL_WILDCARD_ZERO is datafilled, the SSP assumes the value of the iNServiceControlCodeHigh parameter to be *999.</p> <p>If OMIDCALL_WILDCARD_ZERO is not datafilled (default), it is not mandatory that the iNServiceControlCodeHigh must be received. If this parameter is not received AND OMID_WILDCARD_ZERO is not datafilled, the digits collected should match those supplied in the iNServiceControlCodeLow parameter.</p> <p>See Note 1 (below table)</p>

## Field descriptions

Field	Subfield	Entry	Explanation and action
	RCVR_FAILURE (Subfield of EDPS_INFO)	SRVC_NO_DROP	If datafilled, the IN dialogue is maintained even if no Specialised Tone Receiver (STR) is available. If not datafilled (default), the call will continue as a non-IN call.
	BCI_INFO	see subfield BCI_INFO_OPTION	This option controls Backwards Call Indicator (BCI) information.
	BCI_INFO_OPTION	EARLY	Enter EARLY to control BCI options of an early ISUP ACM message.
	FIELD (Subfield of BCI_INFO_OPTION)	CHARGE_IND	Enter CHARGE_IND to control options of the charge indicator of the early ISUP ACM.
	CHARGE_INDICATION (Subfield of FIELD)	CHARGE	Enter CHARGE so that all calls that use this service and that cause an early ISUP ACM message to be sent backwards have the charge indicator sent to "charge".
	TCAP_INFO	See subfield INAP_OPT & TCAP_VERSION	
	INAP_OPT	AUTO_CONTINUE	Indicates whether Auto-Continue is used.
	TCAP_VERSION	CCITT_V0, CCITT_V1	Indicates the version of TCAP used on the ITU IN SSP (Blue Book or White Book).  CCITT_V0 indicates Blue Book. CCITT_V1 indicates White Book.  Default = CCITT_V0.
	TCAP_INFO	see subfield TCAP_INFO_OPTION	This option allows per-service control of different TCAP-related parameters.

## Field descriptions

Field	Subfield	Entry	Explanation and action
	TCAP_INFO_OPTION	U_ABORT	<p>Enter U_ABORT to specify the behaviour when the IN dialogue is aborted by a U_ABORT/TC_END message.</p> <p>If U_ABORT is not present, the call will not be taken down by a U_ABORT message.</p>
	U_ABORT_DATA (Subfield of TCAP_INFO_OPTION)	CLEAR_CALL	Enter CLEAR_CALL to take down the call on a U_ABORT message.
	FI	see subfield FI_OPTION	This option allows per-service control of interactions between IN and DMS-100 features.
		RETRIG_OPTION	This option controls the interaction of the Call Forward feature and its variants.
		RAG	<p>If RAG is datafilled, interaction of IN with the Ring Again and Network Ring Again features is allowed and the call leg generated when the RAG feature is activated can trigger as an IN call.</p> <p>If RAG is not datafilled this restricts the use of the RAG feature.</p>
		ACB	<p>If ACB is datafilled, interaction of IN with the Automatic Call Back feature is allowed and the call leg generated when the ACB feature is activated can trigger as an IN call.</p> <p>If ACB is not datafilled, this restricts the use of the ACB feature.</p>

## Field descriptions

Field	Subfield	Entry	Explanation and action
		AR	<p>If AR is datafilled, interaction of IN with the Automatic Recall feature is allowed and the call leg generated when the AR feature is activated can trigger as an IN call.</p> <p>If AR is not datafilled, this restricts the use of the AR feature.</p>
	FI_OPTION	3WC	Enter 3WC to control three way call interactions.
	FI_ACTION (subfield of FI_OPTION)	TAKE_CONTROL, or CLEAR_CALL, or DENY_FEATURE	<p>Enter TAKE_CONTROL to allow the activated feature to take control of the call and abort the IN dialogue.</p> <p>Enter CLEAR_CALL to allow the call to be terminated if an attempt to activate the feature occurs when the IN dialogue is active.</p> <p>Enter DENY_FEATURE to prevent the feature being activated when the IN dialogue is active.</p>
	CS1R	see subfield CS1R_INFO	This option allows CS-1R Handling of the INAP Operations specified on a per-service basis.
	CS1R_INFO	CONTINUE, CWA	<p>Enter CONTINUE for CS-1R handling of the Continue operation.</p> <p>Enter CWA for CS-1R handling of the ContinueWithArguments operation.</p>
	INITDP_UK_ EXTENSIONS	NATIONAL_FWD_CALL_ IND	Adds the National Forward Call Indicator to InitDP operation (if the parameter is supported in the incoming agent).

**Field descriptions**

<b>Field</b>	<b>Subfield</b>	<b>Entry</b>	<b>Explanation and action</b>
		PRESENTATION_NO	Adds the Presentation Number to InitDP operation (if the parameter is supported in the incoming agent).
		LAST_DIV_LINE_ID	Adds the Last Diverting Line ID to the InitDP operation (if the parameter is supported in the incoming agent).
		PARTIAL_CLI	Adds the Partial Calling Line Identifier to the InitDP operation (if the parameter is supported in the incoming agent).
		CALLED_SUBS_BSM	Adds the Called Subscribers Basic Service Marks to the InitDP operation (if the parameter is supported in the incoming agent).
		CALLING_SUBS_BSM	Adds the Calling Subscribers Basic Service Marks to the InitDP operation (if the parameter is supported in the incoming agent).
		CALLING_SUBS_OFM	Adds the Calling Subscribers Originating Facility Marks to the InitDP operation (if the parameter is supported in the incoming agent).
		CALLED_SUBS_TFM	Adds the Called Subscribers Terminating Facility Marks to the InitDP operation if the parameter is supported in the incoming agent.

## Field descriptions

Field	Subfield	Entry	Explanation and action
		CLI_NAME	<p>Controls the sending of the name extension parameter of the InitialDP operation. If CLI_NAME is datafilled the name parameter will be sent in the InitialDP.</p> <p>The name parameter for trunk-originating calls is derived from the IAM message. For line-originating calls it is derived from datafill of the DNATTRS table.</p> <p>If no name parameter can be found for the call, but CLI_NAME is datafilled, an empty name parameter (no length) is sent.</p>
	CCBS		This option specifies whether Network CCBS and Nodal CCBS can interact with ITU IN.

**Note:****1. Wildcard Zero**

During a RequestReportBSCMEvent (RRBCSME) operation the legID parameter specifies the leg of a call that the system monitors for the occurrence of a specified event.

The MidCallControlInfo parameter indicates the specific mid-call events (OmidCall), which are requested to be Monitored. This is done as a result of the calling party pressing the \* key, pressing the # key, or pressing either of those keys. The MidCallControlInfo parameter can contain one or two MidCallInfoType elements, each using iNServiceControlCodeLow to specify a single control code.

Prior to MMP16, the digits which caused EDP-8 to be encountered were limited to \* or #. These digits were specified in the iNServiceControlCodeLow parameter, a subparameter of the MidCallInfoType parameter of the RRBCSME operation. EDP-8 can only be armed on the controlling leg. At MMP16, additional digits are supported for iNServiceControlCodeLow, and support for

iNServiceControlCodeHigh is added. This allows the Service Control Point (SCP) to specify a range of digits which must be collected when EDP-8 is encountered, in addition to the digit which would cause EDP-8 to be encountered.

The iNServiceControlCodeLow and iNServiceControlCodeHigh parameters of the RRBCSME are used to specify the mid-call event(s) to be detected and the number and range of digits that can be collected by the Service Switching Point (SSP) when EDP-8 has been armed. The iNServiceControlCodeHigh parameter specifies a mid-call event and the upper limit of the range of digits which can be collected. However, it is possible to datafill table SERVINFORM (using EDP8\_WILDCARD\_ZERO) such that a mid-call event and a number and range of digits can be assumed without the need for a iNServiceControlCodeHigh parameter.

EDP8\_WILDCARD\_ZERO allows a range of digits to be accepted when only the iNServiceControlCodeLow parameter is received. If EDP8\_WILDCARD\_ZERO is datafilled, the range of digits collected will correspond to the number of zeroes contained in the iNServiceControlCodeLow parameter. For example, if the value of iNServiceControlCodeLow is \*000, and EDP8\_WILDCARD\_ZERO is datafilled, the range of digits to be accepted is assumed to be \*000 to \*999 even though no iNServiceControlCodeHigh is received.

## 2. Digit buffering

Buffering of digits dialled by the calling party in response to the PromptAndCollectUserInformation operation is not supported on IN calls originating on ETSI PRI or lines, or IN calls triggering on QSIG. Digits dialled after a P&CUI Return Result has been sent and before any subsequent P&CUI operation is received will be lost.

**RESPONSE\_INFO\_OPTION=CONNECT\_OPT, CONTINUE\_OPT, ETC\_OPT, or all**

If the entry in the RESPONSE\_INFO\_OPTION subfield is CONNECT\_OPT, CONTINUE\_OPT, ETC\_OPT, or all, add data to subfield RESPONSE\_INFO\_OPTION\_ATTR as described in the following table.

**Table 2.) Field descriptions for conditional datafill**

Field	Subfield or refinement	Entry	Explanation and action
	RESPONSE_INFO_OPTION_ATTR	NCOS_MODIFY, XLA_REENTRY, or both	<p>Response information option attribute. This optional subfield indicates that the following characteristics of the CS-1R call are subject to change:</p> <ul style="list-style-type: none"> <li>• NCOS value</li> <li>• post-Connect translations behavior</li> <li>• post-Continue translations behaviour</li> <li>• post-ETC translations behavior</li> </ul> <p>Enter NCOS_MODIFY to indicate that the NCOS value is subject to changes related to the INNCOS table during SCP response translations.</p> <p>Enter XLA_REENTRY to indicate that the translations behavior is subject to change during SCP response translations. Also refer to Table 3.</p>



**RESPONSE\_INFO\_OPTION\_ATTR=XLA\_REENTRY**

If the entry in the RESPONSE\_INFO\_OPTION\_ATTR subfield is XLA\_REENTRY, add data to subfield XLA\_REENTRY\_ATTR as described in the following table.

**Table 3.) Field descriptions for conditional datafill**

Field	Subfield or refinement	Entry	Explanation and action
	XLA_REENTRY_ATTR	INNCOS_LOOKUP, UNIV_XLA, or both	<p>Translations re-entry attribute. This optional subfield indicates the location in universal translations to begin post-SCP operation processing.</p> <p>Enter INNCOS_LOOKUP to indicate that post-SCP operation processing begins from a translations point indicated in the INNCOS table.</p> <p>Enter UNIV_XLA to indicate the location in universal translations to begin post-SCP operation processing. Also refer to Table 4.</p>

**XLA\_REENTRY\_ATTR=UNIV\_XLA**

If the XLA\_REENTRY\_ATTR subfield is UNIV\_XLA, add data to subfield UXLA\_DATA as described in the following table.

**Table 4.) Field descriptions for conditional datafill**

Field	Subfield or refinement	Entry	Explanation and action
	UXLA_DATA	see subfields	Translations data. This subfield includes subfields XLASYS and XLANAME.
	XLASYS	AC, AM, CT, FA, FT, NSC, OFC, PX, or NIL	<p>Translations system. Enter the translations system to identify the start point for post-SCP operation translations.</p> <p>Enter AC to indicate the access code system.</p> <p>Enter AM to indicate the ambiguous code system.</p> <p>Enter CT to indicate the city code system.</p> <p>Enter FA to indicate the system of the foreign area code.</p> <p>Enter FT to indicate the feature code system.</p> <p>Enter NSC to indicate the system of the number service code.</p>

Table 4.) Field descriptions for conditional datafill

Field	Subfield or refinement	Entry	Explanation and action
			Enter OFC to indicate the office code system. Enter PX to indicate the prefix code system. Enter NIL to indicate that no translations system is available.
	XLANAME	alphanumeric (1 to 8 characters)	Translator name. Enter the translator to identify the start point for post-SCP operation translations. Enter the index into the table identified by the XLASYS subfield.

### RETRIG\_OPTION=RETRIG\_ACTION, RETRIG\_ALLOW\_BASIS, RETRIG\_PRIORITY

RETRIG\_OPTION has the suboptions and fields listed as follows.

Table 5.) Field descriptions for conditional datafill

Field	Subfield or refinement	Entry	Explanation and action
	RETRIG_ACTION	DENY, DENY_AND_CLEAR, ALLOW	Controls whether an IN call can re-trigger on the call leg being forwarded by the CFW feature. DENY prevents the call leg from triggering. DENY_AND_CLEAR disallows the trigger and sends the call to treatment. ALLOW takes down the existing dialogue and allows the new leg to trigger a new IN dialogue
	RETRIG_ALLOW_BASIS	GT, GTE	This suboption must be datafilled if ALLOW is datafilled in RETRIG_ACTION above. It controls the priority of the attempted re-trigger over the existing dialogue.
	RETRIG_PRIORITY	0 to 255	Priority level of the new call leg.

### Datafill example

The following examples show sample datafill for table SERVINFO.

## MAP display example for table SERVINFORM

SERVIDX	OPTION
666	(INITDP_PARMS ( SERVKEY) (CDPA) (CLI) (CPC) (BC) (EVENT_TYPE) (OCN) (RDN) (DD) (RD_INFO) \$) (BILL_INFO (AMA_OPT (DIALED_DIGITS_INFO MODULE_28) (AMA_XLA_OPT ( MAINTN_OCI ) (MAINTN_CALLCODE ) \$) (CORRELATION_ID (RECORD_IND) \$)\$) (FCI_OPT FREEFORM ) \$) (DIGIT_COLLECTION_INFO ( FULL_CDPA ) (PCUI_BUFFER ) (DEL_DIGS 5)\$) (SRF_INFO (EARLY_ANS ANS_ON_PCUI) \$) (RESPONSE_INFO ( CONNECT_OPT (NCOS_MODIFY ) (XLA_REENTRY (INNCOS_LOOKUP ) (UNIV_XLA PX PUBLPX) \$)\$) (CONTINUE_OPT (NCOS_MODIFY ) (XLA_REENTRY (INNCOS_LOOKUP ) (UNIV_XLA PX PUBLPX) \$)\$) (ETC_OPT (NCOS_MODIFY ) (XLA_REENTRY (INNCOS_LOOKUP ) (UNIV_XLA PX PUBLPX) \$)\$)\$) (EDPS_INFO ( EXPLICIT ) (EDP8_DETECT SPAP) (SUSPEND_RESUME_ALLOW ) (RCVR_FAILURE SRVC_NO_DROP) \$) (TCAP_INFO (U_ABORT CLEAR_CALL) \$) (FI (3WC CLEAR_CALL) \$) (CS1R (CONTINUE) (CWA) \$)\$
777	(INITDP_PARMS ( SERVKEY) (CDPA) (CPC) (EVENT_TYPE) \$) (BILL_INFO (FCI_OPT FREEFORM ) \$) (DIGIT_COLLECTION_INFO ( FULL_CDPA ) \$) (EDPS_INFO ( EXPLICIT ) (EDP8_DETECT SPAP) \$) (CS1R (CONTINUE) (CWA) \$)\$
888	(INITDP_PARMS ( SERVKEY) (CDPA) (CLI) (CPC) (EVENT_TYPE) \$) (BILL_INFO (FCI_OPT FREEFORM ) \$) (EDPS_INFO ( EXPLICIT ) (RCVR_FAILURE SRVC_NO_DROP) \$) (CS1R (CONTINUE) (CWA) \$)\$
9999	(INITDP_PARMS (SERVKEY) (CDPA) (CLI) (CPC) (EVENT_TYPE) \$) (BILL_INFO (FCI_OPT FREEFORM) \$) (EDPS_INFO (EXPLICIT) \$) (CS1R (CONTINUE) (CWA) \$) (FI(3WC TAKE_CONTROL)(RETRIC_OPTION(ALLOW (GT (1)))\$(RAG)(ACB)(AR)\$)

## MAP display example for Merging GSP IN functionality with MMP IN functionality (59028011)

SERVIDX	OPTION
1	(BCI_INFO (EARLY CHARGE_IND CHARGE) \$) (INITDP_PARMS (SERVKEY) (CDPA) (CLI) (CPC) (BUS_GROUP) (BC) (EVENT_TYPE) (OCN) (RDN) (DD) \$) (BILL_INFO (AMA_OPT (DIALED_DIGITS_INFO MODULE_28) (AMA_XLA_OPT (MAINTN_OCI) \$)\$) (FCI_OPT FREEFORM) \$) (DIGIT_COLLECTION_INFO (FULL_CDPA) (PCUI_BUFFER) (DEL_DIGS 1)\$) (SRF_INFO (EARLY_ANS ANS_ON_PCUI) \$) (RESPONSE_INFO (CONNECT_OPT (NCOS_MODIFY) (XLA_REENTRY (INNCOS_LOOKUP) (UNIV_XLA AC NIL) \$)\$) (CONTINUE_OPT (NCOS_MODIFY) (XLA_REENTRY (INNCOS_LOOKUP) (UNIV_XLA PX NIL) \$)\$) (ETC_OPT (NCOS_MODIFY) (XLA_REENTRY (INNCOS_LOOKUP) (UNIV_XLA PX PUBL100S) \$)\$)\$) (EDPS_INFO (EXPLICIT) (EDP8_DETECT SPAP) (RCVR_FAILURE SRVC_NO_DROP) \$) (TCAP_INFO (U_ABORT CLEAR_CALL) \$) (FI (3WC TAKE_CONTROL) \$)(CS1R (CONTINUE) (CWA) \$) (INITDP_UK_EXTENSIONS(NATIONAL_FWD_CALL_IND)(PARTIAL_CL) \$)I\$

## MAP display example for option EDP8\_OPT in table SERVINFORM (59027976)

TOP SERVIDX	OPTION
6666	(INITDP_PARMS (SERVKEY) (CDPA) (CPC) (EVENT_TYPE) \$) (BILL_INFO (AMA_OPT (DIALED_DIGITS_INFO MODULE_40) \$) (FCI_OPT FREEFORM) \$) (DIGIT_COLLECTION_INFO (FULL_CDPA) \$) (EDPS_INFO (EXPLICIT) \$) (CS1R (CONTINUE) (CWA) \$)\$
7777	(DIGIT_COLLECTION_INFO (FULL_CDPA) \$) (EDPS_INFO (EXPLICIT) (RCVR_FAILURE SRVC_NO_DROP) (SUSPEND_RESUME_ALLOW) (EDP8_OPT (OMIDCALL_WILDCARD_ZERO) \$)\$ (OMIDCALL_REL_P_LEG Y) \$)\$)\$

**MAP display example for option RD\_INFO in table SERVINFO**

```
TOP
SERVIDX                                     OPTION
-----
5555 (INITDP_PARMS (SERVKEY) (CDPA) (CLI) (CPC) (BUS_GROUP)
      (BC) (EVENT_TYPE) (OCN) (RDN) (DD) (RD_INFO) (FWD_CI) $)$
```

**MAP display example for option REDIRECTION\_INFO in table SERVINFO**

```
TOP
SERVIDX                                     OPTION
-----
4444 (EDPS_INFO (REDIRECTION_NUMBER $))
```

**Table history**

**CSP18/SN05**

Added option CCBS to extend the capability for IN triggering at TDP2 and TDP3 to include Nodal and Network CCBS for feature 59038655.

**SN04 (DMS)**

Added suboption DEL\_DIGS\_FROM\_AMA to the DEL\_DIGS option for ProSTAR 30374181.

New entry CLI\_NAME added to field INITDP\_UK\_EXTENSIONS for feature 59033637.

New entries RETRIG\_OPTION, RAG, ACB & AR added to field FI for feature 59033609.

Subfields INAP\_OPT and TCAP\_VERSION added for feature 59033629.

Added suboption REDIRECTION\_NUMBER to the EDPS\_INFO option and suboption RD\_INFO to the INITDP\_PARMS option for feature 59033624.

**MMP16**

Note added concerning restriction on digit collection (Prostar 30362171).

**MMP16**

Subfield FWD\_CI added to field INITDP\_PARMS (59027982).

**MMP16**

The following changes were made to this table for feature EDP-8 (o\_Mid\_Call) enhancements (59027976):

- New field EDP8\_OPT added with two subfields:
  - OMIDCALL\_REL\_P\_LEG  
to allow the passive call leg to be maintained on a per-service basis if event EDP-8 is encountered on the controlling leg.
  - OMIDCALL\_WILDCARD\_ZERO  
to allow a range of digits to be collected without using an upper limit parameter.
- New sub-field SRVC\_NO\_DROP added to determine if the call continues as an IN call if no Specialised Tone Receiver (STR) is available.

**MMP16**

The following changes were made to this table for feature Global Services Platform (GSP) agency equivalence (59028011):

- Merges the Intelligent Networking (IN) functionality, provided on the GSP, with the MMP IN functionality.
- Introduces IN support for the following new trunk agents:
  - UK ISUP (an implementation of ETSI ISUP Version 3)
  - Brazilian TUP
  - Brazilian R2
  - Brazilian ISUP
  - Dutch PRI (a variant of ETSI PRI)
  - German EURO ISDN (ETSI PRI and BRI)

- The following TDPs will be supported on the above listed agents:
    - TDP-2 (Information Collected) using the Minimum Digits and Specific Digits String criteria
    - TDP-3 (Analyzed Information) using all trigger criteria
  - The following EDPs will be supported on the above agents:
    - EDP-2 (Collected Info) as a Request or Notification DP
    - EDP-4 (Route\_Select\_Failure) as a Request or Notification DP (Internal and External)
    - EDP-5 (o\_Called\_Party\_Busy) as a Request or Notification DP
    - EDP-6 (o\_No\_Answer) as a Request or Notification DP
    - EDP-7 (o\_Answer) as a Notification DP (and -R for CPH)
    - EDP-8 (o\_Mid\_Call) as a Request or Notification DP
    - EDP-8 (o\_Mid\_Call on leg 2) as a Request or Notification DP
    - EDP-9 (o\_Disconnect) as a Request or Notification DP
    - EDP-9 (o\_Disconnect on leg 1) as a Request or Notification DP
    - EDP-10 (o\_Abandon) as a Request or Notification DP
- Transparent mode is also supported on all of the above EDPs.

### **MMP15**

The following changes were made to this table for feature IN Enhancements (A59023749):

- Subfield RD\_INFO added to field INITDP\_PARMS.
- Subfield SUSPEND\_RESUME\_ALLOW added to field EDPS\_INFO.
- Field CS1R added to override CS2 handling of Continue and CWA. (A59023770)

### **MMP14**

The following changes were made to this table:

- Field FI and subfields FI\_OPTION and FI\_ACTION added for feature Line Triggering Feature Interaction Enhancement.
- Field TCAP\_INFO and subfield U\_ABORT added for feature Line Triggering Feature Interaction Enhancement.

**MMP13**

The following changes were made to this table in MMP13:

- Field EARLY\_ANS replaced field ONE\_WAY. Refinements ANS\_ON\_PCUI and NO\_ANS added.
- Field EDP8\_DETECT added.
- MAINTN\_OCI added, and field MAINTAIN renamed to MAINTN\_CALLCODE for 59012663.
- DEL\_DIGS subfield added to DIGIT\_COLLECTION\_INFO for 59012675.
- P&CUI\_BUFFER subfield added to DIGIT\_COLLECTION\_INFO for 59015002.

**EUR010 / APC11**

The following changes were made in this release:

- Field BILLING\_INFO added.
- Field AMA\_INFO changed to a subfield of field BILLING\_INFO.
- Field FCI\_OPT and subfields FORMAT and FORMAT\_IDENTIFIER added.
- Option EDPS\_INFO and subfield DISARMING added.
- Value CORRELATION\_ID added to the range of values for field AMA\_INFO\_OPTION.

**EUR009 / APC010**

Added values OCN, RDN, and DD to the INITDP\_PARM\_INFO subfield in the OPTION field.

Added the RESPONSE\_INFO\_OPTION option to the OPTION field.

Added options BCI\_INFO and AMA\_XLA\_INFO\_OPTION.

**EUR008**

The following changes were made to this table in EUR008:

- MODULE\_612 added to DIALED\_DIGITS\_MODULE option.
- Key to table SERVINFORM changed from SERVKEY to SERVIDX.
- Subfield INITDP\_INFO deleted from the OPTION field.
- Subfields INITDP\_PARAMS and INITDP\_PARM\_INFO added to the OPTION field.
- Subfield DIGIT\_COLLECTION\_INFO added to the OPTION field.
- Subfield INTERNAL\_SRF added to the OPTION field.



**EUR006**

Added subfields IN\_BUS\_GRP and BEARER\_CAPABILITY to the INITDP\_INFO field.

Altered the function of subfield CALLING\_PN.

**EUR004**

Table SERVINFO was introduced.

---

**SERVNAME**

---

**Table name**

Traffic Operator Position System Service Rating Name Table

**Overview**

A called number is defined as service in table SERVSCRN and is associated with a service name. The name is defined by the customer. Table SERVNAME is used to create new service names. The service names are used to index table SRVRS. Table SRVRS associates a previously defined tariff and a service name with a schedule and ratestep.

For related information, refer to tables SERVSCRN and SRVRS.

**Functional description**

Table SERVNAME defines rating names. The rating is defined by the customer.

**Datafill sequence and implications**

There is no requirement to datafill other tables prior to table SERVNAME.

**Table size**

2 to 63 tuples

When deleting tuples in table SERVNAME, ensure that at least two tuples remain datafilled: to delete all tuples in this table is highly dangerous and unsupported.

**SERVNAME** (end)

**Datafill**

The following table lists datafill for table SERVNAME.

**Field descriptions**

Field	Subfield or refinement	Entry	Explanation and action
VALUE	UNINT	0 to 63	Value. Enter the value of position in table. Value 0 (zero) is predefined to represent NIL_SRV_TYPE. Value 1 is predefined to represent TOLLFREE.  The DMS MAP shows the range 0 to 32767; however, any entry outside the range indicated for this field in the entry column is invalid.
SYMBOL		alphanumeric (up to 32 characters)	Service rating name. The service rating name is customer-defined. Enter the service rating name defined in tables SERVSCRN and SRVRS.

**Datafill example**

The following example shows sample datafill for table SERVNAME.

**MAP display example for table SERVNAME**

VALUE	SYMBOL
0	NILSERV
1	TOLLFREE
2	FOREIGNDA
3	LOCALDA

**Table history**

**BCS36**

Added section "Table size" and associated information

---

## SERVRINV

---

**ATTENTION**

This table applies to new or modified content for SN09 (DMS) that is valid through the current release.

### Server Inventory

Table SERVRINV stores provisioned data for a Gateway Controller (GWC) or an Audio Server (AUD), which are nodes in CS2000 cable network configuration. This table contains fields for a server name, which is a unique identifier of a GWC and its number for a given line or trunk GWC. The next field stores the server address, which is the IP address needed for inter-GWC communication. The server exec and server tone fields hold information for terminal and tone set type.

The customer must manually enter data in this table with the table editor ADD and NEW commands. You cannot use the table editor CHG command to change this table. Use the Service Order System (SERVORD) ADO, DEO, and CHF commands to change this table. The maximum number of GWCs you can provision is 210.

### Datafill sequence and meaning

The following tables must be datafilled after you have datafilled table SERVSINV:

- LGRPINV
- LNINV

### Table size

Maximum of 210 tuples. Allocation occurs dynamically.

## Datavill

The following table lists datavill for table SERVRINV.

### Field descriptions

Field	Subfield or refinement	Entry	Explanation and action
SRVRNAME	SRVR_KEY	SRVR_KEY is an area refinement of KEY. It is a multiple with PMTYPE, PM_TYPE and PMNO, XPM_NO (0 to 255)	Server name. For the GWC, the PMTYPE is GWC and the PMNO is an integer from 0 to 255.
SRVRADDR	SRVRADDR ES_AREA	Multiple with NETWORK (IP, ATM, NOADDR) refinements: IP, IPADDRSS table of 4 (0 to 255), ATM, multiple with ATMADDRSS, multiple with VIRTUAL_CHANNEL (0 to 255), VIRTUAL_PATH (0 to 255)	Server address. An IP address is needed for fabric control message (FCM). When the CM sends an FCM to a GWC, the GWC needs to know the IP address of the other GWC to communicate. Note: Only IP is available for the alpha 1 release.

**Field descriptions**

Field	Subfield or refinement	Entry	Explanation and action
SRVREXEC	TERM_EXE C_TC_TAB	TERM_EXEC_ TC_TAB vector of up to 8 multiples with TRMTYPE TERM_TYPE EXEC EXEC_LINEUP	<i>Server exec</i> For a GWC, EXECTAB could be (POTS POTSEX) \$.
SRVRTONE	TONE_SET_ TYPE	HONGKONG, INDIA, SRILANKA, CHINA100, AUS100, MEXDTMF, MEXMF, NZLGC, CHINA, MOROCCO, NZDTC, AUS300, CEP, CEP100, NORTHAM, JAPAN1, NORTHAA, NA_RAM	<i>Server tone</i> Specify the tone set for the GWC. For North America, specify NORTHAM.

**Table history****SN09 (DMS)**

Table SERVRINV added to DMS-100 documentation for Q01063949.



---

**SERVSCRN**

---

**Table name**

TOPS Service Screen Table

**Functional description**

Table SERVSCRN lists the called number and the associated service name.

For the first application of this table, tuple NPA 555-1212 TOLLFREE must be added to table SERVSCRN. On subsequent applications, this table should be dumped and restored.

A called number should not be datafilled both as a local call and a service call. If it is, the service designation is accepted.

Called numbers with a NPA of 800 should not be entered into table SERVSCRN.

Table SERVSCRN prevents LATA screening when codes, which have appeared in table SERVSCRN, are bypassed by default datafill, which adds codes 20055 through 919555. This table skips codes 800555. It is the choice of the operating company to remove any other codes, such as 700 or 900, that they wish to screen through table LATAXLA. Refer to OSB TOPS Service Billing in the *TOPS translations section*

Table SERVSCRN is standard to the TOPS package.

**Datafill sequence and implications**

The following tables must be datafilled before table SERVSCRN.

- SERVNAME
- SCHED
- SCHEDI

**Table size**

0 to 32 767 tuples



**SERVSCRN** (continued)

---

**Datafill**

The following table lists datafill for table SERVSCRN.

**Field descriptions**

<b>Field</b>	<b>Subfield or refinement</b>	<b>Entry</b>	<b>Explanation and action</b>
CLDNUM		0 to 9 (up to 18 digits)	Called number. Enter a called number.
SERVNAME		alphanumeric (up to 16 characters)	Service rating name. Enter the service rating name. This name must be datafilled in tables SERVNAME and SRVRS.

**Datafill example**

The following example shows sample datafill for table SERVSCRN.

---

**SERVSCRN** (end)

---

**MAP display example for table SERVSCRN**

CLDNUM	SERVNAME
--------	----------

---

817555	TOLLFREE
818555	TOLLFREE
819555	TOLLFREE
900555	TOLLFREE
901555	TOLLFREE
902555	TOLLFREE
903555	TOLLFREE
904555	TOLLFREE
905555	TOLLFREE
906555	TOLLFREE
907555	TOLLFREE
908555	TOLLFREE
909555	TOLLFREE
910555	TOLLFREE
911555	TOLLFREE
912555	TOLLFREE
913555	TOLLFREE
914555	TOLLFREE
915555	TOLLFREE
916555	TOLLFREE
917555	TOLLFREE
918555	TOLLFREE
919555	TOLLFREE

## SERVSINV

---

### Table name

Server Subtending Node Inventory

### Functional description

Table SERVSINV contains the names of the server subtending nodes and their associated gateways. The subtending nodes are the Audio Controller (AUD) and the Dynamic Packet Trunk (DPT).

Table SERVSINV supports the following commands:

- ADD
- DEL
- CHA

*Note:* CHA is only supported for the AUD node.

### Datafill sequence and meaning

Enter datafill into table SERVRINV before table SERVSINV.

Enter datafill into the tables that follow after you enter datafill into table SERVSINV:

- ANNMEMS
- CONF3PR

### Table size

Maximum tuples 256

**SERVSINV** (continued)

**Datafill**

The table that follows lists datafill for table SERVSINV.

**Field descriptions**

Field	Subfield or refinement	Entry	Explanation and action
SRVSNAME		multiple with XPMTYPE PM_TYPE XPMNO (0 to 255)	Server Subtending Name field. Enter AUD, DPT, or BCT for the PM type. Enter a PM number between 0-255.
SRVRNAME		multiple with XPMTYPE PM_TYPE XPMNO (0 to 255)	Server Name field. Enter GWC for the PM type. Enter the PM number that is present in table SERVRINV.
NUMTERMS		1024, 2048, or 4095	Number of Terminals field. This field represents the number of terminals of the node. This field must be 2048 for DPT.
OPTIONS		SIPT, SIPSNODE, BICC, ANNC, 3PORT, 6PORT, ALTTERMS	Options field. Enter options: SIPT, SIPSNODE, BICC, ANNC, 3PORT, 6PORT, and/or ALTTERMS.
<b>OPTION = SIPT, SIPSNODE or BICC</b>			<p>SIPT is used to provision SIP-T GWCs. This option adds the GWC node to the DDM's VRDN table node list. The GWC receives the list of VRDN information from the DDM during RTS static data download. Enter the IP address of the VRDN. Enter any valid IP address when provisioning a SIP-T GWC.</p> <p>BICC is used to provision the DPT subtending GWCs with Bearer Independent Call Control (BICC) capability.</p> <p>SIPSNODE is used to provision SIP Service Node resources on the DPT.</p>
For OPTION = SIPT, SIPSNODE or BICC there are no subfields.			

**SERVSINV** (continued)**Field descriptions**

Field	Subfield or refinement	Entry	Explanation and action
<b>OPTION = ANNC</b>			
ANNC is used to control the number of announcement calls to an audio server.			
For OPTION = ANNC there is subfield ANNTERMS.			
	ANNTERMS	1 to 300	Announcement terminals. Defines the number of ports for announcement calls on the audio server. Enter value between 1 to 300.
<b>OPTION = 3PORT or 6PORT</b>			
3PORT is used to indicate the number of 3-port conferencing circuits on the audio server.			
6PORT is used to indicate the number of 6-port conferencing circuits on the audio server.			
For OPTION = 3PORT or 6PORT there is subfield CONFTERMS.			
	CONFTERMS	(for 3PORT): 3 to 4092	Indicates the number of 3-port conference ports. Value has to be divisible by 3 and the result is the number of 3-port circuits reserved on the audio server. For example 30 ports provisioned means there are 10 3-port conference circuits.
		(for 6PORT): 6 to 2046	Indicates the number of 6-port conference ports. Value has to be divisible by 6 and the result is the number of 6-port circuits reserved on the audio server. For example 30 ports provisioned means there are 5 6-port conference circuits.
<b>OPTION = ALTTERMS</b>			
ALTTERMS is used to provision the number of BCT resources on the audio server.			

## SERVSINV (continued)

### Field descriptions

Field	Subfield or refinement	Entry	Explanation and action
For OPTION = ALTTERMS there is subfield ALTTERMS.			
		0 to 4095	Indicates the number of BCT resources. This number is usually the number of CG6000 cards dedicated to BCT multiplied by 90 (since there are 90 terminals per card). For ATM networks, this number should be 500 per audio server.

### Datafill example

The figures that follows shows sample datafill for table SERVSINV.

#### MAP display example for table SERVSINV, showing ANNC option

SRVSNAME	SRVRNAME	NUMTERMS	OPTIONS
AUD 0	GWC 4	4095	( 3PORT 30) ( 6PORT 30)( ANNC 50)\$
AUD 1	GWC 5	4095	( ANNC 100)\$
DPT 0	GWC 6	2048	( SIPT )\$
BCT 0	GWC 4	1024	(ALTTERMS 90)\$

#### MAP display example for table SERVSINV, showing BICC option

SRVSNAME	SRVRNAME	NUMTERMS	OPTIONS
AUD 0	GWC 0	1024	\$
DPT 5	GWC 5	2048	( BICC )\$

### Table history

#### SN06 (DMS)

Feature A19013546: ANNC option added to options field.

Feature A89007299 removes the restriction that the BICC option could not be assigned against a DPT tuple in table SERVSINV.

#### Beta 1

New for this release.

---

**SERVSINV** (end)

---

**Error messages**

The following error messages are given for invalid datafills:

- `ERROR: BICC option is only valid with DPT tuple`  
An attempt has been made to add a non-DPT tuple with BICC option.
- `ERROR: Host PM must be a GWC`  
An attempt to add a DPT tuple with BICC option does not have GWC as the XPMTYPE in the SRVRNAME field.
- `ERROR: Coexistence of BICC and SIPT options in a DPT tuple is not supported`  
An attempt has been made to add a DPT tuple with SIPT and BICC options.
- `ERROR: Maximum DPT nodes already provisioned`  
An attempt to add a DPT tuple with BICC option exceeds the maximum number of DPT tuples in table SERVSINV, which is set to 128.
- `ERROR: Change is not allowed`  
An attempt has been made to remove the BICC option from a DPT tuple.  
An attempt has been made to change the SRVSNAME field of an existing DPT tuple with BICC option.  
An attempt has been made to add BICC option to a DPT tuple with SIPT option.  
An attempt has been made to add SIPT option to a DPT tuple with BICC option.  
An attempt has been made to replace the BICC option in a DPT tuple with SIPT option.  
An attempt has been made to replace the SIPT option in a DPT tuple with BICC option.  
An attempt has been made to change the NUMTERMS field of an existing DPT tuple with BICC option.
- `ERROR: DPT tuple must have either SIPT or BICC option`  
An attempt has been made to add a DPT tuple without SIPT or BICC option.

**Additional information**

You can datafill only 128 DPT tuples in table SERVSINV.

---

## SETDEFS

---

**ATTENTION**

This table applies to new or modified content for SN07(DMS) that is valid through the current release.

## SETDEFS

### Datafill sequence and implications

Datafill follows table AUTOOPTS after a software delivery process. Some of the tuples are generated at IPL time and cannot be altered. All the other tuples are defined by the site via the Post Release Software Manager (PRSM) setdef command and are preserved over a software delivery process.

### Table size

The table may contain up to 256 entries.

### Datafill

It is done via PRSM.

### Fields and subfields for table SETDEFS

Field	Subfield or refinement
DEFNAME	SETDEFS_KEY
SETTYPE	TYPE_OF_PRSMSET
SETDEF	PRSM_DEFINITION_VECTOR

### Table history

#### SN07(DMS)

New table SETDEFS created as part of activity Q01083765.



---

## SFWALARM

---

### Table name

Software Alarm Table

### Functional description

Table SFWALARM is datafilled by the system and contains the data for system alarms.

Entries in table SFWALARM cannot be added or deleted, but the data can be changed by the operating company.

### System alarm functions

Each system alarm is identified by its function. Table 1 lists the definition of each of the system alarm functions.

#### System alarm functions (Sheet 1 of 4)

Function	Definition
ACTPATCH	Activation category patch found in OFF state
ALERT	Alert alarm
CAMASUSP	Centralized automatic message accounting (CAMA) suspension alarm
CAMATRBL	CAMA trouble alarm
CLFALARM	Malicious call hold (line option CLF) alarm
CLIALARM	Calling line identification (CLI) alarm
CMDABUMA	Command abuse major alarm
CMDABUMI	Command abuse minor alarm
CMDUSECR	Command use critical alarm
CMDUSEMA	Command use major alarm
CMDUSEMI	Command use minor alarm
CRITAUD	Critical audible alarm
CRITSYS	Critical system alarm
EMERG_CUT_OFF_ON	Emergency cut-off alarm
ESG	Emergency service group

**SFWALARM** (continued)**System alarm functions (Sheet 2 of 4)**

<b>Function</b>	<b>Definition</b>
JESCALL	Japan emergency service alarm. This alarm alerts operating company personnel that an emergency call routed successfully.
JESUNANS	Japan emergency service unanswered alarm. This alarm alerts operating company personnel the emergency service bureau has not answered the emergency call.
MAJAUD	Major audible alarm
MAJSYS	Major system alarm
MCIDALARM	Malicious call identification alarm
MCTALARM	Malicious call trace alarm
METXRCYL	Meter recycle alarm (activated if recycle meters are detected during or after the third run of the meter audit). This alarm is present only in international switches.
MINAUD	Minor audible alarm
MINSYS	Minor system alarm
NTHQBLKS	Number of table history queue (THQ) blocks available alarm. This alarm indicates that there is less than 10% THQ blocks available. This alarm is turned off by the THQ audit, the charge updating process, and the command THQCLEAN if their actions result in more than 10% free THQ blocks. The alarm is present only in international switches.
OAUSYSFL	Office alarm unit (OAU) system failure alarm
OMTAPE	Operational measurements (OM) tape alarm
PRE_AUTOPATCH_SA	Pre-autopatch sanity failure
PRE_AUTOPATCH_S	Post-autopatch sanity failure
RDTCRT	Remote digital terminal critical alarm
RDTMJ	Remote digital terminal major alarm
RDTMN	Remote digital terminal minor alarm
RDTWRN	Remote digital terminal warning alarm indicator
SECRETCR	Secret critical alarm

**SFWALARM** (continued)**System alarm functions (Sheet 3 of 4)**

<b>Function</b>	<b>Definition</b>
SECRETMA	Secret major alarm
SECRETMI	Secret minor alarm
SCC_CC_ALM	Central control alarm
SCC_CCS_ALM	Common channel signaling alarm
SCC_CMC_ALM	Central message controller alarm
SCC_IO_ALM	I/O alarm
SCC_NMC_ALM	Switching network alarm
SCC_CKT_ALM	Circuit limit alarm
SCC_PM_ALM	Peripheral module (PM) alarm
TOPS_ECP_TOPS	Emergency calls present  <b>Note:</b> This alarm applies only to TOPS customers.
TOPS_ECW_TOPS	Emergency calls waiting  <b>Note:</b> This alarm applies only to TOPS customers.
TOPS_PARS_APPL	Activated if all multiprotocol controller (MPC) datalinks for the Traffic Operator Position System (TOPS) personal audio response system (TOPSPARS) application are taken out of service. The alarm is deactivated when at least one data link is in service for the TOPSPARS application.  <b>Note:</b> This alarm applies only to TOPS customers.
TOPS_PARS_LINK	Activated if any MPC data link for the TOPSPARS application is taken out of service. It is deactivated when all data links for the TOPSPARS application that are datafilled in table MPCFASTS are in service.  <b>Note:</b> This alarm applies only to TOPS customers.

**SFWALARM** (continued)**System alarm functions (Sheet 4 of 4)**

Function	Definition
TOPS_PARS_NODE	Activated if all MPC data links to any personal audio response system (PARS) node are taken out of service. It is deactivated when at least one data link is in service between the DMS switch and each PARS node.  <b>Note:</b> This alarm applies only to TOPS customers.
VSN_CRIT_ALM	Voice service node (VSN) critical alarm
VSN_MAJ_ALM	VSN major alarm
VSN_MIN_ALM	VSN minor alarm
VSN_NO_ALM	VSN no alarm
VSN_NO_LINKS	VSN no-links alarm
VSN_ONE_LINK	VSN one-link alarm

**Signal distributor functions**

The following table lists the preceding system alarm functions and the assignable signal distributor functions. Each system alarm can be assigned a maximum of six signal distributor functions.

**Signal distributor functions (Sheet 1 of 4)**

Function	Definition
ABAUD	Alarm battery supply audible alarm
ABOAU	Alarm battery supply OAU
ABPDC	Alarm battery power distribution center
ALMXFR	Alarm transfer
COMAUD1	Common audible OAU
COMAUD2	Common audible maintenance trunk module (MTM)
CRALMAUD	Critical alarm audible
CRALMVIS	Critical alarm visual
CRPWRVIS	Critical power alarm visual

**SFWALARM** (continued)**Signal distributor functions (Sheet 2 of 4)**

<b>Function</b>	<b>Definition</b>
CRVISLOOP	Critical alarm visual, loop
EXPILDMS	Exit pilot DMS
EXPILPWR	Exit pilot power
LN101TST	101 test line
MJALMAUD1	Major alarm audible
MJALMAUD2	Major alarm audible
MJALMVIS	Major alarm visual
MJOTHVIS	Major alarm, other floor, visual
MJPWRVIS	Major power alarm visual
MJVISLOOP	Major alarm visual, loop
MJXFR	Major alarm transfer
MNALMAUD	Minor alarm audible
MNALMVIS	Minor alarm visual
MNOTHVIS	Minor alarm, other floor, visual
MNPWRVIS	Minor power alarm visual
MNVISLOOP	Minor power alarm visual, loop
MNXFR	Minor alarm transfer
MTMFAIL	Miscellaneous trunk module (TM) failure
MTMPWR	Miscellaneous TM power
NTALMXFER	Night alarm transfer
OAUFAIL	OAU failure
OAUFLAUD	OAU failure audible
OAUFLVIS	OAU failure visual
OAUPWR	OAU power

**SFWALARM** (continued)**Signal distributor functions (Sheet 3 of 4)**

<b>Function</b>	<b>Definition</b>
PDCVIS	Power distribution center visual
PREFLRRCR	Preceding floor critical alarm
PREFLRMJ	Preceding floor major alarm
PREFLRMI	Preceding floor minor alarm
PREFLRPF	Preceding floor power failure
RDTCRIT	Remote digital terminal (RDT) critical alarm
RDTMAJOR	RDT major alarm
RDTMINOR	RDT minor alarm
RDTWARN	RDT warning alarm indicator
SUCFLRCR	Succeeding floor critical alarm
SUCFLRMA	Succeeding floor major alarm
SUCFLRMI	Succeeding floor minor alarm
SUCFLRPF	Succeeding floor power failure
TODFEAT	Time-of-day feature failure audible
TODSYS	Time-of-day system shutdown audible
TOPS_ECP_AUDVIS	Controls the audible and visible alarm devices that are turned on if emergency calls are in the TOPS call-waiting queue  <b>Note:</b> This function applies only to TOPS customers.
TOPS_ECP_RECORD	Controls the recording device used to record emergency calls  <b>Note:</b> This function applies only to TOPS customers.
TRKGPALM	Trunk group alarm
SCC_CC_ALM	Central control alarm
SCC_CCS_ALM	Common channel signaling alarm
SCC_CMC_ALM	Central message controller alarm
SCC_IO_ALM	I/O alarm

**SFWALARM** (continued)**Signal distributor functions (Sheet 4 of 4)**

Function	Definition
SCC_NMC_ALM	Switching network alarm
SCC_CKT_ALM	Circuit limit alarm
SCC_PM_ALM	PM alarm

**Datafill sequence and implications**

This is a read-only table that is automatically datafilled by the system. No additions or deletions by the operating company are permitted.

The hardware alarm scan group must be datafilled in table ALMSCGRP first. The number of tuples that are put into table ALMSCGRP must also be entered into table CLLI for the scan point common language location identifier (CLLI) of OAUSC.

**Table size**

The internal maximum size of table ALMSCGRP is 256, but 20 of that capacity is reserved for table SFWALARM.

**Datafill**

The following table lists datafill for table SFWALARM.

Fields FUNCTION, REPORT, ALM and LOGIC are datafilled if the entry is the first record for the system alarm. If the entry is other than the first entry for the system alarm, datafill field LOGIC and leave the other fields (FUNCTION, REPORT, and ALM) blank.

**Field descriptions (Sheet 1 of 2)**

Field	Subfield or refinement	Entry	Explanation and action
FUNCTION		alphanumeric (vector of up to 16 characters)	<i>Function</i> Enter the alarm function. See the following table.
REPORT		Y or N	<i>Report</i> Enter Y (yes) if an alarm report is logged. Otherwise, enter N (no).

**SFWALARM** (continued)**Field descriptions (Sheet 2 of 2)**

Field	Subfield or refinement	Entry	Explanation and action
ALM		CR, MJ, MN, or NA	<i>Alarm</i> Enter the type of alarm activated: CR (critical), MJ (major), MN (minor), or NA (no alarm).
LOGIC		see subfields	<i>Logic</i> This field consists of subfields SDFUNCT, ALMGRP and ALMXFR.
	SDFUNCT	alphanumeric (up to 16 characters)	<i>Signal distributor function</i> Enter the signal distributor function or functions associated with a specific system alarm. See the following table.
	ALMGRP	Y or N	<i>Alarm grouping</i> Enter Y if the alarm function is invoked when the alarm grouping key is activated. Otherwise, enter N.
	ALMXFR	Y or N	<i>Alarm transfer</i> Enter Y if the alarm function is invoked when the alarm transfer key is activated. Otherwise, enter N.
	CONTMARK	+, \$	Continuation mark. Indicates if additional information for the logic tuple is required. Enter + to continue to add more information. Enter \$ to indicate the end of the logic tuple.

**Datafill example**

Examples of datafill for table SFWALARM are shown on the following pages.

The following example shows datafill for table SFWALARM using several alarm functions.



**SFWALARM** (continued)

## MAP display examples for table SFWALARM

FUNCTION	REPORT	ALM	SDFUNCT	ALMGRP	ALMFXR				
CRITSYS	N	NA	SUCFLRPF	Y	N				
			PREFLRPF	N	N				
			COMAUD1	N	N				
			EXPILDMS	N	N				
			COMAUD2	N	N				
			MJXFR	N	Y				
			CRALMVIS	N	N				
			SUCFLRCR	Y	N				
			PREFLRCR	N	N	\$			
			CRITAUD	N	NA	CRALMAUD	N	N	\$
EMERG_CUT_OFF_ON	N	CR	CRALMVIS	N	N				
			CRALMAUD	N	N				
			EXPILDMS	N	N				
			PREFLRPF	N	N				
			SUCFLRPF	Y	N				
			PREFLRCR	N	N				
			SUCFLRCR	Y	N				
			CRVISLOOP	N	N				
			COMAUD1	N	N	\$			
			MAJSYS	N	NA	SUCFLRMJ	Y	N	
MAJAUD	N	NA	PREFLRMJ	N	N				
			COMAUD1	N	N				
			EXPILDMS	N	N				
			COMAUD2	N	N				
			MJXFR	N	Y				
			MJALMVIS	N	N	\$			
			MJALMAUD1	N	N	\$			
			MJALMAUD2	N	N				
			MINSYS	N	NA	MNALMVIS	N	N	\$
			OMTAPE	Y	MN	MNALMVIS	N	N	
MNALMAUD	N	N							
COMAUD1	N	N							
EXPILDMS	N	N							
COMAUD2	N	N							
PREFLRMN	N	N							
SUCFLRMN	Y	N				\$			

The following example shows datafill for table SFWALARM using function ESG\_ALARM.

**SFWALARM** (continued)**MAP display examples for table SFWALARM**

FUNCTION	REPORT	ALM	SDFUNCT	ALMGRP	ALMFXR	
ESG_ALARM	N	MN	MNALMVIS	N	N	
			MNALMAUD	N	N	
			EXPILDMS	N	N	
			PREFLRMN	N	N	
			SUCFLRMN	Y	N	
			MNVISLOOP	N	N	
			COMAUD1	N	N	\$

The following example shows datafill for table SFWALARM using alarms PRE\_AUTOPATCH\_SA, POST\_AUTOPATCH\_S, and ACTPATCH.

**SFWALARM** (continued)

**MAP display examples for table SFWALARM**

FUNCTION	REPORT	ALM	SDFUNCT	ALMGRP	ALMFXR	
PRE_AUTOPATCH_SA	Y	MJ	MJALMVIS	N	N	
			MJALMAUD	N	N	
			MJALMAUD1	N	N	
			MJALMAUD2	N	N	
			EXPILDMS	N	N	
			PREFLRMJ	N	N	
			SUCFLRMJ	Y	N	
			MJVISLOOP	N	N	
			COMAUD1	N	N	\$
			POST_AUTOPATCH_S	Y	MJ	MJALMVIS
ACTPATCH	Y	MJ	MJALMAUD	N	N	
			MJALMAUD1	N	N	
			MJALMAUD2	N	N	
			EXPILDMS	N	N	
			PREFLRMJ	N	N	
			SUCFLRMJ	Y	N	
			MJVISLOOP	N	N	
			COMAUD	N	N	\$
			MJALMVIS	N	N	
			MJALMAUD	N	N	
MJALMAUD1	N	N				
MJALMAUD2	N	N				
EXPILDMS	N	N				
PREFLRMJ	N	N				
SUCFLRMJ	N	N				
MJVISLOOP	N	N				
COMAUD	N	N	\$			

The following example shows datafill for table SFWALARM using functions RDTCRT, RDTMJ, RDTMN, and RDTWRN.

**MAP display examples for table SFWALARM**

FUNCTION	REPORT	ALM	SDFUNCT	ALMGRP	ALMFXR
RDTCRT	Y	CR			\$
RDTMJ	Y	MJ			\$
RDTMN	Y	MN			\$
RDTWRN	Y	NA			\$

**SFWALARM** (continued)

The following example shows datafill for table SFWALARM using function MCTALARM.

**MAP display examples for table SFWALARM**

FUNCTION	REPORT	ALM	SDFUNCT	ALMGRP	ALMFXR
MCTALARM	Y	MJ	(MJALMVIS N N)	(MJALMAUD N N)	
			(MJALMAUD1 N N)	(MJALMAUD2 N N)	
			(EXPILDMS N N)	(PREFLRMJ N N)	
			(SUCFLRMJ Y N)	(MJVISLOOP N N)	
			(COMAUD1 N N)		\$

The following example shows datafill for table SFWALARM using function SCC\_CCS\_ALM.

**MAP display examples for table SFWALARM**

FUNCTION	REPORT	ALM	LOGIC
SCC_CCS_ALM	N	NA	(SCC_CCS_ALM N N)\$

**Table history****APC009**

Added JESCALL\_ALARM and JESUNANS\_ALARM alarms to the System alarm functions table.

**CSP09**

Added SCC\_CCS\_ALM to System Alarm Functions Table.

**GL03.1**

Added MCIDALARM to System Alarm Functions Table.

**UK002**

Added MCTALARM to System Alarm Functions Table and added MCTALARM MAP display example.

**Supplementary information**

This section provides information on dump and restore procedures for table SFWALARM.

## **SFWALARM** (end)

---

### **Dump and restore**

A manual dump and restore is required. The values contained in table SFWALARM for key EMERG\_CUT\_OFF\_ON for the dumped BCS must be copied into table SFWALARM for the key EMERG\_CUT\_OFF\_ON for the restored BCS.

---

**SHADOW**

---

**Table name**

Shadow Sets Table

**Functional description**

Table SHADOW contains a description of all shadow sets defined on a DMS SuperNode switch. Feature AR0517 (Shadow Set Maintenance) allows shadow sets to be created and deleted, and their members to be added and deleted, through datafill operations.

A tuple in table SHADOW contains data for an entire shadow set. A tuple identifies

- the node
- the shadow set's name
- location of the shadow set's permanent device
- location of each of the shadow set's current members

*Note:* File management uses a shadow set's permanent device to access the shadow set.

Successful datafill operations are communicated by way of dynamic, Distributed Data Manager (DDM) downloads of the tuple of the node that houses or must house the shadow set. Datafill changes take effect on the node only after such communication has taken place. If the node is isolated, member disks can continue to be read from and written to by applications on the node until a DDM audit of or bulk download to the node.

**Datafill sequence and implications**

The following tables must be datafilled before table SHADOW:

- APINV
- FPDEVINV

**Table size**

Memory for this table is allocated dynamically.

**SHADOW** (continued)**Datafill**

Field names, subfield names, and valid data ranges for table SHADOW are described below.

**Field descriptions (Sheet 1 of 2)**

Field	Subfield or refinement	Entry	Explanation and action
NODETYPE		FP	<i>Node type</i> This field is the first of a three-part key. This field identifies the node on which the shadow set resides.
NODENO		0 to 99	<i>Node number</i> This field is the second part of a three-part key. Enter the instance number of the node identified in field NODETYPE, distinguishing one node from another of the same type. This field is applicable only to remote processors, for example, file processors (FP), since there is only one computing module (CM).
SETNAME		alphanumeric (up to 8 characters)	<i>Shadow set name</i> This field is the third of a three-part key. Enter the shadow set's name. ALL is not a valid entry for this field.
DEVTYPE		SCSIDK	<i>Device type</i> Enter the device type. The default value for this field is SCSIDK. Any entry outside the range indicated for this field is invalid.
MEMBERS		see subfields	<i>Members</i> This field consists of subfields NILPERM, PERMSCSI, and MEMSCSI.

**SHADOW** (continued)**Field descriptions (Sheet 2 of 2)**

<b>Field</b>	<b>Subfield or refinement</b>	<b>Entry</b>	<b>Explanation and action</b>
	NILPERM	0	<p><i>No permanent device</i></p> <p>If the entry in field DEVTYPE is NILDEV, enter 0 (zero).</p> <p>Any entry outside the range indicated for this field is invalid.</p>
	PERMSCSI	see refinements	<p><i>Permanent device</i></p> <p>This subfield consists of refinements SCSIBUS and DEVNO. The combination of the values of the refinements identifies the shadow set's permanent device.</p> <p>If the entry in field DEVTYPE is SCSIDK, datafill refinements SCSIBUS and DEVNO.</p>
	SCSIBUS	0 to 1	<p><i>Small computer systems interface bus</i> Enter the small computer systems interface (SCSI) bus number.</p>
	DEVNO	0 to 5	<p><i>Device number</i></p> <p>Enter the permanent device number.</p>
	MEMSCSI	see refinements	<p><i>Member</i></p> <p>This subfield consists of refinements SCSIBUS and DEVNO. The combination of the values of the refinements identifies a member of the shadow set, other than the permanent member.</p> <p>If the entry in field DEVTYPE is SCSIDK, datafill refinements SCSIBUS and DEVNO.</p>
	SCSIBUS	0 to 1	<p><i>Small computer systems interface bus</i></p> <p>Enter the SCSI bus number.</p>
	DEVNO	0 to 5	<p><i>Device number</i></p> <p>Enter the permanent device number.</p>

**Datafill example**

The following example shows sample datafill for table SHADOW.



**SHADOW** (continued)**MAP display example for table SHADOW**

NODETYPE	NODENO	SETNAME	DEVTYPE	MEMBERS
FP	0	SS00	SCSIDK 0 0	(1 0)\$
FP	2	SS00	SCSIDK 0 0	(1 0)\$
FP	4	SS00	SCSIDK 0 0	(1 0)\$
FP	4	SS01	SCSIDK 0 2	(1 2)\$
FP	6	SS00	SCSIDK 0 0	(1 0)\$
FP	6	SS01	SCSIDK 0 2	(1 2)\$
FP	8	SS00	SCSIDK 1 0	\$
FP	10	SS00	SCSIDK 0 0	(1 0)\$

**Table history**  
**CSP02**

Table SHADOW was introduced.

**Supplementary information**

This section contains information on error messages that can occur when datafilling table SHADOW.

**Deleting a node's tuple**

Deleting a node's tuple in table APINV means that shadow sets cannot exist on the node any longer. So, all shadow sets housed on that node are deleted automatically, and the following warning is displayed:

SHADOW WARNING: the node's shadow sets will be deleted!

**Changing or deleting a disk's tuple**

If a disk is a member of a shadow set as defined in table SHADOW, the following error message is displayed when an attempt is made to change or delete the disk's tuple in table FPDEVINV:

SHADOW ERROR: Disk is shadowed. First, delete it from its shadow set in table SHADOW.

**SHADOW** (end)

---

The disk must be deleted from its shadow set in table SHADOW before the disk's tuple in table FPDEVINV can be modified.

# SIGACT

---

## Table name

XPM Incoming Signal to Activity Mapping Table

## Functional description

Register signaling systems number 2 (R2) use register signaling to transfer information about a call between two ends of a trunk. The R2 systems are multi-frequency compelled (MFC) systems where the system sends tones in one direction and returns acknowledgement tones. A protocol specification describes the transferred information.

The R2 signaling applies to the DMS-100, DMS-200, and DMS-100/200 switches.

Enter each R2 activity in table SIGACT to identify the activity as a correct signal received for a protocol for each phase.

The system maintains table SIGACT in the central control (CC). The system downloads and uses table SIGACT in the extended multiprocessor system (XMS)-based peripheral module (XPM).

Each tuple contains the correct signal to activity mappings for a phase. If a signal is not correct in a specified phase, the entry of a signal does not occur. The system accesses table SIGACT each time the system receives a signal in the XPM. The system converts the signal to the activity that the signal represents.

During call processing, the SIGACT index from table R2PROT indexes Table SIGACT.

### Valid R2 activities

The correct R2 activities appear in the following table. The features that are present determine the R2 values.

#### Valid R2 activities (Sheet 1 of 7)

R2 activity	Description of activity
ACC_3_DIGS	Instructs the previous office to send an access code and 3 digits.
ACC_4_DIGS	Instructs the previous office to send an access code and 4 digits.

**SIGACT** (continued)**Valid R2 activities (Sheet 2 of 7)**

<b>R2 activity</b>	<b>Description of activity</b>
CHG_SUB_STAT	Indicates that you must interpret the following signals that the system sends back as being in group B.  <b>Note:</b> Group B signals indicate the called subscriber status.
COIN	Coin subscriber
CONNECT_CALL _CHG	Subscriber idle, charge on answer
CONNECT_CALL _NOCHG	Subscriber idle, free call
CONGESTION	Congestion in network
DATA	Data line
DIGIT_B	Priority 1 radio
DIGIT_C	z call
DIGIT_D	T call
DIGIT_E	Priority 2 cable
DIGIT_F	END_OF_DIGS, but for future expansion
DIGIT_0	Digit 0
DIGIT_1	Digit 1
DIGIT_2	Digit 2
DIGIT_3	Digit 3
DIGIT_4	Digit 4
DIGIT_5	Digit 5
DIGIT_6	Digit 6
DIGIT_7	Digit 7
DIGIT_8	Digit 8
DIGIT_9	Digit 9

**SIGACT** (continued)**Valid R2 activities (Sheet 3 of 7)**

<b>R2 activity</b>	<b>Description of activity</b>
END_OF_DIGS	End of pulsing or identification
FIRST_DIGIT	Start transmission from first digit
FREE_CALL	Free call
FREE_OR_FIXED	A free call or a fixed period call
INIT_OG_ACT	Invoked after outgoing trunk (OG TRK) seizure
INIT_IC_ACT	Invoked after incoming trunk (IC TRK) seizure
LAST_BUT_1	Backup one digit, start resending
LAST_BUT_2	Backup two digits, start resending
LAST_BUT_3	Backup three digits, start resending
LAST_DIGIT	Resend last digit
LAST_GRP	An incoming trunk sends this data backwards.
LAST_GRP1	Instructs the previous office to send the digits in the last digit group One digit expected
LAST_GRP2	Instructs the previous office to send the digits in the last digit group. Two digits expected
LAST_GRP3	Instructs the previous office to send the digits in the last digit group. Three digits expected
LAST_GRP4	Instructs the previous office to send the digits in the last digit group. Four digits expected
LAST_PTY_REL	An incoming trunk sends this signal backwards. This activity indicates to the originating office that the called subscriber line is free. This activity indicates that the operating company charges the call, and the last party release must occur. The DMS switch does not support release if Irish R2 trunks are part of this process.

**SIGACT** (continued)**Valid R2 activities (Sheet 4 of 7)**

<b>R2 activity</b>	<b>Description of activity</b>
LOCAL_COIN	<p>Calling party category. This activity informs the telephone exchange that the call originates from a local public telephone. The DMS switch does not generate this activity as an originating exchange. The DMS switch generates this activity if the activity is correct for the outgoing trunk protocol. The DMS switch can map the activity to the activity REGULAR. As a terminating exchange, the DMS switch treats this activity as REGULAR.</p> <p>For R2-ANSI (American National Standards Institute) ISDN user part (ISUP) calls, the DMS switch maps this activity to the ISUP_CPC_PAYPHONE category.</p> <p>The system does not generate this activity on NAIS ISUP-R2 calls.</p>
MTC_EQ	Maintenance equipment
MUT_CTRL_CHG	Mutual control of call by the two subscribers
NEXT_ANI_DIGIT	Send next automatic number identification (ANI) digit
NEXT_DIGIT	Send next digit
NEXT_TARIFF_DIGIT	Polish R2 register signaling. This activity requests the next tariff digit in reply to RCV_TARIFF or a group C signal. This signal is a forward group III signal.
NIL_ACT	Nil activity
NO_CALL_TRANS	An outgoing trunk sends this signal forward. This activity indicates to the destination office that the system cannot transfer the call.
OPER	Operator
OPER_ACK	Semiautomatic verification of number by operator
ORD_FIXED	Ordinary subscriber, fixed period call
ORD_DEMAND	Ordinary subscriber, demand call
ORD_HALL	Ordinary subscriber, service hall call
PBX	Call from a private branch exchange (PBX)
PR1_FIXED	Priority one subscriber, fixed period call

**SIGACT** (continued)**Valid R2 activities (Sheet 5 of 7)**

<b>R2 activity</b>	<b>Description of activity</b>
PR1_DEMAND	Priority one subscriber, demand call
PR1_HALL	Priority one subscriber, service hall call
PR1_FIXED_INTL	Priority one fixed period call, international
PR1_DEMAND_INTL	Priority one demand call, international
PR1_HALL_INTL	Priority one service hall call, international
PR1_RADIO	Priority one call, needs radio circuits
PR2_CABLE	Priority two call, needs cable circuits
PR2_FIXED	Priority two subscriber, fixed period call
PRIORITY	Priority subscriber
RCV_TARIFF	Polish R2 register signaling. This activity instructs the previous office to receive the tariff digits. The system sends this signal when the system receives enough digits to route the call. The system sends changeover of groups that takes place on RCV_TARIFF.  <b>Note:</b> Enter data in option TARIFF_LEN in table R2PROT before you change a tuple in table SIGACT to add activity RCV_TARIFF. Add a new tuple to the table to introduce this activity to the current R2 protocol.
RCV_TMO_ACT	Receive time-out activity
REGULAR	Regular subscriber
REGIONAL_6_DIGS	Indicates that the call is a national or regional call. Expect 6 digits.
REGIONAL_7_DIGS	Indicates that the call is a national or regional call. Expect 7 digits.
REQ_CAT	Request calling category
REQ_CAT_B	Change to group B and send category
REQ_CAT_C	Change to group C and send category

**SIGACT** (continued)**Valid R2 activities (Sheet 6 of 7)**

<b>R2 activity</b>	<b>Description of activity</b>
REQ_DN_CAT	Request calling directory number and category
REQ_NOT_ACC	Request not accepted
SPEECH	Set up a speech path through the office
SUB_BUSY	Subscriber line is busy
SUB_LBUSY	Called subscriber busy in a local call
SUB_TBUSY	Called subscriber busy in a toll call
SUB_OUT_ORD	Called number is out of order
SUB_XFRD	Subscriber transferred
TARIFF_0	Polish R2 register signaling. Backward group C signal. Indicates the tariff digit 0.
TARIFF_1	Polish R2 register signaling. Backward group C signal. Indicates the tariff digit 1.
TARIFF_2	Polish R2 register signaling. Backward group C signal. Indicates the tariff digit 2.
TARIFF_3	Polish R2 register signaling. Backward group C signal. Indicates the tariff digit 3.
TARIFF_4	Polish R2 register signaling. Backward group C signal. Indicates the tariff digit 4.
TARIFF_5	Polish R2 register signaling. Backward group C signal. Indicates the tariff digit 5.
TARIFF_6	Polish R2 register signaling. Backward group C signal. Indicates the tariff digit 6.
TARIFF_7	Polish R2 register signaling. Backward group C signal. Indicates the tariff digit 7.
TARIFF_8	Polish R2 register signaling. Backward group C signal. Indicates the tariff digit 8.
TARIFF_9	Polish R2 register signaling. Backward group C signal. Indicates the tariff digit 9.
TEMP_OUT_ORD	Temporarily out of order



**SIGACT** (continued)**Valid R2 activities (Sheet 7 of 7)**

<b>R2 activity</b>	<b>Description of activity</b>
TERM_CTRL_CHG	Switch to terminator call control
TOLL_AUTO	Automatic toll call
TOLL_COIN	Calling party category. This activity informs telephone exchange that the call originates from a long distance public telephone. The DMS switch does not generate this activity as an originating exchange. The DMS switch generates this activity if the activity is correct for the outgoing trunk protocol. The DMS switch can map the activity to the activity REGULAR. As a terminating exchange, the DMS switch treats this activity as REGULAR.  For R2-ANSI ISUP calls, the DMS switch maps this activity to the ISUP_CPC_PAYPHONE category.  The DMS switch does not generate this activity on NAIS ISUP-R2 calls.
TRANSIT	The first digit group indicates that the call tandems through the switch. This activity indicates that an end-to-end call must occur. This activity indicates that the next request signal must pass through from another office.
UNASSIGN_NUM	Called number is not assigned
UNIT_FEE_COIN	An outgoing trunk sends this signal forward. This activity indicates to the destination office that the call is a unit fee coin box call.

**Datafill sequence and meaning**

Enter data in the following tables after you enter data in table SIGACT.

- ACTCTL
- R2PROT, if the addition of tuple RCV\_TARIFF occurs

The system enters a number of SIGACT tuples to provide the signal-to-activity mappings for each protocol. Define one set of tuples with the same tuple number for each phase in the protocol that table R2PROT describes.

If a protocol requires a mapping entry that is already present, do not define a new tuple. More than one protocol can use SIGACT index in table R2PROT.

**SIGACT** (continued)**Table size**

0 to 4096 tuples

**Datafill**

Datafill for table SIGACT appears in the following table.

**Field descriptions**

Field	Subfield or refinement	Entry	Description
INDEX		see subfields	<i>Index.</i> This field contains subfields TUPLENO and SIGNAL which represent the index to table SIGACT.
TUPLENO		1 to 255	<i>Tuple number.</i> Enter the tuple number that corresponds to an activity that table R2PROT uses. An entry outside of this range is not correct.
SIGNAL		1 to 15	<i>Signal.</i> Enter the signal number.
ACTIVITY		alphanumeric (up to 18 characters)	<i>R2 activity.</i> Enter the name of the R2 activity. See table "Valid R2 activities" for a description of each activity.  The default value for signals not in use is NIL_ACT.

**Datafill example**

Sample datafill for table SIGACT appears in the following example.

**MAP example for table SIGACT**

INDEX		ACTIVITY
1	2	REGULAR
1	6	MTC_EQ
2	1	NEXT_DIGIT

## **SIGACT** (end)

---

### **Table history**

#### **BCS36**

Activities LOCAL\_COIN, NEXT\_TARIFF\_DIGIT, RCV\_TARIFF, TARIFF\_0 to TARIFF\_9, and TOLL\_COIN were added to table “Valid R2 activities” in BCS36.

#### **BCS34**

Table SIGACT was introduced in BCS34.

---

**SILCNWM**

---

**Table name**

Selective Incoming Load Control Table

**Functional description**

Selective incoming load control (SILC) is a network management control that makes it possible to control telephone traffic on incoming or two-way trunk groups.

Table SILCNWM identifies individual trunk groups to which SILC network management controls are applied, and defines either a percentage level or gapping interval for call blocking.

Table SILCNWM associates incoming or two-way, single stage multifrequency (MF) trunk groups with the threshold values defined in table NWMIDOC.

*Note:* Although any valid trunk group can be entered in table SILCNWM, SILC is applied only to single-stage MF trunk groups.

**Datafill sequence and implications**

Table SILCNWM is datafilled initially by telephone company personnel at installation. The table can be modified using table control.

**Table size**

0 to 8191 tuples

Allocation is based on the number of trunk groups configured in table TRKGRP.

**SILCNWM** (continued)**Datafill**

The following table lists datafill for table SILCNWM.

**Field descriptions for conditional datafill (Sheet 1 of 2)**

<b>Field</b>	<b>Subfield or refinement</b>	<b>Entry</b>	<b>Explanation and action</b>
CLLI		alphanumeric (1 to 16 characters)	<i>Common language location identifier</i> Enter the code assigned in table CLLI for the trunk group to which SILC is assigned.
SCTRL		PCT or GAP	<i>SILC control</i> Specify whether the percentage (PCT) or the gapping (GAP) value for blocking incoming trunk traffic is to be used.  PCT specifies the percentage of incoming trunk traffic to be blocked on the specified trunk group.  GAP specifies the time to be allocated between successful incoming calls on the specified trunk group (that is, the time that traffic is to be prevented from completing on the specified trunk group).

**SILCNWM** (continued)**Field descriptions for conditional datafill (Sheet 2 of 2)**

Field	Subfield or refinement	Entry	Explanation and action
LEVEL1		0 to 600	<p>Specify the percentage or gapping value to be applied to the specified trunk group based on thresholds set for LEVEL1 in table NWMIDOC.</p> <p>If PCT is specified, enter 0 to 100. GAP specifies the time that traffic is to be gapped, or prevented from completing on the specified trunk group.</p> <p>If GAP is specified, enter `0.0' to `600.0'. Because gapping values are expressed in tenths of seconds, a decimal point must be included when the values are entered in the table. In addition, single quotes must enclose the number entered (`0.1' for example, defines a gapping value of one tenth of one second).</p> <p><b>Note:</b> Gapping values must be entered between single quotation marks. However, these marks are not displayed at the MAP.</p>
LEVEL2		0 to 600	<p>Specify the percentage or gapping value to be applied to the specified trunk group based on thresholds set for LEVEL2 in table NWMIDOC.</p> <p>If PCT is specified, enter 0 to 100.</p> <p>If GAP is specified, enter `0.0' to `600.0'. As with LEVEL1 gapping values, LEVEL2 values are expressed in tenths of seconds and must include a decimal point. In addition, single quotes must enclose the values entered.</p>

**Datafill example**

An example of datafill for table SILCNWM is shown below.

The first tuple shows a trunk group with a percentage value specified.

The CLLI is MERCAMA2W. The SILC control is specified to be percentage (PCT).

## SILCNWM (end)

---

Field LEVEL1 specifies 50%.

LEVEL2 specifies 75%.

The second tuple shows a trunk group with a gapping value specified. The CLLI assigned to the trunk group is CARCAMA2W.

The SILC control to be applied is gapping (GAP).

A gapping value of 0.3 is specified for LEVEL1.

A gapping value of 600.0 is specified for LEVEL2.

### MAP display example for table SILCNWM

CLLI	SCTRL	LEVEL1	LEVEL2
MERCAMA2W	PCT	50	75
CARCAMA2W	GAP	0.3	600.00

## Supplementary information

This section provides information on datafilling table SILCNWM for specific applications, and product descriptive information related to table SILCNWM.

### Additional information

SILC is activated at the MAP. SILC controls are activated through the auto control level of the network management (NWM) subsystem of the MAP, based upon network management threshold values defined in table NWMIDOC.

Entries in table SILCNWM are retained over all restarts. In addition, entries in this table can be transferred at dump and restore.

---

**SITE**

---

**Table name***Site***Functional description**

Table SITE contains data for the DMS-100 switch and all other sites that depend on the DMS-100. Table SITE also contains the site name (SN) for each remote location. The operating company defines site names for the local sites.

The first entry in table SITE must be HOST for the host switching unit.

The test desk SN for a line equipment number (LEN) enables the testers to choose a two- or three-digit SN. This SN corresponds to the site the testers want to dial. The number 11 precedes the two-digit SN to indicate the dialing of a LEN is taking place. The number 12 precedes the three-digit SN to indicate the dialing of a LEN is taking place. Seven digits that represent the LEN come after the two- or three-digit SN. For example, 11 + 2-digit SN + 7 digits, 12 + 3-digit SN + 7 digits.

Set the module count. It must equal zero (0). The system automatically updates this value as line modules (LM) on site are added to tables LMINV and LCMINV.

The switching unit has a fixed code VER90 in table CLLI for the operator verification trunk group. The operating company defines the codes for the operator verification trunk group at the other sites. To assign these trunks to the metallic test access, refer to table MTAHORIZ. Assign these trunks in table TRKGRP with trunk group type VR.

The operating company assigns three signal distributor points at the other remote sites. The three are critical alarms, major alarms, or minor alarms. The operating company cannot assign the four remaining signal distributor points in this signal distributor group to lines for line features.

**Datafill sequence and implications**

Operating company personnel must datafill table CLLI before table SITE.

**Table size**

1 to 255 tuples

The system continuously increases table SITE in blocks of 32, as needed. At the initial program load (IPL), the system allocates data store (DS) for the first 32 tuples.



**SITE** (continued)**Datafill**

The following table lists data entries for table SITE.

**Field descriptions (Sheet 1 of 2)**

Field	Subfield or refinement	Entry	Explanation and action
NAME		alphanumeric (1 to 4 characters)	Site name. Enter the site name assigned to the host or remote switching unit. The first character must be alphabetical. Site names can be a vector of up to four characters in length. You do not use PM type names for site names. An exception is RLCM. You do not use the name ALL as a site name.
LTDSN		0 to 255	LEN test desk SN. Enter the two or three numbers required to dial the site that appears under field NAME.
MODCOUNT		0 to 1000	Module count. Enter zero (0). The system updates the value to reflect the number of line modules (LM) on site. This update proceeds as you add the LMs to tables LMINV and LCMINV.
OPVRCLLI -		VER90 or alphanumeric	Operator verification common language location identifier. Enter the common language location identifier (CLLI) assigned to the operator verification trunk group at the remote location. The host switching unit has a fixed operator verification CLLI code VER90. Enter VER90 for the switching unit operator verification CLLI.
ALMDATA		see subfields	Alarm data. This field is for remote locations only and consists of subfields ALMTYPE, TMTYPE, TMNO, CKTNO, and POINT.
	ALMTYPE	CR, MJ, MN, NA	Alarm type. If the entry is for a remote location, enter the alarm type: critical (CR), major (MJ), or minor (MN). If the entry is for the host switching unit, enter NA.
	TMTYPE	RMM, RSM, or blank	Trunk module type. If the entry is for another location, enter the trunk module type, remote service module (RSM), or remote maintenance module (RMM). This trunk module is where the signal distributor point assigned to the alarm resides. If the entry is for the host switching unit, leave blank.

**SITE** (end)**Field descriptions (Sheet 2 of 2)**

Field	Subfield or refinement	Entry	Explanation and action
	TMNO	0 to 2047	Trunk module number. If the entry is for another location, enter the number assigned to the remote service module. This module is where the signal distributor point assigned to the alarm resides. If the entry is for the host switching unit, leave blank.
	CKTNO	0 to 29 or blank	Trunk module circuit number. If the entry is for another location, enter the trunk module circuit number of the RSM or RMM. This module is where the signal distributor point assigned to the alarm resides. If the entry is for the host switching unit, leave blank.
	POINT	0 to 7 or blank	Point. If the entry is for another location, enter the signal distributor point number within the trunk module circuit number. If the entry is for the host switching unit, leave blank.

**Note:** Enter the continuation mark (+) in fields with multiple-possible entries when more data is specified on the next line or more records will be entered. Enter the end mark (\$) in fields with multiple, possible entries after the last entry.

**Datafill example**

The following example shows sample datafill for table SITE.

**MAP display example for table SITE**

NAME	LTDSN	MODCOUNT	OPVRCLLI	ALMDATA
HOST	00	14	VER90	\$
HOST	00	0	MERVON01VR90 (CR RSM 0 4 0) (MJ RSM 0 4 1)(MN RSM 0 4 2)	\$
ARCS	01	0	VER90	\$

## SLELIST

---

### Table name

Screening List Editing List Table

### Functional description

Table SLELIST is used to define the entries for every screening list editing (SLE) list in the switch. It provides information for each directory number (DN) against which screening is to be applied.

Tuples cannot be added to to SLELIST until SLE features have been assigned in table RESFEAT.

*Note:* To avoid the overhead in displaying tuples in table SLELIST, datafill SLE features through service orders (SERVORD), and not through table control. For the same reason, use Query Screening LIST (QSL) to query the screening list for a line. For more information on the QSL command, refer to the *Translations Guide*.

### Call screening services

Call screening services allow subscribers to select incoming calls by DN and route them to special treatment. Such screening services include:

- Selective Call Rejection (SCRJ) SCRJ enables a subscriber to selectively reject calls arriving from a limited set of previously identified DNs.
- Selective Call Acceptance (SCA) SCA enables a subscriber to selectively accept calls arriving from a limited set of previously identified DNs.

An exception to SCA screening is any call incoming from an operator no-test trunk, which is never subject to SCA screening.

- Selective Call Forwarding (SCF) SCF allows subscribers to define a special list of telephone numbers, called an SCF list, and a destination number. Calls that terminate on a line with this feature are forwarded only if the telephone number of the originating station matches one of the numbers in the SCF list. When a call is forwarded through the base station using SCF, an optional ring reminder can be provided using service orders.
- Distinctive Ringing/Call Waiting (DRCW) DRCW allows a subscriber to identify a list of DNs by receiving a distinctive pattern of alerting.

### Screening lists

For each call screening feature, the switch maintains a list of DNs that identify incoming calls for special treatment. These lists can be created and modified by the individual subscriber. The subscriber also has the ability to activate and deactivate the service that uses the associated screening list. Each element of

---

**SLELIST** (continued)

---

the list contains a ten-digit DN in the standard NPA-NXX-XXXX format, and a count of the number of digits actually entered by the subscriber.

The physical limit to the size of any one screening list is 8191 tuples. The actual limit can be set by the operating company for each screening service in table RESOFC. The suggested limit is 12. Adding DNs to the list through SERVORD is required for lines with Denied Termination (DOR), Automatic Line (AUL), Requested Suspension (RSUS) or any other options that deny dial tone, since the subscriber cannot access the list by using Screening List Editing.

All list entries added through SERVORD have field KIND datafilled with the value PUBLIC.

**References**

For more information on call screening refer to the *Translations Guide*.

**Datafill sequence and implications**

Table RESFEAT must be datafilled before table SLELIST.

**Table size**

The maximum number of tuples in this table depends on the size of lists assigned with each feature, and on the office parameters SLE\_MAX\_SEGMENT\_COUNT and SLE\_ITEMS\_IN\_SEGMENT.

**SLELIST** (continued)**Datafill**

The following table lists datafill for table SLELIST.

**Field descriptions for conditional datafill (Sheet 1 of 2)**

<b>Field</b>	<b>Subfield or refinement</b>	<b>Entry</b>	<b>Explanation and action</b>
LEN		see subfields	<p><i>Line equipment number</i></p> <p>This field defines the physical location of the equipment that is connected to a specific telephone line.</p> <p>Because field LEN is common to more than 60 tables, it is documented in a single section to avoid unnecessary duplication. Refer to section "Common entry field LEN" for a complete description of field LEN and associated subfields.</p> <p>For ISDN lines, field LEN consists of subfield LTID. For non-ISDN lines, field LEN consists of subfields SITE, FRAME, UNIT, DRAWER or LSG, SHELF, SLOT, and CIRCUIT.</p>
KEY		0 to 69	<p><i>Key</i></p> <p>This field contains the valid range of physical keys for a DN appearance on a Meridian Business Set (MBS). A non-MBS always has a KEY of 0.</p> <p>The default value is 0.</p>
FEAT		SCRJ SCA SCF DRCW	<p><i>Feature</i></p> <p>Enter the screening feature being added. Valid features are: SCRJ, SCA, SCF, DRCW. Entries outside this range are invalid.</p>
ENTRYNO		0 to 8191	<p><i>Entry number</i></p> <p>Enter a number between 0 and 8191. This field reflects the position of the DN within the list. Numbering always starts at 0 (zero) and counts upward by 1. This field is read-only and is ignored during writes. If the number is not the correct number for the position in the list, the switch replaces the number input with the correct number.</p>

**SLELIST** (continued)**Field descriptions for conditional datafill (Sheet 2 of 2)**

Field	Subfield or refinement	Entry	Explanation and action
NEW		Y or N	<i>Insert new tuples</i>  The entry in this field indicates that tuples may be inserted into the list at the location specified. This field is always displayed as N (no) when read. When adding tuples, enter the value Y (yes) in this field.
DN		numeric (10 digits)	<i>Directory number</i>  Enter the ten-digit number that identifies incoming calls for special treatment.
KIND		PRIVATE PUBLIC	<i>Kind of directory number</i>  Enter PRIVATE if the DN is private; that is, the DN is not voiced back during SLE list review.  Enter PUBLIC if the DN is public; that is, the DN is voiced back during SLE list review.
VBCOUNT		0 to 10	<i>Voice back count</i>  Enter the number of digits voiced back during SLE list review.  If the entry in KIND is PRIVATE, enter 0 in this field.  If the entry in KIND is PUBLIC, enter a value other than 0 in this field.
EXTN		N or Y	<i>DN added by extension command</i>  Enter Y (yes) if the DN is added by the extension command. Otherwise, enter N (no).

**Datafill example**

The following example shows sample datafill for table SLELIST.

**SLELIST** (continued)**MAP display example for table SLELIST**

LINE	KEY	FEAT	ENTRYNO	NEW	DN	KIND	VBCOUNT	EXTN
HOST 00 0 01 13	0	SCRJ	1	Y	6136213456	PUBLIC	7	N
HOST 00 0 01 13	0	SCRJ	3	Y	8196257531	PUBLIC	10	N
HOST 00 0 01 23	1	SCF	1	Y	6137335005	PRIVATE	0	
ISDN 1	1	SCF	0	Y	6136210000	PUBLIC	7	
ISDN 1	1	SCF	1	Y	6137224005	PRIVATE	7	
ISDN 1	2	SCRJ	1	Y	5196220046	PUBLIC	10	N
ISDN 1	2	SCRJ	1	Y	6137224005	PRIVATE	0	N

**Supplementary information**

This section provides information on datafilling table SLELIST for specific applications, and product descriptive information related to table SLELIST.

**Determination of the calling DN**

The calling DN is available when the call is an intraoffice call, except if the originating line is an eight- or ten-party line, where the originating DN cannot be determined. If the originating line is a two- or four-party line, the originating DN can be determined by the Automatic Number Identification (ANI) test. An ANI test is not done if the first party has the Operator Number Identification (ONI) assigned to its line.

If the call is an interoffice call, the calling DN must be made available to the terminating office by one of the following methods:

- Common Channel Signaling #7 (CCS7) ISUP - The calling number is provided in the optional calling directory number field of the address information field, in the party address parameter of the Initial Address Message (IAM).
- CCS7 Primary Rate Access (PRA) - The calling number is provided in the calling party information element of the setup message.
- Trunks supporting the Stored Program Control - Call Management Services (SPC-CMS) feature - These trunks originate from SP-1 or #1-ESS offices in the Bell Canada network. They provide the calling number in the calling party field of the calling line information message, using the CCS7 Transaction Capabilities Application Part (TCAP).

**The operation of SCRJ**

Any call which terminates to a line which is capable of being assigned SCRJ is checked for the existence of active SCRJ on the line. This check is made before checking for any other terminating feature, regardless of what state the terminating line is in. If SCRJ is active, the list is searched to determine if the

---

**SLELIST** (continued)

---

incoming call's DN appears on the list. If that is the case, the incoming call is given SCRJ treatment (announcement or tone). Answer supervision can also be provided when the call is routed to treatment. This causes the long distance caller to be charged for the call. This is specified in the SCRJ tuple of the RESOFC table.

The customer with SCRJ is not advised, in any way, that calls are being rejected.

When a call is rejected because of SCRJ, the incoming call memory slot of the called party is not updated.

When the incoming call to be screened is a forwarded call, it is the originating DN, rather than any forwarding station's DN, that is screened.

Should any failure occur during screening, screening is not applied. This is the case in the event of system failure, lack of resources, or inability to determine the calling DN.

**The operation of SCA**

Any call which terminates on a line which is assigned SCA checks for the existence of an active SCA list on the line. This check is made before checking for any other terminating feature, and regardless of what state the terminating line is in. If SCA is active, the associated list is searched to determine if the incoming call's DN appears on the list. If the DN is not on the list, the incoming call is given SCA treatment (announcement or tone). The call may optionally be provided with answer supervision when the call is routed to treatment. This causes any toll call to be charged for the call. This is specified in the SCA tuple of the RESOFC table.

The customer with SCA is not advised, in any way, that calls are being rejected.

When a call is rejected because of SCA, the Incoming Call Memory Slot of the called party is not updated.

When the incoming call to be screened is a forwarded call, the originating DN, rather than any forwarding station's DN, is used for screening.

The exception to SCA screening is any call incoming from an operator no-test trunk.



## **SLELIST** (continued)

---

An operator no-test trunk can be one of the following:

- trunks which provide operator verification functionality. Verification functionality includes suppression of terminating line feature functionality (for example, call forwarding) and suppression of hunting for termination to a hunt group member. This includes OI and VR trunk group types.
- trunk groups which carry calls from test facilities, such as a local test desk facility. These types of trunks also provide for suppression of terminating line feature functionality. This category includes VR and TD trunk group types.

These calls are not subject to SCA screening. This provides a limited capability to allow completion of emergency calls to an SCA user which are originated from a line which is not specified in the SCA list - that is, an operator will be able to complete a call to the terminating party to inform the SCA user of the emergency call.

### **The operation of SCF**

Incoming calls terminating on lines with the SCF feature check to see if SCF is currently active. If it is active the incoming DN is determined. If the incoming DN cannot be obtained, the call continues as though SCF were not present. If the DN is available, it is checked against the DNs stored in the subscriber's SCF screening list. If the DN matches one of the DNs in the screening list, the call is forwarded to the SCF forward-to-DN.

If the DN does not match, the call continues as though SCF were not present.

A ringsplash is optionally provided to the base station if the call is forwarded.

### **The operation of DRCW**

Any call which terminates to a line which has the DRCW feature assigned to it is checked for the existence of an active DRCW list on the line. If DRCW is active, an attempt is made to obtain the calling DN.

If the calling DN is available, the DRCW list of the line is checked for the matching DN. If a match is found the called station is given distinctive alerting treatment. The called station can be in one of two states:

- If the called station is idle, it is given a distinctive power ring.
- If the called station is busy, the distinctive call waiting tone is given if and only if
  - the customer has standard call waiting assigned on his/her line
  - a call can be waited

---

**SLELIST** (end)

---

If the DRCW subscriber does not take any action in receiving the waiting call by flashing or disconnecting within 10 seconds, the distinctive call waiting tone of DRCW feature is repeated once. If the called party disconnects while a call is waiting, a distinctive power ring alerts the subscriber to the call and normal call connection is established with the waiting party.

If DNs of the incoming calls cannot be identified or do not exist on the DRCW screening list, then standard alerting treatment is provided for these incoming calls.

It should be noted that Distinctive Call Waiting is the same as Call Waiting, except during alerting treatment.

## SLLNKDEV

---

### Table name

Link Device Table

### Functional description

Table SLLNKDEV specifies the characteristics of up to 64 data links used by the device connecting procedure LNKUTIL (link utility), increment CI (command interpreter). This table enables the device-connecting procedure to make use of the characteristics of the device. All devices must be datafilled in the SLLNKDEV table before they are connected in the LNKUTIL CI increment.

The directory numbers (DN) normally passed to a simplified message desk interface (SMDI) are the calling station DN and the forwarding-from station DN. Restricted DNs can be prevented from being displayed to an SMDI by using the DNSUPPR option. A restricted DN is a DN that is assigned the SUPPRESSED option in the NETNAMES, DNGRPS, or DNATTRS tables. In addition, Custom Local Area Signaling Service (CLASS) can have the CNDB (calling number delivery blocking) option assigned in the IBNLINES table, which allows an originating subscriber to control the suppression of their DN for each call.

### Datafill sequence and implications

Datafill sequence varies, depending upon the type of hardware device being used.

- The 1X89 (multiprotocol controller [MPC] card) or FX30 (input or output multiprotocol controller [IOM] card) requires the datafill in the MPC and MPCLINK tables before the datafill in the SLLNKDEV table.
- The 1X67 requires the datafill in the TERMDEV table before the datafill in the SLLNKDEV table.

### Table size

0 to 64 tuples

**SLLNKDEV** (continued)**Datafill**

The following table lists datafill for table SLLNKDEV.

**Field descriptions (Sheet 1 of 6)**

Field	Subfield	Entry	Explanation and action
DEVNAME		alphanumeric (1 to 16 characters)	<i>Device name</i> Enter the name of the device used in the LNKUTIL (link utility).
DEVTYPE		see subfield	<i>Device type</i> This field consists of subfield DEVICE.
	DEVICE	1X67, 1X89, FX30, or HS1X67	<i>Device</i> Enter the device type.  If the entry is 1X89 (multiprotocol controller [MPC] card) or FX30 (input or output multiprotocol controller [IOM] card), enter the data in the subfields MPCNO and LINKNO.  If the entry is 1X67 or HS1X67, go to the field XLATION.
	MPCNO	0 to 255	<i>Multiprotocol controller number</i> If the entry in the DEVICE field is 1X89 or FX30 enter the data in this subfield. Enter the number of the 1X89 card or FX30 card.
	LINKNO	0 to 3	<i>Multiprotocol controller link</i> If the entry in the DEVICE field is 1X89 or FX30, enter the data in this subfield. Enter the 1X89 or FX30 card link number. The 1X89 can use the link 2 or link 3 as the LINKNO. The FX30 uses link 3 only as the LINKNO.  Any entry outside the range indicated for this field is invalid.
XLATION		BCDTOASCII or NONE	<i>Translation</i> Enter the Meridian link translation used for outgoing and incoming data links.

**SLLNKDEV** (continued)

## Field descriptions (Sheet 2 of 6)

Field	Subfield	Entry	Explanation and action
PROTOCOL		NONE or X400	<i>Protocol</i> Enter the connection and the starting messages protocol for the data link and the Meridian SL-100. Also enter the leading byte information.
DIRECTION		NLK, INOUTLK, or OUTLK	<i>Direction</i> Enter the direction in which data travels through the data link.
XFERS		see subfield	<i>Transfers</i> This field consists of the subfield XFER.
	XFER	ACDRTD, MGTRPT, SMDIDATA, or SMDRRPT	<i>Transfer</i> Enter up to five report types that this data link can allow. If the data link requires less than five report types, end the list with a \$ (dollar sign).  Enter ACDRTD (Automatic Call Distribution). No subfields require an entry.  Enter MGTRPT (management report). No subfields require an entry  Enter SMDIDATA (SMDI data) and enter the subfield SMDI_OPTS.  Enter SMDRRPT (station message detail recording [SMDR] report). No subfields require an entry.  <b>Note 1:</b> The data link does not allow other types of reports if there is an entry for the ACDRTD or SMDIDATA reports on the data link.  <b>Note 2:</b> The data link can have the reports MGTRPT and SMDRRPT.
	SMDI_OPTS	see subfield	<i>Station message desk interface options</i> This field consists of the OPTION subfield.

**SLLNKDEV** (continued)

## Field descriptions (Sheet 3 of 6)

Field	Subfield	Entry	Explanation and action
	OPTION	DNSUPPR, LASTFWDN, NONMS, NMSPVT, NUMOFDIGS, SPLITNNX, COMMON, HEARTBEAT, CGNADDRDN, or XLA_ENTRY	<p><i>Option</i></p> <p>If the entry in the XFERS field is SMDIDATA, enter a maximum of ten options in this subfield. If the entry requires less than seven options, end the list with a \$ (dollar sign).</p> <p>Enter DNSUPPR (directory number [DN] suppression) and include the entries in the subfields CALLING and FWDING.</p> <p>Enter LASTFWDN (last forwarding DN). No subfields require an entry.</p> <p>Enter NONMS (no network message service [NMS]). No subfields require an entry.</p> <p>Enter NMSPVT (network message waiting service private) on a Simplified Message Desk Interface (SMDI) link. This option is a boolean expression. Enter Y, or N, for the PVT_SRC_NET subfield.</p> <p>Enter NUMOFDIGS (number of digits) and enter the data in the NUMDIGS subfield.</p> <p><b>Note:</b> If the NUMOFDIGS option is not datafilled, the DMS-100 switch sends out seven digits to the Voice Processing System (VPS).</p> <p>Enter SPLITNNX (split NNX code). No subfields require an entry.</p> <p>Enter COMMON to select a common message desk for each SMDI link. These links are used during Call Request Retrieval (CRR) and enter the data in the DESKNUM and CRRTYPE subfields.</p>

**SLLNKDEV** (continued)

Field descriptions (Sheet 4 of 6)

Field	Subfield	Entry	Explanation and action
			<p>Enter HEARTBEAT to allow the switch to respond to every SMDI heartbeat message. These messages are sent by the Voice Message System (VMS).</p> <p>Enter CGNADDRDN to allow the Address DN of the calling party to be delivered to the SMDI.</p> <p>Enter XLA_ENTRY together with any possible key to table LINEATTR. Specifies the line attributes index to enter translations for MWI.</p>
	NUMDIGS	7, 10, or VAR	<p><i>Number of digits</i></p> <p>If the entry in the OPTION subfield is NUMOFDIGS, enter the data in this subfield. Enter the number of digits in the DN that send to the Voice Message System (VMS). The entry VAR supports variable digit format.</p> <p><b>Note:</b> Before changing the number of digits in the SMDI stream, the link must be taken down.</p>
	CALLING	CONDITNL, INDIRECT, NEVER, NODIRECT, COMPCND, or COMPNODIR	<p><i>Calling directory number suppression</i></p> <p>If the entry in the OPTION subfield is DNSUPPR, enter the data in this subfield. This subfield indicates whether the calling DN is suppressed when presented to the SMDI.</p> <p>Enter CONDITNL if the calling DN is restricted.</p> <p><b>Note:</b> Entering CONDITNL in both the CALLING and FWDING fields results in neither number being shown. Also, the calling DN is supplied for all trunk types.</p> <p>Enter INDIRECT if all indirect calls are suppressed. Direct calls are unsuppressed, as no suppression checking is performed.</p>

**SLLNKDEV** (continued)

## Field descriptions (Sheet 5 of 6)

Field	Subfield	Entry	Explanation and action
			<p>Enter NEVER if the calling DN is never suppressed.</p> <p>Enter NODIRECT if all direct calls are suppressed.</p> <p>Enter COMPCND</p> <ul style="list-style-type: none"> <li>For an indirect call, the calling DN is suppressed only if the calling DN and the forwarding DN are not in the same customer group.</li> <li>For a direct call, the calling DN is delivered if the calling DN is unrestricted or if the network of the calling DN and the network of the SMDI_LINK is the same.</li> </ul> <p>Enter COMPNODIR</p> <ul style="list-style-type: none"> <li>For an indirect call, the calling DN is suppressed only if the calling DN and the forwarding DN are not in the same customer group.</li> <li>For a direct call, the calling DN is always delivered.</li> </ul>
	FWDING	CONDITNL or NEVER	<p><i>Forwarding directory number suppression</i></p> <p>If the entry in the OPTION subfield is DNSUPPR, enter the data in this subfield. This indicates whether the forwarding DN is suppressed when presented to the SMDI.</p> <p>Enter CONDITNL if the forwarding DN is restricted.</p> <p><b>Note:</b> Entering CONDITNL in both the CALLING and FWDING fields results in neither number being shown. Also, the calling DN is supplied for all trunk types.</p> <p>Enter NEVER if the forwarding DN is never suppressed.</p>



## SLLNKDEV (continued)

### Field descriptions (Sheet 6 of 6)

Field	Subfield	Entry	Explanation and action
	DESKNUM	1 to 999	<p><i>Desk number</i></p> <p>If the entry in the OPTION subfield is COMMON, enter the data in this subfield. This subfield indicates the number of the common message desk that the subscribers use when accessing CRR.</p>
	CRRTYPE	ALL or NETWORK	<p><i>Call request retrieval type</i></p> <p>This subfield specifies the type of CRR that uses the common message desk number.</p> <p>Enter ALL if all link users (host and remote) are to use the common message desk during CRR.</p> <p>Enter NETWORK if only subscribers outside the host node are to use the common message desk during CRR.</p>

### Datavill example

The following example shows sample datavill for table SLLNKDEV.

#### MAP display example for table SLLNKDEV

DEVNAME	DEVTYPE	XLATION	PROTOCOL	DIRECTION XFERS
SMDI0	FX30 0 3	NONE	NONE	INOUTLK
(SMDIDATA (COMMON 999 ALL) \$)\$				
SMDI2	1X89 1 2	NONE	NONE	INOUTLK
(SMDIDATA (NUMOFDIGS VAR) \$)\$				
SMDI3	1X67	NONE	NONE	INOUTLK
(SMDIDATA (XLA_ENTRY 10) \$)\$				

---

**SLLNKDEV** (continued)

---

Data link devices included are

- PRTO: the desired output device for Automatic Call Distribution (ACD) management reports
- VMS: a data link to a voice messaging system
- XSM: a data link to an extended system monitor card
- SMDI: a link with no network message service (NONMS)

**Table history****MMP14**

Added option XLA\_ENTRY. This defines the line attributes index for entry to translations for feature Message Waiting Indicator (MWI) over ETSI ISUP.

**NA014**

Added two suboptions for the option DNSUPPR subfield CALLING: COMPCND and COMPNODIR.

**NA013**

Added the FX30 to the DEVICE field and changed the DESKNUM subfield for the COMMON option in the SLLNKDEV table to support 999 message desks for 59010576. Added the entry VAR to the NUMOFDIG option and the NUMDIGS subfield.

**NA010**

Changed the NMSPVT option in table SLLNKDEV for AF7526, Sourcing Patches RER26, RER32, and MBR75.

**NA009**

Added HEARTBEAT and CGNADDRDN options to table SLLNKDEV.

**NA007**

Changed the Datafill Sequence and Implications section to indicate that datafill varies depending upon the hardware being used (PRS NA7F0001).

**NA004**

Added option COMMON and its subfields to SMDI\_OPTS.

**BCS36**

Added report XSMDATA to subfield XFER.

Added subfields NMSPVT and SPLITNNX to subfield OPTION.

Added entry NODIRECT to subfield CALLING.

**SLLNKDEV** (end)

---

Added note for option NUMOFDIGS.

**SLM****Table name**

System Load Module Table

**Functional description**

Table SLM indicates if the system load module has equipment or does not have equipment. If you enter data in table SLM, the system load module is active. The module contains the shelf and slot location of the SLM, along with the frame type that contains the shelf. The installation of SLM on the computing module (CM) extension shelf (CM shelf 1) for frame type computing module duplex cabinet (CMDC) occurs. The installation of the SLM can occur on CM shelf 0 for DMS Supernode SE.

Entry of data in table SLM depends on the entry of the extension shelf (CM shelf 1) in table CMSHELF for frame type CMDC. For frame type signaling connection controller (SCC), SuperNode SE combines the CM, P-side message controller (PMC) and SLM on the same shelf. This action eliminates the extension shelf.

See table CMSHELF for additional information.

**Datafill sequence and meaning**

You must enter data in table CMSHELF before you enter data in table SLM.

You must enter data in the following tables after you enter data in table SLM.

- DIRPOOL
- REXSCHED

**Table size**

0 to 2 tuples

**Datafill**

Datafill for table SLM appears in the following table.

**Field descriptions (Sheet 1 of 2)**

Field	Subfield or refinement	Entry	Description
SLMKEY		see subfield	<i>SLM key.</i> This field is the key field and contains subfield SLM.
	SLM	0 or 1	<i>System load module.</i> Enter the system load module (SLM) number.

**SLM** (end)**Field descriptions (Sheet 2 of 2)**

Field	Subfield or refinement	Entry	Description
FRTYPE		alphanumeric (a maximum of 5 characters)	<i>Frame type.</i> Enter the name of the frame type.
SHELF		0 to 3	<i>Shelf.</i> Enter the position of the shelf on the frame.
SLOT		8, 24, 7, 28	<i>Slot.</i> Enter the slot position of the SLM on the shelf. An entry that is outside the indicated range for this field is not correct.

**Datafill example**

Sample datafill for table SLM appears in the following example.

**MAP example for table SLM**

SLMKEY	FRTYPE	SHELF	SLOT
0	DPCC	1	8
1	DPCC	1	24

**Table history**  
**BCS36**

Frame type changed to reflect additional frame names.

**SLQGRP****Table name**

Single Line Queue Group

**Functional description**

Table SLQGRP is a read-only table that displays the information contained in each SLQ agent's protected data. The table is datafilled automatically when option SLQ is added to table KSETFEAT.

**Datafill sequence and implications**

Table KSETFEAT automatically datafills table SLQGRP.

**Table size**

Table size is the same as the maximum number of SLQ groups.

**Datafill**

The following table lists datafill for table SLQGRP.

**Datafilling table SLQGRP (Sheet 1 of 3)**

Field	Subfield or refinement	Entry	Explanation and action
SLQGRP		numeric	<i>Single Line Queue Group</i> This field specifies the DN to which the SLQ feature is to be assigned.
DBG		Y or N	<i>Delayed Billing</i> This field specifies whether delayed billing should start.
MAXCQSIZ		0 to 15	<i>Maximum Call Queue Size</i> This field specifies how many calls are simultaneously allowed in the queue.

**SLQGRP** (continued)

**Datafilling table SLQGRP (Sheet 2 of 3)**

Field	Subfield or refinement	Entry	Explanation and action
SLQAUDIO		Y or N	<p><i>Single Line Queue Audio</i></p> <p>This field specifies the audio group callers receive while in the queue (for example, delay announcement or music).</p> <p>Enter Y to specify the length of time before the caller hears the delay announcement. If Y is chosen, subfields RANTH and AUDIOGRP appear.</p> <p>Otherwise, enter N.</p>
	RANTH	0 or 6 to 60	<p><i>Ring time</i></p> <p>This field specifies the length of time in seconds before the caller hears the delay announcement or music. Enter the ring time.</p>
	AUDIOGRP	AUDIO1 to AUDIO512	<p><i>Audio group</i></p> <p>This field specifies the announcement from table AUDIO.</p>
OVTYPE		N, R, or D	<p><i>Overflow Type</i></p> <p>This field specifies the type of overflow. Enter R or an overflow route, D for an overflow DN, or N for none.</p> <p>If R is chosen, subfield TABID appears. If D is chosen, subfield OVDN appears.</p>
	TABID	OFRT, IBNRT4, IBNRT3, IBNRT2, IBNRTE, RRTE, TTL4, OFR4, OFR3, or OFR2	<p><i>Table ID</i></p> <p>If the entry in subfield OVTYPE is R, enter the table name to which calls are routed.</p>

**SLQGRP** (end)**Datafilling table SLQGRP (Sheet 3 of 3)**

Field	Subfield or refinement	Entry	Explanation and action
	OVDN	numeric (1 to 11 digits)	<i>Overflow directory number</i> This field specifies the number to which calls are routed.
KEYLIST		numeric	<i>Key Listing</i> This field specifies the key to which the SLQ feature is assigned.

**Datafill example for table SLQGRP**

The following example shows sample datafill for table SLQGRP.

**MAP display example for table SLQGRP**

SLQGRP	DBG	MAXCQSIZ	AUDIO	OVFLRTE	KEYLIST
7878888	N	4	N	N	( 1 )\$

**Table history****DMS100C03**

Table SLQGRP was added in DMS100C03.

**Supplementary information**

None



## SLTANIID

---

### Table name

Special Line Traffic Automatic Number Identification Table

### Functional description

Table SLTANIID contains the Special Line Traffic Automatic Number Identification (SLT ANI) codes (initially datafilled in table OSSCAT), and associates each SLT ANI code with an operator display and billing restrictions. This is done by providing an index into table RESTBIL (or DARSTBIL), which contains the actual display and billing restrictions.

No datafill sequence restrictions are enforced during datafill. However, to activate this feature, tables OSSCAT, RESTBIL, and SLTANIID must be correctly datafilled. If, for example, an SLT ANI ID is datafilled in table SLTANIID, but not in table OSSCAT, this feature will not be activated for calls which signal with that ANI ID.

Field RBILCLAS of table SLTANIID is datafilled with a Restricted Billing Class, which is normally a value that is defined by the operating company that indexes an entry in table RESTBIL. However, if a non-operating company defined class is datafilled, the default allowable billing types (all types except 'sent paid') and the default screen display (blank) are used.

### Datafill sequence and implications

There is no requirement to datafill other tables prior to table SLTANIID.

### Table size

0 to 100 tuples

**SLTANIID** (end)**Datafill**

The following table lists datafill for table SLTANIID.

**Field descriptions**

Field	Subfield or refinement	Entry	Explanation and action
SLTANI		00 to 99	Special line traffic automatic number identification. This field is an index that identifies the originating terminal type with SLT ANI codes (datafilled in table OSSCAT).
RBILCLAS		00 to 100	Restricted billing class. This field is used as an index into table RESTBIL (or DARSTBIL). It is the equivalent to field RESTBIL in table SPLND.
ONEPLUS		Y or N	One plus calls. This field indicates whether or not 1+/011+ calls from restricted phones may be treated as 1+/011+ station calls. Enter Y to indicate that these calls are allowed. Enter N to indicate that these calls are to be routed to an operator or to treatment.
SLTAMA		Y or N	Special line traffic automatic message accounting. This field is used to indicate whether or not the SLT ANI code is to be included in the Automatic Message Accounting (AMA) record.  Enter Y to record the SLT ANI code.  Enter N to exclude the SLT ANI code from the AMA record.

**Datafill example**

The following example shows sample datafill for table SLTANIID.

**MAP display example for table SLTANIID**

SLTANI	RBILCLAS	ONEPLUS	SLTAMA
15	25	Y	Y

## SNIXAPPL

---

### Table name

SuperNode UNIX Application Table

### Functional description

Table SNIXAPPL contains information for SuperNode UNIX (SNIX) application types. To run a SNIX application on a node, the entry of this table for that node with the application type and the application-specific parameters occurs. The applications use these parameters to customize the application for each node. The applications use these parameters to provide the information that the application requires.

#### To add a tuple to table SNIXAPPL

To add a tuple to table SNIXAPPL, perform the following steps:

1. Busy the node. The entry of the node must already be in table SNIXINFO.
2. Add the tuple. The entry of the file names used in the tuple must be in table SNIXVOLS. Check that the entry of the owner node that table SNIXVOLS specifies occurs in table SNIXAPPL before you use a read/write file system. Other nodes can access the read/write file system if the entry of the owner node occurs.
3. Return (RTS) the node to service.

#### To delete a tuple from table SNIXAPPL

To delete a tuple from table SNIXAPPL, perform the following steps:

1. Busy the node.
2. Delete the tuple. If the node is the owner of a read/write file system, busy the other nodes that use this file system.
3. Return the node to service.

#### To change a tuple in table SNIXAPPL

To change a tuple in table SNIXAPPL, use the following steps:

1. Busy the node.
2. Change the tuple. If the node is the owner of a read/write file system, busy the other nodes that use this file system.
3. Return the node to service.

**SNIXAPPL** (continued)**Datafill sequence and meaning**

You must enter data in the following tables before you enter data in table SNIXAPPL.

- SNIXINFO
- SNIXVOLS
- appropriate inventory tables

**Note:** Enter indexes in Automated Directory Assistance Services (ADAS) central virtual peripheral processor (VPP) application processing units (APU). These indexes must be lower than the indexes of a link peripheral processor (LPP) central APUs or local APUs. Enter indexes in LPP central APUs. These indexes must be lower than the indexes of the local APUs on the same LPP.

**Table size**

128 tuples

**Datafill**

Datafill for table SNIXAPPL appear in the following table.

**Field descriptions (Sheet 1 of 3)**

Field	Subfield or refinement	Entry	Description
INDEX		see subfield	<i>Index.</i> This field contains subfield INDEX.
	INDEX	0 to 127	<i>Index.</i> This field is the key field of the table. Enter the index.
NODETYPE		alphanumeric (a maximum of 4 characters)	<i>Node type.</i> Enter a value of the SuperNode/Unix (SNIX) node type in table SNIXINFO.  This entry is for the Automated Directory Assistance Services (ADAS), APU (application processing unit).
NODENO		0 to 1023	<i>Node number.</i> Enter a value of the SNIX node number. Enter this value in table SNIXINFO.

**SNIXAPPL** (continued)

## Field descriptions (Sheet 2 of 3)

Field	Subfield or refinement	Entry	Description
FSNMLIST		vector of a maximum of four HSDF systems	<p><i>File system name list.</i> Enter a maximum of four values for the Hosted SNIX Distributed File (HSDF) system that the SNIX application uses on this node. If less than four HSDF systems are a requirement, end the list with a \$.</p> <p>For ADAS, the system can use one load.</p>
INITFSNM		one HSDF system	<p><i>Initial file system name.</i> Enter the initialization script value for the HSDF system that the SNIX application uses to start.</p> <p>This field is optional, so you can determine the location of the initialization script.</p>
APPLDATA		see subfield	<p><i>Application data.</i> This field contains subfield APPLTYPE and refinements.</p>
	APPLTYPE	ADAS	<p><i>Application type</i> Enter ADAS for Automated Directory Assistance Services. Enter data in refinement ADAS_DATA.</p>
	ADAS_DATA	see subfield	<p><i>Automated directory assistance service data.</i> This field contains subfield APU_TYPE and refinements.</p>
	APU_TYPE	CENTRAL or LOCAL	<p><i>Application processor unit type.</i> Enter CENTRAL. Enter data in refinements CENTRAL_TYPE and CENTRAL_PEER.  Enter LOCAL. Enter data in refinement CPE_CAPACITY.</p>
	CENTRAL_TYPE	VPP or LPP	<p><i>Central application processor unit type.</i> If the entry in subfield APU_TYPE is CENTRAL, enter data in this refinement. Enter VPP for virtual peripheral processor or enter LPP for link peripheral processor.</p>

**SNIXAPPL** (end)**Field descriptions (Sheet 3 of 3)**

Field	Subfield or refinement	Entry	Description
	CENTRAL_ PEER	0 to 1024	<i>Central peer number.</i> If the entry in subfield APU_TYPE is CENTRAL, enter data in this refinement. Enter the central peer number.
	CPE_ CAPACITY	0 to 100	<i>Central peer capacity.</i> If the entry in subfield APU_TYPE is LOCAL, enter data in this refinement. Enter the central peer capacity. The peer capacity is the maximum number of call processing channels that the APU can handle at one time.

**Datafill example**

Sample datafill for table SNIXAPPL appears in the following example.

**MAP example for table SNIXAPPL**

INDEX	NODETYPE	NODENO	FSNMLIST	INITFSNM	APPLTYPE	APPLDATA
0	APU	4	\$	\$	ADAS CENTRAL VPP	33

**Table history****CSP02**

The ISN entry in subfield APPLTYPE was removed in CSP02. Refinement PEER\_NODENO was removed in CSP02. The ISN was removed from the datafill example in CSP02.

**BCS36**

A statement about the entry of APUs was added to "Datafill sequence" section in BCS36. Entry COVM was changed to ISN in subfield APPLTYPE in BCS36. Additional information was added to field CPE\_CAPACITY in BCS36.

**BCS35**

Table SNIXAPPL was introduced in BCS35.

## SNIXINFO

---

### Table name

SuperNode UNIX Configuration Data Table

### Functional description

Table SNIXINFO contains configuration data for nodes that run SuperNode/UNIX (SNIX). Two categories of data in this table are base data and node data. The base data applies to every SNIX node. The node data applies to specified node types.

Entry of a node in this table is not a requirement for running SNIX. Note the following information:

- The system assumes default values of the fields for the node. As of BCS35, field RSTNUM is the only field that applies to the application processor (AP) and the file processor (FP). The default value is 3.
- The node is not usable. You cannot configure applications on the node unless the node is present in table SNIXINFO. See table SNIXAPPL.
- The node does not use the Hosted SNIX Distributed File (HSDF) System feature.

### Adding a tuple to table SNIXINFO

To add a tuple to table SNIXINFO, perform the following steps:

1. Busy the node from the MAP (maintenance and administration position). Do not busy the node if the node is already in manual busy (MBSY) or offline (OFFL) state. When the step states that the node is busied, the system stops the applications that run on the node. Enter the node in the inventory table to run the SNIX load. See table LIUINV for node application processing unit (APU). See table APINV for nodes AP and FP.
2. Add the tuple.
3. Configure HSDF and applications on this node through tables SNIXVOLS and SNIXAPPL.
4. Return to service (RTS) the node. Perform LOADPM if you did not load the SNIX load already.

**SNIXINFO** (continued)**Deleting a tuple from table SNIXINFO**

To delete a tuple from table SNIXINFO, perform the following steps:

1. Remove references to the node that you delete from tables SNIXVOLS and SNIXAPPL.
2. Busy the node.
3. Delete the tuple.

**Change tuple in table SNIXINFO**

To change a tuple in table SNIXINFO, perform the following steps:

1. If changes to the other fields for the same node occur, perform the following steps:
  - a. Busy the node.
  - b. Change the tuple.
  - c. Return the node to service.

**Datafill sequence and meaning**

Enter data in the following tables before you enter data in table SNIXINFO.

- LIUVN
- APINV

Enter data in table SNIXAPPL after you enter data in table SNIXINFO.

**Table size**

128 tuples

**Datafill**

Datafill for table SNIXINFO appears in the following table.

**Field descriptions (Sheet 1 of 2)**

Field	Subfield or refinement	Entry	Description
INDEX		see subfield	<i>Index.</i> This field contains subfield INDEX. This field is the key field of the table.
	INDEX	0 to 127	<i>Index.</i> Enter the index.



## SNIXINFO (continued)

### Field descriptions (Sheet 2 of 2)

Field	Subfield or refinement	Entry	Description
NODEDATA		see subfield	<i>Node data.</i> This field contains the subfield NODETYPE and NODENO.
	NODETYPE	AP, APU, or FP	<i>Node type.</i> Enter the node type.  Enter AP for application processor.  Enter APU for automated processing unit.  Enter FP for file processor.  The system uses this field as the selector for the rest of the node data.  Entries outside the specified range for this field is not correct.
	NODENO	0 to 1023	<i>Node number.</i> Enter the node number to identify a specified node of a node type from the previous field.
RSTNUM		1 to 10	<i>Number of SNIX restarts.</i> If the entry in subfield NODETYPE is AP or FP, enter data in this refinement. Enter the maximum number of restarts that can occur in a fixed time period.

### Datfill example

Sample datfill for table SNIXINFO appears in the following example.

### MAP example for table SNIXINFO

INDEX	NODEDATA
1	APU 3

### Table history

#### BCS35

Table SNIXINFO was introduced in BCS35.

**Additional information**

This section provides information on dump and restore procedures when you enter data in table SNIXINFO.

**Dump and restore**

A dump and restore procedure is not a requirement for the first application. Normal dump and restore procedures apply after the first application.

## SNIXVOLS

---

### Table name

SuperNode UNIX Disk Volumes Table

### Functional description

Table SNIXVOLS contains the configuration data for the Hosted SuperNode UNIX (SNIX) Distributed File System (HSDF) and for SNIX applications. This data allows you to create and mount the Support Operating System (SOS) files in table SNIXVOLS. You can mount the SOS files like SNIX file systems. The SNIX applications access these file systems at a file system level, not at the SOS file level.

The files that you enter in table SNIXVOLS are SOS files that reside on the computing module (CM) disk. The SNIX side of the SNIX nodes as SNIX file systems accesses these files.

Enter data in Table SNIXVOLS if SNIX nodes require access to the HSDF systems on the CM disks.

### Adding a tuple to table SNIXVOLS

To add a tuple to table SNIXVOLS, perform the following steps:

1. Read/write only. The owner node must be in table SNIXINFO.
2. Add the tuple. File names that the tuple specifies must already be copied to the CM disk. You can choose shadowing on each file system. If you desire shadowing, specify two file locations with identical images and the same internal states in field FSLIST.
3. Add the file system to table SNIXAPPL.

### Deleting a tuple from table SNIXVOLS

To delete a tuple from table SNIXVOLS, perform the following steps:

1. Remove references to the file system name in table SNIXAPPL after you busy the node.
2. An application processor unit (APU) must not be using the file system. If you delete a tuple while the tuple is in use, the system leaves the tuple in an inconsistent state. You cannot add the tuple to table SNIXVOLS as a read-only file system.

### Changing a tuple in table SNIXVOLS

To change a tuple in table SNIXVOLS, perform the following steps:

1. The system changes files of the read-only file system if the new files are the same as the old files. If the new file is not the same, the system

---

**SNIXVOLS** (continued)

---

assumes that a software upgrade occurred. The system restarts the APUs that use the file system. The system begins the restart.

2. The system cannot change files of a read/write file system if you do not remove the good file. If the two files in a duplex file system are good, the change cannot remove the two files.

**Datafill sequence and meaning**

Enter data in the following tables before you enter data in table SNIXVOLS.

- SNIXINFO
- SNIXVOLS
- appropriate inventory tables

If a reference to a SNIX node in a tuple occurs, enter the tuple in table SNIXINFO and the corresponding inventory table. For example, SNIX node type APU uses inventory table LIUINV, SNIX node types AP and FP use inventory table APINV.

Before you add a tuple to table SNIXVOLS, copy the file (field FILENAME) to the CM disk in the volume (field VOLUME). You can enter files on the system load module (SLM) or the input/output controller (IOC) disk only in this table. You cannot enter files on devices other than the SLM or IOC in this table.

Table SNIXAPPL can refer to the file systems present in table SNIXVOLS. When this condition applies, enter data in table SNIXVOLS before you enter data in table SNIXAPPL. Entry of data in table SNIXAPPL after table SNIXVOLS is optional.

**Table size**

16 tuples

**SNIXVOLS** (continued)**Datafill**

Datafill for table SNIXVOLS appears in the following table.

**Field descriptions (Sheet 1 of 2)**

Field	Subfield or refinement	Entry	Explanation and action
FSNUM		see subfield	<i>File system number.</i> This field contains subfield KEY_SNIXVOLS. This field is the key field of the table.
	KEY_SNIXVOLS	0 to 15	<i>SuperNode UNIX volumes.</i> Enter the file system number that represents the SOS file on the CM disk.
FSNAME		alphanumeric (a maximum of 14 characters)	<i>File system name.</i> Enter the file system name.
FSLIST		see subfields	<i>File system list .</i> This field contains a maximum of two multiples of subfields FILENAME and VOLUME. If less than two locations are a requirement, end the list with a \$ (dollar sign).
	FILENAME	alphanumeric (a maximum of 32 characters)	<i>SOS filename.</i> Enter the SOS filename of a copy of the HSDF system.
	VOLUME	alphanumeric (up to 16 characters)	<i>Computing module disk volume.</i> Enter the disk volume that contains the SOS file that the SOS filename (field FILENAME) identifies.
ACCMINFO		see subfield	<i>Access mode info.</i> Field ACCMINFO contains subfield ACCMODE and refinements.
	ACCMODE	RO or RW	<i>Access mode.</i> Enter RO for read only. Other datafill is not a requirement.  Enter RW for read/write. Enter data in refinements OWNRRDATA, NODETYPE, and NODENO.

**SNIXVOLS** (continued)**Field descriptions (Sheet 2 of 2)**

Field	Subfield or refinement	Entry	Explanation and action
	OWNRDATA	see subfields	<i>Owner node.</i> If the entry in subfield ACCMODE is RW, enter data in this refinement. This refinement contains subfields NODETYPE and NODENO.
	NODETYPE	AP, APU, or FP	<i>Node type.</i> Enter the value for the node type. The nodes configured in the specified office determine the values.  This entry must be the same as field NODETYPE in table SNIXINFO.
	NODENO	0 to 1023	<i>Node number.</i> Enter the node number of the SNIX node. This entry must be the same as field NODENO in table SNIXINFO.

**Datafill example**

Sample datafill for table SNIXVOLS appears in the following example.

**MAP example for table SNIXVOLS**

FSNUM	FSNAME	FSLIST ACCMINFO
0	ADASLOAD	(AD35AA S00DSNIX) \$ RW APU 0

**Table history****BCS35**

Table SNIXVOLS was introduced in BCS35.

**Additional information**

This section provides information on how to activate table SNIXVOLS after you enter data.

## **SNIXVOLS** (end)

---

### **Activation**

You must enter data in table SNIXVOLS to use the HSDF functionality.

Changes to table SNIXVOLS are immediate. On nodes with a read/write file system, this file system is available when you bring the owner node to service. When you make a change to a tuple in table SNIXVOLS, the HSDF processes the change internally. If internal software does not process the change, another tuple change cannot occur.

---

**SNPANAME**

---

**Table name**

Serving Numbering Plan Area Name Table

**Functional description**

Table SNPANAME allows the operating company to define a maximum of 127 variable-length serving numbering plan areas (SNPA).

Office parameter MAXSTS in table OFCENG sets the maximum number of SNPAs.

**Datafill sequence and meaning**

Enter data in the following tables after you enter data in table SNPANAME.

- HNPACONT
- TOFCNAME
- TRKGRP
- LINEATTR
- HUNTGRP

**Datafill guidelines**

If you load module ICOEXTK, the office is a coexistence office. This office allows the same three-digit numbering plan area (NPA) code for North American and international directory numbers. In an international office, table SNPANAME defines this area code.

Enter data in Table SNPANAME before you enter data in table HNPACONT. If you add a tuple to HNPACONT first, and field SNPA contains Y, the system updates SNPANAME with the same tuple.

If you add a three-digit tuple to SNPANAME, you can assign a serving translation scheme (STS) to this table. To add an STS, add the same code to HNPACONT, and field SNPA must contain Y.

When you delete an area code from SNPANAME, the corresponding STS entry disappears from HNPACONT. The system preserves route and code references against the STS. These references become available when you add a new three-digit SNPA. False bottoms are not introduced to HNPACONT.

When you enter an STS and field SNPA contains Y from HNPACONT, the system does not delete the equivalent entry in SNPANAME.



## SNPANAME (end)

---

### Table size

0 to 127 tuples

### Datafill

Datafill for table SNPANAME appears in the following table.

### Field descriptions

Field	Subfield or refinement	Entry	Description
KEY		0 to 9 and A to F (vector of a maximum of seven entries)	Key. Enter the SNPA code for the switch.

### Datafill example

Sample datafill for table SNPANAME appears in the following example.

### MAP example for table SNPANAME

KEY
51
52

**SNVLGRP****Table name**

Operator Services System Advanced Intelligent Network (OSSAIN) Service Node (SN) Voice Link Group

**Functional description**

Table SNVLGRP defines a voice link for a function on a service node. This distinction is necessary since each SN may serve multiple functions and multiple SNs may serve the same function. This table is used by the switch to select a voice link for an SN.

**Datafill sequence and meaning**

There is no requirement to enter datafill into other tables before table SNVLGRP.

Enter datafill into tables OANODINV, OAFUNDEF, and CLLI before table SNVLGRP.

**Table size**

0 to 785,664 tuples

**Datafill**

The table that follows lists datafill for table SNVLGRP.

**Field descriptions (Sheet 1 of 2)**

Field	Subfield	Entry	Explanation and action
NODEFUNC		see subfields	Node name and function. This field is the key to the table and consists of subfields NODENAME and FUNCNAME.
	NODENAME	name from table OANODINV	Node name. This field specifies the service node name from table OANODINV for this voice link group. The node must be datafilled in table OANODINV as a PM type of OSNM.

**SNVLGRP** (continued)

## Field descriptions (Sheet 2 of 2)

Field	Subfield	Entry	Explanation and action
CLLI	FUNCNAME	name from table OAFUNDEF	Function name. This field specifies the function name from table OAFUNDEF for this voice link group. The function must be datafilled in table OAFUNDEF as an SN function with field CAMHERE = Y.
		name from table CLLI	<p>Common language location identifier. This field identifies the voice link group to use when making the SN voice link selection and connection for the service node and function pair. The switch uses the most idle selection sequence for selecting a voice link member from the group.</p> <p>The requirements for this CLLI are as follows:</p> <ul style="list-style-type: none"> <li>• The CLLI must be datafilled in tables CLLI and TRKGRP.</li> <li>• The CLLI must be datafilled in table TRKGRP as <ul style="list-style-type: none"> <li>— GRPTYP = TOPSVL (group type)</li> <li>— DIR = OG (direction is outgoing)</li> <li>— SELSEQ = MIDL (selection sequence is most idle)</li> </ul> </li> <li>• The CLLI must be datafilled in table TRKSGRP as follows: <ul style="list-style-type: none"> <li>— DIR = OG (direction is outgoing)</li> <li>— OPULSTYP = NP (Outgoing type of pulsing is no pulse)</li> <li>— OSTARTSG = IM (outgoing start dial signal is immediate)</li> <li>— REMBSY = Y (remote make busy is enabled)</li> </ul> </li> <li>• The CLLI cannot be an existing OSAC host-remote voice link datafilled in table OSCVLGRP or SN voice link datafilled in table OAVLMAP.</li> </ul>

**Datafill example**

The figure that follows shows sample datafill for table SNVLGRP.

**SNVLGRP** (continued)**MAP display example for table SNVLGRP**

NODEFUNC		CLLI
SN_A	CLG_CARD	VL_1
SN_A	OTHR_SVS	VL_2
SN_B	CLG_CARD	VL_1

**Error messages for table SNVLGRP**

The following error messages apply to table SNVLGRP.

**Error messages for table SNVLGRP (Sheet 1 of 2)**

Error message	Explanation and action
The node for the voice link must be first datafilled in table OANODINV.	Table OANODINV must be datafilled with the node name before being used in table SNVLGRP. This error message is displayed if the node name is not datafilled in table OANODINV.
Only node ids of PM type OSNM can be datafilled in this table.	The node name must be datafilled as an OSNM switch. This error reason is displayed if the node name is not datafilled in table OANODINV as an OSNM switch.
Only SN functions can be datafilled in this table.	Table OAFUNDEF must be datafilled with the function name before being used in table SNVLGRP. The function name must be datafilled as a SN function with CAMHERE filed set to Y. This error reason is displayed if the function name is not datafilled as a SN function.
Only SN functions with the CAMHERE field set to Y can be datafilled in this table.	This error message is displayed if the function name is not datafilled as an SN function with the CAMHERE field set to Y.
This CLLI must be datafilled in Table TRKGRP before datafilling this table.	The CLLI must be datafilled in table TRKGRP before being used in this table. This error message is displayed if it is not datafilled in table TRKGRP.
Trunk group type for CLLI must be TOPSVL.	The trunk group type for the CLLI must be TOPSVL. This error message is displayed if the trunk group is of another type.

---

## SNVLGRP (end)

---

### Error messages for table SNVLGRP (Sheet 2 of 2)

Error message	Explanation and action
The TOPSVL trunk group circuit must be datafilled as outgoing in table TRKSGRP.	The voice link trunk group circuit must be datafilled as outgoing in table TRKSGRP. This error message is displayed if the voice link trunk group circuit is not datafilled as outgoing in table TRKSGRP.
The CLLI name is used in table XXXXXXXX, it cannot be reused here.	Existing OSAC host-remote voice links datafilled in table OSCVLGRP or SN voice links datafilled in table OAVLMAP can not be reused in table SNVLGRP. This error message is displayed when attempting to datafill table SNVLGRP with a voice link that is used in table OSCVLGRP or OAVLMAP.  In the error message, XXXXXXXX is the name of the table containing the CLLI.

### Table history

#### TOPS11

This table was created by feature AF7714 in functionality OSSAIN 11 Enhancements, OSAN0006.

---

**SOFTKEY**

---

**Table name**

Softkey Table

**Functional description**

Table SOFTKEY specifies softkey information for application services. The index into table SOFTKEY is an application service identifier (ID) and a softkey definer number. The data fields include a long label string, short label string, and return string for the corresponding softkey definer.

Default datafill is added to table SOFTKEY when the Call Logging feature package is present in the load. Only the default tuples in fields LLABEL and SLABEL can be changed. The return strings are hard coded and cannot be changed. The return strings in the default tuples are the only return strings that are recognized by the Call Logging application software.

The top (TOP) softkey is automatically associated with the down scroll key of the last item on the virtual display. The bottom (BOTTOM) softkey is automatically associated with the up scroll key of the header item. The top and bottom softkeys can be associated with any standard logical phrase in table TEXTLOG. (These keys are only different because they are automatically associated with the scroll keys.)

**Note:** Entries in table SOFTKEY are referenced by table TEXTLOG.

The soft key return string is a sequential list of actions (sending DTMF tones or flashing, etc.) which is performed by the CPE when the corresponding soft key is pressed. The soft key return string is sent to the CPE as a combination of data characters, encoded in the currently active character set, and 1 byte binary control codes. The return string can contain the binary codes for CPE control shown in the following table.

**Return string control codes (Sheet 1 of 3)**

NameDTMF	Hexadecimal Default	DecimalDefault	MeaningTransmit the characters using DTMF
Encoded DTMF	80	128	Transmit the following characters using DTMF encoded
On hook	81	129	Open switch-hook
Off hook	82	130	Close switch-hook
Flash	83	131	Flash switch-hook

**SOFTKEY** (continued)**Return string control codes (Sheet 2 of 3)**

<b>NameDTMF</b>	<b>Hexadecimal Default</b>	<b>DecimalDefault</b>	<b>MeaningTransmit the characters using DTMF</b>
Dial Tone Detect	84	132	Wait for detection of dial tone
Line Number	85	133	Returns the current line number using DTMF/encoded
Blank	86	134	Does not return anything
Send Characters	87	135	Send the characters/digits that have been collected
Clear Characters	88	136	Clear the characters/digits that have been collected
Backspace	89	137	Erase the last character that was collected
Tab Field	8A	138	Tab the current line to the following subfield
Goto Line	8B	139	Goto the following page and line number
Goto Line Relative	8C	140	Up/down the number of lines relative to the current line
Page Up	8D	141	Go up one page
Page down	8E	142	Go down one page
Extended DTMF	8F	143	Send the DTMF tones for 250 +- 5ms instead of 60
Delay	90	144	Delay for a specified period, in 10 ms units
Dial Pulse One	91	145	Send a dial pulse one
Switch to Data	92	146	Switches the CPE to Data mode
Switch to Voice	93	147	Switches the CPE to Voice mode
Display Call Buffer n	94	148	Display the specified Call buffer
Clear Call Buffer n	95	149	Clear the specified Call buffer
Enable/Disable Flags	96	150	Enable/Disable Information flags
Clear Display	97	151	Clear the CPE physical display

**SOFTKEY** (continued)**Return string control codes (Sheet 3 of 3)**

<b>NameDTMF</b>	<b>Hexadecimal Default</b>	<b>DecimalDefault</b>	<b>MeaningTransmit the characters using DTMF</b>
Display String	98	152	Display a predefined string/information identified next
Soft Key	99	153	Display a particular script soft key identified next
State Change	9A	154	Change the state of a service script to a new state
Start/clear Timer	9B	155	Start/stop a timer
Flag on/off	9C	156	Turn a flag of service script on/off
Overlay	9D	157	Overlay the specified sub-script
Event 22 Trigger	9E	158	Trigger an occurrence of event 22
Event 23 Trigger	9F	159	Trigger an occurrence of event 23
Exit	A0	160	Exit the service script interpreter

Return string control codes from x(98) through x(A0) are reserved for use by CPE-resident features. Return string control codes from x(A1) through x(FE) are also reserved for future use. The octet x(FF) is reserved as a delimiter in the "Load Soft Key Table" and "Load CPE Script Soft Key Table" protocol parameters and so cannot act as a return string control code.

**Datafill sequence and implications**

There is no requirement to datafill other tables prior to table SOFTKEY.

For initial datafill, a set of default datafill is provided for each service.

Field RETURN cannot be changed for applications VSLE and CALLOG. The tuples for these application service IDs cannot be deleted.

**Table size**

0 to 224 tuples



**SOFTKEY** (continued)**Datafill**

The following table lists datafill for table SOFTKEY.

**Field descriptions**

Field	Subfield or refinement	Entry	Explanation and action
SERVID		CALLOG, VSLE	<i>Service identifier</i> This field, together with field DEFNUM, is the index into table SOFTKEY. Enter a character string that corresponds to a specific application. Up to seven application service identifiers can be specified.
DEFNUM		2 to 99	<i>Defining numbers</i> Enter a number to identify a softkey definer for use with the specified application. Up to 32 softkey definers can be defined within each application.
LLABEL		alphanumeric (1 to 18 characters)	<i>Label</i> Enter the label that appears on the customer premise equipment (CPE) set display on the line above the softkeys.
SLABEL		alphanumeric (1 to 7 characters)	<i>Subset of label</i> Enter a string of characters corresponding to the characters in the long label that are not optional. These characters are displayed on CPE sets that are not equipped to display long labels.
RETURN		0 to 255 (vector of up to 14 values)	<i>Return</i> This field is a vector of up to 14 numeric values, representing the decimal equivalents of alphanumeric characters or return string codes.
LINKAGE (-NA002)		1 to 33	<i>Linkage</i> Enter a vector of up to seven definer numbers. If less than seven numbers are required, end the list with a \$ (dollar sign). The labels of the softkey definers datafilled here are the labels that are displayed when the corresponding softkey is pressed. If all seven softkey definer numbers are not datafilled, the remaining definers are set to 1 by the CPE set.

**Datafill example**

The following example shows sample datafill for table SOFTKEY.

**SOFTKEY** (end)**MAP display example for table SOFTKEY**

SERVID	DEFNUM	LLABEL	SLABEL	RETURN
CPESERV	10	ON_HOOK	ONHK	129 \$
CPESERV	11	FLASH	FLS	131 \$
CPESERV	12	BACKSPACE	BACK	137 \$
CPESERV	13	TAB_FIELD	TAB	138 \$
CPESERV	14	DIAL_PULSE ONE	DP1	145 \$
CPESERV	15	CLEAR_DISPLAY	CDSP	151 \$
CPESERV	16	OVERLAY	OVRLY	157 \$
CALLOG	2	UNDO	UNDO	50 \$
CALLOG	4	TOP	TOP	\$
CALLOG	5	BOTTOM	BOT	\$
CALLOG	7	REMOVE	REM	55 133 \$
CALLOG	8	DIAL	DIAL	56 133 \$

**Table history****EUR006**

Corrected maximum table size.

**NA004**

The tuple DSCWID was removed from table SOFTKEY.

**NA002**

The following changes were made to table SOFTKEY:

- changed valid entries and explanation for field RETURN
- changed valid entries for field SERVID
- deleted field LINKAGE
- changed valid entry character string length for field LLABEL
- changed valid entry character string length for field SLABEL and deleted reference stating that entry in field SLABEL must be a subset of field LLABEL

## SORLIST

---

### Table name

Station Origination Restrictions List Table

### Functional description

Table SORLIST stores the maximum number of station origination restriction (SOR) groups for each customer group. Table SORLIST also contains the exception list of calls allowed by SOR levels 1 and 3.

The SOR levels can be applied to directory numbers (DN) or groups of DNs by attendants if the SORC option is applied to an attendant console key in table FNMAP. The SOR levels can be applied to DNs or groups of DNs by subscribers if the SORC option is applied to the DN of the subscriber in table IBNLINES or table KSETLINE.

To create a SOR group, the SOR option must be applied against an Integrated Business Network (IBN) line in table IBNFEAT or against a business set in table KSETFEAT.

A level 0 restriction permits all calls allowed by the network class of service (NCOS) to complete. A level 1 restriction permits only intragroup calls and calls specified in an exception list to complete. A level 2 restriction permits only the intragroup calls to complete. A level 3 restriction permits only calls specified in an exception list to complete. A level 4 restriction permits only 911 emergency calls to complete.

### Datafill sequence and implications

Table CUSTSTN must be datafilled before table SORLIST.

The SOR must first be datafilled in table CUSTSTN before table SORLIST can be datafilled.

### Table size

0 to 4095 tuples

Every tuple in this table uses 22 words of protected data store.

**SORLIST** (end)**Datafill**

The following table lists datafill for table SORLIST.

**Field descriptions**

Field	Subfield or refinement	Entry	Explanation and action
CUSTNAME		alphanumeric (1 to 16 characters)	<i>Customer group name</i> Enter the name assigned to the customer group.
NUMGRPS		1 to 64	<i>Number of groups</i> Enter the number of station origination restriction (SOR) groups desired for the customer group.
EXCPTLST		numeric (1 to 11 digits)	<i>Exception list</i> Enter the numbers that are called despite the application of a station origination restriction level of 1 or 3 against the line. Up to five numbers can be datafilled. If less than five numbers are required, end the list with a \$ (dollar sign).

**Datafill example**

The following example shows sample datafill for table SORLIST.

In the example, the LONS632B customer group can have up to twelve SOR groups. The exception list for the lines that have an origination restriction level of 1 or 3 applied against them consists of 0, 911, and 96211234. The numbers in the exception list are the only numbers that can be called by lines with the 1 or 3 restriction level.

**MAP display example for table SORLIST**

CUSTNAME	NUMGRPS	EXCPTLST
LONS632B	12	( 0 ) ( 911 ) ( 96211234 )\$

## SPCCON

---

### Table name

Semipermanent connections connection table

### Functional description

Table SPCCON allows operating company personnel to define semipermanent connections (SPC) through datafill.

An SPC is a connection that can be set up or taken down by operating company personnel. The subscriber has no control over the SPC set-up or take-down, but does have the use of the speech and data path provided for the duration of the connection.

Table SPCCON defines the following types of connections:

- line to line
- line to trunk
- trunk to line
- trunk to trunk
- line on international remote line concentrating module (IRLCM) to line on IRLCM
- line to line on IRLCM
- line on IRLCM to line
- trunk to line on IRLCM
- line on IRLCM to trunk

*Note:* All the agents defined in this list are on the host, with the exception of the agents on the IRLCM.

The following datafill is required to define an SPC:

- Lines are identified as SPC agents by their line class code (LCC) and line equipment number (LEN).
- Trunks are identified by their group type, SPC, their common language location identifier (CLLI), and member number.
- Table SPCCON is datafilled with the two SPC agents previously identified, and a Y (yes) is entered in field CONNECT to indicate that the connection is required immediately.

A background audit runs approximately every 10 minutes and provides a mechanism to maintain SPCs. To produce an SPC, prospective trunk agents

---

**SPCCON** (continued)

---

must be in an idle state to make a connection. Line agents can be in a call processing busy (CPB), permanent lockout (PLO), call processing deload (CPD), or delete (DEL) state. Field CONNECT in table SPCCON must be set to Y. To take down a connection, field CONNECT must be set to N (no).

All SPC connections remain up during warm restarts. For reload and cold restarts, the connections are reconstructed immediately after the restart is complete. SPC connections are also reconstructed quickly after XPM SWACTS.

*Note:* In the case of SPC connections, all nodes remain stable over warm restarts except for the Offshore Remote Cluster Controller (RC02) node.

SPC connections use nailed-up connections through the network. Therefore, the maximum number of active SPC connections allowed at one time is determined by office parameter MAXNUCS. The value of this parameter is the maximum allowable number of all nailed-up network connections.

SPC connections cannot be intraswitched; this must be taken into account in traffic studies.

### **Datafill sequence and implications**

To define a line as type SPC, datafill tables LINEATTR, LCCOPT, and LENLINES before table SPCCON.

To define a trunk as type SPC, datafill tables CLLI, TRKGRP, TRKSGRP, and TRKMEM before table SPCCON.

### **Table size**

0 to 1200 tuples. Table SPCCON provides space for 1200 tuples at the time of initial program load (IPL).

**SPCCON** (continued)**Datafill**

The following table lists datafill for table SPCCON.

**Field descriptions (Sheet 1 of 3)**

Field	Subfield or refinement	Entry	Explanation and action
SPCKEY		alphanumeric (1 to 16 characters)	<i>Semipermanent connections key</i> Enter a string that is used as the table key.
AGENT1		see subfield	<i>Agent one</i> Agent one represents one of the two agents in the semipermanent connection (SPC). This field consists of subfield AGNTYPE.
	AGNTYPE	LINE or TRK	<i>Agent type</i> Enter LINE if the agent one in an SPC is a line and datafill refinement LINE_AGENT.  Enter TRK if the agent one in an SPC is a trunk and datafill refinements CLLI and EXTRKNM.
	LINE_AGENT	see subfields	<i>Line agent</i> If the entry in subfield AGNTYPE is LINE, datafill this refinement. This field is similar to field LEN in other tables. Refer to the field LEN description as follows.  This field defines the physical location of the equipment that is connected to a specific telephone line.  Because field LEN is common to more than 60 tables, it is documented in a single section to avoid unnecessary duplication. Refer to section "Common entry field LEN" for a complete description of field LEN and associated subfields.  Field LEN consists of subfields SITE, FRAME, UNIT, DRAWER or LSG, SHELF, SLOT, and CIRCUIT.  <b>Note:</b> Only enhanced line concentrating modules (LCME) and international remote line concentrating modules (IRLCM) can be datafilled.

**SPCCON** (continued)

## Field descriptions (Sheet 2 of 3)

Field	Subfield or refinement	Entry	Explanation and action
AGENT2	CLLI	alphanumeric (1 to 16 characters)	<i>Common language location identifier</i> If the entry in subfield AGNTYPE is TRK, datafill this refinement. Enter the code assigned in table CLLI to the trunk that is agent one in the SPC.
	EXTRKNM	0 to 9999	<i>External trunk number</i> If the entry in subfield AGNTYPE is TRK, datafill this refinement. Enter the external trunk number assigned to the trunk that is agent one in the SPC.
		see subfield	<i>Agent two</i> Agent two represents the second of the two agents in the SPC. This field consists of subfield AGNTYPE.
	AGNTYPE	LINE or TRK	<i>Agent type</i> Enter LINE if the agent two in an SPC is a line and datafill refinement LINE_AGENT.  Enter TRK if the agent two in an SPC is a trunk and datafill refinements CLLI and EXTRKNM.
	LINE_AGENT	see subfields	<i>Line agent</i> If the entry in subfield AGNTYPE is LINE, datafill this refinement. This field is similar to field LEN in other tables. Refer to the field LEN description as follows.  This field defines the physical location of the equipment that is connected to a specific telephone line.  Because field LEN is common to more than 60 tables, it is documented in a single section to avoid unnecessary duplication. Refer to section "Common entry field LEN" for a complete description of field LEN and associated subfields.  Field LEN consists of subfields SITE, FRAME, UNIT, DRAWER or LSG, SHELF, SLOT, and CIRCUIT.  Only LCMEs and IRLCMs can be datafilled.



**SPCCON** (end)

**Field descriptions (Sheet 3 of 3)**

Field	Subfield or refinement	Entry	Explanation and action
CONNECT	CLLI	alphanumeric (1 to 16 characters)	<i>Common language location identifier</i> If the entry in subfield AGNTYPE is TRK, datafill this refinement. Enter the code assigned in table CLLI to the trunk that is agent two in the SPC.
	EXTRKNM	0 to 9999	<i>External trunk number</i> If the entry in subfield AGNTYPE is TRK, datafill this refinement. Enter the external trunk number assigned to the trunk that is agent two in the SPC.
		Y or N	<i>Connect</i> Enter Y (yes) to establish immediate connection. Enter N (no) to have the connection taken down.

**Datafill example**

The following example shows sample datafill for table SPCCON.

In the example, the SPC uses a trunk with a CLLI of LON100 and a member number of 23, and a line with a line agent) of HOST 0 1 3 6. This connection is required immediately.

**MAP display example for table SPCCON**

SPCKEY	AGENT1	AGENT2	CONNECT
SEMIPERM1	TRK LON100 23	LINE HOST 00 1 03 06	Y

**Supplementary information**

None

---

**SPCTRKS**

---

**Table name**

Stored Program Control Trunks Table

**Functional description**

The SPC-CMS extensibility project provides for the integration of stored program control (SPC) switches, specifically SP-1/2W and #1ESS designs, into the Bell Canada Call Management Services (CMS) network.

In the digital switch environment, CLID data is transferred between switches using the integrated services digital network user part (ISUP) layer of the Common Channel Signaling No. 7 (CCS7) network. Since SPC switches support per trunk signaling only, the conventional signaling method for CLID messages is not available. To provide for CCS7 messaging between DMS and SPC switches, an adjunct processor, known as a central office data processor (CODP), is attached to each SPC switch.

One of the functions of the CODP is the maintenance of transaction capability application part (TCAP) links to DMS switches. In the SPC-CMS extensibility project, these TCAP links, rather than ISUP links, are used to transfer CLID messages. In the remainder of this section, an SPC switch is considered to include the CODP adjunct.

Since SPC switches do not support CMS features, the purpose of the SPC-CMS extensibility project is to transfer only the CLID data from an SPC switch to a DMS switch. Since CCS7 links provide a common path for signaling information, some method is required at the receiving end to route the information to the correct call process. The CLID message is attached to a call process when the SPC specifies the trunk index of the PTS trunk on which the call has been routed. Within the receiving DMS switch, the trunk index is mapped back to a trunk circuit name. The DMS then attaches the CLID message to an incoming call on the given trunk circuit.

The following figure shows the interconnection between a DMS switch and an SPC switch.

**SPCTRKS** (continued)**Description of fields in table SPCTRKS**

Table SPCTRKS contains entries that permit the mapping of an SPC trunk index, supplied in a TCAP CLID message, to a trunk circuit name. The trunk circuit name is composed of the trunk group CLI and the trunk member number and forms the key to table SPCTRKS. The trunk member must have been previously datafilled in table TRKMEM. Also, the trunk type must have been datafilled before attempting to add the SPCTRKS tuple. If the trunk name has not been datafilled in table TRKMEM or the trunk type is not supported for this feature, an error message explaining the error is displayed. See section "Restrictions and limitations" for the trunk types supported by this feature.

The SPC trunk index is a numeric value, in the range 0 to 8191, known to both the DMS switch and one of the SPC switches connected to the DMS switch. Within the DMS switch, an SPC trunk index is uniquely identified with a trunk circuit. Within an SPC switch, the SPC trunk index need not be unique. Since the DMS switch requires each of its SPC trunk indices to be unique and the SPC does not, the SPC trunk indexes should be assigned to DMS switches and transferred to SPCs. If SPC trunk indexes are assigned to SPC switches and then transferred to DMS switches, there is no guarantee of uniqueness at the DMS end. Note that the SPC trunk index is manually datafilled at both the DMS switch and the SPC switch.

Other than the SPC trunk index, only one other data item is stored in table SPCTRKS. This item is referred to as the administration number. The administration number is a numeric value in the range 0 to 31. This value is not used within the DMS switch for any purpose. The suggested use of the administration number is to identify the SPC switch from which the trunk circuit originates. No checking is performed on the value of the administration number other than to verify that it is within the specified range.

---

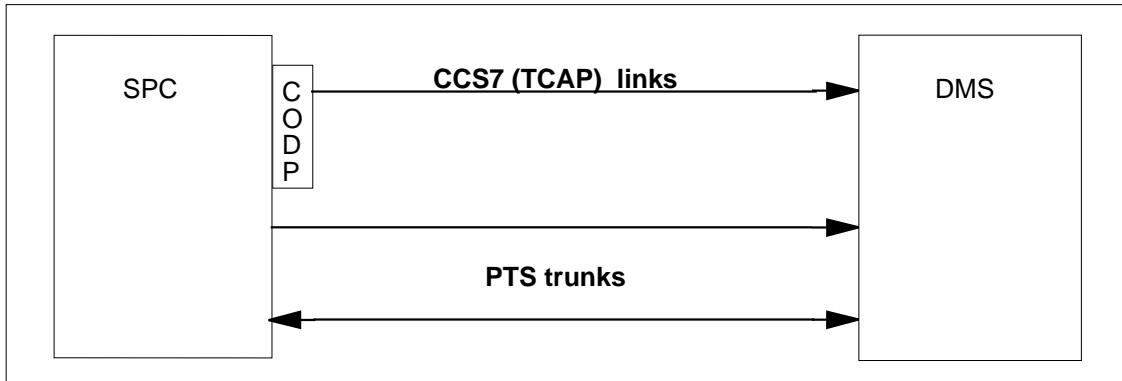
**SPCTRKS** (continued)

---

**Relationship of table SPCTRKS to other customer tables**

The key to table SPCTRKS is the same as the key to table TRKMEM. If the corresponding tuple in table TRKMEM is not datafilled, the tuple cannot be added to table SPCTRKS. Conversely, the entry in table SPCTRKS must be deleted before deleting the corresponding entry in table TRKMEM.

**Interactions**

Table SPCTRKS references entries in table TRKMEM. Before deleting an entry in table TRKMEM, the corresponding entry in table SPCTRKS, if any, must be deleted. Conversely, no entry may be made in table SPCTRKS before the corresponding entry has been made in table TRKMEM.

**Restrictions and limitations**

Checks are performed on the trunk circuit data to verify that the trunk direction and signaling type is supported by the SPC-CMS interface. Both dial pulse (DP) and multifrequency (MF) signaling types are supported. Only local incoming (TI) and local two-way (T2) trunk types are supported. Overlap outpulsing and cut-through dialing are not supported. Since some features, such as overlap outpulsing, are assigned on a group basis, this feature assumes that all trunks in a group terminate on the same switch.

When the first member of a trunk subgroup is datafilled in table SPCTRKS, call processing assumes that a CLID message is sent for all members of that subgroup. If some members are not datafilled in table SPCTRKS, call processing assumes that the CLID it was expecting never arrived. It is important that all members of the subgroup be datafilled in table SPCTRKS.

**Datafill sequence and implications**

Table TRKMEM must be datafilled before table SPCTRKS.

Trunks must be datafilled in table TRKMEM before they are added to this table. Trunks must be removed from this table before they are removed from table TRKMEM.

**Table size**

0 to 8191 tuples

This size of this table is dynamically allocated up to a maximum of 8191 tuples.

**SPCTRKS** (continued)**Datafill**

The following table lists datafill for table SPCTRKS.

**Field descriptions (Sheet 1 of 2)**

Field	Subfield or refinement	Entry	Explanation and action
TRKNAME		see subfields	<p><i>Trunk name</i></p> <p>This field is the key to this table and is the same as the key to table TRKMEM. This field is made up of subfields CLLI and MEMNAME, and maps to give the SPCTKIDX. Any TRKNAME value must have been previously datafilled in table TRKMEM. Checks are performed on the trunk circuit data to verify that the trunk group type and signaling type are supported by the SPC-CMS interface. Both DP and MF signaling types are supported. Only local incoming (T1) and local two-way (T2) trunk types are supported. Overlap outpulsing and cut-through dialing are not supported.</p>
I	CLL	alphanumeric (1 to 16 characters)	<p><i>Common language location identifier</i></p> <p>Enter the code, previously datafilled in table TRKMEM, that maps (together with MEMNAME) to the SPCTKIDX.</p>
	MEMNAME	numeric (0 to 9999)	<p><i>Trunk group member</i></p> <p>Enter the trunk group member number, previously datafilled in table TRKMEM, that maps (together with CLLI) to the SPCTKIDX.</p>

**SPCTRKS** (continued)**Field descriptions (Sheet 2 of 2)**

Field	Subfield or refinement	Entry	Explanation and action
SPCTKIDX		numeric (0 to 8191)	<i>Stored program control trunk index</i>  Enter a number, known to both the DMS switch and one of the SPC switches, that uniquely identifies a SPC trunk circuit. This value represents a trunk index sent from an SPC switch in a TCAP CLID message. The SPCTKIDX values datafilled in this table must also be datafilled in one of the SPC switches connected to the DMS switch. So that CLID messages are successfully attached to calls, the SPC switches connected to the DMS switch must be datafilled with the same SPCTKIDX values that are datafilled on the DMS switch.
ADMINNUM		numeric (0 to 31)	<i>Administration number</i>  This value is not used in the DMS switch for any purpose. The suggested use of the administration number is to identify the SPC switch from which the trunk circuit originates. This field is provided to assist the craftsperson in coordinating datafill between the DMS switch and the connected SPC switches.

**Datafill example**

The following example shows sample datafill for table SPCTRKS.

In this example, ranges of SPC trunk indexes have been reserved for combinations of trunk types and originating locations.

## SPCTRKS (end)

---

### MAP display example for table SPCTRKS

TRKNAME		SPCTKIDX	ADMINNUM
ICAMDCM	1	0	10
ICAMDCM	2	7	10
ICAMDCM	3	5	10
INMF1	1	240	2
INMF1	2	248	2
IDDP	82	1020	25
IDDP	87	1002	25
IDDP	89	953	25
IDDP	94	1177	25

---

**SPECCONN**

---

**Table name**

The P-side to P-side Special Connection Table

**Functional description**

Table SPECCONN is for the data entry of special connections that the switch requires. Table SPECCONN contains one tuple for each special connection. Each special connection contains correct endpoints. These endpoints connect with a permanent nailed up connection. The connection can involve the following:

- one or more extended multiprocessor system (XMS)-based peripheral module (XPM)
- one or more integrated services digital network (ISDN) line concentrating device (LCD)
- the Digital Multiplex System (DMS) network, that depends on the type and location of the endpoints

The ISDN is not the only user of This utility is not only for ISDN use.

**Peripheral module types**

Table SPECCONN supports the following peripheral module (PM) types:

- ADTC (Austrian digital trunk controller)
- ALGC (Austrian line group controller)
- ARCC (Austrian remote cluster controller)
- DTC (digital trunk controller [controls only digital trunks])
- DTCI (ISDN digital trunk controller)
- GPP (global peripheral platform)
- LGC (line group controller [controls lines only])
- LTC (line trunk controller [controls lines and digital trunks])
- PDTC (pulse code modulation 30 [PCM30] digital trunk controller)
- PLGC (PCM30 line group controller)
- RCO2 (remote cluster controller 2 offshore)
- RCC2 (remote cluster controller 2)
- SMA (subscriber carrier module-100 access)
- SMU (subscriber module urban [controls remote concentrator terminal (RCT) of the DMS-1U system])



## **SPECCONN** (continued)

---

- SRCC (Synchronous Optical Network [SONET] remote cluster controller)
- TMS (Traffic Operator Position System [TOPS] message switch)

### **Datafill sequence and meaning**

You must enter data in the following tables before you enter data in table SPECCONN:

- IACINV
- IACPSINV
- LNINV
- STINV
- XSGDEF

Enter data in the following tables before you enter special connections that relate to an RCC2 in to table SPECCONN. This sequence provides basic rate interface (BRI) ISDN services for RCC2:

- LTCINV
- LTCPSINV
- CARRMTC
- DCHINV
- RCCINV
- RCCPSINV
- LCMINV
- LNINV

For the SMU remote carrier urban (RCU) subsystem, you must enter data in the following tables before you enter data in table SPECCONN:

- LTCINV
- LTCPSINV
- RCUINV
- LNINV

For TMS endpoint connections, you must enter data in the following tables before you enter data in table SPECCONN:

- TDCDEF
- TPCINV

**SPECCONN** (continued)

- TMSPSDEV
- ISGDEF for TMS

**ATTENTION**

The ISDN line drawer for remotes ILDR is first available for remote switching center-SONET (RSC-S) and remote switching center (RSC) configurations in the NA007/XPM08 timeframe. The ILDR is first available for remote line concentrating module (RLCM), outside plant module (OPM), and outside plant access cabinet (OPAC) configurations in the NA008/XPM81 timeframe.

For the initial release of the ILDR product in NA007, each line drawer can have a maximum of two Bd-channels. These Bd-channels are only for one hundred percent low speed packet data. The delivery of feature AF6811, ILDR Overload Control, removes this engineering limit for 100 percent packet data use on the ISDN Delta channel in NA008.

You can create a new endpoint in table SPECCONN to support the Bd-channels in the ISDN line drawer for remotes (ILDR). To perform this action, you must enter data in the following tables before you enter data in table SPECCONN:

- LCMDRINV
- LNINV

**Table size**

0 to 2724 segments

Each SPECCONN tuple has two to seven segments. The endpoints involved determine the number of segments. To determine the potential number of tuples, divide the total number of segments by the accurate number of segments in use. For example,  $2724 \div 2 = 1362$  tuples.  $2724 \div 7 = 389.1428$  tuples.

The number of peripheral modules (PM) involved between the endpoints determines the number of segments used. When the number of PMs, the number of segments increases.

For CSP02 and later versions, table DATASIZE does not require tuple SPECCONN. For CSP02 and later versions, you do not require a restart to increase the table size. Before CSP02, you increased the size in table DATASIZE and performed a restart to extend the length of the table.

**SPECCONN** (continued)

---

**Datafill**

Datafill for table SPECCONN appears in the following table.

**Field descriptions (Sheet 1 of 3)**

<b>Field</b>	<b>Subfield or refinement</b>	<b>Entry</b>	<b>Explanation and action</b>
ENDPT1		see subfield	<i>Endpoint 1</i> This field is the identifier of the first endpoint of the connection. This field contains subfield SCSEL.

**SPECCONN** (continued)

## Field descriptions (Sheet 2 of 3)

Field	Subfield or refinement	Entry	Explanation and action
	SCSEL	D30, DCHCHNL, DS0T, DS1, ISLC, RCUL, ST, ILDCHNL, or XSGCHNL	<p><i>Endpoint selector</i> Enter the type of selector for endpoints. Endpoints RCUL and DS0T cannot connect to DS-1, ISLC, or DCHCHNL endpoints.</p> <p>Enter D30 for the PCM30 format. Enter data in refinements PMTYPE, DEQNO, DQCKTNO, and DEQCKTTS. A description of this procedure appears in the following table in Section "SCSEL = D30"..</p> <p>Enter DCHCHNL for the D-channel handler channel. Enter data in refinements ISGNO and CHNL. A description of this procedure appears in the third table in this document in Section "SCSEL = DCHCHNL".</p> <p>Enter DS0T for the DS0T selector. Enter data in refinements XPMTYPE, PMNO, PORT, CHNL, TCINFO, CGAMODE, TCSIG, and TCPCM. A description of this procedure appears in the table in Section "SCSEL = SSOT"..</p> <p>Enter DS1 for the DS1 channel. Enter data in refinement PMTYPCT. A description of this procedure appears in the table in Section "SCSEL = DS1".</p> <p>Enter ISLC for the ISDN line card. Enter data in refinements LEN and CHNL. A description of this procedure appears in the table in Section "SCSEL = ISLC".</p>

**SPECCONN** (continued)**Field descriptions (Sheet 3 of 3)**

<b>Field</b>	<b>Subfield or refinement</b>	<b>Entry</b>	<b>Explanation and action</b>
	SCSEL (continued)		<p>Enter RCUL for the remote carrier urban line card. Enter data in refinements LEN, TCINFO, ATTEN, and FXBCGA. A description of this procedure appears in the table in Section "SCSEL = RCUL".</p> <p>Enter ST for the signaling terminal. Enter data in refinement STNO. A description of this procedure appears in the table in Section "SCSEL = ST".</p> <p>Enter ILDCHNL for the ISDN Line Drawer. Enter data in refinements SITE, FRAME, UNIT, DRAWER_NO, and BD_CHNL. A description of this procedure appears in the table in Section "SCSEL = ILDCHNL".</p> <p>Enter XSGCHNL for the X.25/X.75 services user group channel. Enter data in refinements XSGNO and CHNL. A description of this procedure appears in the table in Section "SCSEL = XSGCHNL".</p>

**SPECCONN** (continued)**SCSEL = D30**

When the entry in subfield SCSEL is D30, enter data in refinements for subfield PMTYPE. The data entry sequence appears in the following table.

**Field descriptions for conditional datafill (Sheet 1 of 3)**

Field	Subfield or refinement	Entry	Explanation and action
	PMTYPE	ADTC, ALGC, ARCC, GPP, PDTC, PLGC, RCO2, or SMA	<p><i>Peripheral module type.</i> Enter the peripheral module (PM) type.</p> <p>Enter ADTC for an Austrian digital trunk controller. Enter data in refinements DEQNO, DEQCKTNO, and DEQCKTTS.</p> <p>Enter ALGC for an Austrian line group controller. Enter data in refinements DEQNO, DEQCKTNO, and DEQCKTTS.</p> <p>Enter ARCC for an Austrian remote cluster controller. Enter data in refinements DEQNO, DEQCKTNO, and DEQCKTTS.</p> <p>Enter GPP for a global peripheral platform. Enter data in refinements IPMNO, ICPMCKTNO, and ICPMCKTTS.</p> <p>Enter PDTC for a PCM30 digital trunk controller. Enter data in refinements DEQNO, DEQCKTNO, and DEQCKTTS.</p> <p>Enter PLGC for a PCM30 line group controller. Enter data in refinements DEQNO, DEQCKTNO, and DEQCKTTS.</p> <p>Enter RCO2 for an offshore remote cluster controller 2. Enter data in refinements RCO2NO, RCO2CKTNO, and RCO2CKTTS.</p> <p>Enter SMA for a subscriber carrier module-100S access. Enter data in refinements SMANO, SMACKTNO, and SMACKTTS.</p> <p>Entries out of the specified range for this field are incorrect.</p>
	DEQNO	0 to 511	<p><i>Equipment module number</i> When the entry in field PMTYPE is ADTC, ALGC, ARCC, PDTC, or PLGC, enter data in this refinement. Enter the external number of the PM.</p>

**SPECCONN** (continued)

## Field descriptions for conditional datafill (Sheet 2 of 3)

Field	Subfield or refinement	Entry	Explanation and action
	DEQCKTNO	0 to 19	<i>Equipment module circuit number</i> . When the entry in field PMTYPE is ADTC, ALGC, ARCC, PDTC, or PLGC, enter data in this refinement. Enter the peripheral (P)-side port number on the equipment.
	DEQCKTTS	1 to 31	<i>Equipment module time slot</i> . When the entry in field PMTYPE is ADTC, ALGC, ARCC, PDTC, or PLGC, enter data in this refinement. Enter the time slot (channel) on the D30.
	IPMNO	0 to 511	<i>International peripheral module number</i> . When the entry in field PMTYPE is GPP, enter this refinement. Enter the external number of the GPP.
	ICPMCKTNO	0 to 47	<i>International peripheral module circuit number</i> . When the entry in field PMTYPE is GPP, enter data in this refinement. Enter the peripheral (P)-side port number on the GPP.
	ICPMCKTTS	1 to 31	<i>International peripheral module time slot</i> . When the entry in field PMTYPE is GPP, enter data in this refinement. Enter the time slot (channel) on the D-30.
	RCO2NO	0 to 511	<i>Offshore remote cluster controller 2 number</i> . When the entry in field PMTYPE is RCO2, enter data in this refinement. Enter the external number of the RCO2.
	RCO2CKTNO	0 to 47	<i>Offshore remote cluster controller 2 circuit number</i> . When the entry in field PMTYPE is RCO2, enter data in this refinement. Enter the P-side port number on the RCO2.
	RCO2CKTTS	1 to 31	<i>Offshore remote cluster controller 2 time slot</i> . When the entry in field PMTYPE is RCO2, enter data in this refinement. Enter the time slot (channel) on the D-30.
	SMANO	0 to 511	<i>Subscriber carrier module-100S access number</i> . When the entry in field PMTYPE is SMA, enter data in this refinement. Enter the external number of the SMA.

**SPECCONN** (continued)**Field descriptions for conditional datafill (Sheet 3 of 3)**

Field	Subfield or refinement	Entry	Explanation and action
	SMACKTNO	0 to 19	<i>Subscriber carrier module-100S access circuit number.</i> When the entry in field PMTYPE is SMA, enter data in this refinement. Enter the P-side port number on the SMA.
	SMACKTTS	1 to 24	<i>Subscriber carrier module-100S access time slot.</i> When the entry in field PMTYPE is SMA, enter data in this refinement. Enter the time slot (channel) on the D30.

**SCSEL = DCHCHNL**

When the entry in subfield SCSEL is DCHCHNL, enter data in refinements ISGNO and CHNL. The data entry sequence appears in the following table.

**Field descriptions for conditional datafill**

Field	Subfield or refinement	Entry	Explanation and action
	ISGNO	0 to 255	<i>D-channel handler number.</i> Enter the D-channel handler identifier.
	CHNL	0 to 31	<i>Channel number.</i> Enter the channel on the D-channel handler.

**SCSEL = DS0T**

When the entry in subfield SCSEL is DS0T, enter data in refinements XPMTYPE, PMNO, PORT, CHNL, TCINFO, CGAMODE, TCSIG, and TCPCM. The data entry sequence appears in the following table.

**Field descriptions for conditional datafill (Sheet 1 of 3)**

Field	Subfield or refinement	Entry	Explanation and action
	XPMTYPE	alphanumeric	<i>XPM type.</i> Enter SMU for the subscriber carrier module-100 urban.
	PMNO	0 to 255	<i>Peripheral module number.</i> Enter the external number of the SMU.



**SPECCONN** (continued)

## Field descriptions for conditional datafill (Sheet 2 of 3)

Field	Subfield or refinement	Entry	Explanation and action
	PORT	0 to 47	<i>Port.</i> Enter the P-side port number on the SMU.
	CHNL	1 to 24	<i>Channel.</i> Enter the time slot (channel) on the DS-1.
	TCINFO	see subfields	<i>Trunk conditioning information.</i> This field contains subfields CGAMODE, TCSIG, and TCPCM.
	CGAMODE	DT, FT, OP, VN, or VT	<p><i>Carrier group alarm mode.</i> Enter the type of trunk conditioning applied for each channel.</p> <p>Enter DT for dataport transparent. The transmission of a multiplexer out-of-synchronization (MUX-OOS) pulse code modulation (PCM) pattern (00011010) occurs. The transmission of A- or B-bits does not occur. The refinements do not require datafill.</p> <p>Enter FT full transparent. The application of trunk conditioning does not occur. The transmission of the incoming PCM pattern occurs. The use of A- or B-bits does not occur. The refinements do not require datafill.</p> <p>Enter OP for optional. Operating company personnel supply a PCM pattern in hexadecimal. No A- or B-bits are used. Enter data in refinement TCPCM.</p> <p>Enter VN for voice nontransparent. The transmission of idle PCM (01111111) occurs. The operating company personnel specify the A- and B-bits transmitted. Operating company personnel specify these bits in subfield TCSIG.</p> <p>Enter VT for Voice Transparent. The transmission of idle PCM occurs. The transmission of A- or B-bits does not occur. The refinements do not require datafill.</p>

**SPECCONN** (continued)**Field descriptions for conditional datafill (Sheet 3 of 3)**

<b>Field</b>	<b>Subfield or refinement</b>	<b>Entry</b>	<b>Explanation and action</b>
	TCCPM	00 to FF	<i>Trunk conditioning pulse code modulation pattern.</i> When the entry in subfield CGAMODE is OP, enter data in this refinement. Enter a two-digit hexadecimal value in use for trunk conditioning.
	TCSIG	0000 to 1111 (binary)	<i>Trunk conditioning signaling bits.</i> When the entry in subfield CGAMODE is VN, enter data in this refinement. Enter the four signaling bits. The first two bits, A1 and B1, are the A- and B-bits that the system transmits for the first 2.5 s. The second two bits are A2 and B2. These bits are the A- and B-bits that the system transmits for the duration of the failure.

**SPECCONN** (continued)**SCSEL = DS1**

When the entry in subfield SCSEL is DS1, enter data in refinement PMTYPCT. The data entry sequence appears in the following table.

**Field descriptions for conditional datafill (Sheet 1 of 5)**

<b>Field</b>	<b>Subfield or refinement</b>	<b>Entry</b>	<b>Explanation and action</b>
	PMTYPCT	see subfield	<i>Peripheral module type.</i> This field contains subfield PMTYPE.
	PMTYPE	DTC, DTCI, LGC, LTC, RCC2, SMA, SMU, SRCC, or TMS	<p><i>Peripheral module type.</i> Enter the type of peripheral module (PM). Refinements for each PM follow in alphabetical order:</p> <p>Enter DTC for a digital trunk controller. Enter data in refinements DTCNO, DTCCCKTNO, and DTCCCKTTS.</p> <p>Enter DTCI for an ISDN DTC. Enter data in refinements DTCINO, DTCICKTNO, and DTCICKTTS.</p> <p>Enter LGC for a line group controller. Enter data in refinements LGCNO, LGCCCKTNO, and LGCCCKTTS.</p> <p>Enter LTC for a line trunk controller. Enter data in refinements LTCNO, LTCCCKTNO, and LTCCCKTTS.</p> <p>Enter RCC2 for an RCC 2. Enter data in refinements RCC2NO, RCC2CKTNO, and RCC2CKTTS.</p>

**SPECCONN** (continued)

## Field descriptions for conditional datafill (Sheet 2 of 5)

Field	Subfield or refinement	Entry	Explanation and action
	PMTYPE (continued)		<p>Enter SMA for a subscriber carrier module-100S access. Enter data in refinements SMANO, SMACKTNO, and SMACKTTS.</p> <p>Enter SMU for a subscriber carrier module-100S urban. Enter data in refinements SMUNO, SMUCTNO, and SMUCTTTS.</p> <p>Enter SRCC for a SONET remote cluster controller. Enter data in refinements SRCCNO, SRCCCKTNO, and SRCCCKTTS.</p> <p>Enter TMS for a Traffic Operator Position System (TOPS) message switch. Enter data in refinements TMSNO, TMSCKTNO, and TMSCKTTS.</p> <p>Entries out of the specified range for this field are incorrect.</p>
	DTCNO	0 to 511	<i>Digital trunk controller number.</i> When the entry in field PMTYPE is DTC. Enter data in this refinement. Enter the external number of the DTC.
	DTCCKTNO	0 to 19	<i>Digital trunk controller circuit number.</i> When the entry in field PMTYPE is DTC, enter data in this refinement. Enter the P-side port number on the DTC.
	DTCCKTTS	1 to 24	<i>Time slot.</i> When the entry in field PMTYPE is DTC, enter data in this refinement. Enter the time slot (channel) on the DS-1.
	DTCINO	0 to 511	<i>Digital trunk controller number.</i> When the entry in field PMTYPE is DTCl, enter data in this refinement. Enter the external number of the DTCl.
	DTCICKTNO	0 to 19	<i>Digital trunk controller circuit number.</i> When the entry in field PMTYPE is DTCl, enter data in this refinement. Enter the P-side port number on the DTCl.

**SPECCONN** (continued)**Field descriptions for conditional datafill (Sheet 3 of 5)**

<b>Field</b>	<b>Subfield or refinement</b>	<b>Entry</b>	<b>Explanation and action</b>
	DTCICKTTS	1 to 24	<i>Digital trunk controller time slot.</i> When the entry in field PMTYPE is DTCl, enter data in this refinement. Enter the time slot (channel) on the DS-1.
	LGCNO	0 to 511	<i>Line group controller number.</i> When the entry in field PMTYPE is LGC, enter data in this refinement. Enter the external number of the LGC.
	LGCKTNO	0 to 19	<i>Line group controller circuit number.</i> When the entry in field PMTYPE is LGC, enter data in this refinement. Enter the P-side port number on the LGC.
	LGCKTTS	1 to 24	<i>Time slot.</i> When the entry in field PMTYPE is LGC, enter data in this refinement. Enter the time slot (channel) on the DS-1.
	LTCNO	0 to 511	<i>Line trunk controller module number.</i> When the entry in field PMTYPE is LTC, enter data in this refinement. Enter the external number of the LTC.
	LTCKTNO	0 to 19	<i>Line trunk controller circuit number.</i> When the entry in field PMTYPE is LTC, enter data in this refinement. Enter the P-side port number on the LTC.
	LTCKTTS	1 to 24	<i>Line trunk controller time slot.</i> When the entry in field PMTYPE is LTC, enter data in this refinement. Enter the time slot (channel) on the DS-1.
	RCC2NO	0 to 511	<i>Remote cluster controller 2 number.</i> When the entry in field PMTYPE is RCC2, enter data in this refinement. Enter the external number of the RCC2.
	RCC2CKTNO	0 to 47	<i>Remote cluster controller 2 circuit number.</i> When the entry in field PMTYPE is RCC2, enter data in this refinement. Enter the P-side port number on the RCC2.

**SPECCONN** (continued)**Field descriptions for conditional datafill (Sheet 4 of 5)**

<b>Field</b>	<b>Subfield or refinement</b>	<b>Entry</b>	<b>Explanation and action</b>
	RCC2CKTTS	1 to 24	<i>Remote cluster controller 2 time slot. When the entry in field PMTYPE is RCC2, enter data in this refinement. Enter the time slot (channel) on the DS-1.</i>
	SMANO	0 to 511	<i>Subscriber carrier module-100S access number. When the entry in field PMTYPE is SMA, enter data in this refinement. Enter the external number of the SMA.</i>
	SMACKTNO	0 to 19	<i>Subscriber carrier module-100S access circuit number. When the entry in field PMTYPE is SMA, enter data in this refinement. Enter the P-side port number on the SMA.</i>
	SMACKTTS	1 to 24	<i>Subscriber carrier module-100S access time slot. When the entry in field PMTYPE is SMA, enter data in this refinement. Enter the time slot (channel) on the DS-1.</i>
	SMUNO	0 to 511	<i>Subscriber carrier module-100S urban number. When the entry in field PMTYPE is SMU, enter data in this refinement. Enter the external number of the SMU.</i>
	SMUCTNO	0 to 19	<i>Subscriber carrier module-100S urban circuit number. When the entry in field PMTYPE is SMU, enter data in this refinement. Enter the P-side port number on the SMU.</i>
	SMUCTTTS	1 to 24	<i>Subscriber carrier module-100S access time slot. When the entry in field PMTYPE is SMU, enter data in this refinement. Enter the time slot (channel) on the DS-1.</i>
	SRCCNO	0 to 511	<i>SONET remote cluster controller number. When the entry in field PMTYPE is SRCC, enter data in this refinement. Enter the external number of the SRCC.</i>
	SRCCCKTNO	0 to 47	<i>SONET remote cluster controller circuit number. When the entry in field PMTYPE is SRCC, enter data in this refinement. Enter the P-side port number on the SRCC.</i>

**SPECCONN** (continued)**Field descriptions for conditional datafill (Sheet 5 of 5)**

<b>Field</b>	<b>Subfield or refinement</b>	<b>Entry</b>	<b>Explanation and action</b>
	SRCCCKTTS	1 to 24	<i>SONET remote cluster controller time slot.</i> When the entry in field PMTYPE is SRCC, enter data in this refinement. Enter the time slot (channel) on the DS-1.
	TMSNO	0 to 255	<i>Traffic Operator Position System message switch number.</i> When the entry in field PMTYPE is TMS, enter data in this refinement. Enter the external number of the TMS.
	TMSCKTNO	0 to 19	<i>TOPS message switch circuit number.</i> When the entry in field PMTYPE is TMS, enter data in this refinement. Enter the P-side port number on the TMS.
	TMSCKTTS	1 to 31	<i>Traffic Operator Position System message switch time slot.</i> When the entry in field PMTYPE is TMS, enter data in this refinement. Enter the time slot (channel). Enter 1 to 24 for DS-1. Enter 1 to 15 and 17 to 31 for D30.

**SPECCONN** (continued)**SCSEL = ISLC**

When the entry in subfield SCSEL is ISLC, enter data in refinements LEN and CHNL. The data entry sequence appears in the following table.

**Field descriptions for conditional datafill**

Field	Subfield or refinement	Entry	Explanation and action
	LEN	see subfields	<p><i>Line equipment number.</i> This field defines the location of the equipment that connects to a specified telephone line.</p> <p>The field LEN is common to more than 60 tables. The documentation of field LEN appears in a single section to avoid a copy. See section "Common entry field LEN" for a complete description of field LEN and associated subfields.</p> <p>For ISDN lines, field LEN has subfield LTID. For non-ISDN lines, field LEN contains subfields SITE, FRAME, UNIT, DRAWER or LSG, SHELF, SLOT, and CIRCUIT.</p>
	CHNL	B1, B2, or D	<p><i>Channel.</i> Enter the ISLC channel.</p> <p>Entries out of the specified range for this field are incorrect.</p>



**SPECCONN** (continued)**SCSEL = RCUL**

When the entry in subfield SCSEL is RCUL, enter data in refinements LEN, TCINFO, ATTEN, and FXBCGA. The data entry sequence appears in the following table:

**Field descriptions for conditional datafill (Sheet 1 of 3)**

<b>Field</b>	<b>Subfield or refinement</b>	<b>Entry</b>	<b>Explanation and action</b>
	LEN	see subfields	<p><i>Line equipment number.</i> This field defines the location of the equipment that connects to a specified telephone line.</p> <p>The field LEN is common to more than 60 tables. The documentation of field LEN appears in a single section to avoid duplication. See section "Common entry field LEN" for a complete description of field LEN and associated subfields.</p> <p>For ISDN lines, field LEN has subfield LTID. For non-ISDN lines, field LEN has subfields SITE, FRAME, UNIT, DRAWER or LSG, SHELF, SLOT, and CIRCUIT.</p>
	TCINFO	see subfield	<p><i>Trunk conditioning information.</i> This field has subfield CGAMODE.</p>

**SPECCONN** (continued)**Field descriptions for conditional datafill (Sheet 2 of 3)**

Field	Subfield or refinement	Entry	Explanation and action
	CGAMODE	DT, FT, OP, VN, or VT	<p><i>Carrier group alarm mode.</i> Enter the type of trunk conditioning applied to each channel.</p> <p>Enter DT for dataport transparent. The transmission of a multiplexer out-of-synchronization (MUX-OOS) pulse code modulation (PCM) pattern (00011010) occurs. The transmission of A- or B-bits does not occur. The refinements do not require datafill.</p> <p>Enter FT for full transparent. The application of trunk conditioning does not occur. The transmission of incoming PCM pattern occurs. The use of A- or B-bits does not occur. The refinements do not require datafill.</p> <p>Enter OP for optional. Operating company personnel supply a PCM pattern in hexadecimal. The use of A- or B-bits does not occur. Enter data in refinement TCPCM.</p> <p>Enter VN for voice nontransparent. The transmission of idle PCM (01111111) occurs. Operating company personnel specify the A- and B-bits transmitted in refinement TCSIG.</p> <p>Enter VT for voice transparent. The transmission of idle PCM occurs. The transmission of A- or B-bits does not occur. The refinements do not require datafill.</p>
	TCPCM	00 to FF	<p><i>Trunk conditioning pulse code modulation pattern.</i> When the entry in subfield CGAMODE is OP, enter data in this refinement. Enter a two-digit hexadecimal value in use for trunk conditioning.</p>

**SPECCONN** (continued)**Field descriptions for conditional datafill (Sheet 3 of 3)**

Field	Subfield or refinement	Entry	Explanation and action
	TCSIG	0000 to 1111 (binary)	<i>Trunk conditioning signaling bits.</i> When the entry in subfield CGAMODE is VN, enter data in this refinement. Enter four signaling bits. The first two bits, A1 and B1, are the A- and B-bits that the system transmits for the first 2.5 s. The second two bits are A2 and B2. These bits are the A- and B-bits that the system transmits for the duration of the failure.
	ATTEN	0 to 7	<i>Attenuation.</i> Enter the amount of receive loss in decibels that the foreign exchange inserts with battery reversal (FXB) card. You can enter any value for special services modules (SSM) channel units. The system sets the field to 0.
	FXBCGA	ON or OFF	<i>Foreign exchange with battery carrier group alarm.</i> Enter ON when the remote carrier urban (RCU) to subscriber side supervisory signaling is on hook. Enter OFF. You can enter any value for SSM channel units. The system sets the field to ON.

**SCSEL = ST**

When the entry in subfield SCSEL is ST, enter data in refinement STNO. The data entry sequence appears in the following table:

**Field descriptions for conditional datafill**

Field	Subfield or refinement	Entry	Explanation and action
	STNO	0 to 1023	<i>Signaling terminal number.</i> Enter the signaling terminal number from table STINV.

**SPECCONN** (continued)**SCSEL = ILDCHNL**

When the entry in subfield SCSEL is ILDCHNL, enter data in refinements SITE, FRAME, UNIT, DRAWER\_NO, and BD\_CHNL. The data entry sequence appears in the following table.

**Field descriptions for conditional datafill**

Field	Subfield or refinement	Entry	Explanation and action
	SITE	4 chars	<i>The site of the LCM.</i> Enter the site of the LCM.
	FRAME	0 to 511	<i>The site of the LCM frame.</i> Enter the frame of the LCM.
	UNIT	0, 1	<i>The unit of the LCM.</i> Enter the unit of the LCM.
	DRAWER_NO	2 to 19	<i>The ILDR drawer number.</i> Enter the ILDR drawer number. You must enter an even drawer number.
	BD_CHNL	BD1, BD2	<i>The Bd channel.</i> Enter the requested Bd channel.

**SCSEL = XSGCHNL**

When the entry in subfield SCSEL is XSGCHNL, enter data in refinements XSGNO and CHNL. The data entry sequence appears in the following table.

**Field descriptions for conditional datafill**

Field	Subfield or refinement	Entry	Explanation and action
	XSGNO	0 to 749	<i>X.25/X.75 services user group.</i> Enter the X.25/X.75 services user group (XSG) number. The XSG number must correspond to an XSG in table XSGDEF.
	CHNL	1 to 31 or \$	<i>Channel.</i> Enter a channel number to identify one of 32 available channels in the XSG. Enter \$ to allow table SPECCONN to select a channel from the pool of free channels in the XSG.

**SPECCONN** (continued)

---

**ENDPOINT2**

Datafill for the second endpoint is identical to the datafill for the first endpoint. The datafill appears in the following table.

**Field descriptions for conditional datafill**

<b>Field</b>	<b>Subfield or refinement</b>	<b>Entry</b>	<b>Explanation and action</b>
ENDPT2		see subfield	<p><i>Endpoint2</i>. This field is the identifier of the second endpoint of the connection. This field contains subfield SCSEL.</p> <p>Repeat the data entry for subfield SCSEL under field ENDPT1. A description of this procedure appears in the first table in this document.</p> <p>When data entry is complete for endpoint 2, go to field CONTYPE in the next table in Section "ENDPT1 and ENDPT2"..</p>

**SPECCONN** (continued)**ENDPT1 and ENDPT2**

For the two endpoints, enter fields data in CONTYPE and STATUS. The data entry sequence appears in the following table:

**Field descriptions for conditional datafill**

Field	Subfield or refinement	Entry	Explanation and action
CONTYPE		CAB, CON, or PENDING	<p><i>Connection type.</i> Enter the connection type. Enter CAB for A-bit and B-bit signaling connected. Enter CON for connected. Enter PENDING for pending.</p> <p>Entries out of the specified range for this field is not correct.</p>
STATUS		ACTIVE INACTIVE MTC NOINTEG or PMBUSY	<p><i>Connection status.</i> Enter the status of the connection.</p> <p>Enter ACTIVE to indicate the physical establishment of the connection. Enter ACTIVE to indicate that the system finds integrity and performs continuous integrity checks.</p> <p>You cannot enter the other four status values. These values indicate the actual status of the connection, as follows:</p> <ul style="list-style-type: none"> <li>• INACTIVE indicates that the connection is not set up</li> <li>• MTC indicates that the connection is broken and that maintenance uses the connection</li> <li>• NOINTEG indicates that the connection physically, and the system cannot find integrity or loses integrity. This value indicates that the two XPMs are in service.</li> <li>• PMBUSY indicates that the connection is peripheral busy</li> </ul>

**Datafill example**

Sample datafill for table SPECCONN appears in the following example.

A pair of endpoints for a special service hairpin connection appears in the example. The first endpoint is an RCU line that has a LEN of RCU0 01 2 2 0.

**SPECCONN** (continued)

The prompt for the first endpoint is SCSEL. The prompt for the LEN of RCU0 01 2 2 0 is LEN. Voice nontransparent trunk conditioning occurs when one of the endpoints of this special-service hairpin connection goes out of service. The pattern sent is 10 for the duration of the failure. The attenuation that the card inserts is 0. The card supplies on-hook supervisory signaling toward the subscriber side when a special service connection failure occurs.

The second endpoint is a channel on a DS-1 link. The associated PM is SMU. The prompt for the second endpoint is SCSEL. The SMU connects to the link with port 2. Voice nontransparent trunk conditioning occurs when an endpoint goes out of service. In this condition, the A-bit and B-bit pattern is 00 for the first 2.5 s and 10 for the duration of the failure. The special service hairpin connection occurs with A- and B-bits. Field STATUS indicates that the connection is active.

**MAP example for table SPECCONN**

ENDPT1		ENDPT2	CONTYPE	STATUS
RCUL	RCU0 01 2 00 00 VN 1010 0	ON		
	DS0T SMU2 3 2 17 VN 0010	CAB		ACTIVE

**Table history****NA008**

Removed paragraph about BITS from table 5 subfield RCC2CKTNO. Table SPECCONN has been updated for the NA0011 release of this document. This update was made in response to a Problem Resolution System (PRS) request for the NA008 timeframe.

**NA007**

Entry ILDCHNL was added to subfield SCSEL. Table 9 was added in NA007. Table 9 contains the datafill for entry ILDCHNL.

**NA004**

The following changes were made to table LTCINV:

- A sentence was added to the description for field PMTYPE, subfield DEQCKTNO. This sentence states that table SPECCONN interacts with table SYLNKINV. This sentence verifies that P-side RCC2 DS-1 links 0

**SPECCONN** (continued)

or 8 are not defined as BITS synchronized links before the definition of the links as special connections

- References was removed to IAC, RCCI, and PRCC PM types that the system does not support now

**CSP02**

A sentence was added that a restart is not a requirement to increase table size. An entry for table SPECCONN is not a requirement in table DATASIZE.

**BCS36**

Entry ARCC was added to field PMTYPE for selector D30 in BCS36.

**Additional information**

This section provides information on possible error messages for TMS and ISDN during the data entry of table SPECCONN.

**Error messages for TMS endpoint connections**

The system can generate the following error messages when some of the previous conditions occur:

VOICE CIRCUITS MAY NOT BE CONNECTED TO DATA CIRCUITS

When an attempt occurs to use TMS endpoints and the TMS package is not available, the following message appears:

TMS IS NOT INCLUDED IN THE LOAD.

When an attempt occurs to use a DS-0 channel that is not entered in table TPCINV or TMSPSDEV, the following message appears:

TMS DS-1 CHANNELS USED IN SPECCONN MUST BE DATAFILLED IN TPCINV OR TMSPSDEV.

When an attempt occurs to specify a D-channel handler (DCH) channel that is nailed up, the following message appears:

TDC CHANNEL IS THE END POINT OF AN EXISTING SPECIAL CONNECTION

When an attempt occurs to delete a connection that is not present, the following message appears:

TDC IS NOT PART OF A SPECIAL CONNECTION

An attempt can occur to nail up a connection that uses a device that is different from the device that table TDCDEF specifies. This specification is for the



## SPECCONN (continued)

---

given port and channel. When this attempt occurs, the following message appears:

```
CANNOT NAIL UP CONNECTIONS BETWEEN ENDPT1 AND ENDPT2.    DEVICE
IN TABLE TDCDEF IS <device>.                               DEVICE IN
<TPCINV OR TMSPSDEV> IS <device>.
```

The addition of other error messages make sure that the two endpoints of a special connection have compatible functions. When the endpoint functions are not compatible, the following message appears:

```
THE ENDPOINTS HAVE INCOMPATIBLE FCNS.
```

One endpoint can be tandem and the other endpoint does not have the opposite signal mode. For example, station or office. When this event occurs, the following message appears:

```
TANDEM SIGMODE DOES NOT MATCH OTHER ENDPOINTS FCN OR BOTH
ENDPOINTS HAVE THE SAME TYPE TANDEM SIGMODE.
```

### Error messages for ISDN

The RCCI appears in the range of possible values in table SPECCONN. Table control software rejects data entry attempts that reference RCCI. The purpose of this condition is to enter RCCI when data entry of special connection endpoints in table SPECCONN occurs.

The system can generate the following error messages when some of the previous conditions occur:

```
CANNOT SEIZE LINE, LEN
DS-1 MUST BE PROPERLY CONFIGURED IN TABLE IACPSINV
DS-1 MUST BE PROPERLY CONFIGURED
DS-1 TERMINATES ON A REMOTE PERIPHERAL
DS-0 NOT ON AN EQUIPPED DS-1
ENDPOINTS MUST BE CONFIGURED ON THE SAME IAC
ENDPOINT MUST NOT BE A PART OF AN EXISTING SPECIAL CONNECTION
ENDPOINT MUST BE ON A RCU
INVALID CONNECTION TYPE
INVALID XPM TYPE
INVALID LEN
```

**SPECCONN** (continued)

LIKE FXB LINES MAY NOT BE CONNECTED TO EACH OTHER  
 LINE CANNOT HAVE A DN ASSIGNED  
 LINE ALREADY USED IN A SPECIAL CONNECTION  
 LINE MUST BE A SPECIAL SERVICES CIRCUIT  
 LINE MUST BE DATAFILLED IN TABLE LNINV  
 LEN MUST BE DATAFILLED IN TABLE LNINV  
 LINE MUST BE AN ISDN LINE  
 PORT AND CHANNEL ALREADY USED IN SPECIAL CONNECTION  
 RETURN TO SERVICE FAILED, LEN  
 SOFTWARE ERROR, CONSULT LOGS  
 SSM DPX CIRCUITS MAY ONLY BE CONNECTED TO DS0T ENDPOINTS  
 ST MUST BE PROPERLY CONFIGURED IN TABLE IACPSINV  
 ST MUST BE DATAFILLED IN TABLE STINV  
 THE ENDPOINT TYPES (SCSEL) ARE INCOMPATIBLE  
 THE IAC MUST BE DATAFILLED IN TABLE IACINV  
 THE SAME LEN CANNOT BE USED FOR BOTH ENDPOINTS  
 THE SAME PORT AND CHANNEL CANNOT BE USED FOR BOTH ENDPOINTS

When an attempt occurs to specify a DCH channel that is not a time division controller (TDC)-type channel in table ISGDEF occurs, the following message appears:

DCH <dchno> CHANNEL <chnl> IS NOT A TDC CHANNEL IS ISGDEF.

When an attempt occurs to delete a connection on a DCH channel that is not manual busy or offline, the following message appears:

CHANNEL MUST BE SET MANUAL BUSY OR OFFLINE

You cannot use command CHANGE to perform the following:

- change an endpoint
  - To change an endpoint requires the deletion of the associated tuple followed by the addition of the tuple with the required data.
- change field STATUS
- change the connection type when field STATUS = MTC

## **SPECCONN** (end)

---

You cannot use command DELETE when field STATUS = MTC.

NO CHANGE TO SPECCONN TUPLE IS ALLOWED DURING RECONFIGURATION OF LCME/LCMI #

You cannot add, change or delete a tuple that involves a B-channel. This B-channel can be of an enhanced line concentrating module (LCME)/ISDN line concentrating module (LCMI) under reconfiguration. Perform an attempt after the reconfiguration is complete.

The reconfiguration of links with ISDN special connections can occur while the XPM remains in service. The XPMs that this reconfiguration supports are the LTC, LGC, DTC, DTCI, ISDN LTC, and ISDN LGC.

An assignment of a B2-channel to the last card in an ISDN U-line card (ISLC) can occur. When this event occurs, the B2-channel is an ISDN line. The following error message appears:

ONLY THE B1-CHANNEL CAN BE ASSIGNED ON THE LAST CARD IN THE LINE CARD CARRIER.

When you enter a DS-1 selector on an SMU without the ISP option provisioned, the following error message appears:

ONLY ISDN CAPABLE SMUS SUPPORT DS-1 ENDPOINTS

**SPID****Table name**

Service Provider Identifier

**Functional description**

Table SPID defines the service provider IDs. There are two types of SPIDs:

- AO SPID - The account owner (AO) SPID is the company that provides the calling party's service.
- BSP SPID - The billing service provider (BSP) SPID is the company that provides billing services for the AO service provider.

**Datafill sequence and implications**

The following tables are datafilled after table SPID.

- DNSCRN
- SPIDDB
- TOPSPARM, parameter DEFAULT\_SPID

There is no requirement to datafill other tables prior to table SPID.

**Table size**

0 to 32765 tuples

**Datafill**

The following table lists datafill for table SPID.

**Field descriptions**

Field	Subfield or refinement	Entry	Explanation and action
SPID		exactly 4 alphanumeric characters	<p>Service provider identifier. Enter 4 alphanumeric characters. This value is used in tables SPIDDB, DNSCRN, and TOPSPARM (parameter DEFAULT_SPID).</p> <p>For an AO or BSP SPID returned in an OLNS query to be considered valid, the AO or BSP SPID must be datafilled in table SPID.</p> <p>Letters must be upper case. Also, the MAP display indicates up to 8 characters; however, exactly 4 characters must be entered.</p>

## SPID (continued)

---

### Datafill example

The following example shows sample datafill for table SPID.

#### MAP display example for table SPID

SPID ----- 1234 ABCD
-------------------------------

### Error messages

The following error messages apply to table SPID..

#### Error messages for table (Sheet 1 of 2)

Error message	Explanation and action
SPIDs must be exactly 4 alphanumeric characters	This message appears if an attempt is made to enter an SPID that is not four characters in length.
Only 0..9 and A..Z are supported	This message appears if an attempt is made to add an SPID with an invalid character.
SPID datafilled in table DNSCRN	This message appears if an attempt is made to delete an SPID that is being used by a tuple in table DNSCRN. In order to delete the SPID, all references to it must first be removed from table DNSCRN.
SPID datafilled in table TOPSTOPT	This message appears if an attempt is made to delete an SPID that is referenced by a tuple in table TOPSTOPT. In order to delete the SPID, all references to it must first be removed from table TOPSTOPT.

**Error messages for table (Sheet 2 of 2)**

Error message	Explanation and action
SPID datafilled in table SPIDDB	This message appears if an attempt is made to delete an SPID that is referenced by a tuple in table SPIDDB. In order to delete the SPID, all references to it must first be removed from table SPIDDB.
SPID datafilled in table TOPSPARM as DEFAULT_SPID	This message appears if an attempt is made to delete the SPID specified as the DEFAULT_SPID in table TOPSPARM. In order to delete the SPID, the DEFAULT_SPID must be changed to some other value in table TOPSPARM.

## Table history

### TOPS07

Table SPID was introduced by feature AF6711 in functionality Branding via SPID, ENSV0017.

## SPIDDB

### Table name

Service Provider Identifier Database

### Functional description

Table SPIDDB contains TOPS call processing data for SPIDs.

The originator's account owner service provider ID (AO SPID) is sent to TOPS MP and OPP compatible positions. Field SCRNDISP enables display of this information. However, the SPID display occupies the same area as the trunk group display. The switch decides which one to display according to the following table:

#### SPID/trunk group display hierarchy

Carrier status	Trunk group display	SPID display	Display used
Carrier call	yes	yes	Trunk group display
	yes	no	Trunk group display
	no	yes	neither
	no	no	neither
Non-carrier call	yes	yes	SPID display
	yes	no	Trunk group display
	no	yes	SPID display
	no	no	neither

The table above indicates that for carrier calls, the trunk group display is used. However, for non-carrier calls, the SPID display overrides the trunk group display when both are present.

Basic Purpose (BP) (that is, MPX) and Single Purpose (SP) (that is, TOPS IV) positions are not sent SPID information nor the associated screen display.

**SPIDDB** (continued)

For OPP-compatible positions, table TOPSPARM parameter OPP\_ALWAYS\_SEND\_SPID\_INFO affects the above hierarchy as shown in the following tables:

**SPID/Trunk Group Display Hierarchy with OPP\_ALWAYS\_SEND\_SPID\_INFO = N**

Carrier call	yes	yes	Trunk group display
	yes	no	Trunk group display
	no	yes	neither
	no	no	neither
Non-carrier call	yes	yes	SPID display
	yes	no	Trunk group display
	no	yes	SPID display
	no	no	neither

**SPID/Trunk Group Display Hierarchy with OPP\_ALWAYS\_SEND\_SPID\_INFO = Y**

Carrier or non-carrier call	yes	yes	SPID display and trunk group display
	yes	no	Trunk group display
	no	yes	SPID display
	no	no	neither

**Datafill sequence and implications**

The following tables must be datafilled before table SPIDDB.

- SPID
- BAGNAME
- ANNS
- BNSAGRMT
- CCVAGRMT



**SPIDDB** (continued)

**Table size**

0 to 32765 tuples

**Datafill**

The following table lists datafill for table SPIDDB.

**Field descriptions (Sheet 1 of 7)**

Field	Subfield or refinement	Entry	Explanation and action
SPID		value from table SPID	Service provider identifier. Enter an identifier defined in table SPID.
SCRNDISP		see subfield	Screen display. This field consists of subfield SPIDDISP.
	SPIDDISP	N or Y	Screen display. This field enables or disables operator display of the originator's AO SPID. Enter Y to enable or N to disable the display. If Y is entered, datafill refinement DISPLAY.  This display is applicable to TOPS MP and OPP compatible positions.
	DISPLAY	up to 8 characters	Display. Datafill this field if field SCRNDISP is set to Y. This display is sent to TOPS MP and OPP compatible positions.
OPERSYS		set of {OPERATOR, MCCS, ACTS, AABS, ADAS}, ALL, or NONE	Operator system. This field determines which operator systems require calling party branding prior to the call being connected to the system as follows: <ul style="list-style-type: none"> <li>• OPERATOR - Live TOPS operator</li> <li>• MCCS - Mechanized calling card service</li> <li>• ACTS - Automated coin toll service</li> <li>• AABS - Automated alternate billing service</li> <li>• ADAS - Automated directory assistance service</li> <li>• ALL - All of the above systems (OPERATOR, MCCS, ACTS, AABS, and ADAS)</li> <li>• NONE - No services</li> </ul>

**SPIDDB** (continued)**Field descriptions (Sheet 2 of 7)**

<b>Field</b>	<b>Subfield or refinement</b>	<b>Entry</b>	<b>Explanation and action</b>
TAANN		see subfield	Toll and assist announcement. This field consists of subfield BRAND_TA.
	BRAND_TA	Y or N	Branding toll and assist announcement. This field specifies whether TA calls should be branded for the SPID. Enter Y to brand or N not to brand. If Y is entered, datafill refinement TACLLI.
	TACLLI	name from table ANNS	Toll and assist CLLI name. If field TAANN = Y, datafill this field with an announcement CLLI for TA calls.
DAANN		see subfield	Directory assistance announcement. This field consists of subfield BRAND_DA.
	BRAND_DA	Y or N	Branding directory assistance announcement. This field specifies whether DA calls should be branded for the SPID. Enter Y to brand or N not to brand. If Y is entered, datafill refinement DACLLI.
	DACLLI	name from table ANNS	Directory assistance CLLI name. If field DAANN = Y, datafill this field with an announcement CLLI for DA calls.
ACTSANN		see subfield	Automated coin toll service announcement. This field consists of subfield ACTSBRND and refinements.
	ACTSBRND	Y or N	Automated coin toll service branding. This field enables ACTS back-end branding using this SPID. Enter Y to enable and datafill refinements CORRCTDP and OVERDEP. Enter N to disable and no refinements require datafill. The default. over a One Night Process (ONP) is N.
	CORRCTDP	see subfields	Correct deposit. This field consists of subfields CLLI and ANNNUM.

**SPIDDB** (continued)**Field descriptions (Sheet 3 of 7)**

<b>Field</b>	<b>Subfield or refinement</b>	<b>Entry</b>	<b>Explanation and action</b>
	CLLI	name from table ANNS	Common language location identifier. Enter the name for the correct deposit announcement. The name must be datafilled in table ANNS. The CLLI and ANNUM pair must be datafilled in table DRMUSERS.
	ANNNUM	number from table DRMUSERS	Announcement number. Enter the index into table DRMUSERS for the correct deposit announcement. This index must be datafilled in table DRMUSERS. The CLLI and ANNUM pair must be datafilled in table DRMUSERS.
	OVERDEP	see subfields	Over deposit. This field consists of subfields CLLI and ANNNUM.
	CLLI	name from table ANNS	Common language location identifier. Enter the name for the over deposit announcement. The name must be datafilled in table ANNS. The CLLI and ANNUM pair must be datafilled in table DRMUSERS.
	ANNNUM	number from table DRMUSERS	Announcement number. Enter the index into table DRMUSERS for the over deposit announcement. This index must be datafilled in table DRMUSERS. The CLLI and ANNUM pair must be datafilled in table DRMUSERS.
XLA		see subfield	Translations. This field consists of subfield USEXLGRP and refinement.
	USEXLGRP	Y or N	Use translations group. This field enables use of the SPID (field SPID) in the new TOPS translations plan. Enter Y (enable) or N (disable). For value Y, datafill refinement SPIDGRP. The default is N.
	SPIDGRP	name from table SPIDGRP	SPID group. Datafill this field if field USEXLGRP = Y. Enter a SPID group name defined in table SPIDGRP that contains this SPID (field SPID). This group supports the new TOPS translation and screening plan. The group can contain one or more SPIDs.
SPIDCRIT		see subfield	Service provider identifier criterion. This field consists of subfield USECRIT.

**SPIDDB** (continued)**Field descriptions (Sheet 4 of 7)**

<b>Field</b>	<b>Subfield or refinement</b>	<b>Entry</b>	<b>Explanation and action</b>
	USECRIT	N or Y	User criterion. This field indicates if this SPID belongs to a group of SPIDs for use in QMS CT4s. The values are Y (yes) and N (no). If Y, datafill refinement CRIT.
	CRIT	name from table TQSPIDNM	QMS criterion. If field USECRIT = Y, datafill this field. Enter a group name for SPIDs. The name must be datafilled in table TQSPIDNM. This name can be assigned to many SPIDs.
SCRNIDX		0-100	Screen index. This field is an index into table RESTBIL (TA call) table DARSTBIL (DA call). Field SCRNIDX is used when table WSALEOPT field INTER or INTRA contains AOSPID.
BILAGRMT		see subfield AGRMTYPE	Billing agreement. This field consists of subfield AGRMTYPE. This field is examined to determine the type of billing agreement that is in place for the given provider. This field is checked when table TOPSPARM parameter ALL_CALLS_USE_OPR_SVC_AGRMTS is set to N (No).

**SPIDDB** (continued)**Field descriptions (Sheet 5 of 7)**

Field	Subfield or refinement	Entry	Explanation and action
	AGRMTYPE	SELF, OPR SVC, or NONE	<p>Agreement type. This field indicates the type of billing agreement. The values are as follows:</p> <ul style="list-style-type: none"> <li>• SELF - The service provider has its own billing agreements. Datafill refinements CCVAGRMT, BNSAGRMT, and NOSPDERR. The refinement includes a group name for CCV and BNS agreements and a field for error handling when no SPID is returned from the LIDB query.</li> <li>• OPR SVC - The service provider is using the billing agreements already established by the Operator Services wholesaler. No refinements require datafill. The billing agreement groups used to index tables CCVAGRMT and BNSAGRMT are obtained from parameter OPR_SVC_AGRMTS in table TOPSPARM.</li> <li>• NONE - No billing agreement checking is to be performed. No refinements require datafill. This value is used for the following reasons. <ul style="list-style-type: none"> <li>— to allow a default for ONPs from a pre-TOP13</li> <li>— to allow for default datafill when the feature is not SOCed On</li> <li>— to allow for default datafill when TOPSPARM parameter ALL_CALLS_USE_OPR_SVC_AGRMTS is set to Y and individual agreements are irrelevant</li> <li>— to allow screening for billing agreements to be activated on a per SPID or per CIC basis</li> </ul> </li> </ul>

**SPIDDB** (continued)

## Field descriptions (Sheet 6 of 7)

Field	Subfield or refinement	Entry	Explanation and action
			For value NONE, if this feature is SOCed ON and TOPSPARM parameter ALL_CALLS_USE_OPR_SVC_AGRMTS is set to N, checks for billing agreements are not performed and the call is handled as if this feature is SOCed IDLE.
	CCVAGRMT	name from table BAGNAME	Calling card validation agreement. This field is the billing agreement group name associated with the originating party. For an LEC call, this group name is associated with a SPID in table SPIDDB. For a carrier call, this group name is associated with a CIC in table TOPEACAR. The name must be defined in table BAGNAME. This group name is used as part of the index into table CCVAGRMT.
	BNSAGRMT	name from table BAGNAME	Billing number service agreement. This field is the billing agreement group name associated with the originating party. For an LEC call, this group name is associated with a SPID in table SPIDDB. For a carrier call, this group name is associated with a CIC in table TOPEACAR. The name must be defined in table BAGNAME. This group name is used as part of the index into table BNSAGRMT.
	NOSPDERR	ACCPT, BLOCK, or OPER	No AO nor BSP SPID is returned from the LIDB database. Log TOPS12, No Billed AO or BSP SPID Returned, is produced. This field determines error handling with the values as follows: <ul style="list-style-type: none"> <li>• ACCPT—Accept the call.</li> <li>• BLOCK—Block the call.</li> <li>• OPER—Send the call to an operator if the call is not at an operator (that is, at an automated system), or if at an operator, block that billing method and allow the operator to prompt for another method of payment.</li> </ul>

## SPIDDB (continued)

### Field descriptions (Sheet 7 of 7)

Field	Subfield or refinement	Entry	Explanation and action
DACICOVR		Y or N	<p>DACC interlata carrier override. This field is applicable only if all of the following conditions are met:</p> <ul style="list-style-type: none"> <li>The call is an interlata ADACC call.</li> <li>Table TOPSPARM parameter DACC_CIC_OVERRIDE_ENABLE = Y</li> <li>Table TOPSPARM parameter DACC_OVERRIDE_CIC = N</li> </ul> <p>Then, the carrier associated with the call is replaced with the carrier specified in the CARRNO subfield that follows. The values for the DACICOVR field are Y (enable) and N (disable). For Y, datafill subfield CARRNO.</p>
	CARRNO	0000 to 9999	Carrier number. This field appears when field DACICOVR = Y. Enter a carrier to replace the associated interlata ADACC carrier.

### Datafill example

The following example shows sample datafill for table SPIDDB.

### MAP display example for table SPIDDB

SPID	SCRNDISP	DAANN	SPIDCRIT	SCRNIDX	BILAGRMT	OPERSYS	ACTSANN	DACICOVR	TAANN	XLA
OLNS Y	OLNSDSP					ALL Y		OLNSBRAND		
Y	OLNSBRAND	Y		100	ACTSTOPS 25	ACTSTOPS 26	Y	OLNSSPID		
	N				NONE					
DNNSC Y	DNNSCDSP					ALL Y		DNNSCBRAND		
Y	DNNSCBRAND	Y		100	ACTSTOPS 27	ACTSTOPS 28	Y	DNNSCRNSPID		
	N				OPRSVC	Y	1234			

**SPIDDB** (end)**Error messages**

The following error messages apply to table SPIDDB.

**Error messages for table**

Error message	Explanation and action
Allocation of store for table SPIDDB failed.	This error message appears if store cannot be allocated when datafilling table SPIDDB.
No screen display was entered.	This error message appears if Y is entered for SPIDDISP but nothing is entered for DISPLAY (that is, \$ is entered at the DISPLAY prompt).
Branding CLLIs must be datafilled in table ANNS.	This error message is displayed if the entered TACLLI or DACLLI is not datafilled in table ANNS.

**Table history****TOPS14**

Field DACICOVR is added by feature 59021116 in functionality DACC Enhancements I, OSDA0102.

**TOPS13**

Field BILAGRMT is added by feature 59011929 in functionality Screening for Billing Agreement, UNBN0007.

**TOPS12**

The feature Call Restriction for Wholesaling (59006832), which is in functionality UNBN0006, adds SCRNIIDX.

**TOPS09**

The following changes were made:

- Field ACTSANN was added by feature AF7133 in functionality Billing changes, UNBN0001.
- Field XLA was added by feature AF7159 in functionality Translations and routing, UNBN0003.
- Field SPIDCRIT was added by feature AF7160 in functionality Queueing, UNBN0002.

**TOPS07**

Table SPIDDB was introduced by feature AF6711 in functionality Branding via SPID, ENSV0017.



## SPIDGRP

---

### Table name

Service Provider Identifier Group

### Functional description

Table SPIDGRP defines TOPS SPID group names for use by TOPS translations.

### Datafill sequence and implications

There is no requirement to datafill other tables prior to table SPIDGRP.

Table SPIDGRP must be datafilled before tables XLASPID and SPIDDB.

### Table size

0 to 1K words

### Datafill

The following table lists datafill for table SPIDGRP.

#### Field descriptions

Field	Subfield or refinement	Entry	Explanation and action
SPIDGRP		up to 32 alphanumeric characters	Service Provider Identifier Group. Enter an SPID group name for use by TOPS translations.

### Datafill example

The following example shows sample datafill for table SPIDGRP.

#### MAP display example for table SPIDGRP

```
SPIDGRP
-----
ILECXLA
CLECXLA
```

### Table history

#### TOPS09

Initial release by feature AF7159 in functionality Translations and Routing, UNBN0003

## SPINFO

---

### Table name

Service Provider Information

### Functional description

Table SPINFO contains information on each service provider.

The In-session Activation (ISA) service uses table SPINFO to route the call to alternate service providers (ASP).

The Access to Messaging (AMSG) service uses table SPINFO to support alternate messaging service providers for the ASP option.

The Automatic Recall with Name (ARN) service uses table SPINFO to support ARN information for each service provider.

The Talking Call Waiting (TCW) feature using table SPINFO to store the service provider specific information. Multiple tuples can be defined and used by TCW as long as the service provider's name is different. A primary tuple should be defined by default.

The Who's Calling (WC) feature uses table SPINFO to store information specific to service providers. Define multiple ASP tuples for the WC service when using different service provider names. Always define one tuple as the default value.

### Datafill sequence and implications

The following tables are be datafilled before table SPINFO:

- ISAMENU
- IBNFEAT
- KSETFEAT

Table SPINFO must be datafilled after the following tables:

- CLI
- ANNS
- ANNMEMS
- DRAMTRK
- DRMUSERS
- OCCNAME

**SPINFO** (continued)**Table size**

0 through 255 tuples

**Datafill**

The following table lists the ISA datafill for table SPINFO.

**Field descriptions for ISA in table SPINFO**

Field	Subfield	Entry	Explanation and action
SPINFKEY		see subfields	Service provider key. This field consists of subfields PROVNAME and SERVNAME.
	PROVNAME	1-16 alphanumeric characters, PRIMARY, or NIL_PROV	Provider name. This field specifies the name of the service provider. A maximum of 255 service providers is allowed. PRIMARY represents the usual provider for the office.  <b>Note:</b> Although NIL_PROV appears in the range of values, it cannot be used.
	SERVNAME	ISA	Service name. This field specifies the name of the service offered by the service provider, which in this case is ISA.
DATA		see subfields	Data. This field consists of subfields SERVSEL, ENABLED, CARRIER, and BILLINGDN.
	SERVSEL	1-8 alphanumeric characters	Service selector. This field specifies the name of the service, which in this case is ISA. When set to ISA, fields BSYLOCAL, BSYTOLL, RNALOCAL, RNATOLL, and RNATIMER must be datafilled.  <b>Note:</b> The name of the service in this field must be the same as in field SERVNAME.
	ENABLED	Y or N	Enabled. This field indicates whether the service is enabled for the service provider specified in field PROVNAME.
	CARRIER	1-16 alphanumeric characters, or NILC	Carrier. This field specifies the service provider's preferred carrier for toll calls.

**SPINFO** (continued)

**Field descriptions for ISA in table SPINFO (Continued)**

Field	Subfield	Entry	Explanation and action
	BILLNGDN	10-digit directory number, or NILDN	Billing directory number. This field specifies the directory number to which the call is to be charged.
	INTERLAT	Y or N	Inter Local Access and Transport Area. This field allows service on InterLATA calls.
	BSYLOCAL	1-16 alphanumeric characters, or NILMENU	Busy local. This field specifies the menu identifier that corresponds to the announcement to be played when a busy condition is encountered for a local call. When NILMENU is entered, ISA is not invoked.
	BSYTOLL	1-16 alphanumeric characters, or NILMENU	Busy toll. This field specifies the menu identifier that corresponds to the announcement to be played when a busy condition is encountered for a toll call. When NILMENU is entered, ISA is not invoked.
	RNALocal	1-16 alphanumeric characters, or NILMENU	Ring/no answer local. This field specifies the menu identifier that corresponds to the announcement to be played when an RNA condition is encountered for a local call. When NILMENU is entered, ISA is not invoked.
	RNATOLL	1-16 alphanumeric characters, or NILMENU	Ring/no answer toll. This field specifies the menu identifier that corresponds to the announcement to be played when an RNA condition is encountered for a toll call. When NILMENU is entered, ISA is not invoked.
	RNATIMER	12-72	Ring/no answer timer. This field specifies the number of seconds before the ISA announcement is started when an RNA condition is encountered.  <b>Note:</b> This field only appears when the value in either RNALocal or RNATOLL is other than NILMENU.

**SPINFO** (continued)**Datafill**

The following table lists the TCW datafill for table SPINFO.

**Field descriptions for TCW in table SPINFO**

Field	Subfield	Entry	Explanation and action
SPINFKEY		see subfields	Service provider key. This field consists of subfields PROVNAME and SERVNAME.
	PROVNAME	1-16 alphanumeric characters, PRIMARY	Provider name. This field specifies the name of the service provider for the TCW service. A maximum of 255 service providers is allowed. When no ASP is assigned to a line, the value should be set to PRIMARY.
	SERVNAME	TCW	Service name. This field specifies the name of the service offered by the service provider, which in this case is TCW.
DATA		see subfields	Data. This field consists of subfields SERVSEL, ENABLED, CARRIER, and BILLINGDN, BILLING, REGULAR, SDNRING1, SDNRING2, SDNRING3, LDS, DRCW, SCWID, T1, znc T2.
	SERVSEL	TCW	Service selector. This field specifies the name of the service, which in this case is TCW.  <b>Note:</b> The name of the service in this field must be the same as in field SERVNAME.
	ENABLED	Y or N	Enabled. This field indicates whether the service is enabled for the service provider specified in field PROVNAME. To enable TCW, enter Y.
	CARRIER	1-16 alphanumeric characters, or NILC	Carrier. This field specifies the service provider's preferred carrier for toll calls. Valid entries appear in table OCCNAME, or enter NILC for no carrier.
	BILLNGDN	10-digit directory number, or NILDN	Billing directory number. This field specifies the directory number to which the call is to be charged, or enter NILDN for no DN..

**SPINFO** (continued)

**Field descriptions for TCW in table SPINFO (Continued)**

Field	Subfield	Entry	Explanation and action
	BILLING	Y or N	<p>Billing. This field controls the billing on calls placed to the SN. Regular billing will be generated.</p> <p><b>Note:</b></p> <p>It is recommended to datafill a charge DN even if Billing is set to N. If Billing is set to Y, no TRA billing records will be generated on calls to the SN.</p>
	REGULAR	4- to 30-digit DN or \$	<p>Regular. This field contains the DN to route to the SN to provide regular CWT tone.</p> <p>For a regular CWT tone, enter a 4- to 30-digit DN, otherwise enter \$.</p>
	SDNRING1	4- to 30-digit DN or \$	<p>Secondary directory number 1. This field contains the DN to route to the SN to provide enhanced CWT tone 1.</p> <p>For an enhanced CWT tone 1, enter a 4- to 30-digit DN, otherwise enter \$.</p>
	SDNRING2	4- to 30-digit DN or \$	<p>Secondary directory number 2. This field contains the DN to route to the SN to provide enhanced CWT tone 2.</p> <p>For an enhanced CWT tone 2, enter a 4- to 30-digit DN, otherwise enter \$.</p>
	SDNRING3	4- to 30-digit DN or \$	<p>Secondary directory number 3. This field contains the DN to route to the SN to provide enhanced CWT tone 3.</p> <p>For an enhanced CWT tone 3, enter a 4- to 30-digit DN, otherwise enter \$.</p>
	LDS	4- to 30-digit DN or \$	<p>Long distance signal. This field contains the DN to route to the SN to provide the long distanced signal tone.</p> <p>To provide the LDS signal, enter a 4- to 30-digit DN, otherwise enter \$.</p>

**SPINFO** (continued)**Field descriptions for TCW in table SPINFO (Continued)**

Field	Subfield	Entry	Explanation and action
	DRCW	4- to 30-digit DN or \$	Distinctive ringing call waiting. This field contains the DN to route to the SN to provide the distinctive ringing CWT tone.  To provide the DRCW tone, enter a 4- to 30-digit DN, otherwise enter \$.
	SCWID	4- to 30-digit DN or \$	Spontaneous call waiting identification. This field contains the DN to route to the SN to provide the audible name without any CWT tone.  To provide the audible name, enter a 4- to 30-digit DN, otherwise enter \$.
	T1	Integer from 1 to 10	Timer 1. This field contains the time-out value for the T1 timer in seconds.  To provide the time-out value, enter an integer from 1 to 10.
	T2	Integer from 1 to 10	Timer 2. This field contains the time-out value for the T2 timer in seconds.  To provide the time-out value, enter an integer from 1 to 10.

**Datafill**

The following table lists the AMMSG datafill for table SPINFO.

**Field descriptions for AMMSG in table SPINFO**

Field	Subfield	Entry	Explanation and action
SPINFKEY		see subfields	Service provider key. This field consists of subfields PROVNAME and SERVNAME.
	PROVNAME	1-16 alphanumeric characters, PRIMARY, or NIL_PROV	Provider name. This field specifies the name of the service provider. A maximum of 255 service providers is allowed. PRIMARY represents the usual provider for the office.
	SERVNAME	AMMSG	Service name. This field specifies the name of the service offered by the service provider.

**SPINFO** (continued)

**Field descriptions for AMMSG in table SPINFO (Continued)**

Field	Subfield	Entry	Explanation and action
DATA		see subfields	The AMMSG service supports alternate messaging service providers. Data. This field consists of subfields SERVSEL, ENABLED, CARRIER, and BILLNGDN.
	SERVSEL	1-8 alphanumeric characters	Service selector. This field specifies the name of the service. Datafill fields BILLNGDN, INTERLAT, SDSRNA, and SDSBSY.
	ENABLED	Y	Enabled. This field indicates whether the service is enabled for the service provider specified in field PROVNAME.
	CARRIER	1-16 alphanumeric characters, or NILC	Carrier. This field specifies the service provider's preferred carrier for toll calls.
	BILLNGDN	10-digit directory number, or NILDN	Billing directory number. This field specifies the directory number to charge the call.
	INTERLAT	Y or N	Inter Local Access and Transport Area. This field allows service on InterLATA calls.
	SDSRNA	Y or N	Special Delivery Service (SDS) ring/no answer. This field indicates if the service provider has access to messaging for ring/no answer.
	SDSBSY	Y or N	Special Delivery Service (SDS) busy. This field indicates if the service provider has access to messaging for busy condition.



**SPINFO** (continued)**Datafill for table SPINFO-SDSRNA enabled**

Datafill subfields if subfield SDSRNA entry is yes.

**Field descriptions for SDSRNA enabled in table SPINFO**

Field	Subfield	Entry	Explanation and action
	MSGACKKEY	1-9	<p>Message acceptance key. This field specifies the key that end users press to accept access to messaging service on the ring/no answer condition.</p> <p><b>Note:</b> If an end user selects a value of "1", a warning message indicates that this value accepts service offering when using a hookswitch to hang up a call.</p>
	RNATIMER	0-127	Ring/no answer timer. This subfield specifies the number of seconds before ringing/no answer calls receive the announcement, offering access to messaging service.
	MSGANNC	see subfields	Message announcement. This subfield identifies the announcement that offers access to messaging service using the announcement's CLLI code from table CLLI.
	STND	CLLI	This subfield specifies the CLLI for custom announcements. Datafill CLLI in table ANNMEMS.
	CUSTOM	ANNCLLI	This subfield specifies the CLLI for custom announcements. Datafill CLLI in table DRMUSERS.
		ANNID	This subfield specifies which custom announcement to play corresponding to CLLI.
	INTERRNA	A DN with 7, 10 or up to 30 digits	InterLATA ring/no answer. This subfield specifies the message routing DN for interLATA ring/no answer calls.
	INTRARNA	A DN with 7, 10 or up to 30 digits	IntraLATA ring/no answer. This subfield specifies the message routing DN for intraLATA ringing/no answer calls.

**SPINFO** (continued)

**Datafill for table SPINFO-SDSBSY enabled**

Datafill subfields if subfield SDSBSY is Y.

**Field descriptions for SDSBSY enabled in table SPINFO**

Field	Subfield	Entry	Explanation and action
	MSGACKKEY	1-9	Message announcement key. This field specifies the key that end users press to accept access to messaging service on the ring/no answer condition.  <b>Note:</b> This field only appears when the value in either RNALOCAL or RNATOLL is other than NILMENU.
	MSGANNC	see refinements	Message announcement. This subfield identifies the announcement that offers access to messaging service using the announcement's CLLI code from table CLLI.
	STND	CLLI	This subfield specifies the CLLI for custom announcements. Datafill CLLI in table ANNMEMS.
	CUSTOM	ANNCLLI	This subfield specifies the CLLI for custom announcements. Datafill CLLI in table DRMUSERS.
		ANNID	This subfield specifies which custom announcement to play corresponding to CLLI.
	INTERBSY	A DN with 7, 10, or up to 30 digits	InterLATA busy. This subfield specifies the Access to Messaging routing DN for interLATA busy calls.
	INTRABSY	A DN with 7, 10, or up to 30 digits	IntraLATA busy. This subfield specifies the Access to Messaging routing DN for intraLATA busy calls.
	ACBMSGAN	see refinements	Automatic Call Back message announcement. This subfield identifies the announcement that offers a choice of access to messaging service or access to ACB service using the announcement's CLLI code from table CLLI.
	STND	CLLI	This subfield specifies the CLLI for custom announcements. Datafill CLLI in table ANNMEMS

**SPINFO** (continued)**Field descriptions for SDSBSY enabled in table SPINFO (Continued)**

Field	Subfield	Entry	Explanation and action
	CUSTOM	ANNCLLI	This subfield specifies the CLLI for custom announcements. Datafill CLLI in table DRMUSERS.
		ANNID	This refinement specifies which custom announcement to play corresponding to CLLI.
	NIL		There are no additional refinements for the NIL selector value.

**Datafill**

The following table lists the ARN datafill for table SPINFO.

**Field descriptions of ARN in table SPINFO**

Field	Subfield	Entry	Explanation and action
SPINFKEY		see subfields	Service provider key. This field consists of subfields PROVNAME and SERVNAME.
	PROVNAME	1-16 alphanumeric characters, PRIMARY, NIL_PROV	Provider name. This field specifies the name of the service provider. A maximum of 255 service providers is allowed. PRIMARY represents the usual provider for the office.
	SERVNAME	ARN	Service name. This field specifies the name of the service offered by the service provider.  The ARN service supports ARN information for each service provider.
DATA		see subfields	Data. This field consists of subfields SERVSEL, BILLING, SNDN, SNT1, and SNT2.
	SERVSEL	ARN	Service selector. This field specifies the name of the service. Datafill fields BILLING, SNDN, SNT1, and SNT2.
	BILLING	boolean	Billing. This field controls the billing on the calls placed to the service node (SN).

**SPINFO** (continued)

**Field descriptions of ARN in table SPINFO (Continued)**

Field	Subfield	Entry	Explanation and action
	SNDN	4 to 30 digits	Service node directory number. This field contains the DN to route the SN to provide the regular call waiting (CWT) tone.
	SNT1	integer from 1 to 10	Service node timer 1. This field contains the time-out value for the T1 timer ( in seconds).
	SNT2	integer from 10 to 100	Service node timer 2. This field contains the time-out value for the T2 timer (in tenths of seconds).

**Datafill**

The following table lists the WC datafill for table SPINFO.

**Field descriptions of WC in table SPINFO**

Field	Subfield	Entry	Explanation and action
SPINFKEY	PROVNAME	1–16 alphanumeric characters, PRIMARY	This field indicates the name of the provider for the WC service. PRIMARY represents the usual provider for the office.
	SERVNAME	WC	This field identifies the name of the service offered by the service provider.
DATA	SERVSEL	WC	This field is identical to the SERVNAME.
	ENABLED	Y,N	This field indicates whether the service is enabled or disabled for the service provider identified in field PROVNAME.
	CARRIER	1–16 alphanumeric characters, or NILC	This field identifies the service provider's preferred carrier for the calls placed to the service node (SN). Valid entries appear in table OCCNAME, or enter NILC for no carrier.
	BILLINGDN	10-digit DN, or NILDN	This field identifies the DN to bill charges for calls placed to the SN. Enter NILDN to bill charges to the WC subscriber.
	BILLING	Y or N	This field determines if a call to an SN generates a billing record.

**SPINFO** (continued)**Field descriptions of WC in table SPINFO (Continued)**

Field	Subfield	Entry	Explanation and action
	SNDN1	4 to 30 digits DN	Service node directory number. This field contains the DN to route to the SN when the WC subscriber does not have voice messaging on the line.
	SNDN2	4 to 30 digits DN	Service node directory number. This field contains the DN to route to the SN when the WC subscriber has voice mail on the line.
	T1	integer from 1 to 10	This field contains the time-out value for the T1 timer in seconds.
	T2	integer from 10 to 50	This field contains the time-out value for the T2 timer in seconds.
	T4	integer from 10 to 50	This field contains the time-out value for the T4 timer in seconds.

**Datavill example**

The following example shows sample datavill for table SPINFO.

**MAP display example for table SPINFO**

SPINFKEY	DATA
PROV_1	AMSG           AMSG   Y   ACARRIER   5197774321   Y   N   Y
4 STND	PROV_1BSYANNC 5197771234 STND PROV_1ACBMSGAN
	PRIMARY ISA
ISA	Y   UWATS   6136891234   BSY1   NILMENU   RNA2   RNA4   12
	PROV_A   ISA
ISA	Y   NILC   NILDN           BSY1   NILMENU   RNA2   NILMENU   30

The following example shows sample datavill for table SPINFO with TCW service.

**SPINFO** (continued)**MAP display example for table SPINFO with TCW service**

SPINFKEY	DATA
PRIMARY TCW TCW Y UNT2 6137235166 Y 7235222 7235544 7235545 7235546 7235547 7235549 10 100	
PROV1 TCW TCW Y NILSC NILDN N 18195225656 18195225657 18195225657 \$ \$ \$ 4 50	

The following example shows sample datafill for table SPINFO with ARN service.

**MAP display example for table SPINFO with ARN service**

SPINFKEY	DATA
PRIMARY ARN ARN Y NILC NILDN N 51462155555 2 25	
SP1 ARN ARN Y NILC NILDN Y 5146211234 2 25	

The following example shows datafill for table SPINFO with WC service.

**MAP display example for table SPINFO with WC service**

SPINFKEY	DATA
PRIMARY WC WC Y NILC NILDN N 91234567 91234568 5 40 40	
SP00001 WC WC Y NILC NILDN N 91236321 91238321 5 40 40	

## Table history

### NA017

The datafill sequence has changed.

**NA013**

This release affects table SPINFO in the following ways:

- Added WC datafill.
- The common fields SERVNAME and SERVSEL accept WC as a value.
- Added subfields BILLING, SNDN1, SNDN2, T1, T2, and T4, which contain WC service provider information.

**NA012**

This release affects table SPINFO in the following ways:

- The common fields SERVNAME and SERVSEL accept ARN as a value.
- Added subfields BILLING, SNDN, SNT1, and SNT2, which contain ARN service provider information.
- Information for TCW service added.

**NA010**

This release affects table SPINFO in the following ways:

- Added AMMSG datafill.
- Added conditional datafill for refinements SDSBSY and SDSRNA enabled.

**NA006**

Table SPINFO was created.

---

**SPLANILN**

---

**Table name**

Special Automatic Number Identification Line Table

**Functional description**

Table SPLANILN contains the directory numbers (DN) of coin, hotel, coinless public, and restricted coin lines, and identifies these line types to the non-Traffic Operator Position System (TOPS) local access and transport area (LATA) Equal Access System (LEAS). This table is accessed when a non-equal access end office (non-EAEO) cannot provide the correct automatic number identification (ANI) information digit to LEAS when routing calls originating on these lines.

Table SPLANILN is indexed when field SPLOOKUP of table TRKGRP for super centralized automatic message accounting (CAMA) trunks is set to Y (yes). The ten-digit DN of the originating line is the key into this table. If a tuple is found in table SPLANILN for that originating DN, the call is marked as COIN for a coin line, HOT for a hotel line, RSP for a restricted coinless public line, and RSPCO for a restricted coin line. From this identification, the call is routed as if LEAS had received the correct ANI digit from the non-EAEO.

For related information, refer to table DNPIC.

**Datafill sequence and implications**

There is no requirement to datafill other tables prior to table SPLANILN.

**Table size**

0 to 100 000 tuples

A digilator is used to implement table SPLANILN. This structure can require 2 to 100 words of storage for each tuple; however, the average storage requirement is 2 words for each tuple.



**SPLANILN** (continued)**Datafill**

The following table lists datafill for table SPLANILN.

**Field descriptions**

Field	Subfield or refinement	Entry	Explanation and action
DNKEY		see subfield	<i>Directory number</i>  This field consists of subfield DIGILATOR_KEY.
	DIGILATOR_KEY	0 to 9 (2 tables of 3 digits and 2 tables of 2 digits)	<i>Directory number</i>  Enter the value for the directory number (DN), which consists of four parts, equaling ten digits: a three-digit numbering plan area (NPA) code; a three-digit NXX code (station code); and two 2-digit XX codes (line number).
LINEINFO		COIN HOT NOSPLANIL NRSP or RSPCO	<i>Line information</i>  Enter the appropriate line corresponding to the DN of the originating line as follows: <ul style="list-style-type: none"> <li>• COIN for coin line</li> <li>• HOT for hotel line</li> <li>• NOSPLANILN for no special automatic number identification line</li> <li>• RSP for restricted coinless public line</li> <li>• RSPCO for restricted coin line</li> </ul>

**Datafill example**

The following example shows sample datafill for table SPLANILN.

---

**SPLANILN** (end)

---

**MAP display example for table SPLANILN**

DNKEY	LINEINFO
6132281189	COIN
6132288450	HOT
6132456566	COIN
6138411111	RSP
6138419999	RSPCO
6132284578	NOSPLANILN

**Table history****BCS36**

Option NOSPLANILN was added to field LINEINFO.

## SPLDNID

---

### Table name

Traffic Operator Position System Special Directory Number Identification Table

### Functional description

Table SPLDNID lists the directory number (DN) of subscribers with one of the following special teletype (TTY) services:

- AQHTL (autoquote hotel TTY located on the hotel premises). All chargeable and optionally nonchargeable calls from this hotel are recorded on this TTY.
- AQTAC (autoquote time and charge TTY located on the subscriber's premises). An example is a law office recording chargeable calls made on behalf of a client.
- COIN (coin phone). An example is a public telephone with a coin slot located in a hotel.
- DUAQHTL (dial-up autoquote TTY located on the hotel premises). All chargeable and optionally nonchargeable calls from this hotel are recorded on this TTY.
- DUAQTAC (dial-up autoquote time and charge TTY located on the subscriber's premises)
- RSTRCTD (restricted billing class). The operating company can define up to 100 restricted billing classes in table RESTBIL.
- VQHTL (voice-quote hotel located on the operating company's premises). For hotels not equipped with a TTY, all chargeable and optionally nonchargeable calls are recorded on a TTY for voice quotation to the hotel.

### BCSMON DBLOCKS command

The batch change supplement monitoring (BCSMON) system command DBLOCKS provides digit block information as follows:

- the number in use
- the number allocated
- the percentage in use
- the percentage available

The digit block information is for each of the following tables:

- CLSVSCRC.CLSVSCR
- CODEBLK

**SPLDNID** (continued)

- HNPACONT.HNPACODE
- IBNXLA
- LATAXLA
- SPLDNID
- STDPRTCT.STDPRT

**Note:** If a tuple is deleted from table SPLDNID, the deleted DN is cross-referenced with table FXDNMAP. If the deleted tuple has a DN referenced in table FXDNMAP, the following message is displayed on the DMS MAP (maintenance and administration position) video display terminal (VDU):

WARNING: nnnnnnnnnnn IS AN FX OR ACTUAL NUMBER IN TABLE FXDNMAP.  
CORRESPONDING FX OR ACTUAL NUMBER MAY HAVE DIFFERENT  
RESTRICTIONS.

**CAUTION****Possible memory exhaustion**

The operating company runs the risk of exhausting the memory in table SPLDNID if a large number of unbanded entries exist in field SPLDN. It is strongly recommended that entries in field SPLDN be banded. Banding allocates consecutive numbers in uniform memory blocks, thus reducing memory requirements for table SPLDNID. Refer to field SPLDN for an explanation of banded numbers.

**Datafill sequence and implications**

The following tables must be datafilled before table SPLDNID.

- TOPSDEV
- HOBICDEV

**Table size**

Table size is dynamic and is subject to the system's store requirements for digulators.

**SPLDNID** (continued)**Datafill**

The following table lists datafill for table SPLDNID.

**Field descriptions (Sheet 1 of 2)**

<b>Field</b>	<b>Subfield or refinement</b>	<b>Entry</b>	<b>Explanation and action</b>
SPLDN		numeric (1 to 10 digits)	<p>Special directory number. Enter the calling number, or define a range of numbers as explained below, of the hotel (or place) that calls are recorded on the voice quote or auto quote teletype (TTY).</p> <p>Values greater than ten digits are not allowed. The first three digits represent the numbering plan area (NPA), which, as of BCS36, has a range of 200 to 999.</p> <p>Entries can be banded by entering less than ten digits and thus defining a range of all the ten-digit numbers with the leading digits equal to the digits entered. For example, the entry 416452 results in each of the ten-digit numbers (4164520000 through 4164529999) associated with the entries in the remaining fields of this tuple.</p> <p>Individual ten-digit numbers, originally entered individually or by banding, can be deleted subsequently or have data in associated fields changed.</p> <p>A banded entry can be deleted, thus removing all entries in the band.</p>
SPLSEL		see subfield	<p>Special directory number identification selector area. This field consists of subfield SEL.</p>

**SPLDNID** (continued)

## Field descriptions (Sheet 2 of 2)

Field	Subfield or refinement	Entry	Explanation and action
	SEL	APSLOG, AQHTL AQTAC COIN DUAQHTL DUAQTAC NOSPLDNID RSTRCTD or VQHTL	<p>Special directory number identification selector. Enter the type of device associated with the special DN.</p> <p>Enter APSLOG (attendant pay station log) and datafill refinements APSLOG_NUM and NC as described below.</p> <p>Enter AQHTL (autoquote hotel TTY) and datafill refinements AQ_NUM and NC as described below.</p> <p>Enter AQTAC (autoquote time and charge TTY) and datafill refinement AQ_NUM as described on page Section , "SEL = AQTAC" on page -275.</p> <p>Enter COIN (coin phone) and datafill refinements LC_TYPE, ACTS_COMPATIBLE, RESCOIN, and RBILCLAS as described on page Section , "SEL = COIN" on page -275.</p> <p>Enter DUAQHTL (dial-up autoquote hotel TTY) and datafill refinements DUAQ_NUM and NC as described on page Section , "SEL = DUAQHTL" on page -276.</p> <p>Enter DUAQTAC (dial-up autoquote time and charge TTY) and datafill refinement DUAQ_NUM as described on page Section , "SEL = DUAQTAC" on page -277.</p> <p>Enter NOSPLDNID (no special directory number identification); no other datafill is required.</p> <p>Enter RSTRCTD (restricted billing class defined in table BILCLAS) and datafill refinement RBILCLAS as described on page Section , "SEL = RSTRCTD" on page -277.</p> <p>Enter VQHTL (voicequote hotel TTY) and datafill refinement VQHTL as described on page Section , "SEL = VQHTL" on page -277.</p>

**SPLDNID** (continued)**SEL = APSLOG**

If the entry in field SEL is APSLOG, datafill refinements APSLOG\_NUM and NC as described below.

**Field descriptions for conditional datafill**

Field	Subfield or refinement	Entry	Explanation and action
	APSLOG_NUM	0 to 21	APS log number. This field indicates the log number in log APSLOGxx, where xx is the field entry.
	NC	Y or N	No charge calls. Enter Y to record all calls, charge and no charge. No charge calls have no charge or tax on the record. Enter N to record only charge calls. This field does not apply to no answer, no duration calls.

**SEL = AQHTL**

If the entry in field SEL is AQHTL, datafill refinements AQ\_NUM and NC as described below.

**Field descriptions for conditional datafill**

Field	Subfield or refinement	Entry	Explanation and action
	AQ_NUM	0 to 9999	Autoquote device number. TTY associated with this special directory number (DN). This number is the index into table TOPSDEV.  The entry 0 (zero) cannot be datafilled by the operating company.
	NC	Y or N	No-charge calls. Enter Y (yes) to record no-charge calls. Otherwise, enter N (no).

**SPLDNID** (continued)**SEL = AQTAC**

If the entry in field SEL is AQTAC, datafill refinement AQ\_NUM as described below.

**Field descriptions for conditional datafill**

Field	Subfield or refinement	Entry	Explanation and action
	AQ_NUM	1 to 9999	<p>Autoquote device number. Enter the device number for the autoquote TTY associated with this special DN. This number is the index into table TOPSDEV.</p> <p>The entry 0 (zero) cannot be datafilled by the operating company.</p>

**SEL = COIN**

If the entry in field SEL is COIN, datafill refinements LC\_TYPE, ACTS\_COMPATIBLE, RESCOINS, and RBILCLAS as described below.

**Field descriptions for conditional datafill (Sheet 1 of 2)**

Field	Subfield or refinement	Entry	Explanation and action
	LC_TYPE	SPL or STD	<p>Local coin type. Enter the local coin type associated with coin phones.</p> <p>Enter SPL if the coin type is special and the associated nonstandard schedule name and ratestep is used in table LCLRS.</p> <p>Enter STD if the coin type is standard and the associated standard schedule name and ratestep is used in table LCLRS.</p>
	ACTS_COMPATIBLE	ACTS or NOACTS	<p>Automatic coin toll service compatible. Enter ACTS if the coin station DN used to index table SPLDNID is automatic coin toll service compatible.</p> <p>Otherwise, enter NOACTS.</p>



**SPLDNID** (continued)**Field descriptions for conditional datafill (Sheet 2 of 2)**

Field	Subfield or refinement	Entry	Explanation and action
	RESCOIN	Y or N	Restricted coin. Enter Y if the coin line is a restricted coin line. Enter N if the line is a coin line.  The default value is N.
	RBILCLAS	0 to 100	Restricted billing class. Enter a value between 0 and 99 if field RESCOIN has a value of Y.  Enter 100 if field RESCOIN has a value of N.  This number is the index into table RESTBIL.

**SEL = DUAQHTL**

If the entry in field SEL is DUAQHTL, datafill refinements DUAQ\_NUM and NC as described below.

**Field descriptions for conditional datafill**

Field	Subfield or refinement	Entry	Explanation and action
	DUAQ_NUM	1 to 9999	Dial-up autoquote device number. Enter the device number for the autoquote TTY associated with this special DN. This number is the index into table HOBICDEV.  The entry 0 (zero) cannot be datafilled by the operating company.
	NC	Y or N	No-charge calls. Enter Y (yes) to record no-charge calls. Otherwise, enter N (no).

**SPLDNID** (continued)**SEL = DUAQTAC**

If the entry in field SEL is DUAQTAC, datafill refinement DUAQ\_NUM as described below.

**Field descriptions for conditional datafill**

Field	Subfield or refinement	Entry	Explanation and action
	DUAQ_NUM	1 to 9999	Dial-up autoquote device number. Enter the device number for the autoquote TTY associated with this special directory number. This number is the index into table HOBICDEV.  The entry 0 (zero) cannot be datafilled by the operating company.

**SEL = RSTRCTD**

If the entry in field SEL is RSTRCTD, datafill refinement RBILCLAS as described below.

**Field descriptions for conditional datafill**

Field	Subfield or refinement	Entry	Explanation and action
	RBILCLAS	0 to 100	Restricted billing class. Enter the restricted billing class. This number is the index into table RESTBIL.

**SEL = VQHTL**

If the entry in field SEL is VQHTL, datafill refinement NC as described below.

**Field descriptions for conditional datafill**

Field	Subfield or refinement	Entry	Explanation and action
	NC	Y or N	No-charge calls. Enter Y (yes) to record no-charge calls. Otherwise, enter N (no).

**Datafill example**

The following example shows sample datafill for table SPLDNID.

## SPLDNID (end)

---

### MAP display example for table SPLDNID

SPLDN	SPLSEL
4166757611	AQHTL 13 Y
4162415336	AQTAC 21
4167676435	VQHTL Y
9003852211	RSTRCTD 0

### Table history

#### NA009

Add field SEL new value APSLOG by feature AF7161 in functionality Attendant Pay Station, OSB00001.

#### BCS36

The following changes were made to table SPLDNID:

- added to field SPLDN that the range for the NPA (the first three digits of the entry in field SPLDN) is now 200 to 999
- added option NOSPLDNID (no special directory number identification) to field SEL

---

## SPMCHAST

---

### Table name

SPM Messaging Channel Assignment (SPMCHAST)

### Functional description

In the DMS-Spectrum Peripheral Module (SPM), the mapping between C-side and P-side channels are made dynamically. This ability is supported in the common equipment module (CEM) hardware by an internal time switch. In addition, mapping between C-side and P-side channels is not necessarily one-to-one. For example, some C-side channels are used for messaging between the DMS-Bus and the SPM without tying up any P-side channels.

To take advantage of this, a dynamic mapping table is maintained by the channel manager to make efficient use of the channels available. Table SPMCHAST is queried to find the next available channel, then updated when a channel is reserved or freed.

Table SPMCHAST keeps track of current DS0 channels being used for messaging in the SPM. It is implemented as a data table to be dumped and restored on the inactive side as part of the dump and restore process.

When SPM table control is restored on the inactive side, this messaging channel mapping table provides SPM table control with the channels being assigned for messaging. This is required to ensure that identical channels are allocated on the inactive side in preparation for the NORESTART SWACT.

### Datafill sequence and implications

There is no requirement to datafill other tables prior to table SPMCHAST. Its datafill is controlled by the SPM link registration agent.

*Note:* Table SPMCHAST cannot be datafilled by operating company personnel and is not accessible through the table editor.

### Table size

Table size is dynamic and depends on the current configuration of the SPM. Each entry takes 6 bytes. There is a maximum of  $4 \times N$  entries, where N is the number of SPM nodes (maximum 64). However, a normal configuration usually has only one or two SPM nodes.

Minimum size:  $(4 \times 1 \text{ node}) \times 6 \text{ bytes} = 24 \text{ bytes}$

Maximum size:  $(4 \times 64 \text{ nodes}) \times 6 \text{ bytes} = 1536 \text{ bytes}$

**SPMCHAST** (continued)**Field descriptions**

The following table describes field names, subfield names, and valid data ranges for table SPMCHAST.

Field	Subfield or refinement	Entry	Explanation and action
KEY		See subfields	KEY. This field consists of subfields NODE, LINK, and MSG_CHNL. This is the key field to table SPMCHAST.
	NODE	0 to 63	NODE NUMBER. Enter the node number of the SPM node.
	LINK	0 to 97	MESSAGE LINK. Enter the message link number for the node.
	MSG_CHNL	0 to 3	MESSAGE CHANNEL. Enter the message channel number for the node.
START		0-511	START. This field indicates the starting DS-0 channel of the messaging channel. The default value is 0.
BANDWIDT		0-511	BANDWIDTH. This field indicates the number of DS-0 channels in the messaging channel. The default value is 0.
DISTANCE		0-511	DISTANCE. This field indicates the distance between two consecutive DS-0 channels in the messaging channel. The default value is 0.
<p><b>Note:</b> Table SPMCHAST is indexed by the SPM node, link, and messaging channel number.</p>			

**Datafill example**

The following example shows sample datafill for table SPMCHAST.

---

**SPMCHAST** (end)

---

KEY	START	BANDWIDT	DISTANCE
3 90 0	64	7	64
3 91 0	65	7	64
3 92 0	66	7	64
3 93 0	67	7	64
4 90 0	1	7	64
4 91 0	1	7	64
4 92 0	1	7	64
4 93 0	1	7	64
6 90 0	64	7	64
6 91 0	65	7	64

**Table history****SPM01 (CSP09)**

Table SPMCHAST was created.

---

## SPMECAN

---

### Table name

SPM Echo Cancellor (SPMECAN)

### Functional description

Table SPMECAN is used to provision the DMS-Spectrum Peripheral Module (SPM) echo canceller (ECAN) control parameters.

### Datafill sequence and implications

There is no requirement to datafill other tables before table SPMECAN.

A tuple in this table can be referenced by any number of tuples in table TRKSGRP. To delete a tuple from table SPMECAN, there must be no reference to it in table TRKSGRP.

Tables must be datafilled in the following sequence:

- SPMECAN
- MNNODE

### Table size

Table SPMECAN holds a maximum of 256 tuples (0 to 255).

Size of one tuple =7 bytes

Minimum size of table = 0 Kbytes

Maximum size of table =  $256 \times 7 = 1.75$  Kbytes

### Field descriptions

The following table describes field names, subfield names, and valid data ranges for table SPMECAN.

Field	Subfield or refinement	Entry	Explanation and action
ECINDEX		0-255	ECHO CANCELLER INDEX. This field is the key.
TONDS		Y or N	tone DISABLER. The TONDS bit enables or disables the tone disable. Enter Y (default) to disable the echo canceller upon receipt of a valid G.164 or G.165 tone from the near or far end.

**SPMECAN** (continued)

Field	Subfield or refinement	Entry	Explanation and action
TONMG		Y or N	<p>TONE MESSAGE. Enter Y (default) to send messages to the SPM resource manager every time the echo canceller is disabled by a valid G.164 or G.165 tone or enabled by silence below the specified threshold for ~300ms.</p> <p><b>Note:</b> AUTON parameter must be set to 1 for the echo canceller to be enabled again after being disabled by the tone.</p>
TONEDMOD		G164 or G165	<p>TONE DISABLER MODE. Enter G164 to use the G.164 tone disabler mode. Enter G165 (default) to use the G.165 tone disabler mode.</p> <p><b>Note:</b> The only difference between G.164 and G.165 is the additional requirement for G.165. Specifically, the disabling tone must contain phase reversals to be detected.</p>
S56KB		Y or N	<p>SIGNAL 56 KILOBYTES. Enter Y to enable the 56 Kbyte/s mode for tone disabler. The default is N.</p> <p><b>Note:</b> This mode is used for data transfer. In the switched 56 Kbyte/s traffic mode, the least significant bit (LSB) of every frame is set to 1 for a busy circuit. The echo canceller is initially disabled by the detection of tone and remains disabled as long as an "all 1's" pattern is maintained. Following a violation of "all 1's" pattern, the echo canceller is enabled again when signal energy falls below the specified threshold.</p>
AUTON		Y or N	<p>AUTOMATIC ON. Enter Y (default) to again enable the echo canceller when signal energy falls below a specified threshold.</p>
NLP		Y or N	<p>CENTER CLIPPER. Enter Y (default) to enable the center clipper. The center clipper operates on residual echoes in the absence of near-end speech paths—this improves the ERLE after convergence.</p>



**SPMECAN** (continued)

<b>Field</b>	<b>Subfield or refinement</b>	<b>Entry</b>	<b>Explanation and action</b>
NSMAT		Y or N	NOISE MATCHING. Enter Y (default) to enable noise matching. This function is active only if NLP is enabled. When the output signal from the echo canceller falls below a specified suppression threshold, it is replaced by white noise at the threshold level.
SOS		Y or N	SOS. Enter Y (default) to allow the ECAN to send SOS messages when the echo canceller cannot achieve the specification within a reasonable amount of time.
TDINC		Y or N	Enter Y (default) to enable the automatic increment of MDLA (maximum tail delay) when convergence cannot be achieved with the current setting. When field TDINC is set to Y, the normal SOS message is not sent when convergence is impossible; the MDLA is incremented to 128 ms. If the MDLA parameter is already 128 ms and convergence is still impossible, an SOS message is sent.
MDLA		16MS, 32MS, 48MS, 64MS, 80MS, 96MS, 112MS, 128MS	MAXIMUM TAIL DELAY. This field sets the maximum tail delay recognized. Echoes with a delay greater than the maximum tail delay are not recognized. The default value is 32MS.
MERL		0DB, 3DB, 6DB	MINIMUM ERL. This field contains the minimum expected ERL (echo return loss). The default value is 6DB.
ACOM		20DB TO 70DB	COMBINED LOSS. This field enables customers to specify the expected limit of Combined Loss on a trunk subgroup basis. When the Combined Loss is less than the value of datafilled ACOM for a call, information on the suspect EC is documented in the SPM660 log The default value is 33DB.

**SPMECAN** (continued)

Field	Subfield or refinement	Entry	Explanation and action
FAREC		Y or N	FAR END ECHO CANCELLER. Enter Y if an external echo canceller is present at the far end. The default value is N.  <b>Note:</b> FAREC and BK2BK fields cannot both be assigned a value of Y at the same time.
BK2BK		Y or N	BACK TO BACK. Enter Y to allow two ECANs to be hooked in back-to-back configuration. The default value is N.  <b>Note:</b> FAREC and BK2BK fields cannot both be assigned a value of Y at the same time.
S2COMPAT		S2C_NONE, S2C_NORM, S2C_REV	MMP series 2 peripheral compatibility mode. Enter S2C_NONE to retain the expected SPM behavior in all non-MMP loads. Enter S2C_NORM for the SPM to replicate the MMP echo canceller behavior of series 2 peripherals in normal mode. Enter S2C_REV for the SPM to replicate the MMP echo canceller behavior of series 2 peripherals in reverse connected mode. The default value is S2C_NONE.
EC_BYTE_1		00-FF	This hex byte #1 applies to a third party echo canceller. By default, it is set to 00.
EC_BYTE_2		00-FF	This hex byte #2 applies to a third party echo canceller. By default, it is set to 00.
EC_BYTE_3		00-FF	This hex byte #3 applies to a third party echo canceller. By default, it is set to 00.
EC_BYTE_4		00-FF	This hex byte #4 applies to a third party echo canceller. By default, it is set to 00.

**Datafill example**

The following example shows sample datafill for table SPMECAN. Note that most of the fields in the table are of type Boolean.

**SPMECAN** (continued)

ECINDEX	TONDS	TONMG	TONEDMOD	S56KB	AUTON	NLP	NSMAT	SOS	TDINC	MDLA	MERL
ACOM	FAREC	BK2BK	EC_BYTE_1	EC_BYTE_2	EC_BYTE_3	EC_BYTE_4					
0	Y	Y	G165	N	Y	Y	Y	Y	Y	128MS	6DB
	33DB	N	N	00	00	00	00	00			
1	Y	Y	G165	N	Y	Y	Y	Y	Y	32MS	6DB
	25DB	N	N	00	00	00	00	00			
10	Y	Y	G164	N	Y	Y	Y	Y	Y	64MS	6DB
	40DB	N	N	00	00	00	00	00			

**Supplementary information**

If an attempt is made to delete a tuple in table SPMECAN which is referenced in table MNNODE, the attempt is rejected with the following error message:

```
CANNOT DELETE THIS TUPLE - IT IS USED BY SPM 14 IN TABLE MNNODE.
```

**Dump and restore**

If the SPMECAN table is not present on the dump side, but is present on the restore side, it will come up empty on the restore side after the one-night process (ONP). If table SPMECAN is present on both the dump and restore sides prior to ONP, it will be restored before table TRKSGRP.

**Inter table dependencies**

Inter table dependencies are as follows:

- An index is allowed in table TRKSGRP only if it already exists in table SPMECAN.
- If an index is being used by a trunk in table TRKSGRP, it cannot be deleted from table SPMECAN.
- The FAREC and BK2BK fields cannot both be assigned a value of Y in the same tuple instance.

**Table history****SN06 (DMS)**

Tuples in MNNODE may reference table SPMECAN tuples.

**SP15 (CSP15)**

Added field S2COMPAT to table SPMECAN, a new datafill example and new error messages, to implement series 2 echo cancellation compatibility.

**SP14 (CSP13/14)**

Changed information on tuple and table size based on SR 60329736.

**SPMECAN** (end)

---

**SP11 (CSP11)**

Added ACOM (Combined Loss) field to table SPMECAN.

**SPM01 (CSP09)**

Table SPMECAN was created.

---

## SPMLDVAL

---

### Table name

Spectrum Load Name Validation (SPMLDVAL)

### Functional description

Table SPMLDVAL stores the device load sequence for different releases of the TDM spectrum peripheral module (SPM) loads.

The key for table SPMLDVAL is a combination of four parts as follows:

- Spectrum family load type indicator
- General release number
- Maintenance release number
- Emergency release number

The following applications retrieve data from table SPMLDVAL:

- The CI tool SPMLDINFO gets the load sequence information for different SPM load releases from table SPMLDVAL
- The command QUERYPM FILES compares the device loads in a DMS Call Processing (DMSCP) SPM with the load sequence of different SPM load releases datafilled in table SPMLDVAL in order to display the release load running on that SPM

The following notes apply:

**Note 1:** Table SPMLDVAL datafill is only applicable to DMSCP SPM release loads.

**Note 2:** For DMSCP SPMs, if table SPMLDVAL is not datafilled, the CI tool SPMLDINFO and the QUERYPM command display a warning that the SPM load lineup does not match datafill in table SPMLDVAL.

### Datafill sequence and meaning

Table SPMLDVAL can be datafilled in the following ways:

- During peripheral module upgrade automation initiative (PANTHER) execution, if at least one DMSCP SPM node is provisioned in the office, the table SPMLDVAL is datafilled automatically during the PANTHER filecopy step. For offices with Succession Multi-Services Gateway 4 (SMG4), Interworking (IW), or Dynamic Packet Trunk (DPT) SPMs but no DMSCP SPMs, the table is not datafilled during PANTHER execution.
- If tuples need to be added manually, then the administrator can use the **RWOK ON** option to enable write permission for the table

## SPMLDVAL (continued)

Table SPMLDVAL does not have any dependencies on other table datafills.

### Table size

The table gives SPMLDVAL table size information.

Table name	Minimum tuples	Maximum tuples	Memory information
SPMLDVAL	0	255	Protected memory

### Datafill

The table that follows lists fields for table SPMLDVAL and their description.

#### Field descriptions

Field	Entry	Explanation and action
LOAD_TYPE	SP	Spectrum family load type indicator.
GEN_REL	1 to 99	General Release. Enter the milestone release number of the load.
MTC_REL	0 to 9	Maintenance Release. Enter 0 if the load is a general release.
EMG_REL	0 to 9	Emergency Release. Enter 0 if the load is a general release or maintenance release.
LOADLIST	List of up to 32 device loads.	Enter up to 32 valid device load names. Each load name is 7 character long.

### Datafill examples

The table below shows sample datafill for table SPMLDVAL.

```

SP 15 2 1 (COT15BW) (DLC15CY) (DSP15DM) (OC315DD) $
SP 15 3 1 (CEM15CQ) (DSP15DO) (DLC15DA) (OC315DF) $
SP 15 3 2 (CEM15CS) (COH0015) (CST15BH) (DL215AN) (DLC15DB)
(DSP15DP) (OC315DG) (STM15CR) $
SP 15 4 1 (CEM15CV) (COH0015) (CST15BJ) (DL215AO) (DLC15DC)
(DSP15DQ) (OC315DH) (STM15CS) $
SP 16 0 0 (CEM16BP) (COH0016) (DLC16DE) (DL216CW) (DSP16CU)
(CST16CU) (OC316DP) (SYN16BS) $
    
```

**Note:** Pre-Patched SPM Loads (PPSLs) are listed under the current maintenance release name.

---

**SPMLDVAL** (continued)

---

**Table history****SN06 (DMS)**

Table SPMLDVAL was introduced by feature number A89007535.

**SNH01**

Table SPMLDVAL was created by feature A89007535.

**Additional information**

This section provides additional information on table SPMLDVAL.

**Translation and verification**

Table SPMLDVAL does not use translation verification tools.

**Protection level**

The protection level of table SPMLDVAL is SYSPROT. This level prevents adding, deleting or modification of tuples in this table directly. To activate write permission enter the command:

```
> RWOK ON
```

**Error conditions**

During datafill the following error conditions can occur:

- If the same loadname is repeated in a tuple, then the tuple addition will be rejected with the following error message:

```
ERROR: Loadname <loadname> is repeated in the tuple.
```

- If the length of any of the loadname entered is not 7 characters, then the tuple addition is rejected with the following message:

```
ERROR: Loadnames must be 7 characters in length.
```

- Whenever a tuple with 32 or more loadnames are added, the following warning message is displayed to the user:

```
WARNING : 32 loadname entries accepted. Any additional  
loadname entries will be discarded.
```

If a tuple with more than 32 loadnames is added in the table, it will take only the first 32 loadnames entered and discard the remaining entries.

- If the table is already full, then addition of a new tuple will fail with the following message:

```
TABLE IS FULL.
```

#### 4 Data schema tables

---

**SPMLDVAL** (end)

---



---

**SPMROUTE**

---

**Table name**

Service Peripheral Module Routing Table

**Functional description**

Table SPMROUTE routes service peripheral module (SPM) calls to the correct trunk group that associates with an SPM. This table provides a trunk group from which you can reserve different trunk members. This action allows an SPM to originate calls.

**Datafill sequence and meaning**

Enter data in table SPMROUTE before you enter data in the following tables.

- EXNDINV
- TRKGRP
- OFRT
- OFR2
- OFR3
- OFR4
- IBNRTE
- IBNRT2
- IBNRT3
- IBNRT4

**Table size**

0 to 32 tuples

**SPMROUTE** (continued)**Datafill**

Datafill for table SPMROUTE appears in the following table.

**Field descriptions (Sheet 1 of 2)**

Field	Subfield or refinement	Entry	Description
SPMNUM		0 to 31	<i>Service peripheral module number.</i> This field is the key to table SPMROUTE. This field identifies the service peripheral module (SPM) associated with a customer on a terminating call. This action allows the system to present the call to the SPM. This action allows an SPM to associate with voice links. Enter the SPM in table EXNDAPPL before you enter data in this table.
OPTIONS		see subfield	<i>Options.</i> This field specifies the call types allowed over SPM voice links. This field is a vector of a maximum of two multiples of subfield OPTION and refinements. A blank space must separate each entry. If you require less than two multiples, end the list with a \$ (dollar sign).
	OPTION	ORIG or TERM	<i>Call type option.</i> If the call is an originating call, enter ORIG. Enter data in refinement CLLI to specify the trunk group.  If the call is a terminating call, enter TERM. Enter data in refinement EXTRTEID to specify the external route identifier.
	CLLI	alphanumeric (1 to 16 characters)	<i>Common language location identifier.</i> If the entry in subfield OPTION is ORIG, enter data in this refinement. Enter a common language location identifier (CLLI) name to specify the trunk group for the originating call. This name must be a correct trunk group identifier from table TRKGRP. You can use each CLLI name one time in table SPMROUTE. A CLLI that you enter for option ORIG must have a trunk group type of ASP.

**SPMROUTE** (continued)**Field descriptions (Sheet 2 of 2)**

Field	Subfield or refinement	Entry	Description
	EXTRTEID	see subfield	<i>External route identifier.</i> If the entry in subfield OPTION is TERM, enter data in this refinement. This refinement contains subfield TABID and refinement KEY. This refinement must be a correct route reference indicator.
	TABID	IBNRTE IBNR2 IBNR3 IBNR4 OFRT OFR2 OFR3 or OFR4	<i>Table name.</i> Enter the name of the table to which the system must route the translation. Table names other than the names in the list are not correct entry values.
	KEY	0 to 1023	<i>Key.</i> Enter the route reference index in the specified table to which the system must route the translation.

**Datafill example**

Sample datafill for table SPMROUTE appears in the following example.

**MAP example for table SPMROUTE**

SPMNUM	OPTIONS
1	(ORIG SPMTRKS1) (TERM OFRT 100)\$

**Table history****BCS35**

Table SPMROUTE was introduced in BCS35.

**Additional information**

This section provides additional information about table SPMROUTE.

## **SPMROUTE** (end)

---

### **Dump and restore procedures**

The normal dump and restore procedure applies for table SPMROUTE.

---

**SPMTIDMP**

---

**Table name**

SPM Terminal Identification Mapping (SPMTIDMP)

**Functional description**

To support dynamic mapping between external terminals and DS0 channels in the DMS-Spectrum Peripheral Module (SPM), a terminal mapping table is maintained by the Spectrum central channel manager. Table SPMTIDMP records the current mapping from terminal identifications (TID) to channels on the serial links.

**Datafill sequence and implications**

There is no requirement to datafill other tables prior to table SPMTIDMP.

Table SPMTIDMP cannot be datafilled by operating company personnel. Its datafill is controlled by the operations, administration, and maintenance (OAM) provisioning software.

**Table size**

Table size is dynamic and depends on the current configuration of the SPM. Each entry takes 3 bytes. There is a maximum of  $N \times K$  entries, where  $N$  is the number of SPM nodes (maximum of 64) and  $K$  is the maximum number of terminals for each SPM (maximum of 4096 for all nodes in a DMS system).

Although there is a maximum of 64 SPM nodes, a normal configuration usually has only one or two SPM nodes.

Minimum size: 0 byte

Maximum size:  $64 \text{ nodes} \times 4096 \text{ terminals} \times 1 = 262144 \text{ bytes}$

For the OC-3 SPM, there are 2016 terminals. Its calculation is as follows:

$2016 \text{ terminals} \times 3 \text{ bytes} = 6048 \text{ bytes per SPM node}$

**SPMTIDMP** (end)

**Field descriptions**

The following table describes field names, subfield names, and valid data ranges for table SPMTIDMP.

Field	Subfield or refinement	Entry	Explanation and action
KEY		See subfields	KEY. This field consists of subfields NODE and TERM_NO. This the key field to table SPMTIDMP.
	NODE	0 to 63	NODE. Enter the number for the SPM node.
	TERM_NO	0 to 4095	TERMINATION NUMBER. Enter the external termination number of the SPM node.
SLINK1		0 to 89	FIRST SERIAL LINK. The default value is 0.
SLINK2		0 to 89	SECOND SERIAL LINK. The default value is 0.
CHANNEL		0 to 255	CHANNEL NUMBER ON BOTH SERIAL LINKS. The default value is 0.

**Datafill example**

The following example shows sample datafill for table SPMTIDMP.

KEY	SLINK1	SLINK2	CHANNEL	
3	1	19	28	0
3	2	18	27	11
3	3	20	29	21
3	4	19	28	32
3	5	18	27	43
3	6	20	29	53
3	7	19	28	64
3	8	18	27	75
3	9	20	29	85
3	10	19	28	96

**Table history**

**SPM01 (CSP09)**

Table SPMTIDMP was created.

**SPMTKMEM****Table name**

Service Peripheral Module Trunk Member Table

**Functional description**

Table SPMTKMEM maps trunk members to identifiers that are compatible with a service peripheral module (SPM). The operating company can configure each SPM with a maximum of 192 ports. Each voice link identifier corresponds to a port number on the SPM. This table includes the SPM number to make sure that the voice link identifier (VLID) is different from all other VLIDs.

**Datafill sequence and meaning**

Enter data in the following tables after you enter data in table SPMTKMEM.

- EXNDINV
- CLLI
- EXTRKNM

**Table size**

0 to 6144 tuples

You can determine the maximum size of table SPMTKMEM. To perform this action, multiply the maximum entry value for field SPM by the maximum entry value for field VLID.

**Datafill**

Datafill for table SPMTKMEM appears in the following table.

**Field descriptions (Sheet 1 of 2)**

Field	Subfield or refinement	Entry	Description
SPMTKKEY		see subfields	<i>Table key.</i> This field is the key to table SPMTKMEM. This field contains subfields CLLI and MEMNAME. Table TRKMEM must already contain each key entry in this field.
	CLLI	alphanumeric (1 to 16 characters)	<i>Common language location identifier.</i> Enter the common language location identifier (CLLI) for the required trunk group. Enter this CLLI in table TRKGRP for group type ASP.

**SPMTKMEM** (end)

**Field descriptions (Sheet 2 of 2)**

Field	Subfield or refinement	Entry	Description
	MEMNAME	numeric (0 to 9999)	<i>Trunk member name.</i> Enter an external trunk group member number.
SPMNUM		numeric (0 to 31)	<i>Service peripheral module number.</i> Enter a numeric value to specify the SPM that connects to this trunk member. Table EXNDINV must already contain this SPM number.
VLID		numeric (1 to 192)	<i>Voice link identifier.</i> Enter an SPM voice link number or port to which the trunk member maps.

**Datafill example**

Sample datafill for table SPMTKMEM appears in the following table.

**MAP example for table SPMTKMEM**

SPMTKKEY	SPMNUM	VLID
COVMGRP1	1	10 191
COVMGRP2	2	10 190

**Table history**

**BCS36**

Field EXTRKNM was changed to field MEMNAME in BCS36.

**BCS35**

Table SPMTKMEM was introduced in BCS35.

**Additional information**

This section provides additional information related to table SPMTKMEM.

**Dump and restore procedures**

The standard dump and restore procedure applies for this table.



---

**SRASCRN**

---

**Table name**

Suppressed Ringing Access Screening (SRASCRN)

**Functional description**

The SRA feature introduces table SRASCRN. This table contains additional security screening information that the SRA feature uses. Each SRA routing DN tuple in table DNROUTE can have indices to this table and several SRA routing DN tuples can use the same screening lists datafilled in table SRASCRN.

Table DNROUTE and SRASCRN are inter-dependent, therefore a tuple in table SRASCRN can only be deleted if there is no reference to this tuple in table DNROUTE.

**Datafill sequence and implications**

Table SRASCRN must be datafilled before table DNROUTE when SRA DNROUTE tuples reference SRASCRN tuple. If table SRASCRN references customer groups then it must be datafilled after table CUSTENG.

**Table size**

The minimum size of table SRASCRN is 0 tuples and the maximum size is 255 tuples (1 tuple = 82 bytes). No CCrestart type is required in order to increase size.

**Datafill**

Each tuple in table SRASCRN can hold up to either 10 DNs, 10 BGids, or 10 customer group names. Each SRA RoutingDN tuple in table DNROUTE can have up to 30 indices to table SRASCRN, therefore the screening list for a particular Routing DN can be up to 300 DNs, 300 BGids, or 300 customer group names. The following table lists datafill for table SRASCRN.

## SRASCRN (continued)

The following table lists datafill for table Table SRASCRN.

### Field descriptions

Field	Subfield or refinement	Entry	Explanation and action
INDEX		Character string (1 to 16 characters)	<i>Index</i> This field is the key of SRASCRN. The index can be referenced by SRADNROUTE tuples. There is no default.
SECURITY			<i>Security Type</i> This field identifies the kind of security that is used for a RoutingDN. The SRA feature provides three different security mechanisms: DN, BG, and CG. There is no default.
	DN	A list of up to 10 different DNs.	If DN is specified a list of DNs is stored in the security list field.
	BG	A list of up to 10 BGids.	If BG is specified a list of BGids is stored in the security list field.
	CG	A list of up to 10 customer groups.	If CG is specified a list of customer group names is stored in the security list field.  <b>Note:</b> If customer groups are added to table CUSTENG specifically for the SRA feature, then table CUSTENG must be datafilled first.

### Datafill example

The following example shows sample datafill for table Table SRASCRN.

### MAP display example for table SRASCRN

INDEX	SCRNLIST		
STRING1	DN	(6136210000)	(5147221111) \$

**Table history**

**NA009**

Information about table SRASCRN was added.

**NA004**

Table SRASCRN was introduced.

## SRDBXFER

---

### Table name

Selective Routing Database File Transfer Scheduler Table

### Functional description

Table SRDBXFER provides a method of monitoring selective routing database statistics. The table provides this function in two ways:

- For incoming tuples, the table indicates which DMS device that Kermit uses to store RC (recent change) files transferred to the DMS, and whether the error file is erased after the transfer to the ALI (automatic location identifier) database. The transfers to ALI are initiated by the remote ALI. A maximum of two incoming tuple can be specified.
- For each outgoing tuple, an RC file transfer is scheduled from the ALI database to the SRDB (selective routing database) on the DMS. These file transfers are initiated by DMS software.

### Datafill sequence and implications

The following tables must be datafilled before table SRDBXFER.

- MPC
- MPCLINK

### Table size

0 to 6 tuples

**SRDBXFER** (continued)**Datafill**

The following table lists datafill for table SRDBXFER.

**Field descriptions**

Field	Subfield or refinement	Entry	Explanation and action
KEY		see subfield	<i>Table key</i> This field is the key to the table and consists of subfield NAME.
	NAME	alphanumeric (1 to 8 characters)	<i>Key name</i> Enter the unique identifier of the tuple in this table. The table key is used by the command interpreter (CI) command SRDBREQ (selective routing database request), in order to identify a tuple in this table and find information relating to that tuple.
XFERDATA		see subfield	<i>File transfer data</i> This field consists of subfield DIRECT.
	DIRECT	INCOMING or OUTGOING	<i>Direction</i> Enter INCOMING for MPC (multiprotocol controller) links that are monitored for Kermit commands from a remote automatic location identification (ALI) database. Datafill refinements SAVEDEV, MPC, MPCLINK, and ERASERC.  Enter OUTGOING, for MPC links that the DMS uses to perform scheduled file transfers from a remote ALI. Datafill refinements SCHEDULE, REQFILE, CONNTYPE, SAVEDEV, MPC, MPCLINK, UPDATE, ERASERC, CONNFILE, CONNDEV, and ENABLED.  INCOMING links must be dedicated. OUTGOING links can be either dedicated or dial-up.

**SRDBXFER** (continued)**DIRECT = INCOMING**

If the entry in subfield **DIRECT** is **INCOMING**, datafill refinements **SAVEDEV**, **MPC**, **MPCLINK**, and **ERASERC** as described below.

**Field descriptions for conditional datafill**

<b>Field</b>	<b>Subfield or refinement</b>	<b>Entry</b>	<b>Explanation and action</b>
	SAVEDEV	alphanumeric (1 to 20 characters)	<i>DMS file storage device</i>  Enter a DMS file storage device name. The files can be stored in memory, on a tape unit, or on a hard disk drive.  For example, SFDEV for memory, T0 for magnetic tape drive (MTD), or D000VOL99 for a disk drive unit (DDU).
	MPC	0 to 255	<i>Multiprotocol controller number</i>  Enter the number of the MPC used for file transfers. This MPC number must be datafilled in field MPCNO in table MPC.
	MPCLINK	0 to 3	<i>Multiprotocol controller link number</i>  Enter a link number of the MPC used for file transfers. This number must be datafilled in field LINKNO in table MPCLINK as asynchronous and must match the settings of the modem it is connected to. Incoming tuples cannot use the same MPC link.
	ERASERC	Y or N	<i>Erase recent change</i>  Enter Y (yes) if the RC (recent change) files and error message files are to be erased after the inbound file transfer session has finished using them. Otherwise, enter N (no).

**DIRECT = OUTGOING**

If the entry in subfield **DIRECT** is **OUTGOING**, datafill refinements **SCHEDULE**, **REQFILE**, **CONNTYPE**, **SAVEDEV**, **MPC**, **MPCLINK**,

**SRDBXFER** (continued)

UPDATE, ERASERC, CONNFILE, CONNDEV, and ENABLED as described below.

**Field descriptions for conditional datafill (Sheet 1 of 3)**

<b>Field</b>	<b>Subfield or refinement</b>	<b>Entry</b>	<b>Explanation and action</b>
	SCHEDULE	see subfields	<i>File transfer schedule</i> This field consists of subfields PERIOD and TIME.
	PERIOD	DAILY or WEEKLY	<i>File transfer time period</i> Enter DAILY for daily file transfers. Enter WEEKLY for weekly file transfers. Refinement DAY must be datafilled if the WEEKLY period is chosen.
	TIME	0 to 9 (4 digits)	<i>Time of day</i> Enter the time of day when the file transfer takes place in the 24-h format (hhmm).
	DAY	MON, TUE, WED, THU, FRI, SAT, or SUN	<i>Day of the week</i> If the entry in subfield PERIOD is WEEKLY, datafill this refinement. Enter the day of the week used for weekly file transfers.
	REQFILE	TODAY or YESTERDAY	<i>Recent change file request</i> Enter the day that the RC (recent change) file is requested for.
	CONNTYPE	DEDICATED or DIALUP	<i>Connection type</i> Enter DEDICATED, if the connection to the ALI database is a dedicated link. Enter DIALUP for access to the ALI database using a dial-up modem connection.
	SAVEDEV	alphanumeric (1 to 20 characters)	<i>DMS file storage device</i> Enter a DMS file storage device name. The files can be stored in memory, on a tape unit, or on a hard disk drive.  For example, SFDEV for memory, T0 for magnetic tape drive (MTD), or D000VOL99 for a disk drive unit (DDU).

**SRDBXFER** (continued)

## Field descriptions for conditional datafill (Sheet 2 of 3)

Field	Subfield or refinement	Entry	Explanation and action
	MPC	0 to 255	<p><i>Multiprotocol controller number</i></p> <p>Enter the number of the MPC used for file transfers. This MPC number must be datafilled in field MPCNO in table MPC.</p>
	MPCLINK	0 to 3	<p><i>Multiprotocol controller link number</i></p> <p>Enter the link number of the MPC used for file transfers. This MPCLINK number must be datafilled in field LINKNO in table MPCLINK. This link must be datafilled as asynchronous, and the link must also match the settings of the modem it is connected to.</p>
	UPDATE	Y or N	<p><i>Recent change file update</i></p> <p>Enter Y (yes) for updating the selective routing database, after the RC file is received by the scheduler/monitor process. Otherwise, enter N (no).</p>
	ERASERC	Y or N	<p><i>Erase recent change</i></p> <p>Enter Y if the RC files and error message files are to be erased, after the inbound file transfer session has finished using them. Otherwise, enter N.</p> <p><b>Note:</b> An erase occurs only if an update is performed.</p>
	CONNFILE	alphanumeric (1 to 16 characters)	<p><i>Connection script command filename</i></p> <p>Enter a filename that is used as a script (the sequence and dialogue of the communication protocol) file for modem and Kermit commands. When a connection is made, this file is read by the process and each command is executed in the order listed in the file. The connection script file can be used to perform a connection to the ALI database, and request the transfer of the recent change file using Kermit.</p>



**SRDBXFER** (continued)**Field descriptions for conditional datafill (Sheet 3 of 3)**

Field	Subfield or refinement	Entry	Explanation and action
The format restrictions for the command script file are:			
<ul style="list-style-type: none"> <li>• only one command is allowed on each line in the file</li> <li>• all commands and parameters must be in uppercase letters</li> <li>• blank lines and leading spaces are ignored</li> <li>• the line length must be less than 80 characters</li> <li>• the last command in the file must be QUIT</li> </ul>			
<b>Note:</b> This script file must not be moved or erased after datafilling table SRDBXFER. Errors result in the schedule processing if the script file is not set up as described above.			
	CONNDEV	alphanumeric (1 to 20 characters)	<i>Connection device</i> Enter the name for the DMS file device containing the script file.
	ENABLED	Y or N	<i>Schedule run switch</i> Enter Y if the scheduler/monitor system is to run. Enter N if the scheduler/monitor system is not to run.

**Datafill example**

The following example shows sample datafill for table SRDBXFER.

**MAP display example for table SRDBXFER**

KEY	XFERDATA
__INCOMALI	INCOMING D000TEST 1 3 Y

**Supplementary information**

This section provides information on error messages when datafilling table SRDBXFER.

If datafilling of table SRDBXFER is attempted before datafilling tables MPC and MPCLINK, the following error message appears:

**SRDBXFER** (end)

---

MPC (OR MPCLINK) NOT DATAFILLED IN TABLE MPC (OR MPCLINK)

If an attempt is made to datafill two tuples on the same link (field MPCLINK) the following message is output:

BOTH INCOMING TUPLES MAY NOT USE THE SAME MPC LINK

**SRVRS****Table name**

TOPS Service Rating Table

**Functional description**

Table SRVRS allows a schedule and rate step to associated with a tariff and service name combination. The rating is defined by the customer.

Since no rating is made for a toll-free call, this rating type cannot appear in table SRVRS. If a toll-free number is dialed from a hotel or a coin phone, it bypasses operator handling in the same way that directory assistance (DA) calls bypass operators in areas that do not charge for DA services.

Table SRVRS is optional in the standard Traffic Operator Position System (TOPS).

**Datafill sequence and implications**

The following tables must be datafilled before table SRVRS.

- SERVNAME
- SCHED

**Datafill**

The following table lists datafill for table SRVRS.

**Field descriptions (Sheet 1 of 2)**

Field	Subfield or refinement	Entry	Explanation and action
TARIFF		see subfields	Tariff key. This field is the key to the table and consists of subfields TARIFF and SERVNAME.
	TARIFF	alphanumeric (up to 32 characters)	Tariff. Enter a tariff name for a paying numbering plan area (NPA) or paying NPA-NXX. Up to 64 tariffs can be datafilled in table SRVRS.
	SERVNAME	alphanumeric (up to 16 characters)	Service rating name. Enter a service name as previously datafilled in tables SERVNAME and SERVSCRN.

**SRVRS (end)**

**Field descriptions (Sheet 2 of 2)**

Field	Subfield or refinement	Entry	Explanation and action
SCHNAME		alphanumeric (up to 17 characters)	Schedule name. Enter a schedule name for a particular tariff and service name combination as previously datafilled in table SCHED. This is used in the charging system.
RATESTEP		0 to 999	Rate step. A rate step for particular tariff and service name combination. This is used in the charging system. Up to 63 rate steps can be datafilled in table SRVRS.

**Datafill example**

The following example shows sample datafill for table SRVRS.

**MAP display example for table SRVRS**

SCHNAME RATESTEP		TARIFF
TARIFF1	FOREIGNDA	
	SCHED1	1

---

**SSETNAME**

---

**Table name**

ITOPS Rating Ratestep Calculator Schedule Set Table

**Functional description**

Table SSETNAME defines the valid schedule set names that are used by the system.

For related information, refer to table ATRIMOD.

**Datafill sequence and implications**

There is no requirement to datafill other tables prior to table SSETNAME.

The following tables must be datafilled after table SSETNAME.

- CLGSSET
- RSFOR
- RSLOC
- RSNAT

**Table size**

0 to 64 tuples

**Datafill**

The following table lists datafill for table SSETNAME.

**Field descriptions**

Field	Subfield or refinement	Entry	Explanation and action
SSETNAME		alphanumeric (1 to 16 characters)	Schedule set name. Contains a schedule set name.

## **SSETNAME** (end)

---

### **Datafill example**

The following example shows sample datafill for table SSETNAME.

#### **MAP display example for table SSETNAME**

SSETNAME
SCHSETA

---

**SSPTKINF**

---

**Table name**

NSC Trunk Groups Table

**Functional description**

Table SSPTKINF allows operating companies to assign the originating local access and transport area (LATA) number, NXX (if this is a direct trunk group from an end office), and coin traffic type to each incoming or two-way trunk group that handles number services calls. The NXX and originating LATA number are required as part of the service switching point (SSP) database query information and for the SSP Automatic Message Accounting (AMA) record. The options list, which is valid only in Canada, provides alternate carriers for trunks.

The coin traffic type is used to determine the double automatic number identification (ANI) information digits for SSP database queries and SSP AMA records.

All the incoming or two-way trunks that handle SSP number service code (NSC) calls are datafilled in table SSPTKINF. If the trunk is not datafilled in table SSPTKINF, the call is given vacant code treatment.

**Datafill sequence and implications**

The following tables must be datafilled before table SSPTKINF.

- CLLI
- TRKGRP

**Table size**

0 to 8191 tuples

**SSPTKINF** (continued)**Datafill**

The following table lists datafill for table SSPTKINF.

**Field descriptions (Sheet 1 of 2)**

Field	Subfield or refinement	Entry	Explanation and action
SSPTK		alphanumeric (1 to 16 characters)	<i>Common language location identifier</i> Enter the common language location identifier (CLLI) of trunk group handling NSC calls, incoming or two-way.
ORIGLATA		alphanumeric 3 characters (0 to 9, B, C, D, E, or F)	<i>Origination LATA number</i> Enter the originating local access and transport area (LATA) number.
DIRECTTK		see subfields	<i>Direct trunk info</i> This field consists of subfield DIRECT and refinement NXX.
	DIRECT	Y or N	<i>Direct trunk</i> If the trunk group is direct, enter Y (yes) and complete field NXX. Otherwise, enter N (no).
	NXX	numeric(3 digits)	<i>Originating office code</i> If the entry in field DIRECTTK is Y, enter the originating office code (NXX) for the trunk group if ANI is not available. Otherwise, if the entry in field DIRECTTK is N, leave this field blank.
COINTRAF		COMB, COIN, or NONCOIN	<i>Trunk traffic type</i> Enter COMB if the trunk group handles combined coin and non-coin traffic. Enter COIN if the trunk group handles coin traffic only. Enter NONCOIN if the trunk group handles non-coin traffic only.



**SSPTKINF** (end)**Field descriptions (Sheet 2 of 2)**

Field	Subfield or refinement	Entry	Explanation and action
OPTIONS		\$ or CARRIER	<i>Options list</i> This field consists of optional subfield CARRIER. This field is only valid in Canada. Enter CARRIER if alternate carriers are available. The default value is 0 (zero).
	CARRIER	numeric (0 to 9999)	<i>Carrier</i> If the entry in field OPTIONS is CARRIER, enter the number of the alternate carrier.

**Datafill example**

The following example shows sample datafill for table SSPTKINF.

**MAP display example for table SSPTKINF**

SSPTK	ORIGLATA	DIRECTTK	COINTRAF	OPTIONS
EAIN	233	Y 621	COMB	\$
ITMF1	334	N	NONCOIN	\$
TINWARD	100	N	COMB	(CARRIER 1701) \$

**Table history****NA002**

Added field OPTIONS and subfield CARRIER.

## SSRDEF

### Table name

Switch status report definition table

### Functional description

Table SSRDEF defines the switch status report (SSR) log reports generated by the Switch Status Report Generator feature. Each tuple in SSRDEF defines an SSR log report.

The initial tuple is datafilled by the system for the default log report (SSR600). Subsequent tuples may be manually datafilled to define additional SSR log reports (SSR608-SSR615).

*Note:* SSR log reports SSR601-SSR607 are reserved for future development, and are not available for use as user defined reports.

### Datafill sequence and implications

The table SSRFORM must be datafilled after table SSRDEF.

### Table size

Table SSRDEF must be between 1 and 16 tuples in length.

### Datafill

The following table lists datafill for table SSRDEF.

#### Field descriptions (Sheet 1 of 3)

Field	Subfield or refinement	Entry	Explanation and action
SSRLOGID		SSR600 to SSR615	The SSRLOGID field defines the name for each SSR log report. Log report names must be in the range of SSR600-SSR615. Log report names SSR608-SSR615 are reserved for user defined log reports.
ENBL		Y or N	The ENBL field enables or disables the specified report. When ENBL is set to N, average data for the specified report is not being accumulated and the report is not generated.
PREV		Y or N	The PREV field enables or disables the display of data from the previous reporting period for the specified report.

**SSRDEF** (continued)**Field descriptions (Sheet 2 of 3)**

Field	Subfield or refinement	Entry	Explanation and action
AVG		Y or N	The AVG field enables or disables the display of calculated average data for the specified report. This field is computed as an average of all values collected at this time of day, and day of the week over the life of the report. When AVG is set to N, average data is not being calculated for the specified report.
INTERVAL		T15, T30, AUTO, HOURLY, or DAILY	<p>The INTERVAL field defines the time interval at which the specified log report is displayed.</p> <ul style="list-style-type: none"> <li>• The T15 option will produce the report at 15 minute intervals.</li> <li>• The T30 option will produce the report at 30 minute intervals.</li> <li>• The AUTO option will produce the report once for every transfer period as defined in table OFCENG by office parameter OMXFR.</li> <li>• The HOURLY option will produce the report once every hour.</li> <li>• The DAILY option will produce the report once every day at the hour specified in the HOUR refinement.</li> </ul>

**SSRDEF** (continued)

**Field descriptions (Sheet 3 of 3)**

Field	Subfield or refinement	Entry	Explanation and action
ADDLINFO	HOUR	0 to 23	The HOUR refinement is only used when the INTERVAL field of the current tuple is set to DAILY. The HOUR refinement defines the hour at which the daily report will be produced.
		ALARM, TRK_LOW, or ORIG_CHG	<p>The ADDLINFO field defines calculations to be used in the specified report that are not based on OM data.</p> <ul style="list-style-type: none"> <li>The ALARM option includes a snapshot of the current MAPCI Alarm Status Banner in the specified report.</li> <li>The TRK_LOW option includes information on the two lowest successful trunk group rates for the reporting period in the specified report.</li> <li>The ORIG_CHG option includes the percentage change (from the last reporting period) in number of originations in the specified report.</li> </ul>

**Datafill example**

The following example shows sample datafill for table SSRDEF.

**MAP display example for table SSRDEF**

SSRLOGID	ENBL	PREV	AVG	INTERVAL	ADDLINFO
SSR600	Y	Y	Y	T15	(Alarm Trk_Low Orig_Chg)
SSR608	Y	N	Y	DAILY 8	(Alarm)
SSR609	Y	N	N	AUTO	(Trk_Low)

**Note:** The example provided is datafilled for the default SSR log report, SSR600, and for two user-defined reports, SSR608 and SSR609.

**Table history**

**BCS35**

This table was introduced in BCS35 via patch.

## SSRFORM

---

### Table name

Switch status report formula table.

### Functional description

Table SSRFORM defines the label names, verbose text, and formulas for defined reports (SSR600-SSR615) as datafilled in table SSRDEF. The datafill for SSR600, the default log report, is provided with the feature.

### Datafill sequence and implications

Table SSRDEF must be datafilled before table SSRFORM.

### Table size

Table SSRFORM must be between 0 and 256 tuples in length.

### Datafill

The following table lists datafill for table SSRFORM.

#### Field descriptions (Sheet 1 of 2)

Field	Subfield or refinement	Entry	Explanation and action
LABEL		Vector (1 to 10characters)	The LABEL field defines the title for the value to be output, as defined by the calculation in the FORMULA field.
SSRLOGID		SSR600 to SSR615	The SSRLOGID field specifies the SSR log report to which the tuple in table SSRFORM will be applicable. The report must be a report name that has been defined in table SSRDEF.

**SSRFORM** (continued)

## Field descriptions (Sheet 2 of 2)

Field	Subfield or refinement	Entry	Explanation and action
VERBOSE		Vector (40 characters maximum)	<p>The VERBOSE field provides a detailed description of each data value to be output. The verbose text is displayed only with the DISPLAY CI subcommand.</p> <p><b>Note:</b> Entries in this field must be enclosed by triple single quotes (ie, ''' ''') during datafill. The quotes are not included in the maximum character range.</p>
FORMULA		Vector (1 to 4 vectors of 1 to 60 characters)	<p>The FORMULA field defines the calculations to be used in the specified report. Vectors must consist of expressions containing the following tokens:</p> <ul style="list-style-type: none"> <li>• OM registers in the format of GROUP:REGISTER_NAME</li> <li>• Numeric constants in the range 0 to 99999</li> <li>• ( ) + - * /</li> </ul> <p><b>Note:</b> Entries in this field must be enclosed by triple single quotes (ie, ''' ''') during datafill. The quotes are not included in the maximum character range.</p>

**Datafill example**

The following example shows sample datafill for table SSRFORM.

**MAP display example for table SSRFORM**

```

LABEL      SSRLOGID  VERBOSE
-----
TOTAL_ORIG SSR600  '''Combined line and trunk originations'''
              '''OFZ:NIN + OFZ:NORIG +65536*(OFZ:NIN2 +
              OFZ:NORIG2) + CP:CCBOVFL + CP:CPLOOVF'''

DROPPED    SSR600  '''Established calls dropped by system'''
              '''CP:WINITC + CP:CINITC + PMTYP:PMTMBTCO +
              PMTYP:PMTSBTCO +SYSPERF:CINTEGFL'''

```

## **SSRFORM** (end)

---

*Note:* The sample datafill shown is for formulas in the SSR600 log report.

### **Table history** **BCS35**

This table was introduced in BCS35 via patch.



---

**STDPRTCT**

---

**Table name**

List of Standard Pretranslation Tables Table

**Functional description**

Table STDPRTCT lists the names that the operating company assigns for the standard pretranslator subtables (STDPRTCT.STDPRT). The maximum number of subtables is 4095.

**Standard pretranslator table and subtables**

In a local or combined local/toll switching unit, any incoming or two-way trunk group can have a standard pretranslator assigned. Each incoming or two-way trunk group can have a separate standard pretranslator subtable. More than one trunk groups can share the same standard pretranslator subtable.

In a toll, local, or combined local/toll switching unit, each line attribute can have a standard pretranslator subtable assigned. The line attribute can have a standard pretranslator assigned if the line class code permits origination of calls. Each line attribute can have a standard pretranslator subtable. More than one line attributes can share the same standard pretranslator subtable.

In offices with ISDN user part (ISUP) capability, ISUP trunks on test calls can automatically use standard pretranslator C7PT. Subtable STDPRTCT.STDPRT describes the test calls.

For NA009, AIN Toll-Free Service Support For Tops Mixed Trunks (AU2614) introduces three external standard pretranslator subtables. The three subtables are TFS1, TFS2, and TFS3. These subtables must contain data for toll-free traffic that originates from a traffic operator position system (TOPS) trunk group. The first-stage of pretranslation uses subtable TFS1. The second-stage of pretranslation uses subtables TFS2 and TFS3.

The pretranslator tables and subtables follow:

- STDPRTCT
- STDPRTCT.STDPRT
- STDPRTCT.AMAPRT
- TFS1
- TFS2
- TFS3

**STDPRTCT** (continued)**Datafill tips**

When the deletion of a tuple from table STDPRTCT occurs, other tuples can continue to refer to the tuple. For example, table TRKGRP can refer to a tuple deleted in table STDPRTCT.

Value REPLDIGS in field PRETRTE is not correct when you use the NSC selector in table STDPRTCT.STDPRT. Table STDPRTCT control rejects this entry when you attempt to enter data in REPLDIGS.

**List of switching unit types**

The available switching unit types appear in the following table.

**Switching unit types**

Type	Description
Local	DMS-100 local
Toll	DMS-200 toll
Local/Toll	DMS-100 local, DMS-200 toll, or DMS-100/200 combined local and toll
TOPS	DMS with Traffic Operator Position System
AOSS	DMS with Auxiliary Operator Service System
EA	DMS with Equal Access
GATEWAY	DMS-300 international

**Partitioned Table Editor feature**

In DMS offices with feature BC1459, partitioned table editor (PTE), the operating company can authorize a non-operating company user to use PTE. The user can use the PTE to edit specified tuples of table STDPRTCT. This also allows the non-operating company user to edit all the tuples of subtables STDPRTCT.STDPRT at the authorized positions of table STDPRTCT.

To access a tuple in table STDPRTCT, the user must own field EXTPRTNM. Field EXTPRTNM is the standard pretranslator name.

For example, the datafill for table DATAOWNER can have a key of STDPRT INC1. The key can index a field OWNER value of CARLING. In this event, the non-operating company user, CARLING, can access the tuples that have the key INC1. User CARLING cannot view other table STDPRTCT tuples unless table OWNER specifies as public tuples that other users own.

---

**STDPRTCT** (continued)

---

The PTE feature allows the operating company to limit edit access to a table for a specified user. The operating company can set access as denied, read only, change only, or add and delete tuples. Set the PTE access for non-operating company users as follows:

- table STDPRTCT set to change-only access
- subtables STDPRTCT.STDPRT set to add and delete tuples access

Refer to the description of table OWNER for information on the customer data change feature tables.

**STDPRTCT** (continued)

---

**Pretranslator flow**

Pretranslator flow logistics appear in the following table.

**STDPRTCT** (continued)

Flowchart showing pretranslator flow logistics

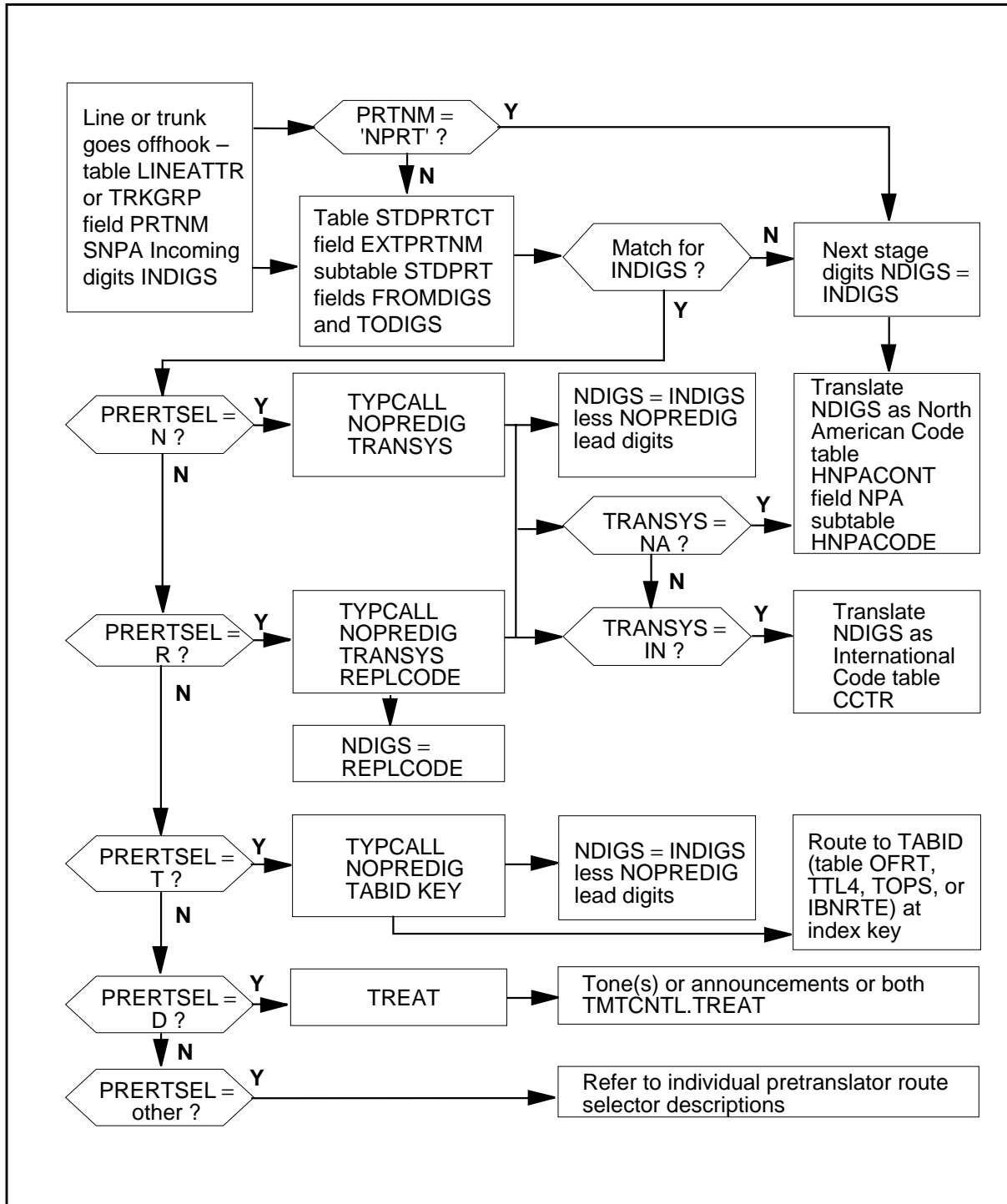

**STDPRTCT** (continued)**Table size**

The range of tuples in table STDPRTCT is 0 to 4094.

With pretranslation selectors L, N, P, or D, the maximum number of tuples in subtable STDPRTCT.STDPRT is dynamic. The digital or blocks limits of the system limit the maximum number of tuples. All other pretranslation selectors require expansion data for additional information.

Each STDPRT subtable can access 2048 items of expansion data. The current limit of tuples in table STDPRTCT is 4095. The maximum number of tuples that use expansion data can be 8,386,569 (4095 × 2048).

**Datafill**

The following table lists datafill for table STDPRTCT.

**Field descriptions**

Field	Subfield or refinement	Entry	Explanation and action
EXTPRTNM		alphanumeric (maximum of 8 characters)	External standard pretranslator subtable name. Enter the name the operating company defines to represent the standard pretranslator subtable. The ISDN ISUP trunks use standard pretranslator name C7PT on test calls in offices with ISUP capability, as described in table STDPRTCT.STDPRT. Table STDPRTCT.STDPRT does not require entry of data.
EDGE_ID		numeric	Enter a value for EDGE_ID from 0 to 63. The default value for EDGE_ID is 0. An EDGE_ID value of zero (0) means that no EDGE routing is done.  EDGE_ID is only available on EA or ET selectors. EDGE_ID is used in table STDPRTCT, subtable STDPRT so that Equal Access calls to a specific carrier can be partitioned. EDGE_ID is part of table EDGERTE.

**Datafill example**

An example of datafill for table STDPRTCT in a local (DMS-100) switching unit follows. This feature reserves memory for ten standard pretranslator subtables and provides input for six standard pretranslator subtables, HULL, COIN, OTW2, TWX2, INC1, and INC2.

**STDPRTCT** (continued)**MAP example for table STDPRTCT**

EXTPRTNM	STDPRT	AMAPRT
HULL	( 0 )	( 0 )
COIN	( 0 )	( 0 )
OWT2	( 1 )	( 0 )
TWX2	( 0 )	( 0 )
INC1	( 0 )	( 0 )
INC2	( 0 )	( 0 )

An example of datafill for table STDPRTCT in a toll (DMS-200) switching unit follows. This feature reserves memory for five standard pretranslator subtables and provides input for one standard pretranslator subtable CAMA.

EXTPRTNM	STDPRT	AMAPRT
CAMA	( 0 )	( 0 )

An example of datafill for table STDPRTCT in a DMS-200 access tandem (AT) switching unit follows. International calls translate on 1NX + XXX(X). National calls translate on OZZ + XXX(X).

EXTPRTNM	STDPRT	AMAPRT
1NXXXXX	1NXXXXX T	NP 6 OFRT 896 7 7 NONE
1NXXXX	1NXXXX T	NP 6 OFRT 895 6 6 NONE
OZZXXX	OZZXXX T	NP 6 OFRT 895 6 6 NONE
OZZXXXX	OZZXXXX T	NP 7 OFRT 896 7 7 NONE

## **STDPRTCT** (end)

---

### **Table history**

#### **NA015**

E911 Tandem-Tandem Enhancements added the new selector E911RTE to subtable STDPRTCT. This selector sends E911 transfer calls to table E911TDRT for routing.

#### **NA013**

Field EDGE\_ID added to table STDPRTCT, subtable STDPRT.

#### **NA010**

Added MAP display for national and international calls in a DMS-200 switch to show enhancements provided by the Hawaiian Telephone Phantom Carrier Identification Code feature.

#### **NA009**

The AIN Toll-Free Service Support For Tops Mixed Trunks in NA009 introduces three external standard pretranslator subtables.

#### **NA006**

The range of values for field EXTPRTNM increased. The range increased from a vector of a maximum of four characters to vector of a maximum of eight characters. The maximum number of tuples for data entry increased to 4095 for the Dial Plan Translations Enhancements feature.

#### **NA005.1A**

Added text which states that this release supports only selectors EA, N, P, and S from subtable STDPRTCT.STDPRT.



---

**STDPRTCT.AMAPRT**

---

**AMA Pretranslator Subtable**

The Automatic Message Accounting (AMA) Pretranslator (AMAPRT) subtable has the same leading digits in the index as the subtable STDPRT. The operating company enters data in this subtable to generate Bellcore-formatted AMA records for the following types of calls. These calls are separate from fixed translation designs:

- 411 directory assistance (DA)
- 555 DA
- non-DA
- DATAPATH terminating access records
- generic records

When subtable AMAPRT contains entries for these types of calls, these calls generate call codes. These calls generate call codes 009, 033, 088, 121, and 800 to 999 in the order given.

The AMA pretranslation can fill the service feature field with a value of 800 to 999 in any non-TOPS AMA record. The service feature field (SERV FIELD) is field 12. The AMA pretranslation does not affect the following types of calls:

- TOPS
- tracer (090, 092)
- overflow (037, 071, 120)
- time change (042)
- signaling irregularities (034)

The Standard Pretranslator (STDPRTCT.STDPRT) subtable is the first table that the received leading digits index. This event occurs when the originating line attribute or trunk group contains the attribute that indexes field PRTNM table STDPRTCT. Table LINEATTR contains the line attribute. Table TRKGRP contains the trunk group.

The received leading digits can index subtable AMAPRT. The digits index subtable AMAPRT if subtable STDPRT AMA pretranslation uses only the pretranslator name that table LINEATTR or TRKGRP specifies. Datafill in subtable STDPRT can cause the digits to index table STDPRTCT with the first

## STDPRTCT.AMAPRT (continued)

---

pretranslator name. In this event, AMA pretranslation uses only the first pretranslator name specified as the index to table STDPRTCT.

*Note:* If subtable AMAPRT does not contain data for the received leading digits, AMA pretranslation does not affect the generated call code.

The system can alter the received leading digits before the digits index the standard pretranslator subtable STDPRTCT.STDPRT. The system can alter the digits if the call originates from one of the following locations:

- a subscriber line with the Automatic Line (AUL)
- a subscriber line with Speed Calling (SC1 and SC2) features
- a subscriber line with Warm Line (WML) features
- a trunk with a fixed digit regeneration in field DIGSREGEN of table TRKGRP

When NPRT is the specified pretranslator, the first subtable that the received leading digits index is the Home Numbering Plan Translation (HNPACONT.HNPACODE). The serving numbering plan area (NPA) of the originator determines the HNPACONT.HNPACODE subtable. The serving NPA of the originator is field STS of table LINEATTR or field SNPA of table TRKGRP. The system does not use subtables AMAPRT and STDPRT. These tables do not affect AMA pretranslation or call code generation.

The digits for fields FROMDIGS and TODIGS in subtable AMAPRT can differ from the digits in subtable STDPRT. The operating company can enter AMA pretranslation results separately from standard pretranslation results.

Other call attributes, like equal access, contribute to the generation of call codes. The other call attributes can override the generation of call codes entered in subtable AMAPRT.

Fields OVERIDIC and OVERIDLT replace field OVERRIDE in subtable AMAPRT. The operation of these fields does not depend on the other fields. These fields specify if values determined in AMAPRT affect inter-LATA carrier (IC) and/or non-IC AMA records.

Field OVRIDIC indicates if the value in the generic call code field replaces the call code field in an IC AMA record. The values Y or N in field OVRIDIC indicate when a generic call code field value is present. If a generic call code field is not present, the default is N. This feature cannot suppress the generation of IC AMA records. If the call code that results is Y, the call code is IC or GENERIC. The IC call codes are 110, 119, 131, 132, 134, and 135.

**STDPRTCT.AMAPRT** (continued)

Field OVRIDLT contains four values. These values are OVRNONE, OVRLOCL, OVRTOLL, and OVRDALL. These values represent a category of non-IC local and toll non-IC calls. The value of the generic call code field in subtable AMAPRT affects these values. The CALLCODE field must be GENERIC or NONE before the OVRIDLT field can accept data.

**Datafill**

Datafill for table STDPRTCT.AMAPRT appears in the following table.

**Field descriptions (Sheet 1 of 3)**

Field	Subfield or refinement	Entry	Explanation and action
FROMDIGS		numeric (vector of a maximum of 18 digits)	<i>From digits.</i> Enter the digit or digits to translate.  If the entry represents a block of numbers that follow in order, enter the first number in the block.
TODIGS		numeric (vector of a maximum of 18 digits)	<i>To digits.</i> If field FROMDIGS represents a block of numbers that follow in order, enter the last number in the block.  For other conditions, the entry is equal to the entry in field FROMDIGS.
AMARSLT		see subfields	<i>AMA result.</i> This field contains subfields CALLCODE and SFPRSNT.  Enter GENERIC for field CALLCODE, and enter subfields GENRCVAL, OVRIDIC, and OVRIDLT.  Enter AMAXLAID and complete subfield AMAXLAID.  If SFPRSNT equals Y, the refinement subfield is SFEATVAL.

**STDPRTCT.AMAPRT** (continued)

## Field descriptions (Sheet 2 of 3)

Field	Subfield or refinement	Entry	Explanation and action
	CALLCODE	AMAXLAID DA411 DA555 DATAPATH GENERIC NONDA555 or NONE	<p><i>Call code.</i> Enter AMAXLAID to generate an AMA record identified in a table AMAXLAID entry. Enter data in subfield AMAXLAID.</p> <p>Enter DA411 to generate an AMA record that call code 009 identifies for a local DA call.</p> <p>Enter DA555 to generate an AMA record that call code 033 identifies for a 555 DA call.</p> <p>Enter DATAPATH to generate an AMA record that call code 121 identifies for an InterLATA DATAPATH call.</p> <p>Enter GENERIC to generate call codes 800 to 999.</p> <p>Enter NONDA555 to generate an AMA record that call code 088 identifies for a call to 555-XXXX other than 555-1212.</p> <p>Enter NONE to retain the call code generated.</p>
	AMAXLAID	alphanumeric (one to eight characters)	<p><i>Automatic message accounting translation ID.</i> If field CALLCODE is AMAXLAID and flexible AMA translation is a requirement, enter a one to eight character AMA translation identifier. Table AMAXLAID must contain this entry before subtable AMAPRT can use this entry.</p>
	GENRCVAL	800 to 999	<p><i>Generic values.</i> If the entry in field CALLCODE is the value GENERIC, enter one value in the range 800 to 999.</p>
	OVRIDIC	Y or N	<p><i>Override IC AMA records.</i> If the field does not have a generic call code set, the field defaults to N. If set to Y, the call code that results is IC or GENERIC. The IC call codes are 110, 119, 131, 132, 134, and 135.</p>
	OVRIDLT	OVRNONE OVRLOCL OVRTOLL OVRDALL	<p><i>Override non-IC AMA records (local/toll).</i> A GENERIC or NONE setting can generate local or toll AMA types.</p> <p>The OVRIDLT field only recognizes a GENERIC or NONE call code setting.</p>

**STDPRTCT.AMAPRT** (continued)**Field descriptions (Sheet 3 of 3)**

Field	Subfield or refinement	Entry	Explanation and action
	SFPRSNT	Y or N	<p><i>Service feature present.</i> Enter Y if the value entered in the SFEATVAL field must replace the current Service Feature field.</p> <p>Enter N if the current Service Feature field value must not change.</p>
	SFEATVAL	800 to 999	<p><i>Service feature value.</i> If the entry in field SFPRSNT is Y, enter a value from 800 to 999. This value replaces the current service feature value generated for the call if the call is non-TOPS.</p> <p>If the entry in field SFPRSNT is N, leave this field blank.</p>

**Datafill example**

The first datafill entry generates call code 088 if the received leading digits are 555-1234. The pretranslator name is PRT1. Table LINEATTR or table TRKGRP provide the pretranslator name. The service feature value does not change. The received leading digits are 555-1235. The pretranslator name is PRT1. Table LINEATTR or table TRKGRP provide the pretranslator name. The system replaces the service feature value with value 800 in the AMA record.

The third datafill entry generates call code 801 if the received leading digits are 622-xxxx and the pretranslator name is PRT1. The number 622-xxxx is any number that starts with 622. Tables LINEATTR or TRKGRP provide the pretranslator name. This call code overrides any other non-TOPS call code that the AMA record generates. The service feature value does not change.

The fourth datafill entry generates call code 901 if the received leading digits are 620-xxxx and the pretranslator name is PRT1. Number 620-xxxx is any number that starts with 620. Tables LINEATTR or TRKGRP provide the pretranslator number. The current call code hierarchy determines the call code generated. The service feature value does not change. The generic call code field value can replace the call code field in an IC AMA record. The entries Y or N in field OVRIDIC indicate if this condition occurs. This event can occur when a generic call code field value is present as the fifth entry. If the field is Y, the call code that results can be 110, 119, 131, 132, 134, or 135. Field OVRIDLTL with four values is the sixth entry. These values represent a category of non-IC local and toll non-IC calls. The value of the generic call

**STDPRTCT.AMAPRT (end)**

code field in subtable AMAPRT affects these calls. Field OVRIDLT cannot accept data unless field CALLCODE equals GENERIC or NONE. The operation of the OVRIDIC and OVRIDLC fields does not depend on each other.

The fifth datafill entry generates call code 899 if the received leading digits are 623-xxxx and the pretranslator name is PRT1. The number 623-xxxx is any number that starts with 623. Table LINEATTR or table TRKGRP provide the pretranslator name. The current call code hierarchy determines the call code that the system generates. The value 999 in the AMA record replaces the service feature value.

The sixth datafill entry does not affect the call code that the system generates if the received leading digits are 787-xxxx. The entry does not affect the call code if the leading digits are 787-xxxx and the pretranslator name is PRT1. Table LINEATTR or table TRKGRP provide the pretranslator name. The value 850 in the AMA record replaces the service feature value that the system generates for the call.

**Datafill example**

Sample datafill for table STDPRTCT.AMAPRT appears in the following example.

**MAP example for table STDPRTCT.AMAPRT**

FROMDIGS	TODIGS	AMARSLT
5551234	5551234	NONDA555 N
5551235	5551235	NONDA555 Y 800
622	622	GENERIC 801 Y OVRTOLL N
620	620	GENERIC 901 N OVRTOLL N
623	623	GENERIC 899 N OVRTOLL Y 999
787	787	NONE OVRTOLL Y 850
782	782	AMAXLAID GENERIC1
787	787	AMAXLAID GENERIC2

---

**STDPRTCT.STDPRT**

---

**Table name**

Standard Pretranslator Subtable

**Functional description**

Subtable STDPRTCT.STDPRT is the first table indexed by the received leading digits, provided that table LINEATTR or table TRKGRP specifies a pretranslator name (field PRTNM) other than NPRT (no pretranslator).

*Note:* The received leading digits can be altered before indexing into the standard pretranslator when the call originates from a subscriber line with the Automatic Line (AUL), Speed Calling (SC1 and SC2), or Warm Line (WML) feature, or from a trunk with fixed-digit regeneration (field DIGREGEN of table TRKGRP).

When pretranslator name is NPRT, the first table to be indexed by the received leading digits is subtable HNPACONT.HNPACODE selected by the originator's serving numbering plan area (NPA) (field STS of table LINEATTR or field SNPA of table TRKGRP).

The pretranslator subtable applicable to the originator is selected by the pretranslator name, and the next stage of translation is determined from the record with a specified digit range (fields FROMDIGS and TODIGS) that matches the received leading digits. The pretranslator route selector (field PRERTSEL) defines the next stage of translation and the combination of other fields.

When no match is found for the received leading digits, translation proceeds to subtable HNPACONT.HNPACODE, selected by the originator's serving NPA (field STS of table LINEATTR or field SNPA of table TRKGRP).

When a major change is made to a standard pretranslator table, a new standard pretranslator table is set up, and references in tables LINEATTR or TRKGRP are changed to point to the new standard pretranslator table.

For related information, refer to table STDPRTCT.

**Subtable defaults and general field information**

When the subtable is initialized, the digits 0 to 9 are automatically set to the following values:

- the selector equal to N
- translation system equal to NA (national translations)

## **STDPRTCT.STDPRT** (continued)

---

- type of call equal to NP (no prefix)
- number of prefix digits equal to 0

### **FROMDIGS to TODIGS range**

A requested change can overwrite neighboring FROMDIGS to TODIGS ranges. This overwriting results in the neighboring tuple ranges being included in the range requested by the change. This can cause the data from the previously neighboring tuple to be lost. Care must be taken before changing the range of the FROMDIGS to TODIGS tuple.

The FROMDIGS and TODIGS range of a pretranslation must be greater than or equal to the FROMDIGS and TODIGS range of a recursive pretranslation. Matching the screened digits of a recursive stage of pretranslation to the screened digits of the previous stage of pretranslation, is particularly important for digits reported one at a time (digit collection selector RPT in table DIGCOL).

### **DMSMON DBLOCKS command**

The DMS monitoring system (DMSMON) command DBLOCKS provides the number of digit blocks being used, the number of digit blocks allocated, the percent used, and the percent available for each of the following tables:

- CLSVSCRC.CLSVSCR
- CODEBLK
- HNPACONT.HNPACODE
- IBNXLA
- LATAXLA
- SPLDNID
- STDPRTCT.STDPRT
- E911TDRT

The following is a brief functional description of the pretranslator selectors and their associated fields. A more detailed description is given in the “Field description” section.

### **Pretranslator route selector: D**

Pretranslator route selector D is used if a call is to proceed directly to specified treatment. For further information, refer to subtable STDPRTCT.STDPRT selector D.



---

**STDPRTCT.STDPRT** (continued)

---

**Pretranslator route selector: EA**

Pretranslator route selector EA is used in a local switching unit with the following equal access (EA) options:

*Equal access translation type N* is used if a call is to proceed to carrier through a specified EA route with no intermediary digit translations.

*Equal access translation type P* with specified EA route is used if a call is to proceed to second-stage pretranslator for further digit translations. If the result of the digit translations is not a treatment, the call proceeds to the last EA route specified in either pretranslator stage instead of the route prescribed by digit translations.

*Equal access translation type P with no specified EA route* is used if a call is to proceed to specified pretranslator for further digit translations and then proceed as determined by the digit translations.

*Equal access translation type T with specified EA route* is used if a call is to proceed to specified national (which is subtable HNPACONT.HNPACODE) or international (table CCTR) digit translations. If the result of the digit translations is not a treatment, the call proceeds to the carrier through the specified EA route.

*Equal access translation type T with no specified EA route* is used if call proceeds to specified national (subtable HNPACONT.HNPACODE) or international (table CCTR) digit translations and then proceed as specified by the digit translations.

For further information, refer to subtable STDPRTCT.STDPRT selector EA.

**Equal Access for DMS-100 Wireless**

For EA on the DMS-100 Wireless switch, datafill separate pretranslators for wireless and wireline end users. This procedure ensures that EA calls dialed by wireless end users route over integrated service link (ISL) trunks. EA calls dialed by wireline end users route over the intertoll (IT) or access to carrier (ATC) trunks to the access tandem (AT) or interexchange carrier (IEC).

**Pretranslator route selector: ET**

Pretranslator route selector ET is used on feature group D (FGD) calls in a special equal access end office (EAEO) called an EA tandem switching point (EASP) to tandem equal access calls between an existing EAEO and an access tandem (AT).

For further information, refer to subtable STDPRTCT.STDPRT selector ET.

## **STDPRTCT.STDPRT** (continued)

---

### **Pretranslator route selector: E911**

Pretranslator route selector E911 is used in offices with the Enhanced 911 Emergency Service Feature for 911 calls incoming on message and FX trunks (non-E911 trunks) to specify the following:

- an emergency service number (ESN), index into table E911ESN, to route the call to the applicable public safety answering point (PSAP) directory number
- an emergency service central office (ESCO) number for use in the substitute automatic number identification (ANI) forwarded to the PSAP by the E911 tandem

The pretranslator selector E911 cannot be used for calls originated by lines, coin, or noncoin. In case of coin lines, the coin is not returned as the called digits 911 are replaced by the PSAP directory number.

For further information, refer to subtable STDPRTCT.STDPRT selector E911.

### **Pretranslator route selector: E911RTE**

Pretranslator route selector E911RTE is used in super dual tandem-tandem networks to transfer E911 calls through table E911TDRT. The call field type can be datafilled with the same values as for the T selector: DD, OA, NP, and NL.

Datafilling selector E911RTE allows routing of E911 transferred calls based on the tandem prefix value (TDMPRFX) and the called number in table E911TDRT.

See subtable STDPRTCT.STDPRT selector E911RTE for more information.

### **Pretranslator route selector: F**

Pretranslator route selector F is used if second dial tone or recycling for more digits is required.

If selector F is used with 950 dialing and 950 type calls, digit reception is delayed 10 to 15 s during the processing of the call.

For further information, refer to subtable STDPRTCT.STDPRT selector F.

### **Pretranslator route selector: FGB**

Pretranslator route selector FGB is used to identify a call as a feature group B (FGB) call (950-WXXX dialing) in the translation stage of the call. This is necessary to distinguish FGB calls terminating on an intertoll trunk from other

---

**STDPRTCT.STDPRT** (continued)

---

call types. Selector FGB must be used in the end office to allow Local Automatic Message Accounting (LAMA) billing on tandem routed FGB calls.

For further information, refer to subtable STDPRTCT.STDPRT selector FGB.

**Pretranslator route selector: FGDCL**

Pretranslator route selector FGDCL is used at an access tandem (AT) to handle calls incoming from an equal access end office (EAEO) using FGD multifrequency (MF) signaling requiring ANI and called number collection and translation.

The translation result FGDCL, of the first stage digits (OZZXXX), triggers the ANI and called-number collection. After ANI and called-number collection, the route for the call is determined by translating the called number.

Selector FGDCL is only supported on IT or SC trunk group types.

For further information, refer to subtable STDPRTCT.STDPRT selector FGDCL.

**Pretranslator route selector: ID (Meridian SuperNode)**

Pretranslator route selector ID is used in Meridian SuperNode switching unit to translate feature group D (FGD) ANI ID digits and the 1NX (routing digits appearing in the first digit stream of an international call, where N = 1 to 9 and X = 0 to 9) code in the first digit stream of an FGD international call.

For further information, refer to subtable STDPRTCT.STDPRT selector ID.

**Pretranslator route selector: L**

Pretranslator route selector L is used if seven digits are received from an incoming trunk group and direct access to the directory number translation is required.

Do not use selector L with trunk group type IT.

For further information, refer to subtable STDPRTCT.STDPRT selector L.

**Pretranslator route selector: N**

Pretranslator route selector N is used if a call is to proceed to specified national (subtable HNPACONT.HNPACODE) or international (table CCTR) digit translations.

For further information, refer to subtable STDPRTCT.STDPRT selector N.

## **STDPRTCT.STDPRT** (continued)

---

### **Pretranslator route selector: NSC**

Pretranslator route selector NSC is used in an AT/SSP to detect number service code (NSC) calls from an EAEO using EA signaling. The EAEO outpulses the sequence: KP + 0ZZ + XXX + ST with a special code XXX, to indicate the call is an NSC call.

For further information, refer to subtable STDPRTCT.STDPRT selector NSC.

### **Pretranslator route selector: P**

Pretranslator route selector P is used if operator intervention is required on a call that is to proceed to the specified national (subtable HNPACONT.HNPACODE) or international (table CCTR) digit translations and operator intervention is not automatically provided for by the DMS software.

For further information, refer to subtable STDPRTCT.STDPRT selector P.

### **Pretranslator route selector: R**

Pretranslator route selector R is used if a call proceeds to specified national (subtable HNPACONT.HNPACODE) or international (table CCTR) digit translations after replacing all received digits with the specified digits.

For further information, refer to subtable STDPRTCT.STDPRT selector R.

### **Pretranslator route selector: S**

Pretranslator route selector S is used if a call proceeds directly to a common language location identifier (CLLI).

For further information, refer to subtable STDPRTCT.STDPRT selector S.

### **Pretranslator route selector: SFMT**

DMS packet handler type: SFMT is used if call is to proceed to specified pretranslator for digit translations through a DMS packet handler switching system.

For further information, refer to subtable STDPRTCT.STDPRT selector SFMT.

### **Pretranslator route selector: SSP**

Pretranslator route selector SSP is used to indicate if Service Switching Point (SSP) processing is required for the EA (FGD signaling) call.

For further information, refer to subtable STDPRTCT.STDPRT selector SSP.

---

**STDPRTCT.STDPRT** (continued)

---

**Pretranslator route selector: T**

Pretranslator route selector T is used if a call is to proceed directly to a test line or office route table.

For further information, refer to subtable STDPRTCT.STDPRT selector T.

**Pretranslator route selector: V**

Pretranslator route selector V is used if the number of digits expected on an incoming trunk group is variable, and both the minimum and maximum number of digits are fixed.

For further information, refer to subtable STDPRTCT.STDPRT selector V.

**Pretranslator route selector: X**

Selector X is superseded by a new route selector V. When the selector is datafilled as X the output is the selector V. Selector V duplicates the functions of both selector X and old V formats. The physical data structure has been modified so that any tuples using the X format are output in the V format.

**Pretranslator route selector: Z**

Pretranslator route selector Z is used if the number of digits expected on an incoming trunk group is variable and the minimum number of digits received is fixed, but the maximum number of digits is variable.

For further information, refer to subtable STDPRTCT.STDPRT selector Z.

**Selectors**

The following pretranslator route selectors are associated with table STDPRTCT.STDPRT. For the description and the field datafill for each selector, refer to the appropriate subtable of table STDPRTCT.STDPRT. For example, for the description of selector D, refer to subtable STDPRTCT.STDPRT selector D.

- D
- EA
- ET
- E911
- E911RTE
- F
- FGB
- FGDCL

## **STDPRTCT.STDPRT** (continued)

---

- ID
- L
- N
- NSC
- P
- R
- S
- SFMT
- SSP
- T
- V
- X (see table STDPRTCT.STDPRT selector V)
- Z

### **Datafill sequence and implications**

There is no requirement to datafill other tables prior to table STDPRTCT.STDPRT.

### **Table size**

The total number of tuples in subtables STDPRTCT.STDPRT can vary. Each subtable has one digilator, and the number of tuples that a digilator can have varies according to the way the digilator tree is set up. This applies to tuples with selectors D, N, L, and P. All other selectors use expansion data.

Each STDPRT subtable has the capability to access 2048 items of expansion data. With the current limit of 4095 tuples in table STDPRTCT, this equates to a maximum number of tuples using expansion data of 8,386,569 ( $4095 \times 2048$ ).

### **Datafill**

Tables listing datafill for table STDPRTCT.STDPRT are provided in the sections for each selector.

### **Datafill example**

Datafill examples for table STDPRTCT.STDPRT are listed below.

**STDPRTCT.STDPRT** (continued)**Example 1: Second dial tone for POTS lines (local/toll)**

An example of datafill in a local/toll switching unit for the two pretranslator tables for regular lines that require second dial tone after receipt of digits 137 is shown below.

The first pretranslator (PRT1) routes all calls whose first three digits are 137 to the second pretranslator PRT2.

All calls with first three digits other than 137 are routed to the table HNPACODE for digit translation.

The second pretranslator (PRT2) deletes the digits 137, sets the type of call to DD and routes translation to table HNPACODE for translations of the remaining digits.

**Note:** If selector F is used with 950 dialing and 950 type calls, digit reception is delayed 10 to 15 s during the processing of the call.

**MAP display example for table STDPRTCT.STDPRT**

FROMDIGS	TODIGS	PRETRTE
137	137	NORM PRT2
0	F 3 9	N DD 3 NA

**Example 2: Second dial tone for incoming trunk group (IBN)**

An example of datafill for the two pretranslator tables for an IBN trunk group that requires second dial tone after receipt of digits 144 is shown below.

The first pretranslator (IBN1) routes all calls whose first three digits are 144, to the second pretranslator (IBN2).

All calls with first three digits other than 144 are routed to IBN translation table (IBNXLA) for digit translation.

**STDPRTCT.STDPRT** (continued)

The second pretranslator (IBN2) deletes the digits 144 and routes all calls to a trunk group that has a code of BRAM in the table CLLI.

*Note:* If selector F is used with 950 dialing and 950 type calls, digit reception is delayed 10 to 15 s during the processing of the call.

**MAP display example for table STDPRTCT.STDPRT**

FROMDIGS	TODIGS	PRETRTE
144	144	
0	F 3	NORM IBN2
S NP 3	9	
	BRAM	7 15 NONE

**Example 3: Typical datafill for lines (local)**

An example of datafill for a standard pretranslator subtable designated HULL in a local switching unit is shown below.

This subtable is assigned to the line attributes for individual flat and message rate lines, individual private branch exchange (PBX) lines, and two-party and multiparty lines.

Upon receipt of digit 0, translation waits for additional digits.

If no further digits are received (0 call), routing is through the position specified in field ZEROMPOS in the line attribute table.



**STDPRTCT.STDPRT** (continued)

Datafill is supplied for the following digits or codes:

(Sheet 1 of 2)

Digits or codes	Description
000 to 010	These codes are routed to vacant code treatment.
011	<p>These digits are the prefix digits for overseas direct dial calls. The digits 01 are deleted (number of prefix digits set to 2). Digits are outpulsed to the toll switch that the local switch homes to.</p> <p>Format KP +1 + CC+ NN+ and appropriate ST signal are used for outpulsing.</p> <p>Country code translation is performed in the toll switch.</p>
012 to 019	<p>Digits 01 are the prefix digits for overseas operator assisted calls. This entry is only used if local switch homes on a TOPS or TSPS and switch is arranged for operator assisted overseas calls.</p> <p>The digit 0 is deleted (number of prefix digits set to 1).</p> <p>Digits outpulsed, format for outpulsing, and country code translation are the same as code 011.</p>
02 to 09	<p>Digit 0 is for prefix digit for operator assisted calls. This entry is only required for switching units arranged for 0+ dialing.</p> <p>The number of prefix digits is set to 1 so that the prefix digit is removed from digit translation.</p> <p>The type of call is set to OA (operator assisted) so that all calls with prefix digit 0 are routed to the correct class of service screening table and receive the correct prefix treatment.</p> <p>The translation routes to national translation (home NPA code table) for digit analysis.</p>
1	<p>This digit is the prefix digit (1+) for toll station-to- station calls.</p> <p>Upon receipt of the prefix digit translation routes to national translation (table HNPACODE) for digit analysis.</p>

**STDPRTCT.STDPRT** (continued)

(Sheet 2 of 2)

Digits or codes	Description
	<p>The number of prefix digits is set to 1 so that the prefix digit is removed from digit translation. Type of call is set to DD (direct dial) so that all calls with prefix digit 1 are recorded on tape for billing purposes and translation is routed to the correct class of service screening table and receive the correct prefix treatment.</p> <p>If dialing of prefix digit (1+) is optional see prefix treatment table for updating type of call for toll station-to-station calls from NP (no prefix) to DD.</p>
611	<p>Calls to the repair service desk (code 611) are to terminate on line with directory number 7252350. Translation routes to national translation (table HNPACODE) with replacement code 7252350 for digit analysis.</p>
7252350	<p>Subscribers are not permitted to dial the directory number 7252350 that is assigned to the repair service code 611, therefore this number is routed to unassigned directory number treatment (UNDN) in the office treatment table.</p>

All codes with first digit equal to 2, 3, 4, 5, 8, or 9, upon receipt of first digit, routes to national translations (table HNPACODE) with type of call set to NP and number of prefix digits set to 0.

All codes with first digit equal to 6 (excluding 611), upon receipt of the following two or three digits, routes to national translation (table HNPACODE) with type of call set to NP and number of prefix digits set to 0. This includes

- 60
- 62 to 69
- 610
- 612 to 619

All codes with first digit equal to 7 (excluding 7252350), upon receipt of the following two to seven digits, routes to national translation (table

**STDPRTCT.STDPRT** (continued)

HNPACODE) with type of call set to NP and number of prefix digits set to 0. This includes

- 70 to 71 and 73 to 79
- 720 to 724 and 726 to 729
- 7250 to 7251 and 7253 to 7259
- 72520 to 72522 and 72524 to 72529
- 725230 to 725234 and 725236 to 725239
- 7252351 to 725359

Calls to NNX codes 455 and 456 in NPA 819 are local calls to subscribers on this switching unit.

All calls by subscribers to these switching units through the toll switch by dialing 819 to 455 or 456xxxx are routed to misplaced CAMA treatment.

It is assumed that the operating company policy is to perform all six-digit screening in the toll switching unit. See standard pretranslator subtable CAMA for screening of NNX codes in NPA 819 that are local calls to this switching unit.

**MAP display example for table STDPRTCT.STDPRT**

FROMDIGS	TODIGS	PRETRTE
000	010	D VACT
011	011	
S DD 2	OTWAON230T3	11 14 NONE
012	019	
S OA 1	OTWAON230T3	11 14 NONE
02	09	N OA 1 NA
1	1	N DD 1 NA
611	611	
	R NP 0 NA	7252350 NONE
7252350	7252350	
		D UNDN

**STDPRTCT.STDPRT** (continued)

**Example 4: Typical datafill input for dial-tone-first coin lines (local)**

An example of datafill for a standard pretranslator subtable designated COIN in a local (DMS-100) switching unit is shown below.

This subtable is assigned to the line attribute for dial-tone-first coin lines.

All codes with the first digit equal to 2 to 9 are routed the same as those defined for standard pretranslator subtable HULL.

Datafill is provided for digits 0 and 1 as follows:

0	<p>Coin lines are not permitted to dial special toll calls (0+). Entering digit 0 routes coin line to the operator (0-) trunk group, with type of call equal to operator assisted (OA) and minimum and maximum digits equal to 1.</p> <p>If coin lines are permitted to dial special toll calls (0+), datafill input data for digit 0 as shown for digit 0 (zero) in standard pretranslator subtable HULL and specify route for operator (0-) call in line attribute.</p>
1	<p>Coin lines are not permitted to dial toll station to station calls (1+). Entering digit 1 routes coin line to the denied toll treatment (TDND) in office treatment table.</p> <p>If coin lines are permitted to dial toll station-to-station calls, datafill input data for digit 1 as shown for digit 1 in standard pretranslator subtable HULL.</p>

**MAP display example for table STDPRTCT.STDPRT**

FROMDIGS	TODIGS	PRETRTE
0	0	
S OA 0	OTWAON231BB6	1 1 NONE
1	1	D TDND
611	611	
	R NP 0 NA	7252350 NONE
7252350	7252350	D UNDN

**STDPRTCT.STDPRT** (continued)**Example 5: Typical datafill for OUTWATS lines (local)**

An example of datafill for a standard pretranslator subtable designated OTW2 in a local (DMS-100) switching unit is shown below.

This subtable is assigned to the line attribute for outward wide area telephone service (OUTWATS) lines.

Datafill is provided for digits 0 to 9 as follows:

0	OUTWATS lines are not permitted to dial special toll calls (0+). Entering digit 0 routes lines to OUTWATS assistance trunk group with type of call equal to operator assisted (OA) and minimum and maximum number of digits equal to 1.
1	OUTWATS lines are not required to dial the prefix digit (1+) 1. Entering digit 1 routes translation to misplaced CAMA treatments (MSCA) in the office treatment table.
2 to 9	All codes with first digit equal to 2 to 9 are routed the same as those defined for standard pretranslator subtable HULL. Datafill is only provided for digits 2 to 9 to change type of call from NP (no prefix) to DD (direct dial), so that calls from OUTWATS lines are recorded on tape for billing purposes.

**MAP display example for table STDPRTCT.STDPRT**

FROMDIGS	TODIGS	PRETRTE
0	0	
S OA 0	OTWAON231BB3	1 1 NONE
1	1	D MSCA
2	9	N DD 0 NA
611	611	
	R NP 0 NA	7252350 NONE
7252350	7252350	D UNDN

**STDPRTCT.STDPRT** (continued)

**Example 6: Typical datafill for TWX lines (local)**

An example of datafill for a standard pretranslator subtable designated TWX2 in a local (DMS-100) switching unit is shown below.

This subtable is assigned to the line attribute for TWX lines.

Datafill is provided for digit 0 to 9 as follows:

0 to 1	All codes with the first digits 0 or 1 are routed to vacant code treatment (VACT) in office treatment table.
2 to 9	All codes with the first digit equal to 2 to 9, upon receipt of first digit, route to national translation (table HNPACODE) with type of call and number of prefix digits set to DD (direct dial) and 0 respectively

**MAP display example for table STDPRTCT.STDPRT**

FROMDIGS	TODIGS	PRETRTE
0	1	D VACT
2	9	N DD 0 NA

**Example 7: Incoming trunk group receiving five digits and prefixing digits 72 (local)**

An example of datafill for a standard pretranslator subtable designated INC1 in a local (DMS-100) switching unit is shown below.

This subtable can only be assigned to incoming and two-way trunks with five incoming digits and with the digits 72 prefixed from the trunk group.

**STDPRTCT.STDPRT** (continued)

Datafill is supplied for the following digits and codes:

725	All calls with code 725 terminate on the line with station number xxxx in terminating office code 725.
727	All calls with code 727 tandem through the trunk group (OTWAON237270) and outpulse seven digits for termination to the line with station number xxxx in switching unit with NNX code 727.
728	All calls with code 728 route to the office route table for deletion of digits 72, and then tandem through the trunk group (OTWAON237280), and outpulse five digits for termination to line with station number xxxx in switching unit with NNX code 728.
0 to 6, 8 to 9, 70 to 71, 73 to 79, 720 to 724, 726, 729	All calls, upon receipt of digit or digits specified, route to the vacant code treatment in treatment table.

**MAP display example for table STDPRTCT.STDPRT**

FROMDIGS	TODIGS	PRETRTE
0	9	D VACT
725	725	L NP 0 613 725
727	727	S NP 0 OTWAON237270 7 7 NONE
728	728	T NP 0 OFR3 2 7 7 NONE

**Example 8: Incoming trunk group receiving five or six digits (local)**

An example of datafill for a standard pretranslator subtable designated INC2 in a local (DMS-100) switching unit is shown below.

**STDPRTCT.STDPRT** (continued)

This subtable can be assigned to incoming and two-way trunk groups that receive a variable number of digits (five or six) and are arranged to terminate to lines with the station number assigned to NNX code 725 and tandem calls to the lines with station numbers assigned to NNX codes 233 and 239.

3	If the digits received are 3-xxxx, the digits 23 are prefixed and translation routes to national translation for digit analysis of number 233-xxxx. If digits received are 39-xxxx, the digit 2 is prefixed and translation routes to national translation for digit analysis of number 239-xxxx.
5	If the digits received are 5-xxxx, the digits 72 are prefixed and translation routes to national translation for digit translation of numbers 725-xxxx.
0 to 2, 4, 6 to 9	On receipt of the first digit, translation routes to the vacant code treatment in the office treatment table.

**MAP display example for table STDPRTCT.STDPRT**

FROMDIGS	TODIGS	PRETRTE
0	2	D VACT
3	3	
V 5 NP 0 N NA	23 6 NP 0 N NA	2
4	4	D VACT
5	5	
V 5 NP 0 N NA	72 5 NP 0 N NA	72
6	9	D VACT

**Example 9: Incoming CAMA trunk group (local/toll)**

An example of datafill for a standard pretranslator subtable designated CAMA in a TOLL or a combined local/toll switching unit that is arranged for direct dial overseas translation is shown below.

This subtable is assigned to incoming CAMA trunk groups.



**STDPRTCT.STDPRT** (continued)

Datafill is provided for the following digits and codes:

(Sheet 1 of 2)

Digits or codes	Description
0	If the first digit received is 0, translation routes to an unauthorized CAMA treatment in the incoming CAMA treatment table. If the switching unit has no incoming CAMA treatment table the office treatment table is selected.
1	This entry is required if a direct dial or operator-assisted overseas call originates from a common control switching unit, if incoming digits are in the format KP + 1 + CC + NN +, and the appropriate ST signal.
10	This entry is required if the following two entries, digits 11 and 12 to 19, are used for overseas dialing.
11	This entry is required if a direct dial overseas call originates from a dial pulse switching unit, if incoming digits are in the format KP + 11+ CC + NN +, and the appropriate ST signal.
12 to 9	This entry is required if an operator assisted overseas call originates from a dial pulse switching unit, if incoming digits are in the format KP + 1 + CC + NN + and the appropriate ST signal.
819455, 819456	<p>These codes in NPA 819 are local calls for subscribers and in the Hull-Ottawa region.</p> <p>Dialing of these codes and switching through the toll switch is not permitted, and such calls are routed to the misdirected CAMA call treatment in the incoming CAMA treatment table.</p> <p>If the switching unit has no incoming CAMA treatment table, the office treatment table is selected.</p>

**STDPRTCT.STDPRT** (continued)

(Sheet 2 of 2)

Digits or codes	Description
2 to 7, 9	All codes with the digits equal to 2 to 7 or 9, on and 9 receipt of the first digit, translation routes to digit, translation routes to national translation (table HNPACODE) for digit analysis. Type of call is set to direct dial (DD) so that correct class-of-service screening and prefix treatment is selected; details of the call are also recorded.
8	All codes with the first digit equal to 8 (excluding 819455 and 819456), on receipt of the following 2 to 6 digits, route to national translations (table HNPACODE) with type of call and number of prefix digits set to DD (direct dial) and 0 respectively. <ul style="list-style-type: none"><li>• 80</li><li>• 82 to 89</li><li>• 810 to 818</li><li>• 8190 to 8193</li><li>• 8195 to 8199</li><li>• 8140 to 81944</li><li>• 81946 to 81944</li><li>• 819450 to 819454</li><li>• 819457 to 819459</li></ul>

**STDPRTCT.STDPRT** (continued)**MAP display example for table STDPRTCT.STDPRT**

FROMDIGS	TODIGS	PRETRTE
0	0	D UNCA
10	10	D UNCA
11	11	N DD 2 IN
12	19	N OA 1 IN
2	9	N DD 0 NA
819455	819456	D MSCA

**Example 10: Incoming operator and verification trunk group (local)**

An example of datafill for a standard pretranslator TCVR that is assigned to an incoming operator trunk group that is combined toll completing and verification is shown below. This trunk group must be arranged for variable digits. Minimum and maximum digits are set to 5 and 7 respectively.

Datafill is provided as follows:

00	These are the prefix digits for verification. The number of prefix digits is set to two. For deletion of these digits from translation, type of call OA, flags the type of call to be verified. The additional five digits route to the associated directory number through trunk group VER90 and the metallic test access.
5	Calls with the first digit equal to 5 toll completes the line number xxxx in office code 725 through table HNPACODE.
1 to 4, 6 to 9	Calls with the first digit equal to 1 to 4, or 6 to 9, route to the vacant code.

**STDPRTCT.STDPRT** (continued)

**MAP display example for table STDPRTCT.STDPRT**

FROMDIGS	TODIGS	PRETRTE
00	00	
V 7 OA 2 N NA	72 7 OA 2 N NA	72
1	4	D VACT
5	5	
V 5 NP 0 N NA	72 5 NP 0 N NA	72
6	9	D VACT

**Example 11: Lines in a switching unit with five digit dialing**

An example of datafill for a standard pretranslator FRMR that is assigned to lines in a switching unit arranged for five-digit dialing and no direct distance dialing is shown below.

Datafill is provided as follows:

0	This is the trunk group that a subscriber is connected to upon dialing operator (0-).
1	All calls with the first digit equal to 1 are routed to the national translations for translation of 11X service codes.
5	Terminating to lines within the switching unit, these lines are assigned to office code 725.
6	Outgoing E.A.S. to a switching unit that lines with office code 236 are terminated to.
2, 3, 4, 7, 8, 9	Route to the vacant code.

**STDPRTCT.STDPRT** (continued)**MAP display example for table STDPRTCT.STDPRT**

FROMDIGS	TODIGS	PRETRTE
0	0	
S OA 0	OTWAON231BB6	1 1 NONE
1	1	N NP 0 NA
2	4	D VACT
5	5	
V 5 NP 0 N NA	72 5 NP 0 N NA	72
6	6	
S NP 0	OTWAON2360	5 5 NONE
7	9	D VACT

**Example 12: Incoming TOPS trunk group carrying a mix of all call types (toll)**

An example of datafill for a standard pretranslator subtable designated SPRT in a toll switching unit with TOPS is shown below.

This subtable can be assigned to TOPS trunk groups carrying a mix of all call types, that is 0-, 0+, 1+, and the call type is identified by the MF start signal.

Datafill is provided for the following digits:

0 to 1	On receipt of the first digit, translation routes to unauthorized CAMA treatment in the office treatment table.
2 to 8	If these digits are received as first digit, call type is identified by the MF start signal. Type of call is set to NL. The call is routed through national translation and to the operator.
9	All codes with the first digit equal to 9 are routed to CLLI OTWAON6789C0.

**STDPRTCT.STDPRT** (continued)

**MAP display example for table STDPRTCT.STDPRT**

FROMDIGS	TODIGS	PRETRTE
0	1	D UNCA
2	8	N NL 0 NA
9	9	S NL 0 OTWAON6789C0 5 5 NONE

**Example 13: Incoming TOPS trunk group carrying ONI 0- and 0+ calls (toll)**

An example of datafill for a standard pretranslator subtable designated PRT1 in a DMS-200 switching unit with TOPS is shown below.

This subtable can be assigned to TOPS trunk groups carrying a mix of 0- and 0+ calls only, and the trunk group is arranged for operator number identification (ONI).

Datafill is provided for the following digits:

0 to 1	On receipt of the first digit translation routes to unauthorized CAMA treatment in office treatment table.
2 to 8	If these digits are received as the first digit, call type is identified as operator assisted (OA). The call is routed through national translation and to the operator.
9	All codes with the first digit equal to 9 are routed to CLLI OTWAON5432C1.

**STDPRTCT.STDPRT** (continued)**MAP display example for table STDPRTCT.STDPRT**

FROMDIGS	TODIGS	PRETRTE
0	1	D UNCA
2	8	N OA 0 NA
9	9	S OA 0 OTWAON5432C1 5 5 NONE

**Example 14: Incoming TOPS trunk group carrying ONI 1+ calls (toll)**

An example of datafill for a standard pretranslator subtable designated PRT2 in a DMS-200 switching unit with the TOPS is shown below.

This subtable can be assigned to TOPS trunk groups carrying only 1+ calls, and the trunk group is arranged for ONI.

Datafill is provided for the following digits:

0 to 1	On receipt of the first digit, translation routes to an unauthorized CAMA treatment in the office treatment table.
2 to 8	If these digits are received as the first digit, call type is identified as direct dial (DD). The call is routed through national translation and to the operator.
9	All codes with the first digit equal to 9 are routed to CLLI OTWAON5432C1.

**STDPRTCT.STDPRT** (continued)

**MAP display example for table STDPRTCT.STDPRT**

FROMDIGS	TODIGS	PRETRTE
0	1	D UNCA
2	8	N DD 0 NA
9	9	S DD 0 OTWAON5432C1 5 5 NONE

**Example 15: Incoming CAMA trunk group with international calls (toll)**

An example of datafill for a pretranslator table (IFOS) assigned to an incoming CAMA trunk that carries international traffic and information traffic is shown below. The incoming digits are 13 for information calls (dialed digits are 113 with the first 1 absorbed by the SXS end office) and 1 followed by the country code and national number for operator assisted international calls (the dialed digits are 01 followed by the country code and national number with the 0 absorbed by the SXS end office).

The pretranslator is arranged to recognize the information call. Only two digits are received, while for an international call, 10, 11 or 12 digits are received.

For an information call, the pretranslator prefixes a 1 and routes it to the table HPNACODE for digit analysis. For international call, the pretranslator routes the call to international translations.

**MAP display example for table STDPRTCT.STDPRT**

FROMDIGS	TODIGS	PRETRTE
1	1	Z 2 NP 0 N NA 1 12 DD 0 N IN N

**Example 16: Incoming CCIS trunk groups (toll)**

An example of datafill for a standard pretranslator subtable designated C6TS, that is used in offices with Common Channel Interface Signaling No.6 (CCIS6) capability to route test calls is shown below.



**STDPRTCT.STDPRT** (continued)

Unlike other standard pretranslators, the C6TS pretranslator is not assigned on a trunk group basis. The pretranslator is automatically used by CCIS6 trunks (instead of the standard pretranslator associated with the trunk's group), whenever the calling party category indicator of the initial address message is of type TEST\_CALL. Note that a cold restart must be performed after C6TS has been added to the table SDTPRTCT and before any CCIS6 test calls are terminated on the switch.

C6TS is used to directly route CCIS6 test codes to the appropriate test card. The CCIS6 test codes are assigned as shown in the following table.

**CCIS6 test codes**

<b>Digits</b>	<b>Test type</b>
05	Switching maintenance center communication trunk (code 958)
06	Noise and balance termination (code 100)
07	Test board communication trunk (code 101)
08	Milliwatt 1000 Hz with timed disconnect (code 102)
10	Far-end transmission measurement and noise checking (code 104)
11	ATMS-type test termination (code 105)
14	Echo suppressor test termination (code 108)

The digits 07 can be followed by two digits, indicating the identity of the test position or the group of the test positions to which the test call is directed.

The digits 10 must only be routed to terminating test line #4 table entries (TTL4) that specify no-answer supervision.

**STDPRTCT.STDPRT** (continued)**MAP display example for table STDPRTCT.STDPRT**

FROMDIGS	TODIGS	PRETRTE
06	06	
S DD 2	TERM100Q	2 2 NONE
07	07	
S DD 2	T101	2 2 NONE
0700	0700	
S DD 4	T101	4 4 NONE
0701	0701	
S DD 4	T10101	4 4 NONE
08	08	
S DD 2	TERM102T	2 2 NONE
10	10	
T DD 2	TTL4 0	2 2 NONE
11	11	
S DD 2	TERM105	2 2 NONE
14	14	
S DD 2	TERM108	2 2 NONE

**Example 17: Dialable cable locator tone (local)**

An example of datafill for a standard pretranslator subtable for a dialable cable locator tone is shown below. DMS-100, upon receiving a security or an access code of 7863 followed by a seven-digit DN from any line circuit, provides the desired tone across the tip and ring leads of the dialed DN. The operating company's tone generator is accessed through a trunk group type MAINT having DCLTONE as the CLLI.

The number of prefix digits, (field NOPREDIG), is set to 4, the number of digits in the security or an access code is set to 7863.

The total number of digits is 11 (4 for security, or access code plus 7 for the DN). Fields MINDGSR and MAXDIGSR are set to 11.

**STDPRTCT.STDPRT** (continued)**MAP display example for table STDPRTCT.STDPRT**

FROMDIGS	TODIGS	PRETRTE
7863	7863	
S NP 4	LPBKOGL 11 11	NONE

**Example 18: New station ringer test (local)**

Translation of a call involving the new station ringer test proceeds as follows:

Subtable STDPRTCT.STDPRT

When the operating-company selects a new SRT code, for example 999, and it is verified that the total number of digits received is between 10 and 13 (10 being for new SRT access code of 3 digits + 7 digit DN and 13 for the new SRT access code of 3 digits + 3 digit NPA + 7 digit DN), translation is directed to table OFRT at route reference index 76.

**Table OFRT**

Route reference index 76 directs translation to fixed CLLI code STRG, previously entered in table CLLI.

**Table CLLI**

Refer to the description of table CLLI for information on the new fixed CLLI STRG.

An example of datafill for the standard pretranslator subtable is shown below.

**MAP display example for table STDPRTCT.STDPRT**

FROMDIGS	TODIGS	PRETRTE
999	999	
T NP 3	OFR3 76 7 7	NONE

**STDPRTCT.STDPRT** (continued)**Example 19: Feature group B call (local)**

An example of datafill for selector feature group B (FGB) is shown below. The first and second fields in this tuple define the digits that are translated at the FGB end office or the FGB tandem.

The FGB selector is used to identify a FGB call. The call type is direct dialed (DD) and the number of prefix digits is 0 (zero). CAR1 defines the carrier name (defined in table OCCNAME). Y (yes) indicates that there is a route present. OFRT is the name of the table that the call is routed to, and 897 is the route reference number assigned to the route in table OFRT.

The minimum and maximum number of digits that the end office must collect is 7, before it can outpulse information to the carrier.

**MAP display example for table STDPRTCT.STDPRT**

FROMDIGS	TODIGS	PRETRTE
9501777	9501777	
FGB DD 0 CAR1 Y OFRT 897 7 7		

**Example 20: Number service code call (AT SSP)**

800P is the service switching point service for the United States.

800P number service code (NSC) service only handles national equal access calls such that the from and to digits always appear in the national dialing format 0ZZXXX. This implies that field NSC\_TRAN is always set to NA for 800P calls.

**STDPRTCT.STDPRT** (continued)**MAP display example for table STDPRTCT.STDPRT**

FROMDIGS	TODIGS	PRETRTE
022110	02110	NSC DD 7 7 800P NA
034110	034110	NSC DD 7 7 PVN NA
147110	147110	NSC DD 9 9 PVN IN

**Example 21: Routing test calls incoming on ISUP trunks (office with ISUP capability)**

An example of datafill for a standard pretranslator C7PT that is used in offices with ISDN user parts (ISUP) capability to route test calls is shown below.

Unlike other standard pretranslators, the C7PT pretranslator is not assigned on a trunk group basis. The pretranslator is automatically used by ISUP trunks (instead of the standard pretranslator associated with the trunk's group), whenever the calling party category indicator of the initial address message (IAM) indicates that a test call is in progress.

**Note:**

The subtable STDPRTCT.STDPRT at position C7PT is used to directly route ISUP test codes to the appropriate test card. The ISUP test codes for this feature are assigned as shown in the following table.

**ISUP test codes**

Digits	Test type
06	Noise and balance termination (code 100)
08	Milliwatt at 1000 Hz with timed disconnect (code 102)
101	T101 test call
104	Transmission measuring and noise checking test
108	T108 test call

**STDPRTCT.STDPRT** (continued)

**MAP display example for table STDPRTCT.STDPRT**

FROMDIGS	TODIGS	PRETRTE
06	06	
	S DD 2	TERM100Q 2 2 NONE
08	08	
	S DD 2	TERM102T 2 2 NONE
101	101	
	S DD 3	T101 3 3 NONE
104	104	
	T DD 3	TTL4 0 3 3 NONE
108	108	
	S DD 3	TERM108 3 3 NONE

**Example 22: Feature group D (FGD) call (local)**

An example of datafill for feature group D (FGD) is shown below. This example has been datafilled for the following requirements:

- IT to IT FGD domestic translation: EATANDEMIC dials 099777
- IT to IT FGD international: EATANDEMIC dials 199777

**MAP display example for table STDPRTCT.STDPRT**

FROMDIGS	TODIGS	PRETRTE
099777	099777	
	ET NP 0	CARR1 Y OFRT 777 6 6
199777	199777	
	ET NP 0	CARR1 Y OFRT 777 9 9

**Example 23: International IBN**

The following is an example of datafill for a standard pretranslator subtable designated CUSB in an international Integrated Business Network (IBN) DMS switching unit.

**STDPRTCT.STDPRT** (continued)**MAP display example for table STDPRTCT.STDPRT**

FROMDIGS	TODIGS	PRETRTE
0	1600	D VACT
170	170	
	S DD 0 TERM100Q 3 3	NONE
178	178	
	N NP 0 NA 3 3	NONE
179	179	
	T DD 0 OFRT 106 3 3	NONE
18	192	D VACT
193	194	
	T DD 0 IBNRTE 20 3 3	NONE
195	195	D VACT
2	998	
	T DD 0 IBNRTE 8 7 7	NONE

**Example 24: Equal access end office**

The following examples illustrate the typical use of selector EA.

**Pretranslator P621****First stage pretranslation of access code 10120 (P621)**

In the first tuple of subtable STDPRTCT.STDPRT at EXTPRTNM(P621), selector fields PRERTSEL(EA) and XLATYPE(P) indicate that a call with leading digits FROM(10120) TO(10120) is routed to interconnect carrier CARRNAME(CARR1) through TABID(OFRT) KEY(100) unless otherwise specified in the second stage pretranslator PRTNM(OCC1) and provided the call does not encounter a treatment in translations following the second pretranslator.

Field NOPREDIG(5) sets the prefix fence at 5, which means that the second stage pretranslator translates the digits following 10120.

Field TYPCALL(DD) entry is overridden by the second pretranslator but it is here only to satisfy the table editor.

The number of digits expected is MIN(6) and MAX(24). The number of digits expected can be updated in further translations.

## **STDPRTCT.STDPRT** (continued)

---

### **First stage pretranslation of access code 10999 (P621)**

In the second tuple of subtable STDPRTCT.STDPRT at EXTPRTNM(P621), selector fields PRERTSEL(EA) and XLATYPE(P) indicate that a call with leading digits FROM(10999) TO(10999) is routed to interconnect carrier CARRNAME(CARR2) through second pretranslator PRTNM(OCC2).

Field RTEPRSNT(N) indicates that there is no route specified here. This means that unless otherwise specified in the second pretranslator, the call proceeds on the route or treatment encountered in translations following the second pretranslator.

Field NOPREDIG(5) sets the prefix fence at 5, which means that the second stage pretranslator translates digits following 10999.

Field TYPCALL(DD) entry is overridden by the second pretranslator but it is here only to satisfy the table editor.

### **9501XXX cut-through mode (P621)**

In the third tuple of subtable STDPRTCT.STDPRT at EXTPRTNM(P621), selector fields PRERTSEL(EA) and XLATYPE(T) indicate that a call with leading digits FROM(9501120) TO(9501120) is routed to interconnect carrier CARRNAME(CARR1) through TABID(OFRT) KEY(102), and field TRANSYS(NO) indicates that translation to verify the validity of the dialed digits is not required.

Fields MIN(7) and MAX(7) indicate that the number of digits expected is seven.

Field NOPREDIG(7) sets the prefix fence at 7. No digits are outputted since, in the cut-through mode, all signaling to the other common carrier (OCC) is by means of the subscriber's digitone keypad.



**STDPRTCT.STDPRT** (continued)**MAP display example for table STDPRTCT.STDPRT**

FROMDIGS	TODIGS	PRETRTE
10120	10120	
EA DD 5 P OCC1	CARR1 Y OFRT 100 6 24	N
10999	10999	
	EA DD 5 P OCC2	CARR2 N
9501120	9501120	
EA DD 7 T NO	CARR1 Y OFRT 102 7 7	N

**Pretranslator OCC1****Second stage pretranslation of direct dialed overseas calls (OCC1)**

In the first tuple of subtable SDPRTCT.STDPRT at EXTPRTNM(OCC1), selector fields PRERTSEL(EA) and XLATYPE(T) indicate that a call with leading digits FROM(011) TO(011) is routed to interconnect carrier CARRNAME(CARR1).

Field RTEPRSNT(N) indicates that there is no route specified here. Fields RTEPRSNT(N) and TRANSYS(IN) indicate that the call proceeds on the route specified in the first stage pretranslator EXTPRTNM(P621) TABID(OVRT) KEY(100) provided the call does not encounter a treatment in the international country code table CCTR. Table CCTR is used only to verify the validity of the dialed digits, while its routing recommendations for valid codes are ignored.

Field NOPREDIG(3) sets the prefix fence at 3, which means that table CCTR translates digits following 011, the international direct distance dialed access code.

Field TYPCALL(DD) defines the type of call as direct dialed.

**Second stage pretranslation of operator-assisted North American calls (OCC1)**

In the second tuple of subtable STDPRTCT.STDPRT at EXTPRTNM(OCC1), selector fields PRERTSEL(EA) and XLATYPE(T) indicate that a call with leading digits FROM(02) TO(09) is routed to interconnect carrier CARRNAME(CARR1).

Field RTEPRSNT(N) indicates that there is no route specified here. Fields RTEPRSNT(N) and TRANSYS(NA) indicate that the call proceeds on the route specified in the first stage pretranslator EXTPRTNM(P621)

**STDPRTCT.STDPRT** (continued)

---

TABID(OVRT) KEY(100) provided the call does not encounter a treatment in the North American digit translation tables HNPACONT.HNPACODE, FNPACONT.FNPACODE, LCASCRCN.LCASCRC, PFXTREAT, CLSVSCRC, and CLSVSCRC.CLSVSCR. The North American digit translation tables are used only to verify the validity of the dialed digits, while their routing recommendations for valid codes are ignored.

Field NOPREDIG(1) sets the prefix fence at 1, which means that the digits translated in the North American tables start after the 0 (zero) of FROM(02) TO(09).

Field TYPCALL(OA) defines the type of call as operator assisted.

**Second stage pretranslation of operator assisted overseas calls (OCC1)**

In the third tuple of subtable STDPRTCT.STDPRT at EXTPRTNM(OCC1), selector fields PRERTSEL(EA) and XLATYPE(T) and fields RTEPRSNT(Y) and TRANSYS(IN) indicate that a call with leading digits FROM(012) TO(019) is routed to interconnect carrier CARRNAME(CARR1) through TABID(OVRT) KEY(101) provided the call does not encounter a treatment in the international country code table CCTR. Table CCTR is used only to verify the validity of the dialed digits, while its routing recommendations for valid codes are ignored.

Field NOPREDIG(1) sets the prefix fence at 1, which means that the digits translated in the North American tables start after the 01 of FROM(012) TO(019).

Field TYPCALL(OA) defines the type of call as operator assisted.

**Second stage pretranslation of direct-dialed North American calls (OCC1)**

In the fourth tuple of subtable STDPRTCT.STDPRT at EXTPRTNM(OCC1), selector fields PRERTSEL(EA) and XLATYPE(T) indicate that a call with leading digits FROM(12) TO(19) is routed to interconnect carrier CARRNAME(CARR1).

Field RTEPRSNT(N) indicates that there is no route specified here. Fields RTEPRSNT(N) and TRANSYS(NA) indicate that the call proceeds on the route specified in the first stage pretranslator EXTPRTNM(P621) TABID(OVRT) KEY(100) provided the call does not encounter a treatment in the North American digit translation tables HNPACONT.HNPACODE, FNPACONT.FNPACODE, LCASCRCN.LCASCRC, PFXTREAT, CLSVSCRC and CLSVSCRC.CLSVSCR. The North American digit

**STDPRTCT.STDPRT** (continued)

translation tables are used only to verify the validity of the dialed digits, while their routing recommendations for valid codes are ignored.

Field NOPREDIG(1) sets the prefix fence at 1, which means that the digits translated in the North American tables start after the 1 of FROM(12) TO(19).

Field TYPCALL(DD) defines the type of call as direct dialed.

**MAP display example for table STDPRTCT.STDPRT**

FROMDIGS	TODIGS	PRETRTE
011	011	
	EA DD 3 T IN CARR1 N	
02	09	
	EA OA 1 T NA CARR1 N	
012	019	
OA 1 T IN CARR1	Y OFRT 101 6 24 N	
12	19	
	EA DD 1 T NA CARR1 N	

**Pretranslator OCC2****Second stage pretranslation of direct dialed North American calls (OCC2)**

In the first tuple of subtable STDPRTCT.STDPRT at EXTPRTNM(OCC2), selector fields PRERTSEL(EA) and XLATYPE(T) indicate that a call with leading digits FROM(12) TO(19) is routed to interconnect carrier CARRNAME(CARR2).

Field RTEPRSNT(N) indicates that there is no route specified here. Fields RTEPRSNT(N) and TRANSYS(NA) indicate that, since no route was specified in the first stage pretranslator, the call proceeds as specified in the North American digit translation tables HNPACONT.HNPACODE, HNPACONT.RTEREF, FNPACONT.FNPACODE, FNPACONT.RTEREF, LCASCRCN.LCASCRC, PFXTREAT, CLSVSCRC, and CLSVSCRC.CLSVSCR. The North American digit translation tables are used both to verify the validity of the dialed digits and for routing.

Field NOPREDIG(1) sets the prefix fence at 1, which means that the digits translated in the North American tables starts after the 1 of FROM(12) TO(19).

**STDPRTCT.STDPRT** (continued)

Field TYPALL(DD) defines the type of call as direct dialed.

**MAP display example for table STDPRTCT.STDPRT**

FROMDIGS	TODIGS	PRETRTE
12	19	EA DD 1 T NA CARR2 N

**Example 25: Selector E911 (Enhanced 911 Emergency Service)**

An example of datafill for pretranslator route selector E911 is shown below.

**MAP display example for table STDPRTCT.STDPRT**

FROMDIGS	TODIGS	PRETRTE
911	911	E911 123 443

**Example 26: Selector FGDCL for ANI and called number collection**

An example of datafill for pretranslator route selector FGDCL for automatic number identification (ANI) and called number collection is shown below.

**MAP display example for table STDPRTCT.STDPRT**

FROMDIGS	TODIGS	PRETRTE
022110	022110	FGDCL

**STDPRTCT.STDPRT** (continued)**Example 27: Selector ID for Meridian SuperNode**

An example of datafill for pretranslator route selector ID for Meridian SuperNode is shown below.

**MAP display example for table STDPRTCT.STDPRT**

FROMDIGS	TODIGS	PRETRTE
00	00	ID CONT
10	10	ID TEST
129	129	ID INTDD
02	02	ID STOP
99	99	ID ALTXLA BNRRCH 20

**Example 28: Selector SFMT for packet handler translations**

An example of datafill for selector SFMT is shown below.

**MAP display example for table STDPRTCT.STDPRT**

FROMDIGS	TODIGS	PRETRTE
1	1	SFMT 1 14 1 X P621 518

**Example 29: Selector E911RTE for Tandem-Tandem transfers**

An example of datafill for selector E911RTE is shown below.

**STDPRTCT.STDPRT** (continued)**MAP display example for table STDPRTCT.STDPRT**

```

>Table STDPRTCT
> POS P621
> SUB 2
> ADD
> FROMDIGS:
>911
TODIGS:
>911
PRERTSEL:
TYPE OF PRERTSEL IS PRET_ROUTE_SELECTOR
TYPE IS PRET_ROUTE_SELECTOR
{S,T,D,N,L,P,V,R,X,F,Z,EA,NSC,FGB,ET,E911,FGDCL,
                                     SFMT,SSP,E911RTE}

PRERTSEL:
>E911RTE
TYPCALL:
>OA
NOPREDIG:
>0
MINDIGSR:
>3
MAXDIGSR:
>7
TAB:
TYPE OF TAB IS TAB_NAME
TYPE IS TAB_NAME {E911TDRT}
TAB:
>E911TDRT
POS: NONE
>
TUPLE TO BE ADDED:
          911 911 E911RTE OA 0 3 7 E911TDRT NONE
ENTER Y TO CONFIRM, N TO REJECT OR E TO EDIT.
>Y
TUPLE ADDED

```

**Table history****NA015**

New E911 Tandem-Tandem Enhancements added selector E911RTE to subtable STDPRTCT.STDPRT.

**NA008**

Feature Equal Access for DMS-100 Wireless added information on datafilling separate pretranslators for EA on the DMS-100 Wireless switch in release LWW00805 (NA008).

---

**STDPRTCT.STDPRT** (end)

---

**NA006**

Increased maximum number of tuples using expansion data to 8,386,569.

**BCS36**

The following changes were made:

- Added new pretranslator route selector SSP.
- Increased upper limit of range of field MAXDIGSR to 25 for pretranslator route selector T.

## STDPRTCT.STDPRT selector D

### Pretranslator route selector: D

Use selector D to route translation directly to treatment. For this selector value, enter data in fields FROMDIGS, TODIGS, and PRETRTE as the data appears in the following table.

### Datafill

Datafill for table STDPRTCT.STDPRT selector D appears in the following table.

### Field descriptions

Field	Subfield or refinement	Entry	Explanation and action
FROMDIGS		numeric (vector of a maximum of 18 digits)	<i>From digits.</i> Enter the digit or digits to translate.  If the entry represents a block of numbers that follow in order, enter the first number in the block.
TODIGS		numeric (vector of a maximum of 18 digits)	<i>To digits.</i> If field FROMDIGS represents a block of numbers that follow in order, enter the last number in the block.  For all other conditions, the entry is the entry in field FROMDIGS.
PRETRTE		see subfield	<i>Pretranslation route.</i> This field contains subfield PRERTSEL and refinement TREAT.
	PRERTSEL	D	<i>Pretranslator route selector.</i> Enter the pretranslator route selector D.
	TREAT	alphanumeric (four characters)	<i>Treatment.</i> Enter the treatment in the office treatment table that is the route of the translation.

### Datafill example

Datafill for selector D appears in examples 3, 4, 5, 6, 7, 8, 9, 10, 11, 12, 13, 14, and 23. See the "Datafill example" section in table STDPRTCT.STDPRT.



---

## STDPRTCT.STDPRT selector E911

---

### Pretranslator route selector: E911

The system uses selector E911 in offices with the Enhanced 911 Emergency Service feature. The system uses selector E911 for 911 calls incoming on message and foreign exchange (FX) trunks (non-E911 trunks). Selector E911 specifies the following numbers:

- an emergency service number (ESN) indexed in table E911ESN. The ESN routes the call to the correct public safety answering point (PSAP) directory number (DN).
- an emergency service central office (ESCO) number. The ESCO number is used in the substitute automatic number identification (ANI). The E911 tandem forwards the substitute ANI to the PSAP.

The pretranslator selector E911 is not available for calls that originate from coin or non-coin lines. For coin-lines, the unit does not return the coin. The unit does not replace the coin as the PSAP DN replaces the called digits 911.

Substitute ANI format that the PSAP receives for message and FX trunks. This type of trunk does not spill ANI.

For PSAPs that use one information digit, the substitute ANI format appears in the following section:

- ID-911-TTTT: TTTT is the ESCO and ID is the digit zero or four.
- 4-911-TTTT: The system sends this substitute ANI format to the PSAP if the ESN points to a tuple in table E911ESN. The tuple has field FLASH set to Y (yes). The ID digit 4 allows the ANI display at the PSAP to flash.
- 0-911-TTTT: The system sends this substitute ANI format to the PSAP if the ESN points to a tuple in table E911ESN. The tuple has field FLASH set to N (no).

For PSAPs that use three information digits, the substitute ANI format appears in the following section:

NPA-911-TTTT:T TTT is the ESCO, and the numbering plan area (NPA) is the serving NPA of the incoming message or FX trunk group.

For selector value E911, enter data in the fields FROMDIGS, TODIGS, and PRETRTE. A description of how to enter data in these fields appears in the following paragraph.

---

**STDPRTCT.STDPRT selector E911 (end)**

---

**Datafill**

The datafill for table STDPRTCT.STDPRT selector E911 appears in the following table.

**Field descriptions**

Field	Subfield or refinement	Entry	Description
FROMDIGS		numeric	<i>From digits.</i> Enter the digit or digits for translation. If the entry represents a block of consecutive numbers, enter the first number in the block.
TODIGS		numeric	<i>To digits.</i> If field FROMDIGS represents a block of consecutive numbers, enter the last number in the block.  If field FROMDIGS does not represent a block of consecutive numbers, the entry is equal to the entry in field FROMDIGS.
PRETRTE		see the subfield	<i>Pretranslation route.</i> This field contains the subfield PRERTSEL and the refinements ESN and ESCO.
	PRERTSEL	E911	Pretranslator route selector. Enter E911.
	ESN	numeric 0 to 15 999	<i>Emergency service number.</i> Enter an emergency service number.  This emergency service number must be in table E911ESN, field ESN.
	ESCO	0000 to 9999 (four digits)	<i>Emergency service central office number.</i> Enter an emergency service central office number that represents the end office where the message or FX trunk group originates. The substitute ANI spill uses this end office.

**Datafill example**

Datafill for selector E911 appears in example 25. See the datafill example in table STDPRTCT.STDPRT.

---

## STDPRTCT.STDPRT selector EA

---

### Pretranslator route selector: EA

Selector EA translates equal access calls in one or two pretranslation stages.

The digit translation and routing options associated with selector EA are as follows:

- Additional digit translation is not a requirement. Field XLATYPE = N.  
Use of the specified key in table OFRT sends the call to the specified carrier. See figure Figure , "Standard pretranslator selector EA flowchart" on page -5.
- Additional pretranslation is a requirement. Field XLATYPE = P.  
The call proceeds to a second-stage pretranslator. This action is correct if the call encounters selector EA for the first time while translating a call.  
You can specify a first-stage key in table OFRT. This key overrides any routing prescription except the treatment the call encounters in translations and screening that follows pretranslation. This condition occurs unless translation encounters another key in the second-stage pretranslation. See figure 1.
- Verify if the dialed digits are correct. Field XLATYPE = T.

Additional digit translation is a requirement after pretranslation to verify if the received digits are correct. To verify if the digits are international or North American, the system uses the following:

- international digit translations (table CCTR)
- North American digit translations and screening

The system attempts verification in this order. The system uses the following tables to perform the verification using North American digit translations and screening:

- HNPACONT.HNPACODE
- FNPACONT.FNPACODE
- LCASCRCN.LCASCRC
- PFXTREAT
- SCRNCCLAS
- CLSVSCRC
- CLSVSCRC.CLSVSCR

The system can use all of these table to perform the verification.

## **STDPRTCT.STDPRT selector EA** (continued)

---

### **Recursive translation**

Equal Access translation does not support more than six digits in the recursive translation. Equal Access translation occurs before all digits are collected. The entry of a maximum number of digits can occur in all Equal Access pretranslators. This maximum is 1+6 digits for a 1+10 digit call, and 1+3 digits for a 1+7 digit call. The call may not complete properly if this maximum is exceeded.

You can specify a second-stage or single-stage key in table OFRT. This key overrides any routing prescription except a treatment the call encounters in translations and screening that follows pretranslation. See figure Figure , "Standard pretranslator selector EA flowchart" on page -5.

**STDPRTCT.STDPRT selector EA (continued)**

**Standard pretranslator selector EA flowchart**

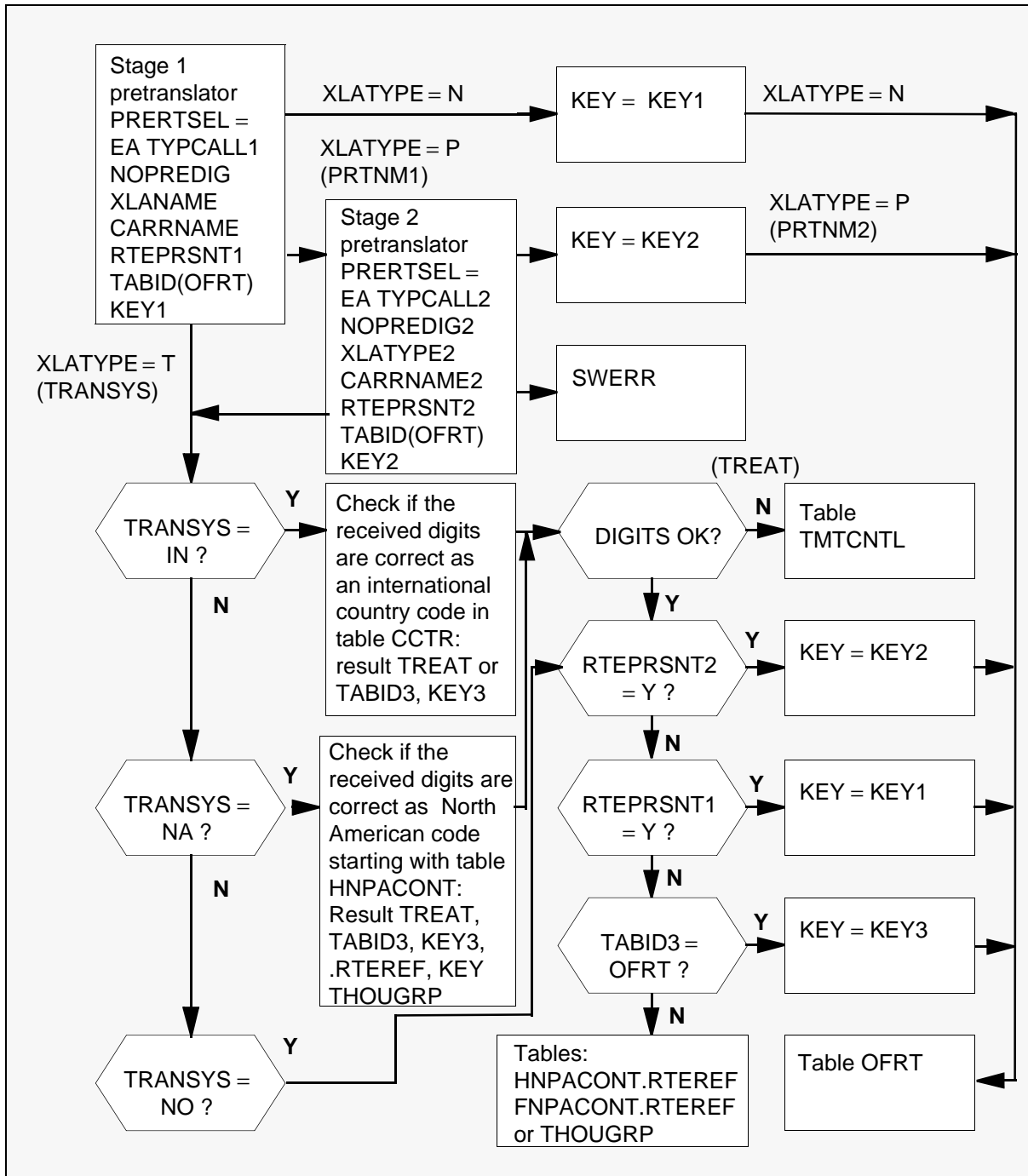

For selector value EA, enter data in subfields FROMDIGS, TODIGS, and PRETRTE. The following table explains the data entry process.

**STDPRTCT.STDPRT selector EA** (continued)

**Datafill**

Datafill for table STDPRTCT.STDPRT selector EA appears in the following table.

**Field descriptions**

Field	Subfield or refinement	Entry	Explanation and action
FROMDIGS		numeric (vector of a maximum of 18 digits)	<i>From digits</i> Enter the digit or digits to translate.  If the entry represents a block of consecutive numbers, enter the first number in the block.
TODIGS		numeric (vector of a maximum of 18 digits)	<i>To digits.</i> If field FROMDIGS represents a block of consecutive numbers, enter the last number in the block.  If field FROMDIGS does not represent a block of consecutive numbers, the entry equals the entry in field FROMDIGS.
PRETRTE		see subfield	<i>Pretranslation route.</i> This field contains subfield PRERTSEL and refinements TYPCALL, NOPREDIG, XLA_INFO, CARRNAME, and RTEAREA.
	PRERTSEL	EA	<i>Pretranslator route selector.</i> Enter the equal-access route selector EA.
	TYPCALL	DD, NL, NP, or OA	<i>Type of call.</i> Enter the type of call. Call types are DD (direct dial), NL (nil), NP (no prefix), and OA (operator assisted). Default is NL.
	NOPREDIG	0 to 7	<i>Number of prefix digits.</i> Enter the number of digits interpreted as prefix digits.

**STDPRTCT.STDPRT selector EA** (continued)**Field descriptions**

Field	Subfield or refinement	Entry	Explanation and action
	XLA_INFO	see subfield	<p><i>Equal access translation information.</i> This field contains subfield XLATYPE and the following refinements:</p> <ul style="list-style-type: none"> <li>• If XLATYPE = N, refinements are not present.</li> <li>• If XLATYPE = P, the refinement is PRTNM.</li> <li>• If XLATYPE = T, the refinement is TRANSYS.</li> </ul>
	XLATYPE	N, P, or T	<p><i>Equal access translation type.</i> Enter N if additional digit translation or screening is a requirement. If the entry is N, field RTEAREA must specify a route.</p> <p>Enter P if additional pretranslation is a requirement. This entry is correct if PRERTSEL = EA occurs for the first time. If the entry is P, you must enter a pretranslator subtable name in field PRTNM.</p> <p>Enter T if additional pretranslation is not a requirement. If the entry is T, the entry in field TRANSYS determines how translations proceed.</p>

**XLATYPE = P**

If the value of subfield XLATYPE is P, enter data in refinement PRTNM. The following table explains the data entry process.

**Field descriptions for conditional datafill**

Field	Subfield or refinement	Entry	Explanation and action
	PRTNM	alphanumeric (a maximum of four characters)	<p><i>Pretranslator subtable name.</i> Enter the name of the pretranslator subtable for pretranslation of the remaining digits. Translation must route to the pretranslator subtable.</p>

---

## STDPRTCT.STDPRT selector EA (continued)

---

### **XLATYPE = T**

If the value of subfield XLATYPE is T, enter data in refinement TRANSYS.  
The following table explains the data entry process.

#### **Field descriptions for conditional datafill**

<b>Field</b>	<b>Subfield or refinement</b>	<b>Entry</b>	<b>Explanation and action</b>
	TRANSYS	IN, IP, NA, NO	<p><i>Translation system.</i> Enter IN if translation is to proceed to international translations.</p> <p>Enter IP if translation is to route to international partitioned translations. This condition applies to DMS-250 switches only.</p> <p>Enter NA if translation is to proceed to North American digit translations and screening.</p> <p>Enter NO if additional translation or screening is not a requirement. This condition is equivalent to XLATYPE = N.</p>

#### **Field descriptions**

<b>Field</b>	<b>Subfield or refinement</b>	<b>Entry</b>	<b>Explanation and action</b>
	CARRNAME	alphanumeric (1 to 16 characters)	<p><i>Carrier name.</i> Enter the carrier name abbreviation to which the system offers the call. Enter the carrier name in table OCCNAME.</p>



**STDPRTCT.STDPRT selector EA** (continued)**Field descriptions**

Field	Subfield or refinement	Entry	Explanation and action
	RTEAREA	see subfield	<p><i>Route area.</i> This field contains subfield RTEPRSNT and the following refinements:</p> <ul style="list-style-type: none"> <li>• If RTEPRSNT = Y, the refinements are EXTRTEID, MINDIGSR, MAXDIGSR, and OCS.</li> <li>• If RTEPRSNT = N, refinements are not present.</li> </ul> <p>See the general description and figure Figure , "Standard pretranslator selector EA flowchart" on page -5.</p>
	RTEPRSNT	Y or N	<p><i>Route present.</i> Enter Y (yes) to indicate that fields EXTRTEID, MINDIGSR, MAXDIGSR, and OCS contain entries.</p> <p>Enter N (no) to indicate that fields EXTRTEID, MINDIGSR, MAXDIGSR, and OCS are blank.</p>

**RTEPRSNT = Y**

If the entry in field RTEPRSNT is Y, enter data in the fields that appear in the following table.

**Field descriptions for conditional datafill**

Field	Subfield or refinement	Entry	Explanation and action
	EXTRTEID	see subfields	<i>External route ID.</i> This field contains subfields TABID and KEY.
	TABID	OFRT, OFR2, OFR3, OFR4 IBNRTE, IBNRTE2, IBNRTE3, IBNRTE4, TOPS RRTE, TTL4, TOPSAMA	<i>Table identifier.</i> Enter an office route table name.

## STDPRTCT.STDPRT selector EA (continued)

### Field descriptions for conditional datafill

Field	Subfield or refinement	Entry	Explanation and action
	KEY	0 to 1023	<p><i>Index.</i> Enter the office route index of the call the system routes.</p> <p><b>Note 1:</b> If field XLATYPE = P, the route overrides routing recommendations in subsequent digit translations other than treatments. The route overrides routing recommendations unless superseded in the second-stage pretranslator. Field XLATYPE=P is correct only if field PRERTSEL = EA occurs for the first time while translating a call.</p> <p><b>Note 2:</b> If field XLATYPE = T, the route overrides routing recommendations in subsequent digit translations other than treatments. Field XLATYPE is second-stage or single stage pretranslator.</p>
	MINDIGSR	0 to 18	<p><i>Minimum digits received.</i> Enter the minimum number of digits collected before routing the call.</p>
	MAXDIGSR	0 to 30	<p><i>Maximum digits received.</i> This refinement equals the maximum number of digits for collection. This number does not include IBN prefix digits. Enter the maximum number of digits for collection. Do not include IBN prefix digits.</p>
	OCS	Y or N	<p><i>Overlap carrier selection.</i> If field RTEPRSNT = Y, and field OVERLAP in table OCCINFO is Y, the call uses overlap carrier selection.</p>

### Datafill example

Datafill for selector EA appears in example 24. Refer to the Datafill example section in table STDPRTCT.STDPRT.

### Additional information

This section provides information on error messages when you enter data in table STDPRTCT.STDPRT selector EA.

---

**STDPRTCT.STDPRT selector EA (end)**

---

If you enter field MAXDIGSR with a number greater than 25, the following error message appears:

\*\*\*\*\*WARNING\*\*\*\*\*THE MAXIMUM  
NUMBER OF DIGITS (INCLUDING 15 INTERNATIONAL DIALING  
PLAN DIGITS) IS 25. SETTING THE FIELD MAXDIGSR GREATER  
THAN 25 MAY HAVE SERIOUS CONSEQUENCES.

Reduce the MAXDIGSR datafill total to a maximum of 25.

## STDPRTCT.STDPRT selector ET

### Pretranslator route selector: ET

The system uses selector ET on feature group D (FGD) calls in a special equal access end office (EAEO). This EAEO is an equal access switching point (EASP). Selector ET tandems equal access calls between a current EAEO and an access tandem (AT).

For selector value ET, enter data in the subfields FROMDIGS, TODIGS, and PRETRTE. A description of this process appears in the following section.

### Datafill

Datafill for table STDPRTCT.STDPRT selector ET appears in the following table.

#### Field descriptions (Sheet 1 of 2)

Field	Subfield or refinement	Entry	Description
FROMDIGS		numeric	<i>From digits.</i> Enter the digit or digits for translation.  If the entry represents a block of consecutive numbers, enter the first number in the block.
TODIGS		numeric	<i>To digits.</i> If FROMDIGS represents a block of consecutive numbers, enter the last number in the block. If FROMDIGS does not represent a block of consecutive numbers, the entry is equal to FROMDIGS.
PRETRTE		see the subfield	<i>Pretranslation route.</i> This field contains the subfield PRERTSEL. This field contains refinements TYPCALL, NOPREDIG, CARRNAME, RTEAREA, RTEPRSNT, EXTRTEID, MINDIGSR, and MAXDIGSR.
	PRERTSEL	ET	<i>Pretranslator route selector.</i> Enter pretranslator route selector ET.
	TYPCALL	DD, NL, NP, or OA	<i>Type of call.</i> Enter NP because billing does not occur in the EASP.
	NOPREDIG	0 to 7	<i>Number of prefix digits.</i> Enter the number of digits that the system interprets as prefix digits.

**STDPRTCT.STDPRT selector ET** (continued)

## Field descriptions (Sheet 2 of 2)

Field	Subfield or refinement	Entry	Description
	CARRNAME	alphanumeric (1 to 16 characters)	<i>Carrier name.</i> Enter the carrier name abbreviation to which the system offers the call. Table OCCNAME must contain the carrier name.
	RTEAREA	see subfields	<i>Route area.</i> This field contains the subfields RTEPRSNT, EXTRTEID, MINDIGSR, and MAXDIGSR.
	RTEPRSNT	Y or N	<i>Route present.</i> Enter Y if the system sends a call to a route from pretranslation. Enter data in fields EXTRTEID, MINDIGSR and MAXDIGSR.  Enter N if a national translation (table HNPACONT) must follow. Leave fields EXTRTEID, MINDIGSR and MAXDIGSR blank.
	EXTRTEID	see subfields	<i>External route identifier.</i> This field contains the subfields TABID and KEY.
	TABID	OFRT, OFR2, OFR3, OFR4 IBNRTE, IBNRTE2, IBNRTE3, IBNRTE4, TOPS, TOPSAMA RRTE, TTL4	<i>Table name.</i> Enter an office route table name for additional call routing.
	KEY	0 to 1023	<i>Index.</i> Enter the office route index of the routed call.
	MINDIGSR	0 to 124	<i>Minimum digits received.</i> Enter the minimum number of digits that the system collects before the system routes the call.
	MAXDIGSR	0 to 124	<i>Maximum digits received.</i> Enter the maximum number of digits that the system must collect.

## **STDPRTCT.STDPRT selector ET (end)**

---

### **Datafill example**

Datafill for selector ET appears in example 22. See the "Datafill example" section in table STDPRTCT.STDPRT.

**STDPRTCT.STDPRT selector F****Pretranslator route selector: F**

The system uses selector F if a second dial tone or recycling for more digits is a requirement. For this selector value, enter data in the fields FROMDIGS, TODIGS, and PRETRTE. A description of this process appears below.

**Note:** The selector F can be in use with 950 dialing and 950 type calls. When this event occurs, the system delays digit reception 10 to 15 s during the processing of the call.

**Datafill**

The datafill for table STDPRTCT.STDPRT selector F appears in the following table.

**Field descriptions (Sheet 1 of 2)**

Field	Subfield or refinement	Entry	Explanation and action
FROMDIGS		numeric	<i>From digits.</i> Enter the digit or digits before sending a dial tone.  If the entry represents a block of consecutive numbers, enter the first number in the block.
TODIGS		numeric	<i>To digits.</i> If field FROMDIGS represents a block of consecutive numbers, enter the last number in the block.  If field FROMDIGS does not represent a block of consecutive numbers, the entry is equal to the entry in field FROMDIGS.
PRETRTE		see subfield	<i>Pretranslation route.</i> This field contains the subfield PRERTSEL and the refinements NUMDIGSIN, DTONETYPE, and PRETRANSYS.
	PRERTSEL	F	<i>Pretranslator route selector.</i> Enter the second dial tone pretranslation selector F.
	NUMDIGSIN	0 to 7	<i>Number of digits.</i> Enter the number of digits the system received before sending dial tone.

---

**STDPRTCT.STDPRT selector F (end)**

---

**Field descriptions (Sheet 2 of 2)**

Field	Subfield or refinement	Entry	Explanation and action
	DTONETYPE	NORM SPEC STUTTER- DIALTONEor NONE	<i>Dial tone type.</i> Enter the type of dial tone required: normal (NORM), special (SPEC), or no dial tone (NONE ).
	PRETRANSYS	alphanumeric (1 to 4 characters)	<i>Pretranslator.</i> Enter the name of the pretranslator that translation must route for pretranslation of the remaining digits.

**Datafill example**

Datafill for selector F appears in examples 1 and 2. See the “Datafill examples” section in table STDPRTCT.STDPRT.



## STDPRTCT.STDPRT selector FGB

### Pretranslator route selector: FGB

Selector FGB identifies feature group B (FGB) calls (950-WXXX dialing) in the translation stage of the calls. This identification distinguishes FGB calls terminating on intertoll trunks from other call types.

For selector value FGB, enter data in fields FROMDIGS, TODIGS, and PRETRTE. A description of this process appears in the following table.

### Datafill

The datafill for table STDPRTCT.STDPRT selector FGB appears in the following table.

#### Field descriptions (Sheet 1 of 3)

Field	Subfield or refinement	Entry	Explanation and action
FROMDIGS		numeric	<i>From digits.</i> Enter the digit or digits for translation.  If the entry represents a block of numbers in sequence, enter the first number in the block.
TODIGS		numeric	<i>To digits.</i> If field FROMDIGS represents a block of numbers in sequence, enter the last number in the block.  If field FROMDIGS does not represent a block of consecutive numbers, the entry is equal to the entry in field FROMDIGS.
PRETRTE		see subfields	<i>Pretranslation route.</i> This field contains the subfield PRERTSEL and the following refinements: <ul style="list-style-type: none"> <li>• TYPCALL</li> <li>• NOPREDIG</li> <li>• CARRNAME</li> <li>• RTEAREA</li> <li>• RTEPRSNT</li> <li>• EXTRTEID</li> <li>• MINDIGSR</li> <li>• MAXDIGSR</li> </ul>

**STDPRTCT.STDPRT selector FGB** (continued)

## Field descriptions (Sheet 2 of 3)

Field	Subfield or refinement	Entry	Explanation and action
	PRERTSEL	FGB	<i>Pretranslator route selector.</i> Enter pretranslator route selector FGB.
	TYPCALL	DD, NL, NP, or OA	<i>Type of call.</i> Enter the type of call: direct dial (DD), nil (NL), no prefix (NP), or operator assisted (OA).
	NOPREDIG	0 to 7	<i>Number of prefix digits.</i> Enter the number of digits that the system interprets as prefix digits.  The arrangement of the switching unit can support circle digit operation. When this event occurs, the circle digit must be in the number of prefix digits removed from the digit translation.
	CARRNAME	alphanumeric (1 to 16 characters)	<i>Carrier name.</i> Enter the carrier name abbreviation where the call is offered. The carrier name must be in table OCCNAME.
	RTEAREA	see subfields	<i>Route area.</i> This field contains the subfields RTEPRSNT, EXTRTEID, MINDIGSR, and MAXDIGSR.
	RTEPRSNT	Y or N	<i>Route present.</i> Enter Y, if the system sends a call to a route from pretranslation. Enter data in all remaining fields.  Enter N, if a national translation (table HNPACONT) route must follow. Leave the remaining fields blank.
	EXTRTEID	see subfields	<i>External route identifier.</i> This field contains the subfields TABID and KEY.
	TABID	OFRT, OFR2, OFR3, OFR4, IBNRTE, IBNRTE2, IBNRTE3, IBNRTE4, TOPSAMA, RRTE, TTL4, TOPS	<i>Table name.</i> Enter an office route table name.  The office route table name contains the route for the feature group B (FGB) call.

**STDPRTCT.STDPRT selector FGB (end)****Field descriptions (Sheet 3 of 3)**

<b>Field</b>	<b>Subfield or refinement</b>	<b>Entry</b>	<b>Explanation and action</b>
	KEY	1 to 1023	<i>Index.</i> Enter the office route index where the system routes the call.  Entries outside this range are not correct.
	MINDIGSR	0 to 18	<i>Minimum digits received.</i> Enter the minimum number of digits that the system collects before the system routes the call.
	MAXDIGSR	0 to 18	<i>Maximum digits received.</i> Enter the maximum number of digits that the system collects.

**Datafill example**

Datafill for selector FGB appears in example 19. See the "Datafill examples" section in table STDPRTCT.STDPRT.

## STDPRTCT.STDPRT selector FGDCL

---

### Pretranslator route selector: FGDCL

An access tandem (AT) uses selector FGDCL to handle calls incoming from an equal access end office (EAEO). The EAEO uses feature group D (FGD) multifrequency (MF) signaling. This process requires automatic number identification (ANI) and called number collection and translation.

The translation result, FGDCL of the first-stage digits (0ZZXXX), triggers the ANI and called number collection. After ANI and called number collection, retranslating the called number determines the route for the call.

Support for FGDCL is only available on intertoll (IT) or super CAMA (SC) trunk group types.

An SC trunk supports calling number identification, direct dial (DD) billing, and local calling area screening. The following rules apply to an FGDCL call from an SC trunk:

- If the ANI information digit (II) includes an operator number identification (ONI) (01) or ANI (02) failure indicator calling number identification by a Centralized Automatic Message Accounting (CAMA) position is not available.
- The datafill in subtable STDPRTCT.STDPRT field CALLTYPE determines the DD billing. If field CALLTYPE is DD (billable), the system produces an AMA record. If field CALLTYPE is NP, the system does not produce an Automatic Message Accounting (AMA) record unless table TRKGRP GRPTYP(SC) field RECORDNP is Y.
- Local calling area screening is not performed on the call.

For selector value FGDCL, enter data in fields FROMDIGS, TODIGS, and PRETRTE. A description of this process appears in the following table.

**STDPRTCT.STDPRT selector FGDCL (end)****Datafill**

The datafill for table STDPRTCT.STDPRT selector FGDCL appears in the following table.

**Field descriptions**

Field	Subfield or refinement	Entry	Explanation and action
FROMDIGS		numeric	<i>From digits.</i> Enter the digit or digits before sending the dial tone.  If the entry represents a block of numbers in sequence, enter the first number in the block.
TODIGS		numeric	<i>To digits.</i> If field FROMDIGS represents a block of numbers in sequence, enter the last number in the block.  If field FROMDIGS does not represent a block of numbers in sequence, the entry is equal to the entry in field FROMDIGS.
PRETRTE		see subfield	<i>Pretranslation route.</i> This field contains subfield PRERTSEL.
	PRERTSEL	FGDCL	<i>Pretranslator route selector.</i> Enter the pretranslation route selector FGDCL.

**Datafill example**

Datafill for selector FGDCL appears in example 26. See the "Datafill examples" section in table STDPRTCT.STDPRT.

## STDPRTCT.STDPRT selector ID

### Pretranslator route selector: ID

A Meridian SuperNode uses a selector ID to translate feature group D (FGD) automatic number identification (ANI) ID digits. The selector ID also translates the INX code in the first digit stream of an FGD international call. The INX code consists of routing digits that appear in the first digit stream of an international call, where N = 1 to 9 and X = 0 to 9.

For selector value ID, enter data in the fields FROMDIGS, TODIGS, and PRETRTE. A description of how to enter data in these fields appears in the following section.

### Datafill

Datafill for table STDPRTCT.STDPRT selector ID appears in the following table.

#### Field descriptions (Sheet 1 of 2)

Field	Subfield or refinement	Entry	Description
FROMDIGS		numeric	<i>From digits.</i> Enter the digit or digits for translation.  If the entry represents a block of consecutive numbers, enter the first number in the block.
TODIGS		numeric	<i>To digits.</i> If field FROMDIGS represents a block of consecutive numbers, enter the last number in the block.  If field FROMDIGS does not represent a block of consecutive numbers, the entry is equal to the entry in field FROMDIGS.
PRETRTE		see the subfield	<i>Pretranslation route.</i> This field contains the subfield PRERTSEL and the refinement CALLCOND.
	PRERTSEL	ID	<i>Pretranslator route selector.</i> Enter the pretranslation route selector ID.

**STDPRTCT.STDPRT selector ID (end)****Field descriptions (Sheet 2 of 2)**

Field	Subfield or refinement	Entry	Description
	CALLCOND	ALTXLA CONT INTDD STOP or TEST	<p><i>Pretranslator route selector.</i> Enter one of the following values:</p> <p>Enter CONT to continue translation.</p> <p>Enter INTDD for international direct dialed calls. Use this result for the 1NX code of an international direct dialed call.</p> <p>Enter STOP to stop translation and block the call.</p> <p>Enter TEST if information digits specify that this call is a test call.</p> <p>Enter ALTXLA if an alternate translation scheme is specified for the call. Enter data in fields ALTCUST and ALTNCOS.</p>
ALTCUST		alphanumeric	<i>Alternate customer group</i> Enter the alternate customer group name that replaces the current customer group name is used for translation.
ALTNCOS		0 to 511	<i>Alternate network class of service.</i> Enter the NCOS that replaces the current NCOS in use for translation.

**Datafill example**

Datafill for selector ID appears in example 27. See the "Datafill examples" section in table STDPRTCT.STDPRT.

## STDPRTCT.STDPRT selector L

### Pretranslator route selector: L

The system uses selector L if seven digits arrive from an incoming trunk group. The system uses selector L if direct access to the directory number translation is a requirement. The system does not use selector L with trunk group type intertoll (IT).

For selector value L, enter fields FROMDIGS, TODIGS, and PRETRTE. A description of this process appears in the following table.

### Datafill

Datafill for table STDPRTCT.STDPRT selector L appears in the following table.

#### Field descriptions (Sheet 1 of 2)

Field	Subfield or refinement	Entry	Explanation and action
FROMDIGS		numeric	<i>From digits</i> Enter the digit or digits translated. If the entry represents a block of following numbers, enter the first number in the block.
TODIGS		numeric	<i>To digits</i> If field FROMDIGS represents a block of following numbers enter the last number in the block. For other conditions, the entry is equal to the entry in field FROMDIGS.
PRETRTE		see subfields	<i>Pretranslation route</i> This field contains subfield PRERTSEL. This field contains refinements TYPCALL, NOPREDIG, SNPA, and NNX.
	PRERTSEL	L	<i>Pretranslator route selector</i> Enter pretranslator route selector L.
	TYPCALL	DD, NL, NP, or OA	<i>Type of call</i> Enter the type of call: direct dial (DD), nil (NL), no prefix (NP), or operator assisted (OA).



**STDPRTCT.STDPRT selector L (end)****Field descriptions (Sheet 2 of 2)**

Field	Subfield or refinement	Entry	Explanation and action
	NOPREDIG		<p><i>Number of prefix digits</i> Enter the number of digits interpreted as prefix digits.</p> <p>The switching unit can be for circle digit operation. When this condition applies, the number of prefix digits removed from the digit translation must include the circle digit.</p> <p>See table LENLINES description for examples of entries for a standard pretranslator for a local/toll switching unit for circle digit operation. See examples S and T.</p>
	SNPA		<p><i>Serving numbering plan area</i> Enter the serving NPA with the terminating NNX.</p>
	NNX		<p><i>NNX code</i> Enter the NNX code of the called directory number (DN).</p>

**Datafill example**

Datafill for selector L appears in example 7. Refer to the "Datafill example" section in table STDPRTCT.STDPRT.

## STDPRTCT.STDPRT selector N

### Pretranslator route selector: N

The system uses selector N if translation must route to national, subtable HNPACONT.HNPACODE, or international, table CCTR, translations.

For selector value N, enter fields FROMDIGS, TODIGS, and PRETRTE. A description of this process appears in the following table.

### Datafill

Datafill for table STDPRTCT.STDPRT selector N appears in the following table.

#### Field descriptions (Sheet 1 of 2)

Field	Subfield or refinement	Entry	Explanation and action
FROMDIGS		numeric	<i>From digits</i> Enter the digit or digits that the system must translate.  If the entry represents a block of consecutive numbers, enter the first number in the block.
TODIGS		numeric	<i>To digits</i> If field FROMDIGS represents a block of consecutive numbers, enter the last number in the block.  For other conditions, the entry is equal to the entry in field FROMDIGS.
PRETRTE		see subfield	<i>Pretranslation route</i> This field contains subfield PRERTSEL. This field contains refinements TYPCALL, NOPREDIG, and TRANSYS.
	PRERTSEL	N	<i>Pretranslator route selector</i> Enter pretranslator route selector N.
	TYPCALL	DD, NL, NP, or OA	<i>Type of call</i> Enter the type of call: direct dial (DD), nil (NL), no prefix (NP), or operated assisted (OA). For Traffic Operator Position System (TOPS) calls, there can be a mix of 0 and 1 call types. These call types are OA and DD.  Enter NL for these conditions.

**STDPRTCT.STDPRT selector N (end)****Field descriptions (Sheet 2 of 2)**

<b>Field</b>	<b>Subfield or refinement</b>	<b>Entry</b>	<b>Explanation and action</b>
	NOPREDIG	0 to 7	<p><i>Number of prefix digits</i> Enter the number of digits interpreted as prefix digits.</p> <p>The switching unit can be for circle digit operation. When this condition applies, the number of prefix digits removed from the digit translation must include the circle digit.</p> <p>See table LENLINES description for examples of entries for a standard pretranslator for a local/toll switching unit for circle digit operation. See examples S and T.</p>
	TRANSYS	IN, NO, NA, or IP	<p><i>Translation system</i> Enter IN if translation routes to international translations, local/toll switching unit only.</p> <p>Enter IP if translation routes to international partitioned translations, DMS-250 only.</p> <p>Enter NA if translation routes to national translations.</p>

**Datafill example**

Datafill for selector N appears in examples 1, 3, 5, 6, 9, 11, 12, 13, 14, and 23. Refer to the "Datafill example" section in table STDPRTCT.STDPRT.

## STDPRTCT.STDPRT selector NSC

### Pretranslator route selector: NSC

The system uses selector NSC in an access tandem (AT) service switching point (SSP). Selector NSC detects number service code (NSC) calls from an equal access (EA) end office (EAEO) through EA signaling. The EAEO outpulses the sequence KP+0ZZ+XXX+ST with a special code XXX. The code indicates the call is an NSC call. The XXX must be equal to table OFCENG parameter SSP\_NSC\_CARRIER\_ID. The default value for SSP\_NSC\_CARRIER\_ID is 000.

The NSC provides inward call management features that require access to operating company databases. The current installations of the NSC feature are as follows:

- Enhanced 800 (E800) service in a switch with the E800 package
- 800+ (800P) service in a switch with the 800P package
- Private Virtual Network (PVN) Service in a switch with the PVN package

See the description of table NSCDEFS for information on the NSC tables.

For selector value NSC, enter fields FROMDIGS, TODIGS, and PRETRTE. A description of this process appears in the following table.

### Datafill

Datafill for table STDPRTCT.STDPRT selector NSC appears in the following table.

#### Field descriptions (Sheet 1 of 2)

Field	Subfield or refinement	Entry	Explanation and action
FROMDIGS		numeric	<i>From digits</i> Enter the six or seven digits that outpulse from the EAEO with the format 0ZZXXX. The XXX must be equal to table OFCENG parameter SSP_NSC_CARRIER_ID.  The default value for parameter SSP_NSC_CARRIER_ID is 000.
TODIGS		numeric	<i>To digits</i> Enter the same entry as in field FROMDIGS.

**STDPRTCT.STDPRT selector NSC** (continued)

## Field descriptions (Sheet 2 of 2)

Field	Subfield or refinement	Entry	Explanation and action
PRETRTE		see subfields	<i>Pretranslation route</i> This field contains subfield PRERTSEL. This field contains refinements TYPCALL, MINDIGS, MAXDIGS, and NSCCODE.
	PRERTSEL	NSC	<i>Pretranslator route selector</i> Enter pretranslator route selector NSC.
	TYPCALL	DD, NL, NP, or OA	<i>Type of call</i> Enter DD for NSC call in AT SSP. Enter NP for NSC call in AT SSP Traffic Operator Position System (TOPS) office.
	MINDIGS	0 to 18	<i>Minimum digits received</i> Enter 7 as the minimum number of digits to collect before routing the NSC call.
	MAXDIGS	0 to 18	<i>Maximum digits received</i> Enter 7 as the maximum number of digits to collect.
	NSCCODE	E800, 800P, PVN, VPN, REPLDIGS, or AIN	<i>Number service code</i> Enter the NSC that you must enter in table NSCDEFS, field NSCODE.  Enter E800 for the Enhanced 800 Service in a switch with the E800 package.  Enter 800P for 800 Plus Service in a switch with the 800P package.  Enter PVN for Private Virtual Network Service in a switch with the PVN package.
NSC_TRAN		IN, IP, NA, or NO	<i>NSC translation system</i> Enter NA for national NSC calls.  Enter IN for international NSC calls.  <b>Note:</b> The E800 and 800P services only handle national equal access calls. This condition causes FROMDIGS and TODIGS to appear in the national dialing format 0ZZXXX. Field NSC_TRAN always contains NA for E800 and 800P calls.

## **STDPRTCT.STDPRT selector NSC (end)**

---

### **Datafill example**

Datafill for selector NSC appears in example 20. Refer to the "Datafill example" section in table STDPRTCT.STDPRT.

---

**STDPRTCT.STDPRT selector P**

---

**Pretranslator route selector: P**

The system uses selector P if a call that proceeds to specified national or international digit translations requires operator intervention. National digit translations can be subtable HNPACONT.HNPACODE. International digit translations can be table CCTR. In this condition the DMS software does not automatically provide for operator intervention. The system uses selector P in combined local/toll switching units with Traffic Operator Position System (TOPS) on calls that subscriber lines originate. These calls require TOPS operator intervention.

The translations are as follows:

- The dialed digits are translated as for selector N using national or international translations.
- If the result of the translation is a treatment, the call terminates as a treatment without the intervention of the TOPS operator. For other conditions, the result is not a treatment and table POSITION is looked up at the index field POS specifies. To determine the index in table POSITION, entered in field POS, consider the following options.

The DMS switch can be a combined local/toll with TOPS without the equal access options. The originator of the call can be a 1FR plain ordinary telephone service (POTS), coin, or hotel line. When these conditions are present, the selected entry in table POSITION must point to field CLLI = TOPSPOS. The call connects directly to a TOPS position.

For other conditions, the system must route the call to an outgoing trunk group of type OP that loops back. This action allows the OP to come in as a trunk group of type TOPS.

For selector value P, enter fields FROMDIGS, TODIGS, and PRETRTE. A description of this process appears in the following table.

**STDPRTCT.STDPRT selector P** (continued)**Datafill**

Datafill for table STDPRTCT.STDPRT selector P appears in the following table.

**Field descriptions (Sheet 1 of 2)**

Field	Subfield or refinement	Entry	Explanation and action
FROMDIGS		numeric	<i>From digits</i> Enter the digit or digits to translate.  If the entry represents a block of consecutive numbers, enter the first number in the block.
TODIGS		numeric	<i>To digits</i> If field FROMDIGS represents a block of consecutive numbers, enter the last number in the block.  For other conditions, the entry is equal to the entry in field FROMDIGS.
PRETRTE		see subfield	<i>Pretranslation route</i> This field contains subfield PRERTSEL. This field contains refinements TYPCALL, NOPREDIG, TRANSYS, and POS.
	PRERTSEL	P	<i>Pretranslator route selector</i> Enter pretranslator route selector P.
	TYPCALL	DD, NP, or OA	<i>Type of call</i> Enter the type of call: direct dial (DD), no prefix (NP), or operator assisted (OA).
NOPREDIG	NOPREDIG	0 to 7	<i>Number of prefix digits</i> Enter the number of digits to interpret as prefix digits.  The switching unit can be for circle digit operation. When this condition applies, the number of prefix digits to remove from the digit translation must include the circle digit.  See table LENLINES description for examples of entries for a standard pretranslator for a local/toll switching unit for circle digit operation. See examples S and T.



**STDPRTCT.STDPRT selector P** (end)**Field descriptions (Sheet 2 of 2)**

<b>Field</b>	<b>Subfield or refinement</b>	<b>Entry</b>	<b>Explanation and action</b>
	TRANSYS	IN, IP, NO, or NA	<p><i>Translation system</i> Enter IN if translation routes to international translations, local/toll switching unit only.</p> <p>Enter IP if the translation routes to international partitioned translations, DMS-250 only.</p> <p>Enter NA if translation routes to national translations.</p>
	POS	alphanumeric	<p><i>Position</i> Enter the type of position in the table POSITION to which the system routes the translation.</p>

## STDPRTCT.STDPRT selector R

### Pretranslator route selector: R

Use of selector R occurs if the specified 3 to 11 digits replace the dialed digits.

For selector value R, enter data fields FROMDIGS, TODIGS, and PRETRTE. This process appears in the following section.

### Datafill

Datafill for table STDPRTCT.STDPRT selector R appears in the following table.

#### Field descriptions (Sheet 1 of 2)

Field	Subfield or refinement	Entry	Explanation and action
FROMDIGS		numeric	<i>From digits.</i> Enter the digit or digits to translate.  If the entry represents a block of numbers that follow each other, enter the first number in the block.
TODIGS		numeric	<i>To digits.</i> If field FROMDIGS represents a block of numbers that follow each other, enter the last number in the block.  In other conditions, the entry is equal to the entry in field FROMDIGS.
PRETRTE		see subfield	<i>Pretranslation route.</i> This field contains subfield PRERTSEL and refinements TYPCALL, NOPREDIG, TRANSYS, REPLCODE, and POS.
	PRERTSEL	R	<i>Pretranslator route selector.</i> Enter pretranslator route selector R.
	TYPCALL	DD, NL, NP, or OA	<i>Type of call.</i> Enter the type of call: DD (direct dial), NL (nil), NP (no prefix), or OA (operator assisted).

**STDPRTCT.STDPRT selector R (end)****Field descriptions (Sheet 2 of 2)**

Field	Subfield or refinement	Entry	Explanation and action
	NOPREDIG	0 to 7	<p><i>Number of prefix digits.</i> Enter the number of digits that the system translates as prefix digits.</p> <p>Arrangement of the switching unit can be for circle digit operation. When this even occurs, the number of prefix digits removed from the digit translation must include the circle digit.</p> <p>Refer to examples of entries for a standard pretranslator for a local/toll switching unit arranged for circle digit operation. To refer to these examples, refer to the description of table LENLINES, examples S and T.</p>
	TRANSYS	IN, IP, NO, or NA	<p><i>Translation system.</i> Enter IN if the system must route translation to international translations. This action applies to local/toll switching unit only.</p> <p>Enter IP if the system must route translation to international partitioned translations, DMS-250 only.</p> <p>Enter NA if the system routes translation to national translations.</p>
	REPLCODE	numeric 3 to 11 digits	<p><i>Replacement code.</i> Enter the digits to replace the digits field FROMDIGS specifies.</p>
	POS	alphanumeric or NONE	<p><i>Position local/toll.</i> In a local/toll switching unit, enter the type of position in table POSITION to which the system routes translation.</p> <p>In other conditions, the value of this field is NONE.</p>

**Datafill example**

Datafill for selector R appears in examples 3, 4, and 5. See the "Datafill example" section in table STDPRTCT.STDPRT.

## STDPRTCT.STDPRT selector S

### Pretranslator route selector: S

Use of selector S occurs if the system must route translation directly to a common language location identifier (CLLI).

For selector value S, enter data in fields FROMDIGS, TODIGS, and PRETRTE. This process appears in the following section.

### Datafill

Datafill for table STDPRTCT.STDPRT selector S appears in the following table.

#### Field descriptions (Sheet 1 of 2)

Field	Subfield or refinement	Entry	Explanation and action
FROMDIGS		numeric	<i>From digits.</i> Enter the digit or digits to translate.  If the entry represents a block of numbers that follow each other, enter the first number in the block.
TODIGS		numeric	<i>To digits.</i> If field FROMDIGS represents a block of numbers that follow each other, enter the last number in the block.  In other conditions, the entry is equal to the entry in field FROMDIGS.
PRETRTE		see subfield	<i>Pretranslation route.</i> This field contains subfield PRERTSEL and refinements TYPCALL, NOPREDIG, CLLI, MINDIGSR, MAXDIGSR and POS.
	PRERTSEL	S	<i>Pretranslator route selector.</i> Enter pretranslator route selector S.
	TYPCALL	DD, NL, NP, or OA	<i>Type of call.</i> Enter the type of call. The type of call can be DD (direct dial), NL (nil), NP (no prefix), or OA (operator assisted).

**STDPRTCT.STDPRT selector S** (end)

## Field descriptions (Sheet 2 of 2)

Field	Subfield or refinement	Entry	Explanation and action
	NOPREDIG	0 to 7	<p><i>Number of prefix digits.</i> Enter the number of digits that the system translates as prefix digits.</p> <p>Arrangement of the switching unit can be for circle digit operation. When this event occurs, the number of prefix digits removed from the digit translation must include the circle digit.</p> <p>Examples are present for entries for a standard pretranslator for a local/toll switching unit arranged for circle digit operation. For these examples, refer to the description of table LENLINES, examples S and T.</p> <p><b>Note:</b> Use of selectors cannot occur if assignment of pretranslator to Traffic Operator Position System (TOPS) occurs and the type of call is DD (TYPCALL = DD).</p>
	CLLI	alphanumeric	<p><i>Common language location identifier.</i> Enter the code in table CLLI to which the system routes translation.</p>
	MINDIGSR	0 to 18	<p><i>Minimum digits received.</i> Enter the minimum number of digits collected before the system routesthecall.</p>
	MAXDIGSR	0 to 18	<p><i>Maximum digits received.</i> Enter the maximum number of digits collected.</p>
	POS	alphanumeric	<p><i>Position.</i> In a local/toll switching unit, enter the type of position in table POSITION to which the system routes translation.</p> <p>In other conditions, the value of this field is NONE.</p>

**Datafill example**

Datafill for selector S appears in examples 2, 3, 4, 5, 7, 11, 12, 13, 14, 16, 17, and 23. Refer to the "Datafill example" section in table STDPRTCT.STDPRT.

## STDPRTCT.STDPRT selector SFMT

### Pretranslator route selector: SFMT

Use of selector SFMT occurs if the system must route translation directly to a DMS packet handler switching system.

For selector value SFMT, enter data in fields FROMDIGS, TODIGS, and PRETRTE. This process appears in the following section.

### Datafill

Datafill for table STDPRTCT.STDPRT selector SFMT appears in the following table.

#### Field descriptions (Sheet 1 of 3)

Field	Subfield or refinement	Entry	Explanation and action
FROMDIGS		numeric	<i>From digits.</i> Enter the digit or digits to translate.  If the entry represents a block of numbers that follow each other, enter the first number in the block.
TODIGS		numeric	<i>To digits.</i> If field FROMDIGS represents a block of numbers that follow each other, enter the last number in the block.  In other conditions, the entry is equal to the entry in field FROMDIGS.
PRETRTE		see subfield	<i>Pretranslation route.</i> This field contains subfield PRERTSEL and refinements MINDIGS, MAXDIGS, ESC_DIGITS, and XLA_OR_RTE.
	PRERTSEL	SFMT	<i>Pretranslator route selector.</i> Enter pretranslator route selector SFMT.
	MINDIGS	1 to 18	<i>Minimum digits received.</i> Enter the minimum number of digits collected before the system routes the call.
	MAXDIGS	1 to 18	<i>Maximum digits received.</i> Enter the maximum number of digits collected.

**STDPRTCT.STDPRT selector SFMT** (continued)

## Field descriptions (Sheet 2 of 3)

Field	Subfield or refinement	Entry	Explanation and action
	ESC_DIGITS	0 to 7	<i>Number of escape digits.</i> Enter the number of digits that the system translates as escape digits.
	XLA_OR_RTE		<p><b>Note:</b> Use of this selector cannot occur if assignment of pretranslator TOPS occurs and the type of call TYPSCALL = DD.</p> <p><i>Translate or route.</i> This field contains selectors X and R.</p> <p>If the selector is X, enter XLA and datafill for subfields PRTM and STS.</p> <p>If the selector is R, enter CROUTE.</p> <p>If you enter CROUTE, choose entry S or T.</p> <p>If you enter CROUTE and S, enter CS and enter data for subfield CLLI.</p> <p>If you enter CROUTE and T, enter CT and enter data for subfields TABID and KEY.</p>
RTESSEL		R	<i>Route entry.</i> Enter R.
		CROUTE	<i>Route entry.</i> Enter CROUTE.
		S or T	<p><i>Route selector.</i> Enter S and enter data for subfield CLLI to route to a CLLI.</p> <p>Enter T and enter data for subfields TABID and KEY to route to a office route or an IBN route.</p>
	CLLI	alphanumeric 1 to 16 characters	<p><i>Common location language identifier.</i> Enter the CLLI to which the system routes the call.</p> <p>You must enter this entry in table CLLI before you can enter this entry in this field.</p>

---

**STDPRTCT.STDPRT selector SFMT (end)**

---

**Field descriptions (Sheet 3 of 3)**

Field	Subfield or refinement	Entry	Explanation and action
	TABID	OFRT, OFR2, OFR3, OFR4, IBNRTE, IBNRT1, IBNRT2, IBNRT3, or IBNRT4	<p><i>Table identifier.</i> Enter the office route or IBN route table name to which translation proceeds.</p> <p>Entries outside of this range are not correct.</p>
	KEY	1 to 1023	<p><i>Key.</i> Enter the index in the routing table to which translation proceeds.</p> <p>Entries outside of this range are not correct.</p>

**Datafill example**

Datafill for selector SFMT appears in example 28. Refer to the "Datafill examples" section in table STDPRTCT.STDPRT.



---

**STDPRTCT.STDPRT selector SSP**

---

**Pretranslator route selector: SSP**

Pretranslator route selector SSP indicates if service switching point (SSP) processing is a requirement for an equal access (EA) call. This call has functional group D (FGD) signaling.

The FROMDIGS and TODIGS fields are the 0ZZXXXX digits that must match from the first stage of the three-stage FGD signaling. The XXXX digits must be 0110 for this selector. If following call processing interruption does not occur, call processing attempts to terminate the call. An example of call processing interruption is an absence of advanced intelligence network (AIN) triggering. Call processing uses the called digits from the last stage of the FGD signaling to terminate the call. The last stage of the FGD signaling is the third stage.

For selector value SSP, datafill fields FROMDIGS, TODIGS, and PRETRTE.

**Datafill**

Datafill for table STDPRTCT.STDPRT selector SSP appears in the following table.

**Field descriptions (Sheet 1 of 2)**

Field	Subfield or refinement	Entry	Explanation and action
FROMDIGS		numeric	<i>From digits.</i> Enter the digit or digits to translate.
TODIGS		numeric	<i>To digits.</i> Enter the digit or digits that you entered in field FROMDIGS.
PRETRTE		see subfield	<i>Pretranslation route.</i> This field contains subfield PRERTSEL and refinements TYPCALL, MINDIGS, MAXDIGS, and SSP_TRAN.
	PRERTSEL	SSP	<i>Pretranslator route selector.</i> Enter pretranslator route selector SSP.
	TYPCALL	DD, NL, NP, or OA	<i>Type of call.</i> Enter the type of call. Call types are direct dial (DD), nil (NL), no prefix (NP), or operator assisted (OA).

---

**STDPRTCT.STDPRT selector SSP (end)**

---

**Field descriptions (Sheet 2 of 2)**

<b>Field</b>	<b>Subfield or refinement</b>	<b>Entry</b>	<b>Explanation and action</b>
	MINDIGS	6 or 7	<i>Minimum digits received.</i> Enter the minimum number of digits collected before routing the call.
	MAXDIGS	6 or 7	<i>Maximum digits received.</i> The MAXDIGS is equal to the entry in field MINDIGS.
	SSP_TRAN	IN, IP, NA, or NO	<i>SSP translation system.</i> Enter NA for national SSP calls.  Enter IN for international SSP calls.

## STDPRTCT.STDPRT selector T

### Pretranslator route selector: T

Use of selector T occurs if the system must route translation directly to a test line or office route table.

For selector value T, enter data in fields FROMDIGS, TODIGS, and PRETRTE. This process appears in the following section.

### Datafill

Datafill for table STDPRTCT.STDPRT selector T appears in the following table.

#### Field descriptions (Sheet 1 of 3)

Field	Subfield or refinement	Entry	Explanation and action
FROMDIGS		numeric	<i>From digits.</i> Enter the digit or digits translated.  If the entry represents a block of numbers that follow each other, enter the first number in the block.
TODIGS		numeric	<i>To digits.</i> If field FROMDIGS represents a block of numbers that follow each other, enter the last number in the block.  In other conditions, the entry is equal to the entry in field FROMDIGS.
PRETRTE		see subfield	<i>Pretranslation route.</i> This field contains subfield PRERTSEL and refinements TYPCALL, NOPREDIG, EXTRTEID, MINDIGSR, MAXDIGSR, and POS.
	PRERTSEL	T	<i>Pretranslator route selector.</i> Enter pretranslator route selector T.  <b>Note:</b> Use of selector T cannot occur if assignment of pretranslator to Traffic Operator Position System (TOPS) occurs and the type of call is DD (TYPCALL = DD).
	TYPCALL	DD, NL, NP, or OA	<i>Type of call.</i> Enter the type of call: DD (direct dial), NL (nil), NP (no prefix), or OA (operator assisted).

**STDPRTCT.STDPRT selector T** (continued)

## Field descriptions (Sheet 2 of 3)

Field	Subfield or refinement	Entry	Explanation and action
	NOPREDIG	0 to 7	<p><i>Number of prefix digits.</i> Enter the number of digits that the system translates as prefix digits.</p> <p>If arrangement of the switching unit is for circle digit operation. When this event occurs, the number of prefix digits removed from the digit translation must include the circle digit.</p> <p>Entries for a standard pretranslator for a local/toll switching unit arranged for circle digit operation have examples. For these examples, refer to the description of table LENLINES, examples S and T.</p>
	EXTRTEID	alphanumeric	<p><i>External route identifier.</i> This field contains subfields TABID and KEY.</p>
	TABID	OFRT, OFR2, OFR3, OFR4, TTL4, TOPS, IBNRTE, or TOPSAMA	<p><i>Table name.</i> Enter the table name to which the system routes translation.</p> <p>Enter OFRT, OFR2, OFR3, or OFR4 for an office route.</p> <p>Enter TTL4 for terminating 104 test line.</p> <p>Enter TOPS to direct directory-assistance (DA) and intercept calls to a TOPS Multipurpose (MP) position. These features must be in a TOPS office with the TOPS MP system only.</p> <p>Enter IBNRTE for an Integrated Business Network (IBN) route, in an international IBN office only.</p>
	KEY	0 to 1023	<p><i>Index.</i> Enter the index in the specified table to which the system routes translation.</p> <p>If the table is an office route table, enter the route reference number, 1 to 1023.</p> <p>If the table is terminating test line TTL4, enter the index, 0 to 15.</p> <p>If the table is TOPS, enter the value of field CO (call origination), in table TOPS.</p>

**STDPRTCT.STDPRT selector T (end)****Field descriptions (Sheet 3 of 3)**

Field	Subfield or refinement	Entry	Explanation and action
	MINDIGSR	0 to 18	<i>Minimum digits received.</i> Enter the minimum number of digits collected before the system routes the call.
	MAXDIGSR	0 to 24	<i>Maximum digits received.</i> Enter the maximum number of digits collected.
	POS	alphanumeric	<i>Position.</i> In a local/toll switching unit, enter the type of position in table POSITION to which the system routes translation.  In other conditions, the value of this field is NONE.

**Datafill example**

Datafill for selector T appears in examples 7, 16, and 23. Refer to the "Datafill example" section in table STDPRTCT.STDPRT.

## STDPRTCT.STDPRT selector V

### Pretranslator route selector: V

If the number of digits expected on an incoming trunk group is variable, use Selector V. When the minimum and maximum number of digits received are fixed, use Selector V.

*Note:* To allow variable digit reception on the incoming trunk groups field VDESEL in table TRKGRP is Y. Variable digit reception can occur on trunk group types OP, TI, T2, TD, OI, A5, OC.

For selector value V, enter data in fields FROMDIGS, TODIGS, and PRETRTE. A description of this process appears in the following table.

### Datafill

Datafill for table STDPRTCT.STDPRT selector V appears in the following table.

#### Field descriptions (Sheet 1 of 3)

Field	Subfield or refinement	Entry	Explanation and action
FROMDIGS		numeric	<p><i>From digits.</i> Enter the digit or digits translated.</p> <p>If the entry represents a block of numbers, enter the first number in the block.</p> <p>If field PRERTSEL equals V and CASE1 follows, enter data in this field.</p> <p>If CASE2 follows field PRERTSEL, leave field blank.</p>
TODIGS		numeric	<p><i>To digits.</i> If field FROMDIGS contains a block of numbers, enter the last number in the block.</p> <p>The entry is equal to entry in field FROMDIGS.</p> <p>If field PRERTSEL equals V, enter this field if CASE1 follows.</p> <p>If CASE 2 follows field PRERTSEL, leave the field blank.</p>
PRETRTE		see subfield	<p><i>Pretranslator route.</i> This field contains subfield PRERTSEL and refinements CASE1 and CASE2.</p>

**STDPRTCT.STDPRT selector V** (continued)

## Field descriptions (Sheet 2 of 3)

Field	Subfield or refinement	Entry	Explanation and action
	PRERTSEL	V	<i>Pretranslator route selector.</i> Enter pretranslator route selector V (replaces selector X) if CASE1 follows. If CASE2 follows, leave field blank.
	CASE1	see subfields	<p><i>Minimum digits received.</i> This field contains the following subfields:</p> <ul style="list-style-type: none"> <li>• DIGSIN</li> <li>• TYPCALL</li> <li>• NOPREDIG</li> <li>• RTESEL</li> <li>• TABID</li> <li>• KEY</li> <li>• SNPA</li> <li>• NNX</li> <li>• THOUDIG</li> <li>• TRANSYS</li> <li>• DIGSREGEN</li> </ul> <p>The entries in the above subfields refer to calls that receive the minimum number of digits.</p> <p>Calls with less than the minimum number of digits proceed to treatment partial dial (PDIL).</p>
	DIGSIN	0 to 18	<p><i>Minimum number of incoming digits (case1).</i> Enter the minimum number of incoming digits.</p> <p>If field RTESEL equals L, the entry in field DIGSIN must be a minimum of 3.</p>
	TYPCALL	DD, NL, NP, or OA	<i>Type of call (case1).</i> Enter the type of call: direct dial (DD), nil (NL), no prefix (NP), or operator assisted (OA).

**STDPRTCT.STDPRT selector V** (continued)

## Field descriptions (Sheet 3 of 3)

Field	Subfield or refinement	Entry	Explanation and action
	NOPREDIG	0 to 7	<p><i>Number of prefix digits (case1).</i> Enter the number of digits that are prefix digits.</p> <p>If the switching unit is for circle digit operation, include the circle digit in the number of prefix digits. These digits are the prefix digits removed from the digit translation.</p> <p>For examples of entries for a standard pretranslator refer to the description of table LENLINES, examples S and T. The entries are for a standard pretranslator for a local/toll switching unit that is for circle digit operation.</p>
	RTESEL	T, L, or N	<p><i>Route selector (case1).</i> If translation routes to a table and index, enter T and enter refinement RTEID. A description of refinement RTEID follows. Refinement RTEID contains subfields TABID and KEY.</p> <p><b>Note:</b> If assigning pretranslator to TOPS and the type of call is DD (TYPCALL = DD), do not use Selector V.</p> <p>If translation routes to the directory number (DN) table, enter L. Enter data in refinements SNPA, NNX, and THOUDIG. A description of this process follows.</p> <p>If translation routes to table HNPACODE (national translations) or table CCTR (international translations), enter N. Enter data in refinements TRANSYS and DIGSREGEN. A description of this process appears on page follows.</p>



**STDPRTCT.STDPRT selector V** (continued)**RTESEL = T**

If the entry in field RTESEL is T, enter data in refinement RTEID. A description of this process appears in the following table.

**Field descriptions for conditional datafill**

Field	Subfield or refinement	Entry	Explanation and action
	RTEID	see subfields	<i>Route name.</i> This field contains subfields TABID and KEY.
	TABID	OFRT, IBNRTE, IBNRTE2, IBNRTE3, IBNRTE4, TOPS, RRTE, TTL4, TOPSAMA	<i>Table name (case1).</i> Enter the office route table name that the translation routes to.
	KEY	0 to 1023	<i>Index (case1).</i> Enter the index in the office route table that the translation routes to.

**RTESEL = L**

If the entry in field RTESEL is L, enter data in refinements SNPA, NNX, and THOUDIG. A description of this process appears in the following table.

**Field descriptions for conditional datafill**

Field	Subfield or refinement	Entry	Explanation and action
	SNPA	numeric	<i>Serving numbering plan area (case1).</i> Enter the serving NPA of the terminating NNX.
	NNX	numeric (table of 3 digits)	<i>NNX code (case1).</i> Enter the NNX code of the called directory number.
	THOUDIG	0 to 9, B to F, or N	<i>Thousands digit (case1).</i> If field DIGSIN equals 3, enter the thousands digit of the subscriber number.  If DIGSIN equals 4 or more, enter N.

**STDPRTCT.STDPRT selector V** (continued)**RTESEL = N**

If the entry in field RTESEL is N, enter data in refinements TRANSYS and DIGSREGEN. A description of this process appears in the following table.

**Field descriptions for conditional datafill**

Field	Subfield or refinement	Entry	Explanation and action
	TRANSYS	NO, NA, IN, or IP	<p><i>Translation system (case1).</i> Enter NA if translation must route to national translations.</p> <p>Enter IN if translation must route to international translations (local/toll switching unit only).</p> <p>Enter IP if translation must route to international partitioned translations (DMS-250 only).</p>
	DIGSREGEN	numeric (a maximum of 4 digits) or N	<p><i>Digit regeneration (case1).</i> If field PRERTSEL equals N, enter the digits of the prefix to the digits that generate a number. This number is for the digit analysis in the national or international translation.</p>

**STDPRTCT.STDPRT selector V** (continued)**For all route selector V tuples**

For all route selector V tuples, enter data in the additional fields that appear in the following table.

**Field descriptions (Sheet 1 of 2)**

Field	Subfield or refinement	Entry	Explanation and action
CASE2		see subfields	<p><i>Maximum digits received.</i> This field contains the following subfields:</p> <ul style="list-style-type: none"> <li>• DIGSIN</li> <li>• TYPCALL</li> <li>• NOPREDIG</li> <li>• RTESEL</li> <li>• TABID</li> <li>• KEY</li> <li>• SNPA</li> <li>• NNX</li> <li>• THOUDIG</li> <li>• TRANSYS</li> <li>• DIGSREGEN</li> </ul> <p>The entries in the above subfields refer to calls that receive the maximum number of digits.</p> <p>Calls with less than the maximum number of digits proceed to treatment partial dial (PDIL). These calls have greater than the minimum number of digits.</p>
	DIGSIN	0 to 18	<i>Maximum number of incoming digits (case2).</i> Enter the maximum number of incoming digits.
	TYPCALL	DD, NL, NP, or OA	<i>Type of call (case2).</i> Enter the type of call: direct dial (DD), nil (NL), no prefix (NP), or operator assisted (OA).

---

**STDPRTCT.STDPRT selector V** (continued)

---

## Field descriptions (Sheet 2 of 2)

Field	Subfield or refinement	Entry	Explanation and action
	NOPREDIG	0 to 7	<p><i>Number of prefix digits (case2).</i> Enter the number of digits that are prefix digits.</p> <p>If the switching unit is for circle digit operation, include the circle digit. Include this digit in the number of removed prefix digits from the digit translation.</p> <p>For examples of entries for a standard pretranslator refer to the description of table LENLINES, examples S and T. The entries are for a standard pretranslator for a local/toll switching unit that is for circle digit operation.</p>
	RTESEL	T, L, or N	<p><i>Route selector (case2).</i> If translation routes to a table and index, enter T and enter refinement RTEID. Enter data in refinement RTEID. A description of this process follows. Refinement RTEID contains subfields TABID and KEY.</p> <p><b>Note:</b> The use of selector V cannot occur if the assignment of the pretranslator to Traffic Operator Position System (TOPS) occurs and the type of call is DD (TYPCALL = DD).</p> <p>If translation routes to the directory number (DN) table, enter L. Enter data in refinements SNPA, NNX, and THOUDIG. A description of this process follows.</p> <p>If translation routes to table HNPACODE (national translations) or table CCTR (international translations), enter N. Enter data in refinements TRANSYS and DIGSREGEN. A description of this process follows .</p>

**STDPRTCT.STDPRT selector V** (continued)**RTESEL = T**

If the entry in field RTESEL is T, enter data in refinement RTEID. A description of this process appears in the following table.

**Field descriptions for conditional datafill**

Field	Subfield or refinement	Entry	Explanation and action
	RTEID	see subfields	<i>Route name.</i> This field contains subfields TABID and KEY.
	TABID	OFRT, IBNRTE, IBNRTE2, IBNRTE3, IBNRTE4, TOPSAMA, RRTE, TTL4	<i>Table name (case2).</i> Enter the office route table name that the translation routes to.
	KEY	0 to 1023	<i>Index (case2).</i> Enter the index in the office route table that the translation routes to.

**RTESEL = L**

If the entry field RTESEL is L, enter data in refinements SNPA, NNX, and THOUDIG. A description of this process appears in the following table.

**Field descriptions for conditional datafill**

Field	Subfield or refinement	Entry	Explanation and action
	SNPA	numeric	<i>Serving numbering plan area (case2)</i> Enter the serving NPA of the terminating NNX.
	NNX	numeric (table of 3 digits)	<i>NNX code (case2)</i> Enter the NNX code of the called directory number.
	THOUDIG	0 to 9, B to F, or N	<i>Thousands digit (case2)</i> If field DIGSIN equals 3, enter the thousands digit of the subscriber number.  If DIGSIN equals 4 or more, enter N.

---

**STDPRTCT.STDPRT selector V (end)**

---

**RTESEL = N**

If the entry field RTESEL is N, enter data in refinements TRANSYS and DIGSREGEN. A description of this process appears in the following table.

**Field descriptions for conditional datafill**

Field	Subfield or refinement	Entry	Explanation and action
	TRANSYS	NO, NA, IN, or IP	<p><i>Translation system (case2).</i> Enter NA if translation routes to national translations.</p> <p>Enter IN if translation routes to international translations (local/toll switching unit only).</p> <p>Enter IP if translation routes to international partitioned translations (DMS-250 only).</p>
	DIGSREGEN	numeric (a maximum of 4 digits)	<p><i>Digit regeneration (case2).</i> Enter the digits of the prefix to the digits that generate a number. This number is for digit analysis in the national or international translation.</p>

**Datafill example**

Datafill for selector V appears in examples 8, 10, and 11. See the "Datafill example" section in table STDPRTCT.STDPRT.

---

**STDPRTCT.STDPRT selector Z**

---

**Pretranslator route selector: Z**

Selector Z is in use if the following conditions occur:

- the number of digits expected on an incoming trunk group is variable
- the minimum number of digits received is fixed
- the maximum number of digits is variable

*Note:* To enable variable digit reception on the incoming trunk group, field VDESEL in table TRKGRP must contain Y (yes).

Variable digit reception can occur on trunk group types OP, TI, T2, TD, OI, A5, and OC.

For selector value Z, enter data into fields FROMDIGS, TODIGS, and PRETRTE. These fields appear in the following table.

**STDPRTCT.STDPRT selector Z** (continued)**Datafill**

The datafill for table STDPRTCT.STDPRT selector Z appears in the following table.

**Field descriptions (Sheet 1 of 3)**

Field	Subfield or refinement	Entry	Explanation and action
FROMDIGS		numeric	<p><i>From digits.</i> Enter the digit or digits translated.</p> <p>If the entry represents a block of consecutive numbers, enter the first number in the block.</p> <p>If field PRERTSEL equals Z, enter data into this field if field CASE1 follows this field.</p> <p>If field CASE2 follows this field, leave this field blank.</p>
TODIGS		numeric	<p><i>To digits.</i> If field FROMDIGS represents a block of consecutive numbers, enter the last number in the block.</p> <p>If field FROMDIGS does not represent a block of consecutive numbers, the entry is equal to the entry in field FROMDIGS.</p> <p>If field PRERTSEL equals Z, enter data into this field if CASE1 follows this field.</p> <p>If field CASE2 follows this field, leave this field blank.</p>
PRETRTE		see subfield	<p><i>Pretranslator route.</i> This field contains subfield PRERTSEL and the refinements CASE1 and CASE2.</p>
	PRERTSEL	Z	<p><i>Pretranslator route selector.</i> Enter pretranslator route selector Z. Enter data into this field if this field follows field CASE1. If field CASE2 follows this field, leave this field blank.</p>



**STDPRTCT.STDPRT selector Z** (continued)

## Field descriptions (Sheet 2 of 3)

Field	Subfield or refinement	Entry	Explanation and action
	CASE1	see subfields	<p><i>Minimum digits received.</i> This field contains the following subfields: DIGSIN, TYPCALL, NOPREDIG, RTESEL, TABID, KEY, SNPA, NNX, THOUDIG, TRANSYS, DIGSREGEN, and CONTMARK.</p> <p>The entries in the above subfields associate with calls that receive the minimum number of digits.</p> <p>The system routes calls with less than the minimum number of digits to treatment PDIL (partial dial).</p>
	DIGSIN	0 to 15	<p><i>Minimum number of incoming digits (case 1).</i> Enter the minimum number of incoming digits.</p> <p>If field PRERTSEL equals L, the entry in field DIGSIN must be a minimum of 3.</p>
	TYPCALL	DD, NL, NP, or OA	<p><i>Type of call (case 1).</i> Enter the type of call: DD (direct dial), NL (nil), NP (no prefix), or OA (operator assisted).</p>

**STDPRTCT.STDPRT selector Z** (continued)

## Field descriptions (Sheet 3 of 3)

Field	Subfield or refinement	Entry	Explanation and action
	NOPREDIG	0 to 7	<p><i>Number of prefix digits (case1).</i> Enter the number of digits interpreted as prefix digits.</p> <p>The switching unit can be for circle digit operation. When this event occurs, the number of prefix digits removed from the digit translation must include the circle digit.</p> <p>Examples of entries for a standard pretranslator for a local/toll switching unit for a circle digit operation are available. Refer to the description of table LENLINES, examples S and T for examples.</p>
	RTESEL	T, L or N	<p><i>Route selector (case1).</i> If translation routes to a table and index, enter data in refinement RTEID described as follows. Refinement RTEID contains subfields TABID and KEY.</p> <p><b>Note:</b> You cannot use this selector if pretranslator is assigned to Traffic Operator Position System (TOPS) and the type of calls DD (TYPCALL = DD).</p> <p>If translation routes to the directory number (DN) table, enter L and datafill refinements SNPA, NNX, and THOUDIG described as follows.</p> <p>Translation can route to table HNPACODE (national translations) or table CCTR (international translations). When this event occurs, enter N and datafill refinements TRANSYS and DIGSREGEN described as follows.</p>

**STDPRTCT.STDPRT selector Z** (continued)**RTESEL = T**

If the entry in field RTESEL is T, enter data into refinement RTEID.

Refinement RTEID appears in the following table.

**Field descriptions for conditional datafill**

Field	Subfield or refinement	Entry	Explanation and action
	RTEID	see subfields	<i>Route name.</i> This field contains subfields TABID and KEY.
	TABID	OFRT, IBNRTE, IBNRTE2, IBNRTE3, IBNRTE4, TOPSAMA, TOPS, RRTE, TTL4	<i>Table name (case1).</i> Enter the office route table name to which the system routes the translation.
	KEY	0 to 1023	<i>Index (case1).</i> Enter the index in the office route table to which the system routes the translation.

**RTESEL = L**

If the entry in field RTESEL is L, enter data into refinements SNPA, NNX, and THOUDIG. These refinements appear in the following table.

**Field descriptions for conditional datafill**

Field	Subfield or refinement	Entry	Explanation and action
	SNPA	numeric	<i>Serving numbering plan area (case1).</i> Enter the serving NPA to which the system assigns the terminating NNX.
	NNX	numeric (table of three digits)	<i>NNX code (case1).</i> Enter the NNX code to which the system assigns the called directory number.
	THOUDIG	0 to 9, B to F, or N	<i>Thousands digit (case1).</i> If field DIGSIN equals 3, enter the thousands digit of the subscriber number.  If field DIGSIN equals a minimum of 4, enter N.

**STDPRTCT.STDPRT selector Z** (continued)**RTESEL = N**

If the entry in field RTESEL is N, enter data into refinements TRANSYS and DIGSREGEN. These refinements appear in the following table.

**Field descriptions for conditional datafill**

Field	Subfield or refinement	Entry	Explanation and action
	TRANSYS	NO, NA, IN, or IP	<p><i>Translation system (case1).</i> Enter NA if translation is to route to national translations.</p> <p>Enter IN if translation is to route to international translations, local/toll switching unit only.</p> <p>Enter IP if translation is to route to international partitioned translations (DMS-250 only).</p>
	DIGSREGEN	numeric (a maximum of four digits)	<p><i>Digit regeneration (case1).</i> Enter the digits prefixed to the digits received. Enter these digits to generate the number required for digit analysis in the national or international translation.</p>

**For all route selector Z tuples**

For all route selector Z tuples, enter data into the following additional fields.

**Field descriptions (Sheet 1 of 2)**

Field	Subfield or refinement	Entry	Explanation and action
CONTMARK		+	<p><i>Continuation mark (case1).</i> Enter + to indicate that the next record contains additional information for this tuple.</p>
CASE2		see subfields	<p><i>Maximum digits received.</i> This field contains the following subfields: DIGSIN, TYPCALL, NOPREDIG, RTESEL, TABID, KEY, SNPA, NNX, THOUDIG, TRANSYS, and DIGSREGEN.</p> <p>The entries in the above subfields associate with calls that receive greater than the minimum number of digits. These calls receive less than or equal to the maximum number of digits.</p>

**STDPRTCT.STDPRT selector Z** (continued)

## Field descriptions (Sheet 2 of 2)

Field	Subfield or refinement	Entry	Explanation and action
	DIGSIN	0 to 18	<i>Maximum number of incoming digits (case2).</i> Enter the maximum number of incoming digits.
	TYPCALL	DD, NL, NP, or OA	<i>Type of call (case2).</i> Enter the type of call: DD (direct dial), NL (nil), NP (no prefix), or OA (operator assisted).
	NOPREDIG	0 to 7	<i>Number of prefix digits (case2).</i> Enter the number of digits the system interprets as prefix digits.
	RTESEL	T, L, or N	<p><i>Route selector (case2).</i> If translation routes to a table and index, enter T. Enter data into refinement RTEID described in the following. Refinement RTEID contains subfields TABID and KEY.</p> <p><b>Note:</b> You cannot use this selector if pretranslator is for Traffic Operator Position System (TOPS) and the type of call is DD (TYPCALL = DD).</p> <p>If translation routes to the directory number (DN) table, enter L. Enter data into refinements SNPA, NNX, and THOUDIG described as follows.</p> <p>The system can route to table HNPACODE (national translations) or table CCTR (international translations). When this event occurs, enter N. Enter data into refinements TRANSYS and DIGSREGEN like page described as follows.</p>

**STDPRTCT.STDPRT selector Z** (continued)**RTESEL = T**

If the entry in field RTESEL is T, enter data into refinement RTEID.  
Refinement RTEID appears in the following table.

**Field descriptions for conditional datafill**

Field	Subfield or refinement	Entry	Explanation and action
	RTEID	see subfields	<i>Route name.</i> This field contains subfields TABID and KEY.
	TABID	OFRT, IBNRTE, IBNRTE2, IBNRTE3, IBNRTE4, TOPS, RRTE, TTL4, TOPSAMA	<i>Table name (case 2).</i> Enter the office route to which the system routes the translation.
	KEY	0 to 1023	<i>Index (case2).</i> Enter the index in the office route table to which the system routes the translation.

**RTESEL = L**

If the entry in field RTESEL is L, enter data into refinements SNPA, NNX, and THOUDIG. These refinements appear in the following table.

**Field descriptions for conditional datafill**

Field	Subfield or refinement	Entry	Explanation and action
	SNPA	numeric	<i>Serving numbering plan area (case2).</i> Enter the serving NPA to which the assignment of the terminating NNX occurs.
	NNX	numeric	<i>NNX code (case2).</i> Enter the NNX code to which the assignment of the called directory number occurs.
	THOUDIG	0 to 9, B to F, or N	<i>Thousands digit (case2).</i> If field DIGSIN equals three, enter the thousands digit of the subscriber number.  If field DIGSIN equals a minimum of four, enter N.

**STDPRTCT.STDPRT selector Z (end)****RTESEL = N**

If the entry in field RTESEL is N, enter data into refinements TRANSYS and DIGSREGEN. These refinements appear in the following table.

**Field descriptions for conditional datafill**

Field	Subfield or refinement	Entry	Explanation and action
	TRANSYS	NO, NA, IN, or IP	<p><i>Translation system (case2).</i> Enter NA if the system routes translation to national translations.</p> <p>Enter IN if the system routes translation to international translations, local/toll switching unit only.</p> <p>Enter IP if the system routes translation to international partitioned translations (DMS-250 only).</p>
	DIGSREGEN	numeric (a maximum of four digits) or N	<p><i>Digit regeneration (case2).</i> Enter the digits prefixed to the digits received. Enter these digits to generate the number that is a requirement for digit analysis in the national or international translation. The digits the system regenerates are prefixed to the received digits separate from the number of digits received.</p>

**Datafill example**

Datafill for selector Z appears in example 15. See the "Datafill example" section in table STDPRTCT.STDPRT.

## STIDX

---

### Table name

Signaling Terminal Index Table

### Functional description

Table STIDX is necessary during a One Night Processes (ONP). Table STIDX makes sure that internal DMS software indexes are managed correctly for signaling terminal (ST) peripherals. Table STIDX also makes sure that internal DMS software indexes are managed correctly for other users of the ST\_DATA shared resource. Table STIDX makes sure that the system maintains Common Channel Signaling 6 (CCS6) and Common Channel Signaling 7 (CCS7) routesets during ONP.

Table STIDX is a read-only table. When you add or delete tuples in table STINV, the system automatically adds or deletes tuples in table STIDX.

### Datafill sequence and meaning

There is no requirement to datafill other tables before to table STIDX.

### Table size

The table size is 1024 tuples. You cannot increase or decrease the size of this table.

### Datafill

Datafill for table STIDX appears in the following table.

#### Field descriptions

Field	Subfield or refinement	Entry	Explanation and action
STNO		0 to 1023	<i>Signaling terminal number.</i> This field contains the ST number as entered in table STINV.
INTIDX		0 to 1023	<i>Internal descriptor index.</i> This field contains the internal descriptor index used by the ST into ST_DATA.

### Datafill example

Sample datafill for table STIDX appears in the following example.



**MAP example for table STIDX**

STNO	INTIDX
0	2
1	3
2	4
3	5
4	6
5	7
6	8
7	9
10	10
11	11
12	12
13	13
14	14
15	15
16	16
17	17

**Table history**  
**BCS36**

Table STIDX was introduced in BCS36.

## STINV

---

### Table name

Signaling Terminal Inventory (STINV) Table

### Functional description

Table STINV contains data for common channel signaling (CCS) terminals, signaling terminal controllers (STC), and the transmission link interface.

For junctored network (JNET) offices, parameter MAXNUCS in table OFCENG requires updates to allocate more memory. This condition occurs when table STINV is in use. For enhanced network (ENET) offices, set parameter MAXNUCS in table OFCENG to 0. Enter data in table STINV as required.

For related information, see table STPOOLS.

### Datafill sequence and meaning

You must enter data in the following tables before you enter data in table STINV.

- MSBINV
- MSBPINV

You must enter data in the following tables after you enter data in table STINV.

- C6LKSET
- C7LINK
- SPECCONN

*Note:* If signaling terminals (ST) are pooled, enter data in table STPOOLS before you enter data in table STINV.

### Table size

0 to 128 tuples

**STINV** (continued)**Datafill**

Datafill for table STINV appears in the following table.

**Field descriptions (Sheet 1 of 4)**

Field	Subfield or refinement	Entry	Explanation and action
STNO		0 to 1023	<i>Signaling terminal number.</i> Enter the signaling terminal number.
PMTYPE		ITAC, MSB6, MSB7, or TACC	<i>Peripheral module type.</i> Enter the peripheral module (PM) type as follows: <ul style="list-style-type: none"> <li>• Enter ITAC to specify international test access controller.</li> <li>• Enter MSB6 to specify CCIS6 signaling.</li> <li>• Enter MSB7 to specify CCS7 signaling.</li> <li>• Enter TACC to specify test access controller.</li> </ul> Any entry outside this range is invalid.
PMNO		0 to 127	<i>Peripheral module number.</i> Enter the PM number (defined in table MSBINV). Entries outside this range are not correct.
STCMNO		0 to 9	<i>Signaling terminal controller module number.</i> Enter the STC module number.
STCNO		0 to 7	<i>Signaling terminal controller circuit number.</i> Enter the STC circuit number in the specified module.
STCPEC		BX45AA 6X65AA 6X66AA 6X66AC	<i>Signaling terminal controller product engineering code.</i> Enter the product engineering code (PEC) of the STC card.  Enter BX45AA for the D-channel handler (DCH) terminal or the packet handler interface (PHI) signaling terminal
LOAD		alphanumeric (a maximum of eight characters)	<i>Load.</i> Enter the name of the STC software issue. For a list of available names, see the batch change supplement for the appropriate BCS. Enter the DCH or PHI loadfile name.

**STINV** (continued)**Field descriptions (Sheet 2 of 4)**

<b>Field</b>	<b>Subfield or refinement</b>	<b>Entry</b>	<b>Explanation and action</b>
HWCLASS		C6, C7, D, N6, or N7	<p><i>Hardware class.</i> Enter the designation of the common channel signaling (CCS) hardware type as follows:</p> <ul style="list-style-type: none"> <li>• C6 - Common Channel Interoffice Signaling No. 6 (CCIS6)</li> <li>• C7 - Common Channel Signaling 7 (CCS7)</li> <li>• D - Digital Private Network Signaling System (DPNSS)</li> <li>• N6 - CCITT no. 6 signaling</li> <li>• N7 - CCITT no. 7 signaling</li> </ul>
POOLNO		0 to 14 or N	<p><i>Signaling terminal pool number.</i> If the signaling ST belongs to a pool, enter the pool number. In other conditions, enter N (no).</p>
CONDATA		see subfields	<p><i>Connection data.</i> This field contains subfields CONTYPE, TMTYPE, TMNO, CCT, MICCARDCODE, PORT, CHNL, and BAUD.</p>

**STINV** (continued)

## Field descriptions (Sheet 3 of 4)

Field	Subfield or refinement	Entry	Explanation and action
	CONTYPE	DCON, MIC, MSB, or PRA	<p><i>Connection type.</i> Enter the peripheral side (P-side) connection type (transmission link connection information) as follows.</p> <p>If the STC connects directly to the transmission link, enter DCON. The system does not require any other datafill.</p> <p>If the signaling type is CCIS6 or N6 and a modem is a requirement, enter modem interface card (MIC). Enter data in fields TMTYPE, TMNO, CCT, and MICCARD CODE.</p> <p>If the signaling type is CCS7 or N7 and the STC switches through the network to the transmission link, enter message switch and buffer (MSB). Enter data in fields PORT, CHNL, and BAUD.</p> <p>Option primary rate access (PRA) is only for ISDN access controller (IAC) type PMs in table IACINV. This option differentiates a primary rate signaling terminal from a basic rate signaling terminal. This difference checks baud rate and DCH and PHI determination.</p>
	TMTYPE	T8A, TM2, TM4, or TM8	<p><i>Trunk module type.</i> If the entry in subfield CONTYPE is MIC, enter the type of trunk module (TM) with the MIC. In other conditions, leave this field blank.</p>
	TMNO	0 to 2047	<p><i>Trunk module number.</i> If the entry in subfield CONTYPE is MIC, enter the number assigned to the module with the MIC. In other conditions, leave this field blank.</p>
	CCT	0 to 29	<p><i>Trunk module circuit number.</i> If the entry in subfield CONTYPE is MIC, enter the TM circuit number with the MIC. In other conditions, leave this field blank.</p>
	MICCARD CODE	2X72AA 2X72AB 2X88AA	<p><i>Modem interface card code.</i> If the entry in subfield CONTYPE is MIC, enter the PEC of the MIC. In other conditions, leave this field blank.</p>

**STINV** (continued)

## Field descriptions (Sheet 4 of 4)

Field	Subfield or refinement	Entry	Explanation and action
	PORT	0 to 15	<i>C-side port.</i> If the entry in subfield CONTYPE is MSB, enter the C-side port to which the STC connects.
	CHNL	0 to 31	<i>C-side port channel.</i> If the entry in subfield CONTYPE is MSB, enter the C-side port channel number to which the STC connects. The position of the STC identifies the P-side port and channel of the DS30A data link.
	BAUD	0K, 48K, 56K, or 64K	<i>STC baud rate.</i> Enter the STC baud rate as follows: <ul style="list-style-type: none"> <li>• The entry in subfield CONTYPE can be MSB and the entry in field HWCLASS can be C7. In this event, enter a baud rate, in kilobits per second, of 48K, 56K, or 64K.</li> <li>• If the entry in subfield CONTYPE is MSB and the entry in field HWCLASS is C6, the STC uses analog signaling. Enter a baud rate of zero (0K).</li> <li>• If the entry in subfield CONTYPE is MSB and the entry in field HWCLASS is D, enter a baud rate of 64K.</li> </ul> <p>Entries outside this range are not correct.</p> <p><b>Note:</b> Error messages appear if you enter a baud rate that is not correct.</p>

**Datafill example**

Sample datafill for table STINV appears in the following example.

The following assignments appear in the example:

- assignments for MSB0 cross-connected to modules STC0 and STC1 on card slots 0, 1, 2, and 3. The P-side connection type is MIC, which indicates that four additional fields require data. The fields that require data are TMTYPE, TMNO, CCT and MICCARDCODE.
- assignments for MSB1 cross-connected to module STC0 on card slots 0, 1, 2, 3, and 4. Signaling terminals 42 and 43 belong to pools 0 and 2 in the

**STINV** (end)

sequence given. The P-side connection type is MIC. This connection type indicates that four additional fields require data. The fields that require data are TMTYPE, TMNO, CCT and MICCARDCODE.

- assignments for DCH and PHI (ISDN) in table STINV.

**MAP example for table STINV**

STNO	PMTYPE	PMNO	STCMNO	STCNO	STCPEC	LOAD	HWCLASS	POOLNO
0	MSB7	0	0	0	6X66AA	M7CQA01	C7	0
MSB 0 1	56K							
1	MSB7	0	0	1	6X66AA	M7CQA01	C7	0
MSB 0 2	56K							
2	MSB7	0	0	2	6X66AA	M7CQA01	C7	0
MSB 0 3	56K							
3	MSB7	0	0	3	6X66AA	M7CQA01	C7	0
MSB 0 4	56K							
4	MSB7	0	1	0	6X66AA	M7CQA01	C7	0
MSB 2 1	56K							
5	MSB7	0	1	1	6X66AA	M7CQA01	C7	0
MSB 2 2	56K							
6	MSB7	0	1	2	6X66AA	M7CQA01	C7	0
MSB 2 3	56K							
7	MSB7	0	1	3	6X66AA	M7CQA01	C7	0
MSB 2 4	56K							

## STN

---

### Table name

Special Tone Table

### Functional description

Tones that require trunk cards require table STN.

The following are the tones that appear in table STN:

- The NT3X68AC (call waiting tone generator card) generates expensive route warning tone (ERWT). The ERWT has code ERWT in table CLLI. The code is a fixed code. The ERWT consists of three 250-ms bursts of 440-Hz tone. The cadence is 250 ms on and 250 ms off. The cadence repeats three times.
- The NT3X68AC generates off-hook queuing tone (OHQT). The OHQT has pseudo code OHQT in table CLLI. The code is a fixed code. The OHQT is one 1 s burst of 440 Hz tone. The system applies the tone toward the calling party.
- The NT1X00AC (receiver off-hook tone card) generates receiver off-hook (ROH) tone generator. The ROH has code ROH in table CLLI. The code is a fixed code. The maximum number of simultaneous connections is 12 for each circuit.
- The NT1X80AA or NT1X80BA (EDRAM down loadable tone card) generates receiver off-hook (ROH) tone. This tone has tone samples downloaded from an external device, like a hard disk, tape, or sfdev. The ROH has code ROH in table CLLI. The code is a fixed code. The maximum number of simultaneous connections for each circuit is 12.
- The NT3X68AC generates tone generator call waiting (CWT). The CWT has code CWT in table CLLI. The code is a fixed code.
- The NT3X68AC generates Integrated Business Network (IBN) busy verification tone (BVTONE). The IBN BVTONE has the code BVTONE in table CLLI. The code is a fixed code. The remote switch requires BVTONE for network busy verification language (BVL). Enter a common language location identifier (CLLI) in table CLLI for the tone. Circuits in table STN must specify the location of the tone for the remote switch. The busy verification tone has a frequency of 440 Hz. The busy verification is 2 s of tone, followed by cycles of 15 s of silence and 500 ms of tone. This tone repeats while the attendant remains connected to a busy station. The system interrupts the conversation to insert the tone.

*Note:* The BVTONE no longer applies to the United Kingdom (UK) and Spanish offices.



---

**STN** (continued)

---

- The NT3X68BA generates international executive busy override tone (IEBOT). The IEBOT has the code IEBOT in table CLLI. The code is a fixed code. The NT3X68BA is a pre-empt, permanent signal, and conference tone generator card (U.K.). The tone is a 1340 Hz tone. The cadence is 0.2 s on and 2.0 s off.
- The NT3X68AC generates executive busy override tone (EBOT). The EBOT has the code EBOT in table CLLI. The code is a fixed code. The EBOT tone is 300 ms bursts of 440 Hz tone. The Directed Call Pickup—Barge in tone (feature BC0950) uses this tone.
- The NT3X68AA generates preset conference normal notification (PCNOR) tone. The NT3X68AA is a pre-empt, permanent signal, and conference tone generator card. The PCNOR tone has the code PCNOR in table CLLI. The code is a fixed code. The PCNOR tone is for routine originations of conference calls. The PCNOR tone alternates 852 Hz and 1336 Hz tones. These tones alternate at a rate of 300 ms for routine conferences. The notification tone continues until 2 s after all conferees answer or disconnect. This condition occurs after the conferees make a full complement of attempts at call completion. All switching units with the feature BC0708 (Preset Conference) require this tone.
- The NT3X68AC generates distinctive call waiting tone (DISTCWT). The DISTCWT has the code DISTCWT in table CLLI. The code is a fixed code. The DISTCWT informs the station if call waiting on is external or internal to the station customer group. If the waiting party is external to the busy station customer group, a two burst tone cadence separated by silence applies. Office parameter DIST\_CWT\_TONE in table OFCVAR specifies the length of the two bursts and the silence on the switch. This office parameter applies when feature BC1201 (Distinctive Call Waiting Tones) applies to the controller customer group. If the waiting call is internal to the customer group, the tone applied is a single burst. Office parameter CWT\_TONE\_LENGTH in table OFCVAR determines the length of the burst.
- The PEC NT3X68AC generates Teen Service call waiting tones. The Teen Service tones have the codes ENHCWT1, ENHCWT2, and ENHCWT3 in table CLLI. The codes are fixed codes. The Distinctive Call Waiting Tones distinguish the DN to which the system routes the incoming call when the line is busy. With the Teen Service feature, you can assign multiple DNs to a line without additional equipment. You can assign a maximum of three secondary directory numbers (SDN) and one primary directory number (PDN) to a line equipment number (LEN). Each DN assigned rings a separate pattern to identify the DN to which the system routes the call. When you use the Teen Service feature with the Enhanced Call Waiting feature, assignment of call waiting tones occurs. Assignment of

## STN (continued)

---

distinctive patterns to the tones occurs to differentiate the DN for which an incoming call waits.

Table STN lists the location and the maximum number of connections allowed for each of the above tones.

The maximum number of simultaneous connections for all tones in tables TONES and STN and announcements cannot exceed 80% of the number. This number is the number defined for parameter NUMCPWAKE in table OFCENG.

If the switching unit is local, or local and toll, assign an outgoing traffic separation number in field TRAFSNO to the tone. If the switching unit is not one of the preceding, assign 0 as the outgoing traffic separation number. If the switching unit has package NTX085AA (Traffic Separation Peg Count), the value range for the outgoing traffic separation numbers depends an office parameter value. This office parameter is TFAN\_OUT\_MAX\_NUMBER in table OFCENG. For switching units without software package NTX085AA, the range of values for the traffic separation numbers is 0 to 15. The outgoing traffic separation numbers 1 to 9 must be reserved for generic traffic separation numbers. See table TFANINT for the assignment of incoming to outgoing traffic separation numbers. With feature package NTX085BC, a peg count of all calls, by type of call, can accumulate. The types of calls are direct dial (DD), operator assisted (OA), or no prefix (NP). The calls accumulate between an originating source and an terminating destination. Incoming trunk or an originating line attribute are originating sources. Outgoing trunk, terminating line attribute, tone, or announcement are terminating destinations.

### **Circuit and slot number mapping for STM**

Correlation of the datafill in field TMNCKTNO to slot numbers appears in figure "Circuit and slot number mapping for STM". Refer to the *Peripheral Modules* for information on the STM layout.

**STN** (continued)

**Circuit and slot number mapping for STM**

Trunk circuit enables																							
00										29													
00										29													
NT2X70																							
NT4X65 CONTROLLER																							
TE 16	15	14	13	12	11	10	09	08	07	06	05	04	03	02	01	00							
TE 06	11 10 09 08 07 06																						
TE 06	17 16 15 14 13 12																						
TE 06	23 22 21 20 19 18																						
TE04	25 24 23 22																						
TE 06	29 28 27 26 25 24																						
TE04	29 28 27 26																						
NT4X65 CONTROLLER																							
TE 16	15	14	13	12	11	10	09	08	07	06	05	04	03	02	01	00							
TE 06	11 10 09 08 07 06																						
TE 06	17 16 15 14 13 12																						
TE 06	23 22 21 20 19 18																						
TE04	25 24 23 22																						
TE 06	29 28 27 26 25 24																						
NT0X50AA																							
NT2X70																							

Slot 01 02 03 04 05 06 07 08 09 10 11 12 13 14 15 16 17 18 19 20 21

The TE nn indicates the maximum trunk enables for each card slot, where nn is the number of enables.

**Datafill sequence and meaning**

You must enter data in table TMINV before you enter data in table STN.

To use ROH with the NT1X80AA or NT1X80BA cards, you must enter data in table DRAMS and EDRAMINV. You must enter data in table TMINV before you enter data in table STN.

**Table size**

The system automatically allocates memory for table STN.

**STN** (continued)**Datafill**

Datafill for table STN appears in the following table.

**Field descriptions (Sheet 1 of 2)**

<b>Field</b>	<b>Subfield or refinement</b>	<b>Entry</b>	<b>Explanation and action</b>
SK		see subfields	<i>Special tone key.</i> This field contains subfields TONE and MEMBER.
	TONE	alphanumeric (1 to 16 characters)	<i>Tone.</i> Enter the fixed code (TONE_INDEX) assigned to the tone trunk circuit in table CLLI.
	MEMBER	0 to 999	<i>Member number.</i> Enter the member number assigned to the tone trunk circuit.
TMTYPE		MMA, MTM, DTM or STM	<i>Trunk module type.</i> Enter the trunk module with this trunk circuit.
TMNO		0 to 255	<i>Trunk module number.</i> Enter the number assigned to the maintenance or service trunk module with the tone trunk circuit.
TMCKTNO		0to29 1 to 15 and 17 to 29	<i>Trunk module circuit number.</i> Enter the trunk module circuit number on the maintenance or service trunk module with the tone trunk circuit.  or  (DTM only). If the NT1X80AA or NT1X80BA card is in use, enter the trunk module circuit number on the DRAM trunk module (DTM) with the tone trunk circuit.
CARDCODE		alphanumeric (six characters)	<i>Card code.</i> Enter the product engineering code (PEC) of the tone trunk circuit.

**STN** (continued)**Field descriptions (Sheet 2 of 2)**

Field	Subfield or refinement	Entry	Explanation and action
MAXCONN		0 to 255	<i>Maximum connections.</i> Enter the maximum number of simultaneous connections allowed to the tone trunk circuit.
TRAFSNO		0 to 127	<i>Traffic separation number.</i> If the switching unit is local, or local and toll, enter the outgoing traffic separation number assigned to the tone. If the number is not a requirement, enter 0.

**Datafill example**

Sample datafill for table STN appears in the following example.

**MAP example for table STN**

```

TONE MEMBER TMTYPE TMNO TMCKTNO CARDCODE MAXCONN TRAFSNO
-----
ROH      1      MTM      2      18      1X00AC      12      0

```

**MAP example for table STN using NT1X80AA card**

```

TONE MEMBER TMTYPE TMNO TMCKTNO CARDCODE MAXCONN TRAFSNO
-----
ROH      2      DTM      2      18      1X80AA      12      0

```

**STN** (end)

---

**MAP example for table STN using NT1X80BA card**

STONE	MEMBER	TMTYPE	TMNO	TMCKTNO	CARDCODE	MAXCONN	TRAFSNO
ROH	3	DTM	3	18	1X80BA	12	0

**Table history**

**NA006**

Receiver off-hook (ROH) with NT1X80BA (EDRAM downloadable tone card) was added in NA006.

**CSP04**

Description of 1X80AA (EDRAM downloadable tone card) was added in CSP04. Notes were added to datafill sequence for ROH with the NT1X80AA card in CSP04. Field descriptions were added for fields TMTYPE and TMCKTNO in CSP04. Datafill example for table STN with the NT1X80AA card was added in CSP04.

**CSP02**

Descriptions of circuit and slot number mapping for STM were added in CSP02.

---

**STPOOLS**

---

**Table name**

Signaling Terminal Pools Table

**Functional description**

Table STPOOLS assigns common channel signaling (CCS) signaling terminals (STs) to pools. An ST pool is a collection of STs. This collection of STs share the common characteristics of signaling type and message switch and buffer (MSB) identifier. This condition allows any in-service member to be acceptable to signaling link management.

Withdraw and return pooled STs to the pool according to signaling link maintenance requirements.

All STs in a pool must be on the same MSB. In CCITT No.6 Signaling (N6), a routeset must be on the same MSB. Buffer retrieval requirements cause this position. One ST pool can supply a routeset.

Do not delete an ST pool from table STPOOLS if STs are in the pool.

Add each ST to table STINV with a non-null pool identification to make the ST a members of the pool. An ST can belong to only one pool.

See table STINV for related information.

**Datafill sequence and meaning**

You do not have to enter data in other tables before you enter data in table STPOOLS.

**Table size**

0 to 15 tuples

**STPOOLS** (continued)**Datafill**

Datafill for table STPOOLS appears in the following table.

**Field descriptions**

Field	Subfield or refinement	Entry	Explanation and action
STPOOLNO		0 to 14	<i>Signaling terminal pool number.</i> Enter the number of the pool.
PMTYPE		MSB6 or MSB7	<i>Peripheral module type.</i> Enter MSB6 for CCITT No.6 Signaling. Enter MSB7 for CCITT No.7 Signaling.  An entry outside the range indicated for this field is not correct.
PMNO		0 to 255	<i>Peripheral module number.</i> Enter the peripheral module number from table MSBINV.
HWCLASS		C6, C7, N6, N7, or D	<i>Hardware class.</i> Enter the designation for the common channel signaling hardware type: <ul style="list-style-type: none"> <li>• C6 (for Common Channel Interoffice Signaling No.6 [CCIS6])</li> <li>• C7 (for Common Channel Signaling No.7 [CCS7])</li> <li>• D (for Digital Private Network Signaling System [DPNSS])</li> <li>• N6 (for CCITT No.6 Signaling)</li> <li>• N7 (for CCITT No.7 Signaling)</li> </ul> An entry outside the range indicated for this field is not correct.

**Datafill example**

Sample datafill for table STPOOLS appears in the following example.

Two signaling terminal pools on PM1 for an MSB6 hardware type appear in the following example.



---

**STPOOLS** (end)

---

**MAP example for table STPOOLS**

STPOOLNO	PMTYPE	PMNO	HWCLASS
0	MSB6	1	N6
2	MSB6	1	N6

## STRATTRS

---

### Table name

Send\_To\_Resource Attributes Table

### Overview

The Send\_To\_Resource message is sent from the SCP to the SSP as a response to a query. The message instructs the SSP to interact with the calling party, using either the resources available on the SSP itself or by connecting the caller to an intelligent peripheral (IP), which uses its own resources for participant interactions. In either case, this interaction consists of playing an announcement to the caller and, optionally, collecting digits from the caller. The collected digits are reported back to the SCP in a Call\_Info\_From\_Resource message or a Resource\_Clear message.

The presence of the Destination Address parameter in the Send\_To\_Resource message determines if participant interactions should be performed by an IP. When the destination Address parameter is not present, the SSP processes the STR request using its internal resources, which consist of recorded announcements, tones, and digit receivers. When the Destination Address parameter is present, the caller is connected to an IP.

As a result of the implementation of this activity, the SCP specifies a set of Carriers to connect the originator to the IP, eliminating the need for an IP in every LATA.

### Functional description

Table STRATTRS provides Line Attributes for the translation of the Destination Address provided in the Send\_To\_Resource Interaction message.

This allows a Destination Address sent in the Send\_To\_Resource covertness message from SCP to be translated using Line Attributes provided in the new Table STRATTRS against that Destination Address. The table is traversed to find any entry corresponding to the particular Destination Address. If found, the triggering agent's attributes are overridden with the information available in the table. If no valid entry is found against the specified Destination Address, the triggering agent's attributes are used for translating the Destination Address.

### Datafill sequence and implications

Table STRATTRS must be datafilled in the following sequence.

- DESTINATION ADDRESS
- LINE ATTRIBUTE INDEX

**STRATTRS** (continued)

- XLAPLAN
- RATEAREA
- BILLING

**Table size**

The size of this table changes dynamically: The minimum is 0 tuples and the maximum depends on the number of IPs that can be configured.

Abbreviated table name	Minimum tuples	Maximum tuples	Information on memory
STRATTRS	0	Depending on the number of IPs that can be configured	The size of this table changes dynamically

**Datafill**

The next table lists datafill for table STRATTRS

**Field descriptions**

Field	Subfield	Entry	Explanation and action
KEY	NA	Directory number range	From digits. One to ten digit directory number. This is the start of the directory number range for the destination address.
			To digits. One to ten digit directory number. This is the end of the directory number range for the destination address.
LINEATTR	NA	alphanumeric (1-16 chars)	Line Attribute Index. Enter the line attribute index as defined in table LINEATTR.
XLAPLAN	NA	alphanumeric (1-16 chars)	Translations plan index. Enter the XLAPLAN line attributes index to identify the translations plan as defined in Table XLAPLAN.
RATEAREA	NA	alphanumeric (1-16)	Rate area index. Enter the RATEAREA line attributes index to identify the RATEAREA line attributes as defined in Table RATEAREA.
BILLING	NA	N, Y	Billing. Enter Y or N.

## STRATTRS (end)

---

*Note:* This tuple is used if the leading digits in the destination address returned by the SCP fall within the digit range specified.

### Datafill example

The next figure shows sample datafill for table STRATTRS.

#### MAP display example for table STRATTRS

```
>Table STRATTRS
>ADD
MACHINES NOT IN SYNC - DMOS NOT ALLOWED
JOURNAL FILE UNAVAILABLE - DMOS NOT ALLOWED
ENTER Y TO CONTINUE PROCESSING OR N TO QUIT
>Y
DESTADDR:
>4164671001 4164671999
LINEATTR:
>413
XLAPLAN:
>416_P621_418
>RATEAREA:
>L416_LATA1_400
>BILLING:
>Y
TUPLE TO BE ADDED:
4164671001 4164671999 413 416_P621_418 L416_LATA1_400 Y
ENTER Y TO CONFIRM, N TO REJECT OR E TO EDIT.
>Y
TUPLE ADDED
```

### Release history

#### NA017

In accordance with CSR Q00412851 table STRATTRS is modified. Field Destination is renamed to Key. Field Key consists of a directory number range.

A new table STRATTRS is introduced by feature 59028643 that provides Line Attributes for the translation of Destination Address proved in the Send\_To\_Resource Interaction message.

## STREAM

---

### Table name

Stream Table

### Functional description

The purpose of the remote operation service is to provide an interface for the communication of remote operations (RO) between applications. These applications are in DMS and external systems like the network operations system (NOS). The applications that require the interface to function are:

- file transfer (FT)
- centralized MAP (CMAP)
- dynamically controlled routing (DCR)
- the network operations protocol (NOP) MAP level

The addition of Table STREAM permits the DMS user to define the correlation of PROTOCOL ID to STREAM NAME. The STREAM NAME is on the dynamic network controller (DNC). This definition occurs on the DMS. The FT uses the DNC. The DNC is the equipment located at the premises of the customer that collects data from the DMS. Table STREAM allows the operation of two data transfer systems, XFER and FT, at the same time.

The correlation defined on the FT DNC appears in Table STREAM. This correlation is an image of the same data the DNC contains. Use the DEFINE command to define the correlation found on the XFER DNC. When FT requests a specified PROTOCOL ID, the FT software on the DMS searches through the STREAM table. The FT software performs this action to find the corresponding STREAM NAME. The FT software uses the STREAM NAME to specify to Device Independent Recording Package (DIRP) the stream the FT DNC receives. The use of the two transfer systems occurs without conflict. The exception is that the reception of the same stream at the same time does not occur.

### Table size

24 tuples

**STREAM** (end)**Datafill**

Datafill for table STREAM appears in the following table.

**Field descriptions**

Field	Subfield or refinement	Entry	Explanation and action
INDEX		0 to 23	<i>Index.</i> Enter the PROTOCOL ID of the stream on the DNC.
STREAM		SMDR, KT, ATT, TTRF, OM	<i>Stream name.</i> Enter one to four characters to represent the STREAM NAME that corresponds to the PROTOCOL ID entered in the INDEX field. Use any of the entries that appear or use a new entry. In either example, the PROTOCOL ID and STREAM NAME must be the same in the DNC as in table STREAM.

**Datafill example**

Sample datafill for table STREAM appears in the following example.

**MAP example for table STREAM**

INDEX	STREAM
1	SMDR
2	OM

## STSTONET-Canada only

### Table name

Serving Translation Scheme Table

### Functional description

Table STSTONET provides a mapping between a serving translation scheme (STS) and network information (NETINFO) parameter fields.

### Datafill sequence and meaning

Enter the following tables before you enter table STSTONET-Canada only.

- HNPACONT
- NETNAMES

### Table size

0 to 1000 tuples

### Datafill

Datafill for table STSTONET-Canada only appears in the following table.

### Field descriptions

Field	Subfield or refinement	Entry	Explanation and action
STS		000 to 999	<i>Serving translation scheme.</i> Enter the STS number data you enter in table HNPACONT.
NETNAME		alphanumeric (1 to 32 characters)	<i>Network name.</i> Enter the network name data you enter in table NETNAMES to identify an external network identification (ID).
NETCGID		1 to 4096	<i>Network customer group identification.</i> Enter the predefined number that identifies an external customer group on a Meridian SL-100.  An entry of 0 is not correct.
NCOS		0 to 511	<i>Network class of service.</i> Enter the network class of service (NCOS).

---

**STSTONET-Canada only** (end)

---

**Datafill example**

Sample datafill for table STSTONET-Canada only appears in the following example.

In the example, the following values appear:

- the network name is NETWKD
- the ID is 100
- the NCOS is 60
- the STS is 600

**MAP example for table STSTONET-Canada only**

STS	NETWKD	NETCGID	NCOS
600	NETWKD	100	60



## SUBGRP

---

### Table name

Attendant Subgroup Table

### Functional description

The attendant subgroup table SUBGRP is required in a switching unit equipped with the Integrated Business Network (IBN) feature.

One entry is required in this table for each customer group that has field CONSOLES set to Y (yes) in table CUSTENG and has an entry in table CUSTCONS.

A customer can have a number of locations within a city served by the same switching unit. The customer can centralize attendant service on a full-time or part-time basis for these locations. To permit centralization of attendants, on a part-time basis, each of the attendant consoles is assigned to subgroups. The switching unit supports a maximum of eight subgroups for each customer group. During regular hours, attendant type calls are directed to the appropriate attendant subgroup.

Subgroup 0 is always the controlling subgroup.

If a customer does not require decentralization operation, all attendant consoles for the customer group belong to subgroup 0.

All new call arrivals, including recalls to the attendant consoles in the subgroup, are placed in the call queue in the order of their arrival. While queued, audible ringback tone is provided to the caller by the switching unit, except where ringing is provided by the originating office. Audible ringing is provided until the call is answered or abandoned.

The length of the queue can be limited based on the maximum permissible time that a call can wait in the queue. Calls that exceed the estimated time threshold are routed to either busy tone or announcement. The diversion threshold can range from 4 s to 17 min in 4-s increments. It can be specified as infinite, in which case it is set to 0 s.

This threshold is specified in field CQDIVTHR.

The maximum number of calls allowed in a particular subgroups queue is calculated once every 100 s using the following formula:

$$\text{NCALLQ} = \text{NCONS} \times (\text{DIVTRS} / \text{DAST})$$

---

**SUBGRP** (continued)

---

*where*

**NCALLQ**

is the number of calls allowed in queue

**NCONS**

is the the number of available consoles

**DIVTRS**

is the divert threshold

**DAST**

is the weighted average service time

The weighted average service time is also calculated every 100 s as follows. A running total of the service time of each call answered during the 100 s is divided by the total number of calls answered during this period to give an average service time for this 100-s period. The new weighted average service time is equal to 0.75 of the current weighted average plus 0.25 of the average just determined for this 100-s period. This weighted average is initialized to 16 s. If during any 100-s interval no calls were answered and the queue of calls is empty, the weighted average is set to its initial value.

The preceding only applies if the customer has not specified the divert threshold as being infinite.

The call waiting lamp flashes when calls are waiting in the queue for a time equal to or greater than a specified threshold and there is a change in the queue status. The queue status change can include a call entering or a call leaving the queue. The threshold can range from 4 s to 17 min in 4-s intervals. It can also be specified as infinite, in which case it is set to 0 s.

This threshold is specified in field CQFLTHR.

All stations belonging to a subgroup must have the same number of digits in the extension number.

If the number of digits received from an attendant is less than the value of field MINDIGSR, the time-out is 5 s. If it is greater than the value of field MINDIGSR, the time-out is 0.5 s. The recommended value for field MINDIGSR is the value of STNEXTLN.

The serving numbering plan area (NPA) and directory number assigned to the subgroup for billing purposes must be assigned as a directory number in the switching unit.

## **SUBGRP** (continued)

---

The option EMALTONE can be assigned to the subgroup, if an audible tone is provided to alert the attendant to an emergency enqueued call.

The option FORCING can be assigned to a subgroup so that calls are automatically presented to idle attendant consoles without pressing any loop key.

The forcing option is used to speed up the processing of incoming calls to attendant consoles (AC). Calls are answered without pressing a loop key when an AC has all loops idle and there are calls waiting in the subgroup queue for that console.

Currently, an AC is alerted with either buzzing or tone, or both when presented with a call. The attendant must then press the loop key on which the call was presented, or an incoming call identifier (ICI) key if the call has an ICI associated with it, to answer the call.

This feature eliminates the need for the attendant to press a loop or ICI key when answering calls when their console is idle. When call forcing is active and the AC is presented with a call, the attendant hears the normal buzzing or tone or both from the AC. During this alert, the source lamp associated with the loop key where the call is being presented flashes, and if there are calls waiting in any of the ICI queues, the associated ICI key lamps are turned on as well. This scenario is the same for any console, regardless of whether or not the option FORCING is assigned to the consoles subgroup. When the alerting is completed, the call is automatically answered, the lamp is turned on, and the attendant is able to talk with the caller. This is the operational portion of the AC Call Forcing feature.

### **Datafill sequence and implications**

If the Partitioned Table Editor feature is in the switch load, the ownership of each tuple in this table is defined in tables DATAOWNR and OWNTAB.

The entries in table DATAOWNR that apply to this table are those with field TABNAME equal to CUSTGRP and field CUSTNAME equal to the value of field CUSTGRP in this table.

The entry in table OWNTAB that applies to this table is the one with field TABNAME equal to SUBGRP.

### **Table size**

Memory is automatically allocated and is equal to the sum total of option SGRPNUM in table CUSTCONS.

**SUBGRP** (continued)**Datafill**

The following table lists datafill for table SUBGRP.

**Field descriptions (Sheet 1 of 2)**

Field	Subfield or refinement	Entry	Explanation and action
SGRPKEY		see subfields	<i>Subgroup key</i> This field consists of subfields CUSTGRP and SUBGRPNO.
	CUSTGRP	alphanumeric (1 to 16 characters)	<i>Customer group name</i> Enter the name assigned to the customer group.
	SUBGRPNO	0 to 7	<i>Subgroup number</i> Enter the subgroup number.
SNPADN		see subfields	<i>Serving NPA and directory number</i> This field consists of subfields SNPA and DN.
	SNPA	numeric	<i>Serving numbering plan area</i> Enter the serving NPA which is assigned to the subgroup for billing purposes.
	DN	numeric0 to 9 (1 to 7 characters)	<i>Directory number</i> Enter the directory number assigned to the subgroup for billing purposes.
CQOVTRMT		0 to 63	<i>Call queue overflow treatment</i> Enter the treatment number assigned in table IBNTREAT to which all calls to the attendant are routed when all the attendant queue registers are busy.
CQFLTHR		0 to 255	<i>Call waiting flash threshold</i> Enter the calls waiting flash threshold in 4-s increments (for example, a value of 3 specifies an interval of 12 s). The threshold can be specified as infinite in which case it is set to 0 (zero).

**SUBGRP** (continued)

## Field descriptions (Sheet 2 of 2)

Field	Subfield or refinement	Entry	Explanation and action
CQDIVTHR		0 to 255	<i>Queue length threshold</i> Enter the diversion threshold in 4-s increments (for example, a value of four specifies an interval of 16 s. The threshold can be specified as infinite in which case it is set to 0 (zero).
STNEXTLN		1 to 7	<i>Station extension length</i> Enter the number of digits in the extension numbers assigned to the subgroup.
MINDIGSR		1 to 7	<i>Minimum digits received</i> Enter the minimum number of digits that can be dialed by the attendants assigned to the subgroup.
OPTIONS		EMALTONE FORCING QSTATUS or blank	<i>Options</i> If subgroup has the emergency alerting tone option, enter EMALTONE. If subgroup has the forcing option, enter FORCING. If subgroup has the attendant console call queue status option, enter QSTATUS. Otherwise, leave blank.

**OPTIONS = QSTATUS**

If the entry in field OPTIONS is QSTATUS, datafill refinements FLSDGRP, FLSDPT, MAXSDGRP, MAXSPT, and CQMAXTHR as described below.

## Field descriptions for conditional datafill (Sheet 1 of 2)

Field	Subfield or refinement	Entry	Explanation and action
	FLSDGRP	0 to 511	<i>Flash signal distribution point group</i> Enter the signal distribution (SD) group number for the call queue flash threshold SD point.
	FLSDPT	0 to 6	<i>Flash signal distribution point</i> Enter the SD point number of the call queue flash threshold SD point.

**SUBGRP** (continued)**Field descriptions for conditional datafill (Sheet 2 of 2)**

<b>Field</b>	<b>Subfield or refinement</b>	<b>Entry</b>	<b>Explanation and action</b>
	MAXSDGRP	0 to 511	<i>Maximum calls threshold signal distribution point group</i> Enter the SD group number of the call queue maximum calls threshold point.
	MAXSDPT	1 to 6	<i>Maximum calls threshold signal distribution point</i> Enter the SD point number of the call queue maximum calls threshold SD point. Any entry outside of this range is invalid.
	CQMAXTHR	0 to 4095	<i>Call queue maximum calls threshold</i> Enter the maximum number of calls in the subgroup call queue. When this value is met or exceeded, the SD points defined by fields MAXSDGRP and MAXSDPT are activated.

**Datafill example**

The following example shows sample datafill for table SUBGRP.

The example is for subgroup 1 of customer group BNRMC.

The SNPA and directory number for billing purposes is 613 226 5400.

If all attendant queue registers are busy, calls to the attendant are routed to treatment number 7 in the table IBNTREAT.

The flash and diversion thresholds are 20 and 24 s respectively.

The number of digits in the station extension, and the minimum number of digits received from the attendant is 5.

The option EMALTONE is assigned.

## SUBGRP (end)

---

### MAP display example for table SUBGRP

SGRPKEY	SNPADN	CQOVTRMT	CQFLTHR	CQDIVTHR	STNEXTLN
MINDIGSR					OPTIONS
BNRMC 0	613 2265400	7	5	6	5
5					EMALSTONE \$

**SUBPROT****Table name**

Subtable Protection Table

**Functional description**

This table is optional and is only required if one or more of the subtables listed in the following table requires a different set of command classes than its control table.

**List of subtables and their control tables**

<b>Subtable</b>	<b>Control table</b>
ATTRIB	HNPACONT
FNPACODE	FNPACONT
FNPASTS	FNPACONT
HNPACODE	HNPACONT
RTEREF	FNPACONT
RTEREF	HNPACONT

Table SUBPROT defines command classes for users able to read, change, add, or delete tuples for each subtable that requires one or more different command classes than the command classes assigned to the control table.

The protection levels for the control tables are defined in table CUSTPROT.

Datafill for table CUSTPROT is automatically produced by table control and is maintained unless changed by the operating company. The initial values produced by table control for the privilege classes are 15.

The privilege class that has the read-protect capability is allowed to read but not allowed to update, add, or delete tuples from the subtable.

The privilege class that has the update-protection capability is allowed to read and update, but not allowed to add or delete tuples from the subtable.

The privilege class that has the all-protection capability, is allowed to read, update, add, or delete tuples from the subtable.

If the switch has the partitioned table editor feature, non-operating company users should only be allowed to use the subtables that have their control tables



**SUBPROT** (continued)

datafilled in table OWNTAB. The privilege classes assigned to tables that are not datafilled in table OWNTAB should not be assigned to non-operating company users.

New data can be created for subtables FNPASTS by adding new tuples to them, therefore these subtables should either be *read only* or *update only* for non-operating company users.

To change this table, the operating company must load the module ENGWRITE from the non-resident tape and enter command ENGWRITE ON.

For the initial input, the operating company shall only provide input for those subtables that have one or more of the privilege classes with a value other than specified for its control table.

**Datafill sequence and implications**

There is no requirement to datafill other tables prior to table SUBPROT.

**Table size**

0 to 16 tuples

**Datafill**

The following table lists datafill for table SUBPROT.

**Field descriptions (Sheet 1 of 2)**

Field	Subfield or refinement	Entry	Explanation and action
TABNAME		see subfields	<i>Table name</i> This field consists of subfields TABNAME and SUBNAME.
	TABNAME	FNPACONT or HNPACONT	<i>Control table name</i> Enter the control table name FNPACONT or HNPACONT.
	SUBNAME	ATTRIB FNPACODE FNPASTS HNPACODE or RTEREF	<i>Subtable name</i> Enter the subtable name.

**SUBPROT** (end)**Field descriptions (Sheet 2 of 2)**

Field	Subfield or refinement	Entry	Explanation and action
READPROT		0 to 30	<i>Read protect</i> Enter the privilege class that is allowed to read this subtable.
UPDTPROT		0 to 30	<i>Update protection</i> Enter the privilege class that is allowed to read this subtable and update tuples.
ALLPROT		0 to 30	<i>All protection</i> Enter the privilege class that is allowed to read, update, add, or delete tuples from this subtable.

**Datafill example**

The following example shows sample datafill for table SUBPROT.

The FNPACODE subtables are assigned privilege classes of 10. The privilege classes assigned to their control table (FNPACONT) are 15.

**MAP display example for table SUBPROT**

TABNAME		READPROT	UPDTPROT	ALLPROT
FNPACONT	FNPACODE	10	10	15

**SUPERTKG****Table name**

Super Trunk Group

**Functional description**

Table SUPERTKG associates up to 220 trunk groups together, which allows calls to be distributed evenly across the trunk groups.

**Datafill sequence and meaning**

Enter data into table TRKGRP before table SUPERTKG. When a new tuple is written/deleted in/from table SUPERTKG, it is also written/deleted in/from table RTETRK.

**Table size**

0 to 255 tuples

**Datafill**

The table that follows lists datafill for table SUPERTKG.

**Field descriptions**

Field	Subfield	Entry	Explanation and action
SGNAME		1 to 16 alphanumeric	This is the routing selector and is the key field for this table. Enter the super-group name.
TRKGRPS		1 to 16 alphanumeric	Enter 1 to 220 trunk group names from those defined in table TRKGRP.

**Datafill example**

The following example shows sample datafill for table SUPERTKG.

**MAP display example for table SUPERTKG**

SGNAME	TRKGRPS
ISP4GRP1	(IPS4TRK1) (ISP4TRK2) (ISP4TRK3) \$
ISP4GRP2	(ISP4TR31) (ISP4TR32) (ISP4TR33) (ISP4TR60) \$

## **SUPERTKG** (end)

---

### **Table history**

#### **MMP16**

Change to Datafill sequence and meaning, and field description for field TRKGRPS for feature 59027945 (SUPERTKG - RTETRK Table Control Interactions).

#### **EUR008**

Table introduced.

## **SUR** (continued)

---

### **CEP dialing plan**

The dialing plan for the Caribbean islands is based on the North American plan (NPA-NXX-XXXX). The islands have NPA 809, with each island having one or more unique NXX associated with it.

### **CEP ITOPS rating zones**

The following terminology is used within this document to define the different CEP ITOPS rating zones:

- local calls completed within the same rate zone as the calling customer (calls within the same NXX are always considered to be in the local rate zone)
- domestic calls completed within numbering plan area (NPA) 809 but to an NXX in a different rate zone as the calling customer
- North American calls completed from NPA 809 to any destination based on the NPA-NXX dialing plan (other than domestic calls)
- International (or overseas) calls completed from NPA 809 to a foreign country not based on the NPA-NXX dialing plan (outside World Zone 1)

### **CEP surcharges**

Surcharges can be applied on the following types of call:

- station collect billing
- station third number billing
- station time and charges
- station calling card billing
- person collect billing
- person third number billing
- person time and charges
- person calling card billing

Surcharges are associated with the rate schedule. A field exists for each of the possible surcharges and the fields follow the order shown above. Surcharges can vary from 0 to 255.

## **Datafill sequence and implications**

Table SCHED must be datafilled before table SUR.

## **Table size**

0 to 256 tuples

**SUR** (continued)**Datafill**

The following table lists datafill for table SUR.

**Field descriptions**

<b>Field</b>	<b>Subfield or refinement</b>	<b>Entry</b>	<b>Explanation and action</b>
SCHNAME		alphanumeric (1 to 16 characters)	Schedule name. Enter the schedule name as previously datafilled in table SCHED.
SCOL		0 to 255	Surcharge on station collect calls. Enter the amount of surcharge in cents that applies to station collect calls.
STHR		0 to 255	Surcharge on station calls billed to a third number. Enter the amount of surcharge in cents that applies to station calls billed to a third number.
STC		0 to 255	Surcharge on station time and charge calls. Enter the amount of surcharge in cents that applies to station calls when time and charges are requested.
SCC		0 to 255	Surcharge on station calls billed to a credit card. Enter the amount of surcharge in cents that applies to station calls billed to a credit card number.
PCOL		0 to 255	Surcharge on person collect calls. Enter the amount of surcharge in cents that applies to person collect calls.
PTHR		0 to 255	Surcharge on person calls billed to a third number. Enter the amount of surcharge in cents that applies to person calls billed to a third number.
PTC		0 to 255	Surcharge on person time and charge calls. Enter the amount of surcharge in cents that applies to person calls when time and charges are requested.
PCC		0 to 255	Surcharge on person calls billed to a credit card. Enter the amount of surcharge in cents that applies to person calls billed to a credit card number.

## **SUR** (end)

---

### **Datafill example**

The following examples show sample datafill for table SUR.

The first example shows datafill for the North American TOPS.

#### **MAP display example for table SUR**

SCHNAME	SCOL	STHR	STC	SCC	PCOL	PTHR	PTC	PCC
TELENORAM	0	0	25	0	0	0	25	0

The second example shows datafill for the CEP ITOPS.

#### **MAP display example for table SUR**

SCHNAME	SCOL	STHR	STC	SCC	PCOL	PTHR	PTC	PCC
STKITTS465	0	0	20	0	0	0	20	0

---

**SURI**

---

**Table name**

TOPS Surcharge Inactive Table

**Functional description**

Feature V0178 (TOPS Mass Table Control) permits data changes in table SUR to be mass-table-controlled. In other words, the feature permits the simultaneous activation of data changes in the table by entering the data changes for the table into table SURI, and then, when all the required changes are entered, swap the contents of table SUR with table SURI.

For further information on feature V0178, refer to table CHARGEI.

Refer to table SUR.

**Datafill sequence and implications**

Refer to table SUR.

**Table size**

Refer to table SUR.

**Datafill**

Refer to table SUR.

**Datafill example**

Refer to table SUR.



---

**SUSHELF**

---

**Table name**

Service Unit Shelf Table

**Functional description**

For related information, refer to table LIUINV.

Table SUSHELF inventories the frame transport bus (F-bus) components of the link interface shelf (LIS). A LIS can be supported by a transaction bus (T-bus) and F-bus interface (TFI) card on either a link peripheral processor (LPP), an enhanced LPP (ELPP), or a DMS-bus, or by a LIS F-bus controller (LFC) on the LIS if it is connected as a stand-alone LIS to subrate DS512 (SR512) fiber links of a DMS-bus. TFI-supported F-buses on an LPP, an ELPP, or a DMS-bus consist of three LISs for an LPP and an ELPP or two LISs for a DMS-bus. A DMS-bus can support up to two stand-alone LISs.

**Datafill information**

The following information must be taken into consideration when using table SUSHELF:

- The interface card and the port allocation must be symmetric.
  - Note:* Stand-alone LIS F-buses can be datafilled on NT9X17 cards with different link numbers (NUMLINKS) if the port number identified is compatible for links on both NT9X17 cards.
- Both F-buses of an LPP, ELPP, or message switch (MS) must be offline when their related entries in table SUSHELF are deleted.
- When changing table SUSHELF, busy one F-bus, and then change the table for that half-shelf. Once the changes are made, return the F-bus to service. Then busy the second F-bus, make the required changes, and return the second F-bus to service. Using this method eliminates the need for an LPP, ELPP, or DMS-bus outage.
- No link interface unit (LIU) can be datafilled in table LIUINV on a shelf that is being deleted by table SUSHELF.
- No network interface unit (NIU) can be datafilled in table NIUINV on a shelf that is being deleted by table SUSHELF.
- LIU shelf product engineering codes (PEC) and card PECs must be compatible with the supporting interface card (NT9X73, LMS F-bus rate adapter card, or NT9X17AA, NT9X17AC, or NT9X17AD message switch four-port cards, or NT9X17BB or NT9X17DA DMS-bus 64-port cards).

## SUSHELF (continued)

- The physical location of a LIS supported by a TFI card must have the same cabinet location as the host LPP, ELPP, or DMS-bus. This is not a requirement for a stand-alone LIS supported by a DMS-bus.
- Variable shelf configurations must have the appropriate TFI F-bus terminations engineered.
- LIU shelves equipped with NT9X74BA/CA F-bus repeater cards or NT9X96AA LIS F-bus controller cards must have the correct NTEX20 intrashelf termination paddle board terminations datafilled.

### Datafill sequence and implications

The following tables must be datafilled before table SUSHELF:

- LIMINV
- LIMCDINV
- MSCDINV

Tables LIUINV and NIUINV must be datafilled after table SUSHELF.

### Table size

0 to 55 tuples

The requirement is determined by multiplying the maximum number of F-bus controllers ( $\text{max\_lims} + 1$  [for DMS-bus] = 18) by the maximum number of LIU shelves ( $\text{max\_number\_liu\_shelves} = 3$ ).

### Datafill

The following table lists datafill for table SUSHELF.

#### Field descriptions

Field	Subfield or refinement	Entry	Explanation and action
SHELFKEY		see subfields	<i>Shelf key</i> This field consists of subfields CONTROL, CTRLNUM, CARDNUM, PORTNUM, and LIUSHELF.
	CONTROL	LIM or MS	<i>Control</i> Enter LIM to specify that the LIM is the controlling entity. Enter MS to specify that the message switch (MS) is the controlling entity.

**SUSHELF** (continued)**Field descriptions**

<b>Field</b>	<b>Subfield or refinement</b>	<b>Entry</b>	<b>Explanation and action</b>
	CTRLNUM	0 to 16or NIL	<p><i>Control number</i></p> <p>Enter the control number for the LIM.</p> <p><b>Note:</b> The specified LIM must already be datafilled in table LIMINV.</p> <p>Enter NIL if the MS is the controlling entity.</p>
	CARDNUM	5 to 23	<p><i>Card number</i></p> <p>Enter the interface card number on the MS or the LIS. This entry identifies the interface card pair and must be a TFI card or an NT9X62BA (four-port subrate DS512 paddle board) that supports the subrate DS512 (SR512) message links.</p> <p>The only valid entry for a TFI card supporting single F-bus configuration is 12.</p> <p>The only valid entries for a TFI card supporting triple F-bus configuration are 7 (for LIS 1), 8 (for LIS 2), and 9 (for LIS 3). These entries correspond to slots datafilled in table LIMCDINV for triple F-bus configuration.</p> <p>Card allocation must be symmetric.</p>
	PORTNUM	0 to 3	<p><i>Port number on card</i></p> <p>Enter a value that identifies the port on the interface card. Port allocation is symmetric.</p> <p>The only valid entry for ports on TFI cards is 0 (zero).</p> <p>Port numbers are validated against the front card and number of fiber links supported for ports on SR512 cards.</p>

**SUSHELF** (continued)**Field descriptions**

<b>Field</b>	<b>Subfield or refinement</b>	<b>Entry</b>	<b>Explanation and action</b>
	LIUSHELF	0 to 3	<p><i>Link interface unit shelf</i></p> <p>Enter the shelf number identifying the LIU shelf. Each cabinet contains a possible four shelves. This shelf number must be the shelf address within the frame.</p> <p>Enter 1 to 3 for LIU shelves with an LPP or an ELPP.</p> <p>Enter 1 to 2 for LIU shelves with an MS SuperNode SE TFI, regardless of the position within the SCC frame.</p> <p>Enter 1 for all LIU shelves with an MS LFC (fiber LIS) regardless of the position within the EMC frame.</p> <p>Any entry outside the range indicated for this field is invalid.</p>
FLOOR		0 to 99	<p><i>Floor</i></p> <p>Enter the floor on which the cabinet resides.</p>
ROW		A to Z AA to ZZ (except I, O, II, OO)	<p><i>Row</i></p> <p>Enter the row on the floor in which the cabinet resides, with the exception of I, O, II, and OO. The row numbers are shown on the frame.</p>
FRAMEPOS		0 to 99	<p><i>Frame</i></p> <p>Enter the position of the LIS cabinet in the row.</p>
FRAMETYP		EMC, LIM, or SCC	<p><i>Frame type</i></p> <p>Enter the frame type of the LIS cabinet.</p> <p>Enter EMC for the MS LFC (fiber LIS) interface type cabinet.</p> <p>Enter LIM for the LPP or ELPP cabinet.</p> <p>Enter SCC for the SuperNode SE TFI interface type cabinet.</p> <p>Any entry outside the range of indicated values for this field is invalid.</p>

**SUSHELF** (continued)**Field descriptions**

<b>Field</b>	<b>Subfield or refinement</b>	<b>Entry</b>	<b>Explanation and action</b>
FRAMENUM		0 to 511	<i>Frame number</i> Enter the number of the frame.
SHELFPOS		0 to 77	<i>Shelf position</i> Enter the base mounting position of the shelf. Standard base mounting positions are 0 (zero), 13, 26, and 39. For LIU shelves, enter 0 (zero) to 3.
SHELFPEC		NT9X72AA NT9X72BA NT9X72CA NT9X0810 orNT9X7204	<i>Shelf product engineering code</i> Enter the PEC of the shelf. This PEC identifies the maximum number of LIUs on the shelf.  <b>Note 1:</b> All LIU shelves belonging to the same controller must have the same shelf PEC.  <b>Note 2:</b> The NT9X72BA LIU shelf cannot be supported by an NT9X73AA TFI card. Any entry outside the range indicated for this field is invalid.
CONTMARK		+ or \$	<i>Continuation mark</i> Enter + if additional information for this tuple is contained in the next record. Otherwise, enter \$ to indicate the end of the tuple.
CARDINFO		see subfields	<i>Card information</i> This field consists of subfields SLOT, FRONTPEC, and BACKPEC. It contains information on the cards for F-bus 0 and F-bus 1 on the LIS. Data is required for at least one card for each F-bus.  All cards for F-bus 0 must be entered before F-bus 1 cards are entered.

**SUSHELF** (continued)**Field descriptions**

<b>Field</b>	<b>Subfield or refinement</b>	<b>Entry</b>	<b>Explanation and action</b>
	SLOT	1, 4, 7 to 33, or 36	<p><i>Slot</i></p> <p>Enter the slot number of the card on the LIS.</p> <p>Enter 1 or 4 for power converter cards on F-bus 0.</p> <p>Enter 7 for required F-bus 0 card.</p> <p>For optional F-bus 0 termination on an NT9X72AA shelf, enter 31. Otherwise, enter 30.</p> <p>Enter 32 for required F-bus 1 card.</p> <p>For optional F-bus 1 termination on an NT9X72AA shelf, enter 8. Otherwise, enter 10.</p> <p>Enter 33 or 36 for power converter cards on F-bus 1.</p> <p>These slot numbers are corrected as required by table control.</p>
	FRONTPEC	NTDX16AA NT9X19EA NT9X30AA NT9X30AC NT9X31AA NT9X74AA NT9X74BA NT9X74CA NT9X74DA NT9X96AA orNIL	<p><i>Front card product engineering code</i></p> <p>Enter the PEC of the front card.</p> <p>For power converter cards, enter DX16AA, NT9X30AA, NT9X30AC, or NT9X31AA.</p> <p>For TFI-supported LIS only, enter NT9X74AA, NT9X74BA, NT9X74CA, or NT9X74DA (F-bus repeater cards).</p> <p>For SR512-supported LIS, enter NT9X96AA (LIS F-bus controller card).</p> <p>Enter NIL (no front card) for optional termination datafill only.</p> <p>Any entry outside the range listed for this field is invalid.</p>

**SUSHELF** (continued)**Field descriptions**

Field	Subfield or refinement	Entry	Explanation and action
	BACKPEC	NT9X79AA NT9X79BA NT9X98AA NTEX20AA NTEX20BA or NIL	<p><i>Back card product engineering code</i></p> <p>Enter the PEC of the back card.</p> <p>Enter NT9X79AA or NT9X79BA (F-bus termination paddle board) to terminate the F-bus on the last LIS in single F-bus configuration.</p> <p>Enter NT9X79BA (F-bus termination paddle board) to terminate an F-bus in triple F-bus configuration.</p> <p>Enter NT9X98AA (LIS fiber interface paddle board) for SR512 supported LIS only.</p> <p>Enter NTEX20AA (intrashelf termination paddle board) to terminate F-bus 0.</p> <p>Enter NTEX20BA (intrashelf termination paddle board) to terminate F-bus 1.</p> <p>Enter NIL for power converters. They do not extend to the backplane.</p> <p><b>Note:</b> PECs for TFI and LFC cards cannot be mixed.</p>
CONTMARK		+ or \$	<p><i>Continuation mark</i></p> <p>Enter + if additional information for this tuple is contained in the next record. Otherwise, enter \$ to indicate the end of the tuple.</p>

**Datafill example**

The following example shows sample datafill for table SUSHELF.

**MAP display example for table SUSHELF**

SHELFKEY	FLOOR	ROW	FRAMEPOS	FRAMETYP	FRAMENUM	SHELFPOS	SHELFPEC	CARDINFO
LIM 2 9 0 3 3		C	2	LIM	501	0	NT9X72BA	(7 NT9X74DA NT9X79BA) (30 NIL NTEX20AA) (32 NT9X74DA NT9X79BA)
								(1 NTDX16AA NIL) (4 NTDX16AA NIL)\$ (8 NIL NTEX20BA) (33 NTDX16AA NIL) (36 NTDX16AA NIL)\$

## **SUSHELF** (end)

---

### **Table history**

#### **SN06 (DMS)**

Card NT9X30AB is discontinued and replaced by NT9X30AC.

#### **TL11**

SHELFKEY field changed to allow for the addition of CARDNUMs 7, 8, and 9 as TFI cards to support triple F-bus configuration.

#### **TL07**

SHELFKEY field changed to allow for the addition of CARDNUMs 7, 8, and 9 as TFI cards to support triple F-bus configuration for STP product.

#### **CSP03**

NTDX16 product engineering code was added.

Changes made to datafill information to show that F-bus must be busied in order for entries in table SUSHELF to be modified.

#### **BCS36**

New shelf product engineering code was added.

### **Supplementary information**

New warning and error messages have been introduced for control number and LIS number datafill actions in STP04.0.



---

## SVCDATA

---

### Table name

Switch Packet Configuration Table

### Functional description

Table SVCDATA stores switch-wide parameters for packet service and provides access to these parameters.

### Datafill sequence and implications

Table LATANAME must be datafilled before table SVCDATA.

### Table size

1 tuple

The store is protected store made accessible to users by table control. The pertinent data is available for distribution to the X.25 and X.75 service groups (XSG).

### Datafill

The following table lists datafill for table SVCDATA.

#### Field descriptions

Field	Subfield or refinement	Entry	Explanation and action
KEY		see subfield	<i>Key</i> This field is the key to the table and consists of subfield DATAKEY.
	DATAKEY	alphanumeric (up to 16 characters)	<i>Data key</i> Enter the data key.
SWOPTS		see subfields	<i>Switch options</i> This field consists of subfield SVCTYPE and refinements.
	SVCTYPE	DNCHNLB DNCHNLD DNCTINFO  or ISDNPH	<i>Service type</i> Enter the service type required and datafill the refinements that apply for the specified service type.

**SVCDATA** (continued)**SVCTYPE = DNCHNLB and B\_OPTIONS = DTCA**

If the entry in field SVCTYPE is DNCHNLB and the entry in field B\_OPTIONS is DTCA, datafill refinement DTCA as described below.

**Field descriptions for conditional datafill**

<b>Field</b>	<b>Subfield or refinement</b>	<b>Entry</b>	<b>Explanation and action</b>
	B_OPTIONS	DTCA, LCA, LLFSQ, LLWS, N2, NDPS, NDWS, PLSQ, T1, T2, or T3	<i>B_options</i> Enter DTCA for default throughput class assignment.
	DTCA	see subfields	<i>Default throughput class assignment</i> This field is a vector that consists of multiples of subfield SUBSCRIBED and refinements. Each entry value must be separated by a blank space.
	SUBSCRIBED	Y or N	<i>Subscribed</i> Enter Y to enable DTCA. The default value is N (no).
	IDTCA	75, 150, 300, 600, 1200, 2400, 4800, 9600, 19200, 48000, 64000	<i>Incoming default throughput class assignment</i> Enter the non-default throughput class for incoming calls. The default value is 64000.
	ODTCA	75, 150, 300, 600, 1200, 2400, 4800, 9600, 19200, 48000, 64000	<i>Outgoing default throughput class assignment</i> Enter the non-default throughput class for outgoing calls. The default value is 64000.

**SVCDATA** (continued)**SVCTYPE = DNCHNLB and B\_OPTIONS = LCA**

If the entry in field SVCTYPE is DNCHNLB and the entry in field B\_OPTIONS is LCA, datafill refinement LCA as described below.

**Field descriptions for conditional datafill (Sheet 1 of 2)**

Field	Subfield or refinement	Entry	Explanation and action
	B_OPTIONS	DTCA, LCA, LLFSQ, LLWS, N2, NDPS, NDWS, PLSQ, T1, T2, or T3	<i>B_options</i> Enter LCA to specify the logical channel assignment for each type of service at the time of subscription.
	LCA	see subfields	<i>Logical channel assignment</i> This field is a vector that consists of up to 5 multiples of subfield LCA_OPTIONS and refinements. Each entry value must be separated by a blank space.
	LCA_ -OPTIONS	NNRC NOWI NOWONPVC or SLCN	<i>Logical channel assignment options</i> Enter NNRC to specify the number of non-restricted logical channels and datafill subfield NNRC.  Enter NOWI to specify the number of one-way incoming logical channels and datafill subfield NOWI.  Enter NOWO to specify the number of one-way outgoing logical channels and datafill subfield NOWO.  Enter NPVC to specify the number of permanent virtual circuits and datafill subfield NPVC.  Enter SLCN to specify the starting channel for the logical channel assignment and datafill subfield SLCN.  <b>Note:</b> The sum of NNRC, NOWI, NOWO, and NPVC must be between 1 and 512. The sum of all options must be less than 4096.

**SVCDATA** (continued)**Field descriptions for conditional datafill (Sheet 2 of 2)**

Field	Subfield or refinement	Entry	Explanation and action
	NNRC	1 to 512	<i>Number of non-restricted channels</i> Enter a numeric value to specify the NNRC. The default value is 1.
	NOWI	0 to 512	<i>Number of one-way incoming logical channels</i> Enter a numeric value to specify the NOWI. The default value is 0 (zero).
	NOWO	0 to 512	<i>Number of one-way outgoing logical channels</i> Enter a numeric value to specify the NOWO. The default value is 0 (zero).
	NPVC	0 to 512	<i>Number of permanent virtual circuits</i> Enter a numeric value to specify the NPVC. The default value is 0 (zero).
	SLCN	1 to 4095	<i>Start logical channel number</i> Enter a numeric value to specify the SLCN. The default value is 1.

**SVCTYPE = DNCHNLB and B\_OPTIONS = LLFSQ**

If the entry in field SVCTYPE is DNCHNLB and the entry in field B\_OPTIONS is LLFSQ, datafill refinement LLFSQ as described below.

**Field descriptions for conditional datafill**

Field	Subfield or refinement	Entry	Explanation and action
	B_OPTIONS	DTCA, LCA, LLFSQ, LLWS, N2, NDPS, NDWS, PLSQ, T1, T2, or T3	<i>B_options</i> Enter LLFSQ to specify the sequencing number of frames allowed for each direction of communication.
	LLFSQ	MOD8 or MOD128	<i>Link level frame sequencing</i> Enter MOD8 for modulo 8. Enter MOD128 for modulo 128. The default value is MOD8.

**SVCDATA** (continued)**SVCTYPE = DNCHNLB and B\_OPTIONS = LLWS**

If the entry in field SVCTYPE is DNCHNLB and the entry in field B\_OPTIONS is LLWS, datafill refinement LLWS as described below.

**Field descriptions for conditional datafill**

Field	Subfield or refinement	Entry	Explanation and action
	B_OPTIONS	DTCA, LCA, LLFSQ, LLWS, N2, NDPS, NDWS, PLSQ, T1, T2, or T3	<i>B_options</i> Enter LLWS to specify the maximum number of frames allowed in transit at one time.
	LLWS	1 to 127	<i>Link level window size</i> Enter 1 to 7 for MOD8 (modulo 8). Enter 1 to 127 for MOD128 (modulo 128). The default value is 7.

**SVCTYPE = DNCHNLB and B\_OPTIONS = N2**

If the entry in field SVCTYPE is DNCHNLB and the entry in field B\_OPTIONS is N2, datafill refinement N2 as described below.

**Field descriptions for conditional datafill**

Field	Subfield or refinement	Entry	Explanation and action
	B_OPTIONS	DTCA, LCA, LLFSQ, LLWS, N2, NDPS, NDWS, PLSQ, T1, T2, or T3	<i>B_options</i> Enter N2 to specify the maximum number of attempts to compile a successful retransmission.
	N2	2 to 15	<i>Maximum retransmissions</i> Enter the maximum retransmissions. The default value is 3.

**SVCDATA** (continued)**SVCTYPE = DNCHNLB and B\_OPTIONS = NDPS**

If the entry in field SVCTYPE is DNCHNLB and the entry in field B\_OPTIONS is NDPS, datafill refinement NDPS as described below.

**Field descriptions for conditional datafill**

Field	Subfield or refinement	Entry	Explanation and action
	B_OPTIONS	DTCA, LCA, LLFSQ, LLWS, N2, NDPS, NDWS, PLSQ, T1, T2, or T3	<i>B_options</i> Enter NDPS enable the user to subscribe to a maximum packet size for each direction of communication.
	NDPS	see subfields	<i>Non-default packet size</i> This field is a vector that consists of multiples of subfield SUBSCRIBED and refinements. Each entry value must be separated by a blank space.
	SUBSCRIBED	Y or N	<i>Subscribed</i> Enter Y (yes) to enable NDPS. The default value is N (no).
	IMPS	16, 32, 64, 128, 256	<i>Incoming maximum packet size</i> Enter the non-default packet size for incoming calls.
	OMPS	16, 32, 64, 128, 256	<i>Outgoing maximum packet size</i> Enter the non-default packet size for outgoing calls.

**SVCDATA** (continued)**SVCTYPE = DNCHNLB and B\_OPTIONS = NDWS**

If the entry in field SVCTYPE is DNCHNLB and the entry in field B\_OPTIONS is NDWS, datafill refinement NDWS as described below.

**Field descriptions for conditional datafill**

Field	Subfield or refinement	Entry	Explanation and action
	B_OPTIONS	DTCA, LCA, LLFSQ, LLWS, N2, NDPS, NDWS, PLSQ, T1, T2, or T3	<i>B_options</i> Enter NDWS enable non-standard default packet layer window size for each direction of communication.
	NDWS	see subfields	<i>Non-standard default window size</i> This field is a vector that consists of multiples of subfield SUBSCRIBED and refinements. Each entry value must be separated by a blank space.
	SUBSCRIBED	Y or N	<i>Subscribed</i> Enter Y (yes) to enable NDWS. The default value is N (no).
	IPLWS	1 to 127	<i>Incoming packet layer window size</i> Enter the non-standard packet layer window size for incoming calls. Enter 1 to 7 for MOD8 (modulo 8) or 1 to 127 for MOD128 (modulo 128). The default value is 2 if the entry in field SUBSCRIBED is N.
	OPLWS	1 to 127	<i>Outgoing packet layer window size</i> Enter the non-standard packet layer window size for outgoing calls. Enter 1 to 7 for MOD8 or 1 to 127 for MOD128. The default value is 2 if the entry in field SUBSCRIBED is N.

**SVCDATA** (continued)**SVCTYPE = DNCHNLB and B\_OPTIONS = PLSQ**

If the entry in field SVCTYPE is DNCHNLB and the entry in field B\_OPTIONS is PLSQ, datafill refinement PLSQ as described below.

**Field descriptions for conditional datafill**

Field	Subfield or refinement	Entry	Explanation and action
	B_OPTIONS	DTCA, LCA, LLFSQ, LLWS, N2, NDPS, NDWS, PLSQ, T1, T2, or T3	<i>B_options</i> Enter PLSQ to specify the sequential numbering of packets for each direction of communication.
	PLSQ	MOD8 or MOD128	<i>Packet level sequencing</i> Enter MOD8 for modulo 8. Enter MOD128 for modulo 128. The default value is MOD8.

**SVCTYPE = DNCHNLB and B\_OPTIONS = T1**

If the entry in field SVCTYPE is DNCHNLB and the entry in field B\_OPTIONS is T1, datafill refinement T1 as described below.

**Field descriptions for conditional datafill**

Field	Subfield or refinement	Entry	Explanation and action
	B_OPTIONS	DTCA, LCA, LLFSQ, LLWS, N2, NDPS, NDWS, PLSQ, T1, T2, or T3	<i>B_options</i> Enter T1 to specify the time period between the transmission of consecutive frames.
	T1	10 to 200	<i>Acknowledgement timer</i> Enter the time between frames in units of 100 ms. The default value is 20 (2 s).



**SVCDATA** (continued)**SVCTYPE = DNCHNLB and B\_OPTIONS = T2**

If the entry in field SVCTYPE is DNCHNLB and the entry in field B\_OPTIONS is T2, datafill refinement T2 as described below.

**Field descriptions for conditional datafill**

Field	Subfield or refinement	Entry	Explanation and action
	B_OPTIONS	DTCA, LCA, LLFSQ, LLWS, N2, NDPS, NDWS, PLSQ, T1, T2, or T3	<i>B_options</i> Enter T2 to specify the response time between the reception of the last bit of a frame and the sending of the corresponding acknowledgement.
	T2	0 to 4	<i>Response timer</i> Enter the response time in units of 100 ms. The default value is 2 (200 ms).

**SVCTYPE = DNCHNLB and B\_OPTIONS = T3**

If the entry in field SVCTYPE is DNCHNLB and the entry in field B\_OPTIONS is T3, datafill refinement T3 as described below.

**Field descriptions for conditional datafill**

Field	Subfield or refinement	Entry	Explanation and action
	B_OPTIONS	DTCA, LCA, LLFSQ, LLWS, N2, NDPS, NDWS, PLSQ, T1, T2, or T3	<i>B_options</i> Enter T3 to specify the time LAPB stays idle before layer 3 applies failure procedures.
	T3	1 to 30	<i>Idle channel timer</i> Enter the idle time in seconds. The default value is 5.

**SVCDATA** (continued)**SVCTYPE = DNCHNLD and D\_OPTIONS = DTCA**

If the entry in field SVCTYPE is DNCHNLD and the entry in field D\_OPTIONS is DTCA, datafill refinement DTCA as described below.

**Field descriptions for conditional datafill**

Field	Subfield or refinement	Entry	Explanation and action
	D_OPTIONS	DTCA , LCA NDPS, NDWS, or PLSQ	<i>D_options</i> Enter DTCA for default throughput class assignment.
	DTCA	see subfields	<i>Default throughput class assignment</i> This field is a vector that consists of multiples of subfield SUBSCRIBED and refinements. Each entry value must be separated by a blank space.
	SUBSCRIBED	Y or N	<i>Subscribed</i> Enter Y to enable DTCA. The default value is N (no).
	IDTCA	75, 150, 300, 600, 1200, 2400, 4800, 9600	<i>Incoming default throughput class assignment</i> Enter the non-default throughput class for incoming calls.
	ODTCA	75, 150, 300, 600, 1200, 2400, 4800, 9600	<i>Outgoing default throughput class assignment</i> Enter the non-default throughput class for outgoing calls.

**SVCDATA** (continued)

**SVCTYPE = DNCHNLD and D\_OPTIONS = LCA**

If the entry in field SVCTYPE is DNCHNLD and the entry in field D\_OPTIONS is LCA, datafill refinement LCA as described below.

**Field descriptions for conditional datafill (Sheet 1 of 2)**

Field	Subfield or refinement	Entry	Explanation and action
	D_OPTIONS	DTCA, LCA, NDPS, NDWS, or PLSQ	<i>D_options</i> Enter LCA to specify the logical channel assignment for each type of service at the time of subscription.
	LCA	see subfields	<i>Logical channel assignment</i> This field is a vector that consists of up to 5 multiples of subfield LCA_OPTIONS and refinements. Each entry value must be separated by a blank space.
	LCA_OPTIONS	NNRC NOWI NOWONPVC or SLCN	<i>Logical channel assignment options</i> Enter NNRC to specify the number of non-restricted logical channels and datafill subfield NNRC.  Enter NOWI to specify the number of one-way incoming logical channels and datafill subfield NOWI.  Enter NOWO to specify the number of one-way outgoing logical channels and datafill subfield NOWO.  Enter NPVC to specify the number of permanent virtual circuits and datafill subfield NPVC.  Enter SLCN to specify the starting channel for the logical channel assignment and datafill subfield SLCN.  <b>Note:</b> The sum of NNRC, NOWI, NOWO, and NPVC must be between 1 and 64. The sum of all options must be less than 4096.
	NNRC	1 to 64	<i>Number of non-restricted channels</i> Enter a numeric value to specify the NNRC. The default value is 1.

**SVCDATA** (continued)**Field descriptions for conditional datafill (Sheet 2 of 2)**

Field	Subfield or refinement	Entry	Explanation and action
	NOWI	0 to 64	<i>Number of one-way incoming logical channels</i>  Enter a numeric value to specify the NOWI. The default value is 0 (zero).
	NOWO	0 to 64	<i>Number of one-way outgoing logical channels</i>  Enter a numeric value to specify the NOWO. The default value is 0 (zero).
	NPVC	0 to 64	<i>Number of permanent virtual circuits</i>  Enter a numeric value to specify the NPVC. The default value is 0 (zero).
	SLCN	1 to 4095	<i>Start logical channel number</i>  Enter a numeric value to specify the SLCN. The default value is 1.

**SVCTYPE = DNCHNLD and D\_OPTIONS = NDPS**

If the entry in field SVCTYPE is DNCHNLD and the entry in field D\_OPTIONS is NDPS, datafill refinement NDPS as described below.

**Field descriptions for conditional datafill (Sheet 1 of 2)**

Field	Subfield or refinement	Entry	Explanation and action
	D_OPTIONS	DTCA, LCA, NDPS, NDWS, or PLSQ	<i>D_options</i>  Enter NDPS enable the user to subscribe to a maximum packet size for each direction of communication.
	NDPS	see subfields	<i>Non-default packet size</i>  This field is a vector that consists of multiples of subfield SUBSCRIBED and refinements. Each entry value must be separated by a blank space.
	SUBSCRIBED	Y or N	<i>Subscribed</i>  Enter Y (yes) to enable NDPS. The default value is N (no).

**SVCDATA** (continued)**Field descriptions for conditional datafill (Sheet 2 of 2)**

Field	Subfield or refinement	Entry	Explanation and action
	IMPS	16, 32, 64, 128, 256	<i>Incoming maximum packet size</i> Enter the non-default packet size for incoming calls.
	OMPS	16, 32, 64, 128, 256	<i>Outgoing maximum packet size</i> Enter the non-default packet size for outgoing calls.

**SVCTYPE = DNCHNLD and D\_OPTIONS = NDWS**

If the entry in field SVCTYPE is DNCHNLD and the entry in field D\_OPTIONS is NDWS, datafill refinement NDWS as described below.

**Field descriptions for conditional datafill (Sheet 1 of 2)**

Field	Subfield or refinement	Entry	Explanation and action
	D_OPTIONS	DTCA, LCA, NDPS, NDWS, or PLSQ	<i>D_options</i> Enter NDWS enable non-standard default packet layer window size for each direction of communication.
	NDWS	see subfields	<i>Non-default window size</i> This field is a vector that consists of multiples of subfield SUBSCRIBED and refinements. Each entry value must be separated by a blank space.
	SUBSCRIBED	Y or N	<i>Subscribed</i> Enter Y (yes) to enable NDWS. The default value is N (no).

**SVCDATA** (continued)**Field descriptions for conditional datafill (Sheet 2 of 2)**

Field	Subfield or refinement	Entry	Explanation and action
	IPLWS	1 to 127	<i>Incoming packet layer window size</i>  Enter the non-standard packet layer window size for incoming calls. Enter 1 to 7 for MOD8 (modulo 8) or 1 to 127 for MOD128 (modulo 128). The default value is 2 if the entry in field SUBSCRIBED is N.
	OPLWS	1 to 127	<i>Outgoing packet layer window size</i>  Enter the non-standard packet layer window size for outgoing calls. Enter 1 to 7 for MOD8 or 1 to 127 for MOD128. The default value is 2 if the entry in field SUBSCRIBED is N.

**SVCTYPE = DNCHNLD and D\_OPTIONS = PLSQ**

If the entry in field SVCTYPE is DNCHNLD and the entry in field D\_OPTIONS is PLSQ, datafill refinement PLSQ as described below.

**Field descriptions for conditional datafill**

Field	Subfield or refinement	Entry	Explanation and action
	D_OPTIONS	DTCA, LCA, NDPS, NDWS, or PLSQ	<i>D_options</i>  Enter PLSQ to specify the sequential numbering of packets for each direction of communication.
	PLSQ	MOD8 or MOD128	<i>Packet level sequencing</i>  Enter MOD8 for modulo 8. Enter MOD128 for modulo 128. The default value is MOD8.

**SVCDATA** (continued)

**SVCTYPE = DNCTINFO**

If the entry in field SVCTYPE is DNCTINFO, datafill refinement TSD\_OPTION as described below.

**Field descriptions for conditional datafill (Sheet 1 of 3)**

Field	Subfield or refinement	Entry	Explanation and action
	TSD_OPTION	FCPN, FSA, ICB, ICS, LCP, OCB, RCA, RPOAB, TCN	<p><i>Packet handler options</i></p> <p>This field is a vector that consists of up to 9 multiples and refinements. Each entry must be separated by a blank space.</p> <p>Enter FCPN (flow control parameter negotiation allowed) to enable the enable the calling user to negotiate flow control parameters (layer size and window size) for each direction of communication on a virtual call. Enter Y (enabled) in subfield SUBSCRIBED. The default value is N (not enabled).</p> <p>Enter FSA (fast select acceptance) to enable the called party to receive incoming fast select calls. Enter Y (accepted) in subfield SUBSCRIBED. The default value is N (not accepted).</p> <p>Enter ICB (incoming calls barred) to prohibit the network from accepting any outgoing call requests from a user subscribing to the service. Enter Y (accepted) in subfield SUBSCRIBED. The default value is N (not accepted).</p> <p>Enter ICS (interexchange carrier subscription) to enable the user to select a preferred interexchange carrier. Enter Y (selection enabled) in subfield SUBSCRIBED and datafill refinements E164RPOA and X121RPOA. The default value for subfield SUBSCRIBED is N (not enabled).</p> <p>Enter LCP (local charging prevention) to prohibit subscribers from charging virtual calls to their ISDN directory number. Enter Y (enabled) in subfield SUBSCRIBED. The default value is N (not enabled).</p>

**SVCDATA** (continued)

## Field descriptions for conditional datafill (Sheet 2 of 3)

Field	Subfield or refinement	Entry	Explanation and action
			<p>Enter OCB (outgoing calls barred) to prohibit the network from accepting any outgoing call requests from a user subscribing to the service. Enter Y (accepted) in subfield SUBSCRIBED. The default value is N (not accepted).</p> <p>Enter RCA (reverse charging accepted) to enable the called party to accept charges for a call. Enter Y (accepted) in subfield SUBSCRIBED. The default value is N (not accepted).</p> <p>Enter RPOAB (recognized private operating company selection barred) to prohibit the user from signaling a transit carrier for handling an intraLATA or interLATA call. Enter Y (barred) in subfield SUBSCRIBED. The default value is N (unbarred).</p> <p>Enter TCN (throughput negotiation allowed) to enable the calling user, called user, and network to engage in a negotiation of throughput class. Enter Y (enabled) in subfield SUBSCRIBED. The default value is N (not enabled).</p>
	SUBSCRIBED	Y or N	<p><i>Subscribed</i></p> <p>Enter Y (yes) to enable or accept a packet handler option. N (no) is the default entry for all options.</p>



**SVCDATA** (continued)**Field descriptions for conditional datafill (Sheet 3 of 3)**

Field	Subfield or refinement	Entry	Explanation and action
	E164RPOA	vector of four digits (0 to 9)	<i>E.164 registered private operating agency</i> If the entry in field TSD_OPTION is ICS and the entry in field SUBSCRIBED is Y, enter the domestic network identification code (DNIC) or international network identification code (INIC) to specify the preselected ISDN packet interexchange carrier.
	X121RPOA	vector of four digits (0 to 9)	<i>X.121 registered private operating agency</i> If the entry in field TSD_OPTION is ICS and the entry in field SUBSCRIBED is Y, enter the DNIC or INIC to specify the preselected PSPN packet interexchange carrier.

**SVCTYPE = ISDNPH**

If the entry in field SVCTYPE is ISDNPH, datafill refinement PHOPTS as described below.

**Field descriptions for conditional datafill (Sheet 1 of 5)**

Field	Subfield or refinement	Entry	Explanation and action
	PHOPTS	see subfields	<i>Packet handler options</i> This field is a vector that consists of up to ten multiples of subfield SW_SEL and refinements. Each entry value must be separated by a blank space.
	SW_SEL	alphanumeric	<i>Switch option selector</i> Enter the name of the packet service parameter that requires changing, and datafill the refinement subfield for this parameter.
		TRDELAY	If the switch transit delay requires changing, enter TRDELAY and datafill subfield DELAY.
		PVCINTV	If the permanent virtual circuit (PVC) requires changing, enter PVCINTV and datafill subfield MS.

**SVCDATA** (continued)**Field descriptions for conditional datafill (Sheet 2 of 5)**

Field	Subfield or refinement	Entry	Explanation and action
		X75LATAN	If the X*75 local access transport area (LATA) name requires changing, enter X75LATAN and datafill subfield LATA.
		CHARFAIL	If the chargeable failed call attempt indicator requires changing, enter CHARFAIL and datafill subfield BOOLPARM.
		INTERSUP	If the internetwork billing suppression indicator requires changing, enter INTERSUP and datafill subfield BOOLPARM.
		SEGSIZE	If the segment size requires changing, enter SEGSIZE and datafill subfield SIZE.
		SEGTHRES	If the segment count overflow threshold requires changing, enter SEGTHRES and datafill subfield PERCENT.
		SENSORID	If the originating sensor identifier requires changing, enter SENSORID and datafill subfield SIXDIGIT.
		SECONSUB	If the secondary subclass requires changing, enter SECONSUB and datafill subfield THREEBIT.
		INIC	If the switch international network identification code (INIC) requires changing, enter INIC and datafill subfield NICODE.
	DELAY	0 to 32767	<i>Switch transit delay</i>  Enter a numeric value in milliseconds for the switch transit delay. This number, which represents the delay imposed by a switch on an X*25 intraswitch call, must be distributed to all X*25 and X*75 link interface units (XLIU). The default value is 0 (zero).

**SVCDATA** (continued)

## Field descriptions for conditional datafill (Sheet 3 of 5)

Field	Subfield or refinement	Entry	Explanation and action
	MS	300 to 6000	<p><i>PVC retry interval</i></p> <p>Enter a numeric value in 100-ms units for the PVC retry interval. This interval is the time period that the DMS packet handler (DMS PH) waits after it fails a PVC call. When the time period elapses, the DMS PH reattempts the call. The default value is 600 (which corresponds to 60 s).</p>
	LATA	NILLATA LATA1LATA2	<p><i>X*75 LATA name</i></p> <p>Enter a character string to assign a default originating LATA to a character string. This LATA information and the called number are used to determine the LATA status of an incoming trunk call. This name is only present at the computing module (CM), only active with equal access offices, and can only be changed if there is an equal access packet supported.</p> <p>For offices that are not equal access, the name cannot be changed from the default value. The default value is NILLATA.</p>
	BOOLPARM	Y or N	<p><i>Boolean flag</i></p> <p>The function of this field, which is only present at the CM, is dependent upon the SW_SEL selector value.</p> <p>If SW_SEL has value CHARFAIL, enter Y (yes) to indicate that a failed call attempt is chargeable or enter N (no) to indicate that it is not chargeable. The default value is Y.</p> <p>If SW_SEL has value INTERSUP, enter Y to indicate that accounting is suppressed on all internetwork calls or enter N to indicate that it is not suppressed. The default value is Y.</p>

**SVCDATA** (continued)

## Field descriptions for conditional datafill (Sheet 4 of 5)

Field	Subfield or refinement	Entry	Explanation and action
	SIZE	64 128 or 256	<p><i>Segment size</i></p> <p>A segment is the measurement unit used for charging for the volume of information transmitted or received. The segment size is the number of octets of data contained in a packet segment. The number of segments in a packet is determined by dividing the number of octets of user data contained in a chargeable packet by the segment size and rounding up. A chargeable packet that contains no user data is counted as one segment.</p> <p>Enter a value to represent the segment size required. When the value is changed, a warning is issued to indicate that the user must return to service all XLIUs in order to prevent inaccurate billing. The default value is 64.</p>
	PERCENT	10, 20, 30, 40, 50, 60, 70, 80, or 90	<p><i>Segment count overflow threshold</i></p> <p>Enter a percentage (in units of 10) of the maximum possible segment count used by DMS PH. This is used to activate the count at which an Automatic Message Accounting (AMA) record is generated and the segment counter reset. This number, which requires distribution to the XLIUs, has a default value of 50.</p>
	SIXDIGIT	vector of six digits (0 to 9)	<p><i>Sensor identification digits</i></p> <p>Enter a string of six digits to identify the originating sensor. The default for this vector is 0 0 0 0 0 0.</p>

**SVCDATA** (continued)**Field descriptions for conditional datafill (Sheet 5 of 5)**

Field	Subfield or refinement	Entry	Explanation and action
	THREEBIT	0 to 7	<p><i>Secondary subclass</i></p> <p>Enter a digit that corresponds to the three-bit field of the secondary subclass. This field is used by the tariff utility and the access characteristics first octet. The default value is 0 (zero).</p>
	NICODE	vector or four digits (0 to 9)	<p><i>Switch international identification code</i></p> <p>Enter a four-digit numeric string containing the country code and serving numbering plan area (SNPA). The first digit cannot be a 0 (zero). This numeric string, which requires distribution to the XLIUs, is an international identification code (INIC). The default value is 9001, which is not valid for call processing. This value must be changed to a valid INIC by the operating company.</p>

**Datafill example**

An example of initial datafill for table SVCDATA is shown below. This example shows the appropriate datafill to change values of the packet service parameters in table SVCDATA to meet the following requirements:

- The switch transit delay must be set to 12 ms.
- The switch INIC must be set to 3025.
- The secondary subclass must be 0.
- The sensor ID must be must be set to 123 456.
- The segment count overflow threshold must be set to 20%.
- Accounting must be suppressed on internetwork calls.
- Failed call attempts must be chargeable.
- The segment size must be 64 octets.
- The X\*75 LATA name must be NILLATA.
- The PVC retry interval must be 60 s.

---

**SVCDATA** (end)

---

**MAP display example for table SVCDATA**

KEY	SWOPTS
ISDNPH	
ISDNPH (TRDELAY 12) (INIC 3025) (SECONSUB 0)	
(SENSORID 123456) (SEGTHRES 20) (INTERSUP Y)	
(CHARFAIL Y) (SEGSIZE 64) (X75LATAN NILLATA)	
(PVCINTV 600)	

**Table history****BCS34**

Table SVCDATA was introduced.

**BCS36**

Service types DNCHNLB, DNCHNLD, and DNCTINFO were added to field SVCTYPE.

---

## SVCRATE

---

### Table name

Rate Period Table

### Functional description

Table SVCRATE specifies the rates that are applied for ISDN X.25 packet billing. Billing rates are specified on the basis of the service type, the day of the week, and the hour within a day.

*Note:* The day of the week selector is currently restricted to a value of DAILY.

### Datafill sequence and implications

There is no requirement to datafill other tables prior to table SVCRATE.

### Table size

1 tuple

The size of this table is fixed at one 48-bit tuple.

### Datafill

The following table lists datafill for table SVCRATE.

#### Field descriptions (Sheet 1 of 2)

Field	Subfield or refinement	Entry	Explanation and action
KEY		see subfields	<i>Service rate key</i> This field, which is the key to the table, consists of subfields SVCTYPE and DAY.
	SVCTYPE	ISDNPH	<i>Service type</i> Enter ISDNPH to specify the ISDN packet handler service type.
	DAY	DAILY	<i>Day of week</i> Enter DAILY to specify that the billing rate is to apply for all days of the week.

**SVCRATE** (end)

## Field descriptions (Sheet 2 of 2)

Field	Subfield or refinement	Entry	Explanation and action
DAYTIME		see subfields	<i>Hourly billing rates</i>  This field consists of a vector of up to 24 multiples of subfields ANHOUR and ARATE. Each multiple specifies the billing rate for a 1-h slot. Separate each subfield with a single space. If less than 24 multiples are required, end the list with a \$ (dollar sign).
	ANHOUR	00HOUR to 23HOUR	<i>Hour in day</i>  Enter the name of the hour slot for which a rate must be specified.  Each hour slot name corresponds to the start of the 1-h slot (for example, the entry 02HOUR corresponds to the time slot from 2:00 AM to 3:00 AM).
	ARATE	R1, R2, R3, or R4	<i>Rate for specified hour</i>  Enter the rate for the specified time slot.

**Datafill example**

The following example shows sample datafill for table SVCRATE.

**MAP display example for table SVCRATE**

KEY	DAYTIME
ISDNPH DAILY	
(00HOUR R1) (01HOUR R1) (02HOUR R1) (03HOUR R1) (04HOUR R1)	
(05HOUR R1) (06HOUR R1) (07HOUR R1) (08HOUR R1) (09HOUR R1)	
(10HOUR R1) (11HOUR R1) (12HOUR R1) (13HOUR R1) (14HOUR R1)	
(15HOUR R1) (16HOUR R1) (17HOUR R1) (18HOUR R1) (19HOUR R1)	
(20HOUR R1) (21HOUR R1) (22HOUR R1) (23HOUR R1) \$	

**Table history****BCS34**

Table SVCRATE was introduced.



## SVPRIGRP

---

### Table name

SVPRIGRP

### Functional description

Table SVPRIGRP defines Serving PRI Groups. All primary rate interfaces (PRI) that belong to the same Serving PRI Group are considered to terminate at the same destination. Through table SVPRIGRP, the operating company can support up to 1022 serving PRI groups.

The key PGRPID identifies a serving PRI group in table SVPRIGRP. Table LTDEF references this key to identify logical terminal identifiers (LTID) that belong to a serving PRI group. The system automatically updates the remaining fields in table SVPRIGRP. Updates occur as the operating company adds, modifies, and deletes tuples associated with known serving PRI groups in table LTDEF.

### Available options

The only option now available is Special Handling of Presentation Restricted Numbers (SHPRN). The settings for option SHPRN are shown in the following two tables.

#### SHPRN values to be applied to forwarded calls

Subscription Heading	Calling Party Number	Original Called Number on Calls Forwarded Multiple Times	Last (or only) Forwarding Number
NNNN	No	No	No
YYYY	Yes	Yes	Yes
YNNY	No	No	Yes
NNNY	No	No	Yes
YNYY	No	Yes	Yes
NNYY	No	Yes	Yes

**SVPRIGRP** (continued)

The SHPRN values for direct calls are shown in the following table.

**SHPRN values to be applied to direct calls**

Subscription Heading	Calling Party Number
NNNN	No
YYYY	Yes
YNNY	Yes
NNNY	No
YNYY	Yes
NNYY	No

**Datafill sequence and implications**

Datafill table SVPRIGRP before table LTDEF.

**Table size**

0 to 1022 tuples.

**Datafill**

The following table lists datafill for table SVPRIGRP.

**Field descriptions (Sheet 1 of 2)**

Field	Subfield	Entry	Explanation and action
PGRPID		alphanumeric (up to 16 characters)	This field is the key that identifies the serving PRI group.
NUMMEM		0 to 400 (automatic update)	This field records the number of LTIDs associated with the serving PRI group. The system automatically updates NUMMEM When the operating company adds, modifies, and deletes an LTID associated with the group. Datafill LTIDs in table LTDEF.

**SVPRIGRP** (continued)

**Field descriptions (Sheet 2 of 2)**

Field	Subfield	Entry	Explanation and action
MEMBERS		a vector of LTIDs (automatic update)	This field records the PRI identifiers associated with the serving PRI group. The system automatically updates MEMBERS when the operating company adds, modifies, and deletes an LTID associated with the group. Datafill LTIDs in table LTDEF.
OPTIONS	SHPRN	NNNN,YYYY, YNNY, NNNY,YNYY, NNNY	A list of of options. Special Handling of Presentation Restricted Numbers. Enables the DMS switch to override the delivery of presentation restricted numbers for a servicing PRI group interface. Enter a value for SHPRN. The default value is NNNN. For a description of each entry for option SHPRN see Available Options above.

**Datafill example**

The following example shows sample datafill for table SVPRIGRP.

**MAP display example for table SVPRIGRP**

PGRPID	NUMMEM	MEMBERS	OPTIONS
PRI_TO_MTRL	2	(ISDN 381)	(ISDN 383) \$

The following example shows sample datafill for table SVPRIGRP with the SHPRN option.

---

**SVPRIGRP** (end)

---

**MAP display example for table SVPRIGRP with the SHPRN option**

```
PGRPID                NUMMEM    MEMBERS  OPTIONS
-----
MSR_SRVGRP1 3 (ISDN 109) (ISDN 110) (ISDN 1111)
(SHPRN YYYY)
```

**Table history****NA012**

Added detail about SHPRN.

**NA011**

Added option SHPRN to field descriptions and datafill example for table SVPRIGRP with the SHPRN option.

**NA009**

Table SVPRIGRP was created to support PRI Two B-channel Transfer.

## SVRCKT

---

### Table name

Service Circuit

### Functional description

The following data for each Digitone outpulsing circuit (SVDTMF) appears in Table SVRCKT. This data is also for each R2 interregister signaling circuit (SVMFC) or service observing circuit (SVOBSV):

- the pseudo fixed common language location identifier (CLLI)
- the number the operating company assigns
- the equipment location

The maximum number of Digitone outpulsing circuits, R2 interregister signaling circuits, or service observing circuits is 1024 for each type of circuit.

Call Screening, Monitoring and Intercept (CSMI) Enhancement—Stub Message Deletion, feature 59013873, deletes stub messages on the network based answering service (NBAS) of subscribers. Cards 3X68 on SVDTMF provide dual tone multifrequency (DTMF) outpulsing to delete the stub messages.

### Datafill sequence and meaning

Enter data in Table CLLI before you enter data in table SVRCKT.

### Table size

Field TRKGRSIZ in table CLLI for pseudo CLLIs SVOBSV, SVMFC, and SVDTMF controls the size of table SVRCKT.

**SVRCKT** (continued)**Datafill**

Datafill for table SVRCKT appears in the following table.

**Field descriptions (Sheet 1 of 2)**

Field	Subfield	Entry	Explanation and action
SVCTKEY		see subfields	<i>Service circuit key.</i> This key contains subfields CLLI and NUM.
	CLLI	SVDTMF SVMFC or SVOBSV	<i>Common language location identifier.</i> When the type of the service circuit is a Digitone outpulsing circuit, enter SVDTMF. When the type of service circuit is an R2 interregister signaling circuit, enter SVMFC. When the type of service circuit is a service observing circuit, enter SVOBSV.  <b>Note:</b> Do not use SVMFC if the supporting software for R2 interregister signaling is not available.
	NUM	0 to 1023	<i>Service circuit number.</i> Enter the number that the operating company assigned to the following: <ul style="list-style-type: none"> <li>• the Digitone outpulsing circuit</li> <li>• the R2 interregister signaling circuit</li> <li>• the service observing circuit</li> </ul>
TMTYPE		MTM	<i>Trunk module type.</i> Enter the type of trunk module with the Digitone outpulsing circuit, the R2 interregister signaling circuit, or the service observing circuit.
TMNO		0 to 2047	<i>Trunk module number.</i> Enter the number of the trunk module with the Digitone outpulsing circuit, the R2 interregister signaling circuit, or the service observing circuit.

**SVRCKT** (continued)

## Field descriptions (Sheet 2 of 2)

Field	Subfield	Entry	Explanation and action
TMCKTNO		0 to 29	<p><i>Trunk module circuit number.</i></p> <p>Enter a number equal to the trunk module circuit number assigned to the following:</p> <ul style="list-style-type: none"> <li>• the Digitone outpulsing circuit</li> <li>• the R2 interregister signaling circuit</li> <li>• the service observing circuit</li> </ul> <p><b>Note:</b> When field TMCKTNO is greater than 20, perform a cold restart if you attempt to enter SVDTMF in field CLLI.</p>
CARDCODE		3X68AB 3X68BB or 5X29AB	<p><i>Card code.</i></p> <p>Enter the product engineering code (PEC) for the correct tone card. Card codes for the different circuits are:</p> <p>SVDTMF:</p> <ul style="list-style-type: none"> <li>• 3X68AB (dual-tone multifrequency generator circuit card)</li> <li>• 3X68BB (dual-tone multifrequency generator circuit card)</li> </ul> <p>SVOBSV:</p> <ul style="list-style-type: none"> <li>• 5X29AB (service observing circuit card)</li> </ul> <p>SVMFC:</p> <ul style="list-style-type: none"> <li>• not available</li> </ul> <p><b>Note:</b> Cards 3X68 provide the DTMF outpulsing to delete the stub message left on the NBAS of subscribers. Feature 59013873 introduces this enhancement to CSMI.</p>

**Datafill example**

Sample datafill for table SVRCKT appears in the following example.

**SVRCKT** (end)**MAP example for table SVRCKT**

SVCTKEY		TMTYPE	TMNO	TMCKTNO	CARDCODE
SVDTMF	0	MTM	1	26	3X68AB
SVDTMF	1	MTM	1	27	3X68BB
SVDTMF	2	MTM	1	28	3X68AB
SVDTMF	3	MTM	1	29	3X68BB

### Table History

#### NA013

This release introduces feature 59013873, CSMI Enhancement—Stub Message Deletion, that uses cards 3X68 outpulsing to delete the stub messages.



# SYLNKINV

## Table name

Synchronous Link Inventory Table

## Functional description

Table SYLNKINV defines Building Integrated Timing Supply (BITS) synchronous DS-1 links for remote cluster controller (RCC) nodes. Table SYLNKINV supports all RCC nodes, although the BITS interface is currently available for remote cluster controller 2 (RCC2) nodes only.

*Note:* BITS is not supported. Do not attempt to use this function.

## Datafill sequence and implications

The following tables must be datafilled before table SYLNKINV.

- RCCINV
- RCCPSINV

## Table size

0 to 256 tuples (this is the maximum number of remote peripheral modules [PM] in table RCCINV)

## Datafill

The following table lists datafill for table SYLNKINV.

### Field descriptions (Sheet 1 of 2)

Field	Subfield or refinement	Entry	Explanation and action
RCCNAME		see subfields	Remote cluster controller name. This field consists of subfields SITENM, PMTYPE, and RCCNO.
	SITENM	alphanumeric (up to four characters)	Site name. Enter the site name assigned to the remote location. This entry must also appear in table SITE.
	PMTYPE	alphanumeric	Peripheral module type. Enter the PM type for this link.
	RCCNO	0 to 255	Remote cluster controller number. Enter the RCC number.  <i>Note:</i> This number is unique by office and not by site. Any entry outside this range is invalid.

**SYLNKINV** (end)**Field descriptions (Sheet 2 of 2)**

Field	Subfield or refinement	Entry	Explanation and action
BITSINFO		see subfields	BITS information. This field consists of subfields BITS, PRIMARY, SECONDARY, and REVERTIV.
	BITS	N	BITS. Enter N. The default is N.
	PRIMARY	0 to 53	Primary. This subfield provides the primary link to be connected to BITS. The valid values for RCC2 are 0 and 8.
	SECONDARY	0 to 53 (depends on primary link value)	Secondary. This subfield provides the secondary link to be connected to BITS. The valid values for RCC2 are 0 and 8 (depending on the primary link value).
	REVERTIV	Y or N	Revertive. This subfield indicates if revertive switching between internal reference links is enabled. The default is N.

**Datafill example**

The following example shows sample datafill for table SYLNKINV.

**MAP display example for table SYLNKINV**

RCCNAME	BITSINFO
-----	-----
REM1 RCC2 2	N
REM1 RCC2 0	Y 8 0 Y
REM1 RCC2 1	Y 0 8 N

**Table history****NA008**

Table SYLNKINV has been updated for the NA011 release of this document. This update was made in response to a Problem Resolution System (PRS) request for the NA008 timeframe.

**NA004**

Table SYLNKINV was created in NA004.

---

## SYNCLK

---

### Table name

Synchronous Clock Table

### Functional description

Switches arranged for synchronous clock operation require table SYNCLK. You can enter data in this table for the DMS-100 switch (NT40) or the DMS-SuperNode switch.

#### DMS-100

Switches with synchronous clocks can be one of the following types of switches:

- A master external switch in which the central message controller (CMC) clocks synchronizes with an external reference clock.
- A master internal switch that uses the free running oscillator in the synchronizable master clock oscillator (NT3X15AA or NT3X16AA) as the network master clock.
- A slave switch that synchronizes to a master or another slave above the slave in the network hierarchy. This process occurs through clock signals on one of the two assigned DS-1 timing links.

Table SYNCLK allows the user to specify the location of the clock and the timing links. The clock and timing links are for the following peripheral module (PM) types:

- digital carrier module (DCM)
- digital trunk controller (DTC)
- line trunk controller (LTC)

The Stratum-3 and STRAT2P5 clocks (PEC NT3X15) are always on the same shelf as the central control (CC). The system supplies the default values for fields FRTYPE, FRNO, SHPOS, FLOOR, ROW, and FRPOS. The system supplies and ignores these fields.

The Stratum-2 clock (NT3X16) cannot reside on the CC shelf. The Stratum-2 clock can be on an input/output equipment (IOE) frame. This frame must be maximum of 200 feet away from the central message controller (CMC). Overwrite the default values for fields FRTYPE, FRNO, SHPOS, FLOOR, ROW, and FRPOS to reflect the true position of the clock.

The contents of the phase register field do not affect the DCM. For LTCs and DTCs, the phase register field must select the specified register on the time

switch card. This time switch card is hard-wired to the port. This configuration provides the timing link data.

### **DMS SuperNode**

The synchronous clock system handles different office configurations. The synchronous clock system allows the DMS to be a node in the timing network.

In the master external office configuration, the message switch (MS) connects to an external reference source, like a Cesium. This connection synchronizes the DMS system clock. Offices at the top of the network hierarchy use this configuration. Dedicated links that connect to the DMS-bus clock paddleboard (NT9X54) synchronize the DMS clock.

The master internal office configuration uses the internal clock of the DMS to synchronize the office. Offices at the top of the hierarchy and non-Stratum-1 quality use this configuration.

Configuration of the Signaling Transfer Point (STP) offices must occur in the Master Internal Stratum 3 configuration.

The slave office configuration does not have dedicated links incoming to the office to supply the required timing. The system extracts the clock reference source from the incoming digital trunks. To select the digital trunks that the system can use as timing links, enter data in table SYNCLK. You can select two trunks as timing links.

The two trunks that the system uses as timing links do not have limits. The two trunks do not have limits if the following conditions apply:

- the trunks are digital trunks
- the trunks are not on the same DCM
- the trunks are not on the same circuit card if the trunks are on the same DTC or LTC
- the circuit numbers for PMs have a limit of 0 for card 0, and 2 for card 1
- the MS contains the system clocks. Each MS has one clock

Table SYNCLK allows the switch to synchronize the Stratum-3 system clock to the remote Stratum-2 or 2.5 clock. A remote clock contains a Stratum-2 or 2.5 quality oscillator in the NT3X95 remote oscillator shelf.

The DMS uses the slave office configuration to synchronize to another office. For the slave office configuration, the system extracts the synchronization reference from an incoming DS-1 timing link.

**SPM OC-3**

Spectrum Peripheral Module (SPM) optical carrier-level 3 (OC-3) can be provisioned as a timing link when an office is configured in slave mode.

In table SYNCLK, field OFFCONF must be datafilled as SLAVE. This datafill enables selection of SPM as a timing link in field LK0\_PTYP or LK1\_PTYP.

Field LK0\_PNUM or LK1\_PNUM can be datafilled only with existing SPMs defined in table MNNODE. If the requested SPM is not datafilled in table MNNODE, the datafill is rejected and the following message displays: “SPM XX is undefined.” Also, SPMs to be datafilled must be configured in internal timing mode in table MNNODE. Failure to configure the SPM in internal timing mode in table MNNODE results in the datafill being blocked and the following message displays: “SPM XX is not in INTERNAL mode.”

Fields LK0\_PNUM and LK0\_RMTYP or LK1\_PNUM and LK1\_RMTYP combine to form the timing link identifier for an SPM. This translates to a circuit pack on the SPM, which must be defined in table MNCKTPAK prior to the datafill in table SYNCLK. If the circuit pack is not defined correctly, the datafill is rejected and the following message displays: “No OC3 RMs found on SPM XX.” In addition, if the state of the SPM is anything but INSV, the following warning is displayed: “SPM XX is NOT INSV.”

The following list describes additional restrictions imposed in table SYNCLK for OC-3 line timing:

- Stratum 2 and Stratum 2.5 configurations are not supported. An attempt to provision OC-3 as a timing link with Stratum 2 or Stratum 2.5 configurations results in the following message: “SLAVE office with SPM as sync source. Office should be datafilled with STRAT3 clock.”
- A combination of SPM and other PMs as LINK0 and LINK1 is not allowed. An attempt to establish this combination results in the following message: “SPM timing links cannot be provisioned with other PTYP.”

SPMs currently datafilled in table SYNCLK cannot be deleted from table MNNODE without first being removed from table SYNCLK. If the SPMs are not removed from table SYNCLK first, the deletion from table MNNODE is blocked and the following warning displays: “SPM XX is provisioned as Link X in table SYNCLK.” (“Link X” represents LK0 when X=0 and LK1 when X=1. “SPM XX” corresponds to the SPM number being datafilled. XX can have integer values from 0 to 63.)

**Datafill sequence and meaning**

Enter data in the following tables before you enter data in table SYNCLK.

- LTCINV
- LTCPSINV

- DCMINV
- SYNOGLNK, if the load includes this table
- MNNODE, when provisioning SPM OC-3 as a timing link
- MNCKTPAK, when provisioning SPM OC-3 as a timing link

### Table size

The system allocates memory for one default tuple.

### Datafill

Datafill for table SYNCLK appears in the following tables.

Fields descriptions for the DMS-100 switch start on the first page of this document.

Field descriptions for the DMS SuperNode switch start in the table below.

### Field descriptions for DMS-100 switch

Field names, subfield names, and correct data ranges for table SYNCLK for DMS-100 switches appear in the following table.

#### Field descriptions

Field	Subfield or refinement	Entry	Description
KEY		0	<i>Key.</i> Enter the index 0 in the synchronous clock table.  Entries outside the range indicated for this field are not correct.

## Field descriptions

Field	Subfield or refinement	Entry	Description
OFFCONF		MASTER_EXT, MASTER_INT, NON_SYNC, or SLAVE	<p><i>Office configuration.</i> Define the office configuration.</p> <p>Enter MASTER_EXT if the switching unit is configured as a master with an external reference clock.</p> <p>Enter MASTER_INT if the switching unit is configured as a master with the internal clock as a standard.</p> <p>Enter NON_SYNC if the switching unit does not contain synchronous clock hardware.</p> <p>The system initializes field OFFCONF with a value of NON_SYNC.</p> <p>Enter SLAVE if the switching unit is configured as a slave office synchronized through DS-1 to a master switching unit.</p>
CLK0DEF		NON_SYNC_ CLOCK or SYNC_ CLOCK	<p><i>Clock 0 definition.</i> Enter NON_SYNC_CLOCK if clock 0 is not a synchronous clock.</p> <p>Enter SYNC_CLOCK if clock 0 has synchronous clock hardware.</p> <p>The system initializes field CLK0DEF with a value of NON_SYNC_CLOCK.</p>
CLK1DEF		NON_SYNC_ CLOCK or SYNC_ CLOCK	<p><i>Clock 1 definition.</i> Enter NON_SYNC_CLOCK if clock 1 is not a synchronous clock.</p> <p>Enter SYNC_CLOCK if clock 1 has synchronous clock hardware.</p> <p>The system initializes field CLK1DEF with a value of NON_SYNC_CLOCK.</p>

**Field descriptions**

Field	Subfield or refinement	Entry	Description
LK0PTYP		D30_ADTC_TYPE D30_DCA_TYPE D30_DCMT_TYPE D30_IDTC_TYPE D30_PDTC_TYPE D30_TDTC_TYPE D30_TLTC_TYPE DS1_DCM_TYPE DS1_DTC_TYPE DS1_DTCl_TYPE DS1_ICP_TYPE DS1_LTC_TYPE DS1_RMSc_TYPE or SPM	<p><i>Timing link zero peripheral module type.</i>                      Enter the peripheral module (PM) type assigned to timing link 0.</p> <p>Entry D30_DCA_TYPE is for licensee (K+S) use.</p> <p>Entries D30_TDTC_TYPE and D30_TLTC_TYPE are for licensee use.</p> <p>Entries outside the range indicated for this field are not correct.</p>
LK0PNUM		0 to 511	<p><i>Timing link zero peripheral module number.</i>                      Enter the number of the PM assigned to timing link 0 in field LK0PTYP.</p> <p>The DTC or LTC PMs (peripheral modules) can have an assigned value from 0 to 63.</p> <p>SPM can have an assigned value from 0 to 63.</p> <p>Give PM DCM a value from 0 to 511.</p>
LK0CCT		0 to 4	<p><i>Timing link zero circuit number.</i> Enter the circuit card number assigned to timing link 0.</p> <p>Assign DCM DS-1 ports links 0 to 4.</p> <p>The LTC, DTC, PDTC, ADTC, IDTC or DTCl can have DS-1 ports 0 and 2 assigned.</p> <p>The DCA (for K+S) can have DS-1 ports from 0 to 3 assigned.</p> <p>Entries outside the range indicated for this field are not correct.</p>



## Field descriptions

Field	Subfield or refinement	Entry	Description
LK1PTYP		D30_ADTC_TYPE D30_DCA_TYPE D30_DCMT_TYPE D30_IDTC_TYPE D30_PDTC_TYPE D30_TDTC_TYPE D30_TLTC_TYPE DS1_DCM_TYPE DS1_DTC_TYPE DS1_DTCL_TYPE DS1_ICP_TYPE DS1_LTC_TYPE DS1_RMSC_TYPE or SPM	<p><i>Timing link one peripheral module type.</i> Enter the PM type that belongs to timing link 1.</p> <p>Entry D30_DCA_TYPE is for licensee (K+S) use.</p> <p>Entries D30_TDTC_TYPE and D30_TLTC_TYPE are for licensee use.</p> <p>Entries outside the range indicated for this field are not correct.</p>
LK1PNUM		0 to 511	<p><i>Timing link one peripheral module number.</i> Enter the number of the PM assigned to timing link 1.</p> <p>If the entry in field LK1PTYP is a DCM type, the range is 0 to 511.</p> <p>The DTC or LTC PMs can have an assigned value from 0 to 63.</p> <p>SPM can have an assigned value from 0 to 63.</p>
LK1CCT		0 to 4	<p><i>Timing link one circuit number.</i> Enter the circuit card number that belongs to timing link 1.</p> <p>If the entry in field LK1PTYP is a DCM type, the range is 0 to 4.</p> <p>The entry in field LK1PTYPE can be an ADTC, DTC, IDTC, LTC, PDTC, or DTCL type. In this condition, the entry can have DS-1 ports 0 and 2 assigned for office synchronization.</p> <p>If the entry in field LK1PTYPE is a DCA type (for K+S), the entry can have DS-1 ports 0 to 3 assigned.</p> <p>Entries outside the range indicated for this field are not correct.</p>

## Field descriptions

Field	Subfield or refinement	Entry	Description
MOFS		Y or N	<p><i>Master of slaves.</i> Enter Y if the switching unit is a master of slaves. If the switching unit is not the master of slaves, enter N.</p> <p>The system initializes field MOFS with a value of N.</p>
BEAT		Y or N	<p><i>Beat detection.</i> Enter Y if the switching unit is a MASTER_EXT office (field OFFCONF). If the switching unit is not a MASTER_EXT office, enter N.</p> <p>The default value is Y.</p>
FRTYPE		CCC or IOE	<p><i>Frame type.</i> If the entry in field CLOCKPEC, in the following Field descriptions table, is NT3X16, enter data in this refinement. Enter IOE (input/output equipment) or CCC (central control complex).</p> <p>The default for this field is CCC.</p> <p>Entries outside the range indicated for this field are not correct.</p>
FRNO		0 to 511	<p><i>Frame number.</i> If the entry in field CLOCKPEC, in the following Field descriptions table, is NT3X16, enter data in this refinement. Enter the frame number that contains the clock card.</p> <p>The default for this field is 0.</p>
SHPOS		0 to 77	<p><i>Shelf position.</i> If the entry in field CLOCKPEC, in the following Field descriptions table, is NT3X16, data enter this refinement. Enter the shelf position that contains the clock card.</p> <p>The default for this field is 43.</p> <p>Entries outside the range indicated for this field are not correct.</p>
FLOOR		0 to 99	<p><i>Floor.</i> If the entry in field CLOCKPEC, in the following Field descriptions table, is NT3X16, enter data in this refinement. Enter the floor position that contains the clock card.</p> <p>The default entry for this field is 0.</p>

## Field descriptions

Field	Subfield or refinement	Entry	Description
ROW		A to Z, AA to ZZ, except I, II, O, and OO	<p><i>Row.</i> If the entry in field CLOCKPEC, in the following Field descriptions table, is NT3X16, enter data in this refinement. Enter the row on the floor that contains the clock card.</p> <p>The default entry for this field is A.</p>
FRPOS		0 to 99	<p><i>Frame position.</i> If the entry in field CLOCKPEC, in the following Field descriptions table, is NT3X16, enter data in this refinement. Enter the frame position of the bay that contains the clock card.</p> <p>The default entry for this field is 0.</p>
CLOCKPEC		NT3X15 or NT3X16	<p><i>Clock product engineering code.</i> Enter the clock product engineering code (PEC). The PEC for the Stratum-2 clock is NT3X16.</p> <p>The other PECs, like Stratum-3, STRAT2P5) are NT3X15.</p> <p>See the "Additional information" section in this document for information for changes to the clock type.</p>
LOWDRIFT		10 to 75	<p><i>Lower percent drift.</i> Enter the lower percent adjustment. This adjustment causes an alarm. The alarm indicates the sync clock oscillator is out of adjustment and needs readjustment. This value increases by 10, 11, 12.....75.</p>
LALRMLVL		NO_ALARM MINOR MAJOR	<p><i>Lower alarm level.</i> Enter the alarm level the system raises. The system raises the alarm level when the sync clock oscillator reaches the percent adjustment that field LOWDRIFT specifies.</p>
UALRMLVL		NO_ALARM MINOR MAJOR	<p><i>Upper alarm level.</i> Enter the alarm level the the system raises. The system raises the alarm level when the sync clock oscillator reaches the upper percent adjustment that the system defines. The alarm level for UALRMLVL must be greater than or equal to the LALRMLVL alarm level.</p>

## Field descriptions for DMS SuperNode switch

Field names, subfield names, and correct data ranges for table SYNCLK for DMS SuperNode switches appear in the following table.

### Field descriptions

Field	Subfield or refinement	Entry	Description
CLKKEY		0	<i>Clock key.</i> Enter 0 (zero).
CLKDATA		see subfields	<i>Clock data.</i> This field contains subfield CLKTYPE and associated refinements.
	CLKTYPE	STRAT2 STRAT2P5 STRAT3	<p><i>Clock type.</i> Enter the type of clock used in the office. If the entry value is STRAT2 or STRAT2P5, enter data in refinements CLKPEC, FRTYPE, FRNO, SHPOS, FLOOR, ROW, and FRPOS.</p> <p>Enter STRAT3 for STP offices.</p> <p>If the entry value is STRAT3, see refinement OFFCDATA that follows.</p> <p>See the "Additional information" section in this document for information on changes to the clock type.</p>
	CLKPEC	NT3X16AA NT3X16AB NT3X16BA NT3X16BB	<i>Clock product equipment code.</i> If the entry in subfield CLKTYPE is STRAT2 or STRAT2P5, enter data in this refinement. Enter the product engineering code (PEC) of the clock hardware.
	FRTYPE	IOE	<p><i>Frame type.</i> If the entry in subfield CLKTYPE is STRAT2 or STRAT2P5, enter data in this refinement. An IOE (input/output equipment) frame accommodates a STRAT2P5 or a Stratum-2 clock.</p> <p>Entries outside the range indicated for this field are not correct.</p>
	FRNO	0 to 511	<i>Frame number.</i> If the entry in subfield CLKTYPE is STRAT2 or STRAT2P5, enter data in this refinement. Enter the frame number of the clock card.

## Field descriptions

Field	Subfield or refinement	Entry	Description
	SHPOS	0 to 77	<p><i>Shelf position.</i> If the entry in subfield CLKTYPE is STRAT2 or STRAT2P5, enter data in this refinement. Enter the shelf position that contains the clock card.</p> <p>Entries outside the range indicated for this field are not correct.</p>
	FLOOR	0 to 99	<p><i>Floor.</i> If the entry in subfield CLKTYPE is STRAT2 or STRAT2P5, enter data in this refinement. Enter the floor position that contains the clock car.</p>
	ROW	A to Z, AA to ZZ, except I, II, O, and OO	<p><i>Row.</i> If the entry in subfield CLKTYPE is STRAT2 or STRAT2P5, enter data in this refinement. Enter the position that contains the clock card.</p>
	FRPOS	0 to 99	<p><i>Frame position.</i> If the entry in subfield CLKTYPE is STRAT2 or STRAT2P5, enter data in this refinement. Enter the frame position of the bay that contains the clock card.</p>
	OFFCDATA	see subfields	<p><i>Office data.</i> This field contains subfield OFFCONF and the associated refinements.</p>
	OFFCONF	MASTINT MASTEXT SLAVE	<p><i>Office configuration.</i> Enter the correct office configuration. System initialization to MASTINT presets the configuration.</p> <p>Enter MASTEXT for the master external office configuration. Enter data in refinements EXTREQ and EXTSEL.</p> <p>Enter MASTINT for STP offices.</p> <p>Enter MASTINT for the master internal office configuration. This entry does not require additional refinements.</p> <p>Enter SLAVE for the slave office configuration. Enter data in refinements LK0_PTYP, LK0_PNUM, LK0_PCCT, LK0_REG, LK1_PTYP, LK1_PNUM, LK1_PCCT, and LK1_REG in the following section "OFFCONF = SLAVE".</p>

**OFFCONF = MASTEXT**

If the system selects master external office (MASTEXT) configuration, enter data in subfields EXTFREQ and EXTSEL.

**Field descriptions for conditional datafill**

Field	Subfield or refinement	Entry	Description
	EXTFREQ	F64 F1000 F1024 F2048 F2560 F5000 F10000 F10240	<i>External reference frequency.</i> Enter the external reference frequency that the system uses to synchronize the office. The value that you enter defines the frequency in kHz units. For example, F1000 is 1.00 MHz.
	EXTSEL	ANALOG or COMPOSITE	<i>External reference selector.</i> Enter the type of external reference that synchronizes the system clocks. This reference determines the backplane connector on the 9X54AC card that connects to the external source. Stratum-1 type analog signals connect to the coaxial input. Composite signals connect to the 37-pin connector. Composite signals require a BITS connector.  If the value of subfield EXTSEL is ANALOG, enter data in refinement EXTTERM.

## Field descriptions for conditional datafill

Field	Subfield or refinement	Entry	Description
	EXTTERM	T50 or T75	<p><i>External reference termination.</i> If the entry in subfield EXTSEL is ANALOG, enter data in this refinement. Enter the type of coaxial cable that connects the external reference. The ANALOG sources use the following cables: 50 ohm termination (Stratum-1 Cesium) and 75 ohm termination (Stratum-1 Loran-C).</p>
	EXTALARM	MAJOR MINOR OFF	<p><i>External alarm.</i> This field indicates how the system handles SuperNode clock card problems.</p> <p>Enter MAJOR if the system reports Stratum-1 ALARM0 and ALARM1 clock problems. The A10 and A11 clock alarms must indicate problems on the MAP in the SYNC logs. The A10 and A11 clock alarms must reflect the QUERYCK command. Stratum-1 ALARM0 ALARM1 clock problems result in a system action. An example of a system action is a message switch of clock mastership or an office drop SYNC.</p> <p>Enter MINOR if the system reports Stratum-1 ALARM0 and ALARM1 clock problems. The A10 and A11 clock alarms must indicate the problems on the MAP. The clock alarms record the problems in the SYNC logs. The A10 and A11 clock alarms must indicate problems the QUERYCK command. The system action does not handle the Stratum-1 ALARM0 and ALARM1 clock problems.</p> <p>Enter OFF if the system does not report Stratum-1 ALARM0 and ALARM1 clock problems. The A10 and A11 clock alarms associated with these problems are not present on the MAP. The SYNC logs and the command interpreter (CI) QUERYCK command do not contain the A10 and A11 clock alarms associated with these problems.</p>

**OFFCONF = SLAVE**

If the entry in field OFFCONF is slave, enter data in the following refinements:

- LK0\_PTYP
- LK0\_PNUM
- LK0\_CCT
- LK0\_RMTYP
- LK0\_REG
- LK1\_PTYP
- LK1\_PNUM
- LK1\_CCT
- LK0\_RMTYP
- LK1\_REG



## Field descriptions for conditional datafill

Field	Subfield or refinement	Entry	Description
	LK0_PTyp	ADTC, DCA, DCM, DCMT, DTC, DTCl, IDTC, LTC, PDTC, RMSC, or SPM	<p><i>Timing link zero peripheral module type.</i> Enter the type of peripheral module (PM) assigned to timing link 0.</p> <ul style="list-style-type: none"> <li>• ADTC (Austrian digital trunk controller)</li> <li>• DCA (digital carrier access)</li> </ul> <p><b>Note:</b> The DCA is for licensee (K+S) use.</p> <ul style="list-style-type: none"> <li>• DCM (digital carrier module)</li> <li>• DCMT</li> <li>• DTC (digital trunk controller)</li> <li>• DTCl (ISDN digital trunk controller)</li> <li>• LTC (line trunk controller)</li> <li>• PDTC (PCM30 digital trunk controller)</li> <li>• RMSC (remote mobile switching center)</li> <li>• SPM</li> </ul>
	LK0_PNUM	0 to 511	<p><i>Timing link zero peripheral module number.</i> Enter the number of the PM assigned to timing link 0.</p> <p>The range is restricted for SPMs from 0 to 63. Select an SPM that is datafilled as internal in table MNNode.</p>
	LK0_CCT	0 to 4	<p><i>Timing link zero circuit number.</i> Enter the circuit card number that belongs to timing link 0.</p> <p>The DCMs have circuits 0 to 4.</p> <p>The DTC, LTC, PDTC, ADTC, or IDTC use 0 and 8.</p> <p>The DCA DS-1 ports can have circuits 0 to 3 assigned.</p> <p>CCT is not a datafilled value for SPM.</p> <p>Entries outside the range for this field are not correct.</p>

## Field descriptions for conditional datafill

Field	Subfield or refinement	Entry	Description
	LK0_RMTYP	OC3	<i>Timing link zero resource module (RM) type.</i> This field is a refinement over circuit number and was introduced for SPM. The field defines the carrier type of the timing link.
	LK0_REG	0 or 1	<i>Timing link zero phase register.</i> This register indicates the count register from which the system extracts the phase samples.  This field does not affect a DCM. Enter 0 or 1 to satisfy the table editor.
	LK1_PTYP	ADTC, DCA, DCM, DCMT, DTC, DTCI, IDTC, LTC, PDTC, RMSC, or SPM	<i>Timing link one peripheral module type.</i> Enter the type of PM assigned to timing link 1. See field LK0_PTYP.
	LK1_PNUM	0 to 511	<i>Timing link one peripheral module number.</i> Enter the number of the PM assigned to timing link 1.  The range is restricted for SPMs from 0 to 63. Select an SPM that is datafilled as internal in table MNNODE.
	LK1_CCT	0 to 4	<i>Timing link one circuit number.</i> Enter the circuit card number that the system assigns to timing link 1.  The DCMs have circuits 0 to 4.  The DTC, LTC, PDTC, ADTC or IDTC use circuits 0 and 8.  The system assigns DCA DS-1 ports to circuits 0 to 3.  CCT is not a datafilled value for SPM.  Entries outside the range indicated for this field are not correct.

**Field descriptions for conditional datafill**

Field	Subfield or refinement	Entry	Description
	LK1_RMTYP	OC3	<i>Timing link one RM type.</i> This field is a refinement over circuit number and was introduced for SPM. The field defines the carrier type of the timing link.
	LK1_REG	0 or 1	<i>Timing link one phase register.</i> This register indicates the phase count register from which the system extracts timing samples.  This field does not affect a DCM. Enter 0 or 1 to satisfy the table editor.

**Datafill example**

Sample datafill for table SYNCLK appears in the following example.

The operation of the link for a slave DMS SuperNode switching unit appears in the following example.

**MAP example for table SYNCLK**

CLKKEY	CLKDATA	OFFCDATA
0	STRAT3	SLAVE DTC 1 0 0 DTC 0 0 0

**MAP example for table SYNCLK provisioning SPM OC3 as a timing link**

CLKKEY	CLKDATA	OFFCDATA
0	STRAT3	SLAVE SPM 31 OC3 SPM 33 OC3

## Table history

### **SN06 (DMS)**

#### **Q00708926**

Amended circuit card number that belongs to timing link 1 for a PDTC to use circuits 0 and 8.

### **SP13**

Information added for SPM OC-3 line timing.

### **CSP02**

Field REMOTE\_CLOCK\_CONFIG and references to this field were deleted.

### **BCS36**

An additional information section was added to describe return-to-service. A description of field REMOTE\_CLOCK\_CONFIG was added.

## Additional information

This section provides additional information about table SYNCLK.

### **Changes to the clock type**

Changes to the data in table SYNCLK can cause a change in the clock type (stratum). If this condition occurs, the return to service (RTS) requires an out-of-band (OOBAND) option to operate. Use the TSTMS (test message switch) and RTS OOBAND commands to change the clock type. Do not use the standard RTS command.

Use the standard RTS command if data entry changes do not cause the clock type to change.

---

**SYNOGLNK**

---

**Table name**

Synchronous Outgoing Timing Link Table

**Functional description**

Table SYNOGLNK allows the datafill of outgoing timing links. Each tuple includes the peripheral module (PM) type, PM number and PM circuit. Each tuple includes the information for associated downstream office incoming timing links. The operating company can use table SYNOGLNK to record the carriers used as outgoing timing links.

**Datafill sequence and meaning**

You do not need to enter data in other tables before you enter data in table SYNOGLNK.

The entry in field TOCLLI must have the same entry in table CLLI.

**Table size**

0 to 20 tuples

**SYNOGLNK** (continued)

**Datafill**

Datafill for table SYNOGLNK appears in the following table.

**Field descriptions (Sheet 1 of 4)**

Field	Subfield or refinement	Entry	Explanation and action
FROMPTYP		for SuperNode ADTC, DCA, DCM, DCMT, DTC, DTCT, DS1_ICP_TYPE, DS1_HSIE_TYPE, HSI, IDTC, LTC, LTCT, PDTC, or RMSC	<i>From peripheral type.</i> Enter the carrier type of the outgoing timing link. The correct entries are the same correct entries for fields LK0PTYP and LK1PTYP in table SYNCLK in slave configuration.
FROMPTYP (continued)		for NT40 DS1_DCM_TYPE DS1_LTC_TYPE DS1_DTC_TYPE DS1_RMSC_TYPE D30_DCA_TYPE D30_IDTC_TYPE D30_PDTC_TYPE D30_ADTC_TYPE D30_DCMT_TYPED 30_TDTC_TYPE D30_TLTC_TYPE DS1_DTCTI_TYPE DS1_ICP_TYPE DS1_HSI_TYPE or DS1_HSIE_TYPE	<p>Entries after DS1 indicate that the PM is a DS1 type. Entries after D30 indicate that the PM is a D30 type.</p> <ul style="list-style-type: none"> <li>• ADTC (Austrian digital trunk controller)</li> <li>• DCA (Austrian digital carrier module)</li> <li>• DCM (digital carrier module)</li> <li>• DCMT</li> <li>• DTC (digital trunk controller)</li> <li>• DTCT</li> <li>• ICP (integrated cellular peripheral)</li> <li>• HSI (high-speed interface)</li> <li>• HSIE (high-speed interface extended)</li> <li>• IDTC (international digital trunk controller)</li> <li>• LTC (line trunk controller)</li> <li>• PDTC (PCM30 digital trunk controller)</li> <li>• RMSC (remote mobile switching center)</li> <li>• TLTC (Turkish line trunk controller)</li> </ul>
FROMPNUM		0 to 2047	<i>From peripheral number.</i> Enter the PM number of the outgoing timing link.

**SYNOGLNK** (continued)

## Field descriptions (Sheet 2 of 4)

Field	Subfield or refinement	Entry	Explanation and action
FROMCCT		0 to 63 or to 53	<i>From circuit.</i> Enter the T1 circuit number of the outgoing timing link in the PM. If the switch is a SuperNode, the range is 0 to 63. If the switch is an NT40, the range is 0 to 53.
TOCLLI		alphanumeric (a maximum of 11 characters) or \$	<i>To common language location identifier.</i> Enter the common language location identifier (CLLI) code of the corresponding downstream incoming timing link. Enter \$ if a CLLI is not known.
TOSTRAT		STRAT2 STRAT3 STRAT2P5 or \$	<i>To stratum.</i> Enter the system clock stratum of the downstream office. Enter \$ if a downstream stratum is not known.
TODMS		Y or N	<i>To DMS.</i> Enter Y (yes) if the downstream office is a DMS. Enter data in refinements TO_PTYP, TO_PNUM, and TO_CCT. Enter N (no) if the downstream office is not a DMS. Enter data in refinements TO_SPANNO and TO_MISC_INFO.

**SYNOGLNK** (continued)

## Field descriptions (Sheet 3 of 4)

Field	Subfield or refinement	Entry	Explanation and action
TO_PTYP		for SuperNode ADTC, DCA, DCM, DCMT, DTC, DTCT, DS1_ICP_TYPE, DS1_ICP_TYPE DS1_HSIE_TYPE IDTC, LTC, LTCT, HSI, PDTC, or RMSC  for NT40 DS1_DCM_TYPE DS1_LTC_TYPE DS1_DTC_TYPE DS1_RMSC_TYPE D30_DCA_TYPE D30_IDTC_TYPE D30_PDTC_TYPE D30_ADTC_TYPE D30_DCMT_TYPE D30_TDTC_TYPE D30_TLTC_TYPE DS1_DTCL_TYPE DS1_ICP_TYPE DS1_HSI_TYPE or DS1_HSIE_TYPE	<i>To peripheral type.</i> If Y is the entry in field TODMS, enter data in this refinement. Enter the DMS carrier type of the downstream office incoming timing link. The entries for this field must be the same as the entries for field FROMTYP.
TO_PNUM		0 to 2047	<i>To peripheral number.</i> If Y is the entry in field TODMS, enter data in this refinement. Enter the DMS PM number of the downstream office incoming timing link.



**SYNOGLNK** (continued)**Field descriptions (Sheet 4 of 4)**

Field	Subfield or refinement	Entry	Explanation and action
TO_CTT		0 to 63 or to 53	<p>0</p> <p><i>To carrier circuit.</i> If Y is the entry in field TODMS, enter data in this refinement. Enter the DMS T1 carrier circuit number of the downstream office incoming timing link.</p> <p>If the switch is a SuperNode, the range is 0 to 63. If the switch is an NT40, the range is 0 to 53.</p> <p>Enter 0 or 2 for LTC, DTC, IDTC, PDTC, and ADTC.</p> <p>Enter 0, 1, 2 or 3 for DCA.</p> <p>Enter 0, 1, 2, 3 or 4 for DCM and DCMT.</p> <p>For all other PM types, a restriction is not available.</p>
TO_SPANNO		0 to 31 or \$	<p><i>To span number.</i> If N is the entry in field TODMS, enter data in this refinement. Enter the span number of the downstream office incoming timing link. Enter \$ if a span number is not known.</p>
TO_MISC_ -INFO		alphanumeric (a maximum of 16 characters) or \$	<p><i>To miscellaneous information.</i> If N is the entry in field TODMS, enter data in this refinement. Enter the T1 description of the downstream office incoming timing link. This entry identifies the circuit that uses non-DMS terminology. Enter \$ if the character or information is not available.</p>

**Datafill example**

Sample datafill for table SYNOGLNK appears in the following example.

## SYNOGLNK (end)

---

### MAP example for table SYNOGLNK

```
FROMPTYP FROMPNUM FROMCCT          TOCLLI    TOSTRAT
TODMS                TOHWINFO
-----
      LTC          0          15    VANCOUVER_2 (STRAT2P5)$
N      ( 9)$ LINECARD_4_CCT_2
```

### Table history

#### BCS34

Table SYNOGLNK was introduced in BCS34.

**SYSDATA****Table name**

System Data Table

**Functional description**

Table SYSDATA contains a complete list of table names assigned to new table control. This includes all the tables in table CUSTAB that have the value of N (no) in field OLDTC (old table control).

Datafill for this table cannot be changed by the operating company.

One of the following three protection levels are assigned to each table listed in table SYSDATA. A table can only employ one of the levels.

- *SYS*PROT (*system protection*)

The length or contents of a table with system protection cannot be changed by the operating company. Contact Northern Telecom to modify these tables.

- *ENG*PROT (*engineering protection*)

The operating company can modify tables with engineering protection by loading module ENGWRITE from the non-resident tape and entering the command ENGWRITE ON.

- *NIL*PROT (*nil protection*)

All users can modify contents of tables with nil protection.

All tables have nil protection, except those that are listed in the following table.

**Tables that do not have nil protection (Sheet 1 of 2)**

<b>Table name</b>	<b>Protection level</b>
ACLANG	SYS
ALARMTAB	SYS
CUSTAB	SYS
CUSTAREA	SYS
CUSTFLDS	SYS
CUSTPROT	ENG
DATASIZE	SYS

**SYSDATA** (continued)**Tables that do not have nil protection (Sheet 2 of 2)**

Table name	Protection level
DSLIMIT	SYSPROT
FOREIGN_KEY	SYSPROT
KEY_ITEM	SYSPROT
KEY_MAP	SYSPROT
LCCOPT	SYSPROT
LCCOPT_DATA	SYSPROT
LOGICAL_TABLE	SYSPROT
NNASST	SYSPROT
OFCENG	ENGPROT
OFCOPT	SYSPROT
OFCSTD	SYSPROT
OKPARMS	SYSPROT
OPTOPT	SYSPROT
OPTOPT_DATA	SYSPROT
RADR	ENGPROT
SYSDATA	SYSPROT

*Note:* For switches in Turkey, the protection level for table CARRMTC is SYSPROT.

**Datafill sequence and implications**

There is no requirement to datafill other tables prior to table SYSDATA.

**Table size**

The memory allocated to the tables can be dynamically allocated, can have a fixed value, or can depend upon input provided by the operating company. If the memory allocated is dependent on operating company input, then the table is preprinted on the input form for table DATASIZE.

**SYSDATA** (continued)**Datafill**

The following table lists datafill for table SYSDATA.

**Field descriptions**

Field	Subfield or refinement	Entry	Explanation and action
SDKEY		see subfield	<i>System data key</i> This field consists of subfield DATANAME. This is the key to the table.
	DATANAME	alphabetic (1 to 16 characters)	<i>System data name</i> Enter the data name of the table.
DATATYPE		alphanumeric (1 to 32 characters)	<i>Data type</i> Enter the data type of the table.
SIZE		numeric (0 to 32767)	<i>Size</i> Field SIZE serves no datafill purpose. It may determine the amount of store allocated for the table but has no control over the actual size of the table.  <b>Note:</b> If a table is dependent on operating company input, then the table is part of DATASIZE with a preset value equal to the value of field SIZE in table DATASIZE. This value is based on a model, for example, tables CLLI, TRKGRP, and CPOS.
STATUS		AVAILABLE or UNAVAILABLE	<i>Status</i> Enter AVAILABLE or UNAVAILABLE to indicate the status of the table.
PROTLVL		ENGPROT NILPROT or SYSPROT	<i>Protection level</i> Enter the protection level for the table. Enter ENGPROT for engineering protection. Enter NILPROT for nil protection. Enter SYSPROT for system protection.

**Datafill example**

The following example shows sample datafill for table SYSDATA.

## **SYSDATA** (end)

---

### **MAP display example for table SYSDATA**

SDKEY	DATATYPE	SIZE	STATUS
PROTLVL			
PMLOADS NILPROT	PMLOADS_DATATUPLE	50	AVAILABLE

### **Table history**

#### **NA006**

Amended description of field SIZE.

#### **BCS36**

Subfield DATANAME was added.

## **TABLES**

---

### **Table name**

Table TABLES

### **Functional description**

Table TABLES is a software management table that cross-references a number of internal tables. User datafill is not required, the table is displayed for information only.

# TABMON

---

## Table name

Table Monitoring table

## Functional description

This table allows the operating company to activate or deactivate monitoring for each table in the DMS load. If monitoring is active, the operating company can use data in TABMON to activate notification and generation of (TUPL) logs. The system generates these logs for tuple changes, additions, and deletions in the monitored table.

This table functions when software optionality control (SOC) option BASE CO Data Change is on.

## Datafill sequence and meaning

Enter data in the following tables before you enter data in table TABMON:

- SOCVAR
- SOCFEAT
- SOCOPT

## Table size

The size of the table is static. The size of the table depends on the number of tables in the load. You can change only tuples. You cannot add or delete tuples.

## Datafill

Datafill for table TABMON appears in the following table.

### Field descriptions (Sheet 1 of 2)

Field	Subfield or refinement	Entry	Explanation and action
TABNAME		vector of a maximum of 16 alphanumeric characters	Enter the DMS table name.
MONITOR		Y or N	Enter Y to activate table monitoring. Enter N to deactivate table monitoring. The default value is N.



**TABMON** (end)**Field descriptions (Sheet 2 of 2)**

Field	Subfield or refinement	Entry	Explanation and action
LOG		Y or N	Enter Y for TUPL log generation. Enter N to disable TUPL log generation. The default value is N.
FILES		vectors of a maximum of eight characters each	Enter the names of the files where the system sends tuple change notification. The default value is \$ (dollar sign).
OWNER		vector of a maximum of three user names	Enter a maximum of three userids. The system does not notify these users of table datafill changes that the users made. The default value is \$.

**Datafill example**

Sample datafill for table TABMON appears in the following table.

**MAP example for table TABMON**

```

TABNAME MONITOR LOG          FILES  OWNER
-----
CLLI          Y  N  FILE1 FILE2 $ ADMIN $

```

**Table history****BASE07**

Table TABMON was introduced in BASE07.

**Additional information**

Log reports TUPL600, TUPL601, TUPL602, TUPL603, TUPL604, TUPL605, and TUPL606 associate with the table TABMON.

---

## TANDMRTE

---

### Table name

Tandem Routing

### Functional description

Table TANDMRTE is used for direct termination routing to trunks connecting Call Servers within the Interexchange Carrier network.

### Datafill sequence and meaning

None.

### Table size

Memory is allocated for 1000 tuples.

### Datafill

The table that follows lists datafill for the TANDMRTE table.

### Field descriptions

Field	Subfield	Entry	Explanation and action
ROUTE	RTESEL	SQ	Standard route selector with queuing capabilities.
		NQ	Non-Standard route selector with queuing capabilities.
		QH	QH is considered a queue point is placed after the SQ and/or NQ selectors.
SQ	CONNTYP E	D	CONNECTION TYPE. Enter D for direct routing.
		CLLI	Valid CLLI datafilled in table TRKGRP
	OHQ	N or Y	OFFHOOK QUEUING. Enter Y if the trunk group is eligible for queuing.
NQ	CONNTYP E	D	CONNECTION TYPE. Enter D for direct routing.
		CLLI	Valid CLLI datafilled in table TRKGRP

**Field descriptions**

Field	Subfield	Entry	Explanation and action
	DELDIGS	0 TO 15	DELETE DIGITS. Enter the number of digits to delete before outpulsing.
	PRFXDIGS	Up to 11 digits (0 to 9) or N	PREFIX DIGITS. Enter the prefix digits. Enter N for none.
	CANCNOR C	N	CANCEL NORMAL CHARGE. The UCS software does not support this field, enter N.
	OHQ	N or Y	OFFHOOK QUEUING. Enter Y if the trunk group is eligible for queuing.
QH	QTIME	0 TO 255	QUEUE TIME. Enter the time in seconds a call is allowed in the queue.

**Datafill example**

The following example shows sample datafill for table TANDMRTE.

11 (S D IP3IMT744C7DR09) (SQ D IP3IMT745C7DR10 Y) (QH 60)\$

354 (NQ DIP3IMT746C7DR11 3 919 N Y) (QH 90)\$

**Table history****CSP18/SN05**

Feature A19011775 adds table TANDMRTE.

## TAPIDTAB

---

### Table name

Physical Tap Identifier table

### Functional description

Table TAPIDTAB preserves the relationship between integrated link maintenance (ILM) buses and taps and access identifiers over BCS applications.

Direct access to the table cannot occur. The customer contains read-only access. Access that is not direct can occur through data entry of a device that requires ILM supported resources allows access that is not direct. Access that is not direct can occur as part of a restore operation on the N + 1 BCS as part of a BCS application.

### Datafill sequence and meaning

Does not apply. The table is write-protected against direct data entry.

### Table size

0 to 2048 tuples. The number of tuples dynamically determines table size.

### Datafill

Datafill for table TAPIDTAB appears in the following table.

#### Field descriptions (Sheet 1 of 2)

Field	Subfield or refinement	Entry	Explanation and action
ACID		see subfields	<i>Access identifier.</i> The access identifier identifies the tap associated with an access identifier. The ACID field is multiple with three parts: AKEY, AIDX, and ACHNL.
	KEY	0 to 1023	<i>Access key.</i> The access key part of the access identifier.
	INDEX	0 to 1023	<i>Access index.</i> The access index part of the access identifier.
	CHANNEL	0 to 1023	<i>Access channel.</i> The access channel part of the access identifier.

**TAPIDTAB** (end)**Field descriptions (Sheet 2 of 2)**

Field	Subfield or refinement	Entry	Explanation and action
TAPID		see subfields	<i>Tap identifier.</i> The tap identifier is an identifier that ILM uses to identify a tap on a bus. The TAPID tuple is a multiple with three parts. These parts are AKEY, BUSOFST, and TAPOFST.
	AKEY	0 to 1023	<i>Access key.</i> The access key of the bus the tap is on.
	BUSOFST	0 to 255	<i>Bus offset.</i> If more than one bus is on an access key, use the bus offset to differentiate between the buses.
	TAPOFST	0 to 255	<i>Tap offset.</i> The tap offset identifies a tap off a bus.
LOCALID		0 to 255	<i>Local tap identifier.</i> The local tap identifier identifies a tap on an access key.

**Datafill example**

Sample datafill for table TAPIDTAB appears in the following example.

**MAP example for table TAPIDTAB**

ACIID	TAPID	LOCALID
2 0 0	2 0 0	0
3 0 0	2 0 1	0
3 1 0	2 0 2	1

**Table history****BCS26**

Table TAPIDTAB was introduced in BCS26.

**Additional information**

Restore table TAPIDTAB before you restore the inventory tables of the devices that require ILM resources. These tables are APINV, LIMINV, LIUINV, and NIUINV. Nortel recommends that this table precede table VCHIDTAB.

---

## TARIFF

---

### Table name

TOPS List of Tariff Names Table

### Functional description

Table TARIFF is used to associate a tariff name with a number. This association is used in domestic and overseas rating and charging. Each tariff must be entered in this table before it can be referenced elsewhere.

#### Overseas Operator Center (OOC)

Table TARIFF assigns the numerical value to the tariff name which is subsequently used by call processing to reference that tariff.

*Note:* Each tariff name has a different numerical value.

### Datafill sequence and implications

There is no requirement to datafill other tables prior to table TARIFF.

### Table size

0 to 63 tuples

### Datafill

The following table lists datafill for table TARIFF.

#### Field descriptions

Field	Subfield or refinement	Entry	Explanation and action
VALUE		1 to 63	<p>Tariff number. Enter the tariff number associated with the tariff name.</p> <p>Numbers can be chosen arbitrarily with the restriction that no two tariff names can have the same number and no two numbers can have the same tariff.</p> <p>A maximum of 63 tariffs are allowed.</p> <p>Tariff 0 (zero) is reserved for internal use.</p>
SYMBOL		alphanumeric (up to 32 characters)	<p>Tariff name. Enter the tariff name associated with the above tariff number.</p>

---

**TARIFF** (end)

---

**Datafill example**

Examples of datafill for table TARIFF are shown below.

The first example shows datafill for the North American Traffic Operator Position System (TOPS).

**MAP display example for table TARIFF**

<u>VALUE</u>	<u>SYMBOL</u>
1	BELLONT

The second example shows datafill for the North American Traffic Operator Position System (TOPS).

<u>VALUE</u>	<u>SYMBOL</u>
1	STKITTS1

**Table history****BCS36**

Field NAME was renamed to SYMBOL and the range was increased to 32 characters.

## TAXES

---

### Table name

TOPS Taxes Table

### Overview

Taxes and rounding factors are applied to a call after the basic charge (initial and overtime) and class charges, and any surcharges are calculated.

Three different types of taxes can be applied, for example, federal, state or provincial, and municipal. The three different types of taxes are denoted as TAX1, TAX2, and TAX3 respectively. The tax types can be applied singly or in combination to produce the required treatment. For example, state or provincial and municipal taxes can be combined as the second tax and applied to the charges after the first tax. The tax rate and the method of combination are captured in table TAXES.

Table TAXMAP allows the operating company to specify which tax to apply in each schedule for each tariff.

Table ROUND allows the operating company to specify for each tariff how the charges and taxes are rounded.

### Functional description

Table TAXES is used by the operating company to specify the tax rate and the method of combining taxes for each tariff.

Three types of taxes can be applied, for example federal, state or provincial, and municipal (fields TAX1, TAX2, and TAX3 respectively in table TAXMAP). These taxes can be compounded in table TAXES: field RATE1 is added to charge and then field RATE2 is calculated based on the result. Or, they can be combined: fields RATE1, RATE2, and RATE3 are all calculated based on the charges and then added together to the charges.

### TOPS Mass Table Control

Feature V0178 (TOPS Mass Table Control) permits data changes in table TAXES to be mass-table-controlled. In other words, the feature permits the simultaneous activation of data changes in the table by entering the data changes for the table into table TAXESI, and then, when all the required changes are entered, swap the contents of table TAXES with table TAXESI.

For further information on feature V0178, refer to table CHARGEI.



---

**TAXES** (continued)

---

**Overseas Operator Center (OOC)**

Table TAXES is used to specify the tax rate and the method of combining the taxes for each tariff.

For OOC, table TAXES is used without any changes since table TAXMAP is modified to allow only one tax.

**Caribbean expansion plan (CEP) International TOPS (ITOPS)**

Calls requiring operator assistance result in a charge to the customer that is calculated by a downstream process using the call information (for example, call type, destination, answer time, and duration of call).

There are cases, however, where the charges on a call must be quoted to the customer. This is true for the following call types:

- hotel calls
- coin calls
- calls requiring time-and-charges quote

In all three cases, the International Traffic Operator Position System (TOPS) (ITOPS) calculates the charges on the call. For hotel calls, these charges are reported to the hotel billing center (HOBIC) for quoting; in the latter two cases, the operator quotes the charges.

**CEP dialing plan**

The dialing plan for the Caribbean islands is based on the North American plan (NPA-NXX-XXXX). The islands have numbering plan area (NPA) 809, with each island having one or more unique NXX associated with it.

**CEP ITOPS rating zones**

The following terminology is used within this document to define the different CEP ITOPS rating zones:

**Local Calls** completed within the same rate zone as the calling customer (calls within the same NXX are always considered to be in the local rate zone)

**Domestic Calls** completed within NPA 809 but to an NXX in a different rate zone as the calling customer

**North American Calls** completed from NPA 809 to any destination based on the NPA-NXX dialing plan (other than domestic calls)

## TAXES (continued)

---

**International (or Overseas) Calls** completed from NPA 809 to a foreign country not based on the NPA-NXX dialing plan (outside World Zone 1)

### CEP taxes

To calculate taxes on the call table, table TAXMAP is used to specify up to three different levels of taxation (allowing for taxes by three levels of government) for a given tariff and schedule combination.

Once an entry in table TAXMAP has been found for the tariff and the rate schedule of the call, table Taxes is used to determine the actual tax rates for the tariff. If more than one tax rate applies, there is also the possibility of specifying tax compounding for each level of taxation.

### CEP rounding of charges

Table ROUND is provided to round charges to the nearest whole entity (nickels, for coin calls, pennies for non-coin calls) allowing pre-tax charges, the actual tax amount, as well as the total after-tax charges.

The following information is datafilled in table ROUND:

- pre-tax penny rounding factor, non-coin calls (0 to 9)
- pre-tax nickel rounding, coin calls (Y [yes] or N [no])
- pre-tax nickel rounding factor, coin calls (0 to 49)
- tax 1..3 penny rounding factor, non-coin calls (0 to 9)
- tax 1..3 nickel rounding, coin calls (Y or N)
- tax 1..3 nickel rounding factor, coin calls (0 to 49)
- total charge rounding, coin calls (Y or N)
- total charge rounding factor, coin calls (0 to 49)

The rounding factors are added to the actual amount and the obtained value is then truncated to achieve the required rounding.

## Datafill sequence and implications

The following tables must be datafilled after table TAXES.

- TARIFF
- SSETNAME

## Table size

0 to 64 tuples

**TAXES** (continued)**Datafill**

The following table lists datafill for table TAXES.

**Field descriptions**

Field	Subfield or refinement	Entry	Explanation and action
TARIFF		alphanumeric (up to 32 characters)	Calling tariff key. Enter the calling tariff name. This name must be known to table TARIFF.
RATE1		0 to 817	Tax rate 1. Enter the tax rate, in units of 10, for tax rate 1 (TAX1) as a percentage. For example, enter 7 for 0.7%.
COMP2		Y or N	Compound tax 2. Enter Y (yes) if tax rate 2 (field RATE2) is to be applied to the accumulated charges and taxes. Otherwise, enter N (no) if tax rate 2 is to be applied to the original charge only.
RATE2		0 to 817	Tax rate 2. Enter the tax rate, in units of 10, for tax rate 2 (TAX2) as a percentage. For example, enter 7 for 0.7%.
COMP3		Y or N	Compound tax 3. Enter Y if tax rate 3 (field RATE3) is to be applied to the accumulated charges and taxes. Otherwise, enter N if tax rate 3 is to be applied to the original charge only.
RATE3		0 to 817	Tax rate 3. Enter the tax rate, in units of 10, for tax rate 3 (TAX3) as a percentage. For example, enter 7 for 0.7%.

**Datafill example**

The following example shows sample datafill for table TAXES.

The first example shows datafill for the North American TOPS.

In the example, the call is coin paid, therefore charges and taxes are combined.

TAX1 is calculated at (7% charges) but not added to the charges as yet.

**Note:** A value of 70 in the tax field (field RATE1) represents a tax rate of 7.0%. This allows greater refinement of the tax rates.

**TAXES** (end)

---

Field COMP2 is Y, so TAX2 is calculated (at 10%) of the pretax charges plus TAX1. The result is rounded using TAX2 rounding factor.

Field COMP3 is N, so TAX3 is calculated (at 5%) of the pretax charges, and rounded using TAX3 rounding factor.

The final charge is found by summing the pretax charges plus TAX1 and TAX2 and TAX3.

*Note:* On a hotel call, the charges and taxes are calculated similarly but reported separately.

**MAP display examples for table TAXES**

TARIFF	RATE1	COMP2	RATE2	COMP3	RATE3
BELLONT	70	Y	100	N	50

TARIFF	RATE1	COMP2	RATE2	COMP3	RATE3
STKITTS1					
1	70	N	30	N	0
STKITTS					
2	70	N	30	N	0

---

**TAXESI**

---

**Table name**

TOPS Taxes Inactive Table

**Functional description**

Feature V0178 (TOPS Mass Table Control) permits data changes in table TAXES to be mass-table-controlled. In other words, the feature permits the simultaneous activation of data changes in the table by entering the data changes for the table into table TAXESI, and then, when all the required changes are entered, swap the contents of table TAXES with table TAXESI.

For further information on feature V0178, refer to table CHARGEI.

Refer to table TAXES.

**Datafill sequence and implications**

Refer to table TAXES.

**Table size**

Refer to table TAXES.

**Datafill**

Refer to table TAXES.

# TAXFIX

## Table name

ITOPS Rating Charge Calculator Tax Rates Map Table

## Functional description

Table TAXFIX maps schedule set names into various tax rates when field TAXTYPE in table TAXMAPS is FIX. The taxes are fixed based on the duration and charge rate of the call.

## Datafill sequence and implications

Table TAXMAPS must be datafilled after table TAXFIX.

## Table size

0 to 63 tuples

## Datafill

The following table lists datafill for table TAXFIX.

### Field descriptions (Sheet 1 of 3)

Field	Subfield or refinement	Entry	Explanation and action
TAXSET		1 to 63	Tax set number. The tax set number is a key used by table TAXMAPS.
RBK1		0 to 32767	Rate break 1. Contains the tax rate break 1 value. RBK1 defines a range over which TAX1 is applicable. A call with an initial charge rate (charge/min) greater than 0 (zero), and less than or equal to RBK1, is taxed the TAX1 value.
TAX1		0 to 32767	Tax rate 1. Contains the amount of tax that is applied over RBK1.
RBK2		0 to 32767	Rate break 2. Contains the tax rate break 2 value. RBK2 defines a range over which TAX2 is applicable. A call with an initial charge rate (charge/min) greater than RBK1, and less than or equal to RBK2, is taxed the TAX2 value.
TAX2		0 to 32767	Tax rate 2. Contains the amount of tax that is applied over RBK2.

**TAXFIX** (continued)**Field descriptions (Sheet 2 of 3)**

<b>Field</b>	<b>Subfield or refinement</b>	<b>Entry</b>	<b>Explanation and action</b>
RBK3		0 to 32767	Rate break 3. Contains the tax rate break 3 value. RBK3 defines a range over which TAX3 is applicable. A call with an initial charge rate (charge/min) greater than RBK2, and less than or equal to RBK3, is taxed the TAX3 value.
TAX3		0 to 32767	Tax rate 3. Contains the amount of tax that is applied over RBK3.
RBK4		0 to 32767	Rate break 4. Contains the tax rate break 4 value. RBK4 defines a range over which TAX4 is applicable. A call with an initial charge rate (charge/min) greater than RBK3, and less than or equal to RBK4, is taxed the TAX4 value.
TAX4		0 to 32767	Tax rate 4. Contains the amount of tax that is applied over RBK4.
RBK5		0 to 32767	Rate break 5. Contains the tax rate break 5 value. RBK5 defines a range over which TAX5 is applicable. A call with an initial charge rate (charge/min) greater than RBK4, and less than or equal to RBK5, is taxed the TAX5 value.
TAX5		0 to 32767	Tax rate 5. Contains the amount of tax that is applied over RBK5.
RBK6		0 to 32767	Rate break 6. Contains the tax rate break 6 value. RBK6 defines a range over which TAX6 is applicable. A call with an initial charge rate (charge/min) greater than RBK5, and less than or equal to RBK6, is taxed the TAX6 value.
TAX6		0 to 32767	Tax rate 6. Contains the amount of tax that is applied over RBK6.

**TAXFIX** (end)

**Field descriptions (Sheet 3 of 3)**

Field	Subfield or refinement	Entry	Explanation and action
RBK7		0 to 32767	Rate break 7. Contains the tax rate break 7 value. RBK7 defines a range over which TAX7 is applicable. A call with an initial charge rate (charge/min) greater than RBK6, and less than or equal to RBK7, is taxed the TAX7 value.
TAX7		0 to 32767	Tax rate 7. Contains the amount of tax that is applied over RBK7.
RBK8		0 to 32767	Rate break 8. Contains the tax rate break 8 value. RBK8 defines a range over which TAX8 is applicable. A call with an initial charge rate (charge/min) greater than RBK7, and less than or equal to RBK8, is taxed the TAX8 value.
TAX8		0 to 32767	Tax rate 8. Contains the amount of tax to be applied over RBK8.

**Datafill example**

The following example shows sample datafill for table TAXFIX.

**MAP display example for table TAXFIX**

TAXSET	RBK1	TAX1	RBK2	TAX2	RBK3	TAX3	RBK4	TAX4
	RBK5	TAX5	RBK6	TAX6	RBK7	TAX7	RBK8	TAX8
1	1	2	11	5	45	7	50	13
	75	20	100	27	0	0	0	0



---

**TAXMAP**

---

**Table name**

TOPS Schedule-Taxes Mapping Table

**Functional description**

The operating company uses table TAXMAP to specify which taxes are applicable to any schedule within a tariff.

Three different types of taxes can be applied, for example, federal, state or provincial, and municipal. The three different types of taxes are denoted as TAX1, TAX2, and TAX3 respectively. Within a tariff, different schedules can have different applicable taxes. The different taxes are specified in table TAXMAP.

For related information, refer to table TAXES.

**Tops Mass Table Control**

Feature V0178 (TOPS Mass Table Control) permits data changes in table TAXMAP to be mass-table-controlled. In other words, the feature permits the simultaneous activation of data changes in the table by entering the data changes for the table into table TAXMAPI, and then, when all the required changes are entered, swap the contents of table TAXMAP with table TAXMAPI.

For further information on feature V0178, refer to table CHARGEI.

**Overseas Operator Center (OOC):**

Table TAXMAP is used to specify which of the three taxes are applicable to any schedule within the tariff. The type of applicable taxes are state or provincial, federal, and municipal taxes.

For OOC, table TAXMAP is kept as if to allow all three taxes, but in general only allows datafill for provincial tax.

**Datafill sequence and implications**

The following tables must be datafilled before table TAXMAP:

- TARIFF
- SSETNAME
- SCHNAME

**Table size**

0 to 4096 tuples

**TAXMAP** (continued)**Datafill**

The following table lists datafill for table TAXMAP.

**Field descriptions**

Field	Subfield or refinement	Entry	Explanation and action
TRFSCH		see subfields	TAXMAP key. This field is the key to the table and consists of subfields TARIFF and SCHNAME.
	TARIFF	alphanumeric (up to 32 characters)	Calling tariff. Enter the calling tariff name as previously defined in table TARIFF.
	SCHNAME	alphanumeric (1 to 17 characters)	Schedule name key. Enter the name of the rate schedule as previously defined in table SCHNUM.  The entry in this field cannot be the schedule name associated with schedule number 0 (zero).
TAX1		Y or N	Tax rate 1 applicable. Enter Y (yes) if tax rate 1 (TAX1) is applicable to the schedule for the tariff. Otherwise, enter N (no).
TAX2		Y or N	Tax rate 2 applicable. Enter Y if TAX2 is applicable to the schedule for the tariff. Otherwise, enter N.
TAX3		Y or N	Tax rate 3 applicable. Enter Y if TAX3 is applicable to the schedule for the tariff. Otherwise, enter N.

**Datafill example**

The following examples show sample datafill for table TAXMAP.

The first example shows datafill for the North American Traffic Operator Position System (TOPS).

**TAXMAP** (end)**MAP display example for table TAXMAP**

	TRFSCH	TAX1	TAX2	TAX3
BELLONT	TCTS	Y	N	N

The second example shows datafill for the Caribbean Expansion Plan (CEP) International TOPS (ITOPS).

	TRFSCH	TAX1	TAX2	TAX3
STKITTS1	CANADA	Y	N	N
STKITTS2	WESTEUROPE	Y	Y	N

## **TAXMAPI**

---

### **Table name**

TOPS Schedule-Taxes Mapping Inactive Table

### **Functional description**

Feature V0178 (TOPS Mass Table Control) permits data changes in table TAXMAP to be mass-table-controlled. In other words, the feature permits the simultaneous activation of data changes in the table by entering the data changes for the table into table TAXMAPI, and then, when all the required changes are entered, swap the contents of table TAXMAP with table TAXMAPI.

For further information on feature V0178, refer to table CHARGEI.

Refer to table TAXMAP.

### **Datafill sequence and implications**

Refer to table TAXMAP.

### **Table size**

Refer to table TAXMAP.

### **Datafill**

Refer to table TAXMAP.

### **Datafill example**

Refer to table TAXMAP.

**TAXMAPS****Table name**

ITOPS Rating Charge Calculator Schedule-Taxes Mapping Table

**Functional description**

Table TAXMAPS controls the type of tax that is applied to a schedule within an SSETNAME. The tax type is either FIXED or RATE.

In addition to specifying the taxing method, this table enables taxes to be charged that are based on either pre-modified (before discounts or surcharges are applied) or post-modified charges. Within a SSETNAME, different schedules can have different applicable taxes.

**Datafill sequence and implications**

The following tables must be datafilled before table TAXMAPS:

- SCHNAME
- SSETNAME

**Table size**

0 to 4096 tuples

**Datafill**

The following table lists datafill for table TAXMAPS.

**Field descriptions (Sheet 1 of 2)**

Field	Subfield or refinement	Entry	Explanation and action
INDEX		see subfields	Schedule set, schedule key. This field contains subfields SSETNAME and SCHNAME.
	SSETNAME	alphanumeric (1 to 16 characters)	Schedule set name. Contains the calling schedule set name that has been datafilled in table SSETNAME.
	SCHNAME	alphanumeric (1 to 16 characters)	Schedule name. Contains the name of the rate schedule that has been datafilled in table SCHNAME.

**TAXMAPS** (end)

**Field descriptions (Sheet 2 of 2)**

Field	Subfield or refinement	Entry	Explanation and action
MODTYPE		POSTMOD or PREMOD	Charge modification type. POSTMOD indicates that taxes are applied to the post-modified (after surcharges or discounts) call charges. PREMOD indicates that taxes are applied to pre-modified charges.
TAXTYPE		FIX or RATE	Tax method applied. FIX indicates that fixed tax charges are applied, as specified in table TAXFIX. RATE indicates that taxes are based on the total call charge, as specified in table TAXRATE.
TAXSET		1-63	Mapping index for tables taxrate and taxfix. Contains the mapping index for tables TAXRATE and TAXFIX.

**Datafill example**

The following example shows sample datafill for table TAXMAPS.

**MAP display example for table TAXMAPS**

INDEX				
SSETNAME	SCHNAME	MODTYPE	TAXTYPE	TAXSET
SCHSETA	SCHED1	PREMOD	RATE	1

**TAXRATE****Table name**

ITOPS Rating Charge Calculator Tax Rates Table

**Functional description**

Table TAXRATE is used, when table TAXMAPS field TAXTYPE = RATE, to map schedule set names into various tax rates for taxes based on the entire call charge.

Table TAXRATE is used to specify for each tax set three different tax rates (federal, state or provincial, and municipal, for example) and whether the second and third tax rates are to be compounded or not.

Following the tax calculations the system proceeds to table RNDING for rounding.

For related information, refer to table ATRIMOD.

**Datafill sequence and implications**

There is no requirement to datafill other tables prior to table TAXRATE.

**Table size**

0 to 63 tuples

**Datafill**

The following table lists datafill for table TAXRATE.

**Field descriptions (Sheet 1 of 2)**

Field	Subfield or refinement	Entry	Explanation and action
TAXSET		1 to 63	Tax set. Enter a tax set number. This number is a key used by table TAXMAPS
RATE1		0 to 100	Tax rate 1. Enter the percentage tax rate 1 to be applied to the pretax charges.
COMP2		Y or N	Compound tax 2. Enter Y if tax rate 2 is to be applied to the accumulated charges and taxes. Otherwise, enter N if tax rate 2 is to be applied to the original charge only.
RATE2		0 to 100	Tax rate 2. Enter the percentage tax rate 2 to be applied.

---

## TAXRATE (end)

---

### Field descriptions (Sheet 2 of 2)

Field	Subfield or refinement	Entry	Explanation and action
COMP3		Y or N	Compound tax 3. Enter Y if tax rate 3 is to be applied to the accumulated charges and taxes. Otherwise, enter N if tax rate 3 is to be applied to the original charge only.
RATE3		0 to 100	Tax rate 3. Enter the percentage tax rate 3 to be applied.

### Datafill example

The following example shows sample datafill for table TAXRATE.

#### MAP display example for table TAXRATE

TAXSET	RATE1	COMP2	RATE2	COMP3	RATE3
1	5	Y	6	Y	7



---

**TCAPTRID**

---

**Table name**

TCAP Transaction Identifier Table

**Functional description****ATTENTION**

Feature 59014752 (TCAPTRID Removal) obsoletes table TCAPTRID. Identifier pools (IDPL) automatically allocate transaction and component identifiers for all applications.

Table TCAPTRID continues to be visible. However, during the One-Night Process (ONP), the system sets the values for transaction and component identifiers to zero, and the value for field IDPLUSER to Y. As a result, all applications obtain their transaction IDs from IDPLs.

You cannot create or change any datafill in table TCAPTRID.

If you try to add a tuple in table TCAPTRID, the system displays the following message:

```
Applications no longer engineer TCAP transaction and
component Ids in table TCAPTRID. They are dynamically
allocated by Identifier Pool software.
```

If you try to change a tuple in table TCAPTRID, the system displays the following message:

```
Application has converted to Identifier Pool
Software. Modification of this tuple is not allowed.
```

*Note:* You can still delete tuples from table TCAPTRID. Nortel Networks recommends that you delete all tuples after the ONP.

**Datafill sequence and meaning**

Does not apply.

**Table size**

Does not apply.

**TCAPTRID** (continued)**Datafill**

Do not add or change any tuples.

**Field descriptions**

Field	Subfield	Entry	Explanation and action
TCAPAPPL		ACBAR, AIN, CNAMD, DNVAL, INAP, MAPMSC, NACD, NMS, NRAG, NSSTCN, OLNS, PVN, REPLDIGS, RTRS, or SIGTRANS	<i>Transaction capabilities application</i> Do not enter or change any values in this field.
NUMTRIDS		numeric (0 to 32 767)	<i>Number of transaction identifiers</i> The default value is 0. Do not change the value for this field.
NUMCOMPS		numeric (0 to 32 767)	<i>Number of component identifiers</i> The default value is 0. Do not change the value for this field.
IDPLUSER		Y or N	<i>Identifier pools in use</i> The default value is Y. IDPLs dynamically allocate the TCAP transaction and component identifiers for the application. Do not change the entry for this field.

**Datafill example**

Sample datafill for table TCAPTRID appears in the following example.

**TCAPTRID** (continued)**MAP example for table TCAPTRID**

TCAPAPPL	NUMTRIDS	NUMCOMPS	IDPLUSER
PVN	0	0	Y
ACBAR	0	0	Y
NACD	0	0	Y
DNVAL	0	0	Y
NMS	0	0	Y
FREEPHONE	0	0	Y
AIN	0	0	Y
CNAMD	0	0	Y

**Table history****TL13**

Table TCAPTRID obsoleted.

**NA011**

Added information about changes to AIN and INAP applications. Changed MAP example.

**NA009**

Entry CNAMD in field TCAPAPPL was updated for ISDN Primary Rate Interface (PRI) Calling Name Delivery (I-CNAMD) in NA009.

**NA008**

The TCAP TRID formula was changed for AIN Essentials, AIN Service Enablers, and local number portability (LNP) in NA008. These changes occurred in accordance with the method that Bob Englehart and Susan Bohme (7L16) use. Note this change patches back to NA007 for AIN Essentials.

**APC08**

Entry INAP was added in field TCAPAPPL for the INAP protocol in APC08.

**TL08**

Field IDPLUSER was added in TL08.

**TL05**

Value OLNS was added to field TCAPAPPL according to OLNS TCAP and AMA Changes in TL05.

## **TCAPTRID** (end)

---

### **TOPS04**

Value RTRS was added to field TCAPAPPL for each feature AN1389 in functionality External RTRS Interface, ENSV0009 in TOPS04.

### **BCS36**

The total NUMTRIDS for all applications was changed in the "Table size section" and field NUMTRIDS. Reference to the NORESTARTSWACT utility was added in BCS36.

**TCLG7DIG****Table name**

TOPS Calling Seven Digit Number

**Functional description**

Table TCLG7DIG is used with the enhanced billing code method to expand a 7-digit calling number to ten digits by appending the NPA. This table is only accessed for 7-digit expansion if table ISUPTRK or TRKGRP has field BCTYPE = ENHBC. Then, if a trunk is not in table TCLG7DIG, the SNPA is taken from table TRKGRP or ISUPTRK field SNPA. This hierarchy is used to indicate NXXs that require a different SNPA than is in table TRKGRP.

Individual trunk groups could be switched to use this table by changing the BILLCD subfield BCTYPE to ENHBC on the trunk group.

**Datafill sequence and implications**

Tables TRKGRP and HNPACONT (or SNPANAME) must be datafilled before table TCLG7DIG.

**Table size**

8 K trunk groups X 1000 bill codes = 8 M tuples

**Datafill**

The following table lists datafill for table TCLG7DIG.

**Field descriptions**

Field	Subfield or refinement	Entry	Explanation and action
TCLG7KEY		see subfield	TOPS calling number 7-digit key. This field is the key to the table and consists of subfields CLLI and NXX.
	CLLI	name from TRKGRP	Common language location identifier. Enter a TOPS trunk previously defined in table TRKGRP.
	NXX	000 to 999	Billing code NXX of the calling party. Enter a billing code NXX that requires a different SNPA than is in table TRKGRP field SNPA.
SNPA		value from HNPACONT or SNPANAME	Serving numbering plan area. Enter the SNPA that is used to expand the 7-digit ANI to 10 digits. The entry must be previously defined in table HNPACONT.

## TCLG7DIG (end)

---

### Datavfill example

The following example shows sample datavfill for table TCLG7DIG.

### MAP display example for table TCLG7DIG

CLLI	NXX	SNPA
TBELLIC1	320	919
TBELLIC1	322	619
TBELLIC2	320	813

### Table history

#### TOPS10

This table was created by feature AF7498 in functionality TOPS BC/STS/SNPA, OSB00001.

**TCLGVER****Table name**

TOPS Calling Number Verification

**Functional description**

Table TCLG7VER is used for verification of the calling NXX billing code. This table contains all valid NPA-NXXs for a given trunk group. This table is accessed only if table TRKGRP or ISUPTRK has field CLGVER = Y. Verification is performed after 7 to 10 digit expansion so the calling number is guaranteed to be 10 digits. If CLGVER = N, table TCLGVER is not accessed and all calling numbers are accepted.

Individual trunk groups could be switched to use this table by changing the BILLCD subfield BCTYPE to ENHBC on the trunk group.

**Datafill sequence and implications**

Tables TRKGRP and HNPACONT (or SNPANAME) must be datafilled before table TCLGVER.

**Table size**

8 K trunk groups X 1000 bill codes = 8 M tuples

**Datafill**

The following table lists datafill for table TCLGVER.

**Field descriptions (Sheet 1 of 2)**

Field	Subfield or refinement	Entry	Explanation and action
GRPKEY		see subfield	Group key. This field is the key to the table and consists of subfields CLLI and NXX.

## TCLGVER (end)

### Field descriptions (Sheet 2 of 2)

Field	Subfield or refinement	Entry	Explanation and action
	CLLI	name from TRKGRP	Common language location identifier. Enter a TOPS trunk previously defined in table TRKGRP.
	NPANXX	6 digits	Billing code NPA-NXX of the calling party. Enter a valid NPA-NXX for this trunk group. The NPA does not have to be previously defined in table HNPACONT nor SNPANAME. There must be a tuple for each NPA-NXX on this trunk group. The NXX billing codes include the following: <ul style="list-style-type: none"> <li>• all central office NXX codes</li> <li>• special billing codes</li> <li>• wide area telephone service (WATS) originating codes that are allowed to originate direct distance dialing (DDD) calls over the trunk group</li> </ul>

### Datavfill example

The following example shows sample datafill for table TCLGVER.

### MAP display example for table TCLGVER

```

GRPKEY
-----
TBELIC1  619320
TBELIC1  619322
TBELIC2  619320
    
```

### Table history

#### TOPS10

This table was created by feature AF7498 in functionality TOPS BC/STS/SNPA, OSB00001.



---

## TDBCLASS

---

**Table name**

TOPS Database Class Table

**Functional description**

Table TDBCLASS contains information for restricted and special delivery numbers. Data fields in table TDBCLASS closely resemble data fields in table SPLDNID.

For related information, refer to tables TOPSDB and DNSCRN.

**Datafill sequence and implications**

The following tables must be datafilled before table TDBCLASS:

- TOPSDEV
- HOBICDEV

Table TDBCLASS is a fixed-size table. Tuples in the table cannot be deleted if they are referenced by table TOPSDB.

**Table size**

0 to 1001 tuples

**Datafill**

The following table lists datafill for table TDBCLASS.

**Field descriptions (Sheet 1 of 5)**

Field	Subfield or refinement	Entry	Explanation and action
IDX		0 to 1000	Index. This field is the key to the table. Enter the table index. The entry in this field is referenced by table TOPSDB.
TDBCLSEL		see subfield	Traffic Operator Position System database control selector. This field consists of subfield SEL.

**TDBCLASS** (continued)**Field descriptions (Sheet 2 of 5)**

<b>Field</b>	<b>Subfield or refinement</b>	<b>Entry</b>	<b>Explanation and action</b>
	SEL	APSLOG, AQHTL AQTAC COIN DUAQHTL DUAQTAC NOSPLDNID RSTRCTD VQHTL	<p>Selector. Enter APSLOG for attendant pay station log and datafill refinements APSLOG_NUM and NC as described below.</p> <p>Enter AQHTL for auto-quote hotel teletype (TTY) and datafill refinements DUAQ_NUM and NC.</p> <p>Enter AQTAC for auto-quote time-and-charge TTY and datafill refinement AQ_NUM.</p> <p>Enter COIN for coin phone and datafill refinements LC_TYPE, ACTS_COMPATABLE, RESCOIN, and RBILCLAS.</p> <p>Enter DUAQHTL for dial-up auto-quote hotel TTY and datafill refinements DUAQ_NUM and NC.</p> <p>Enter DUAQTAC for dial-up auto-quote time-and-charge TTY and datafill refinement DUAQ_NUM.</p> <p>Enter NOSPLDNID for nil value. No refinements require datafill.</p> <p>Enter VQHTL for voice-quote hotel TTY and datafill refinement NC.</p> <p>Enter RSTRCTD for restricted billing class and datafill refinement RBILCLAS.</p> <p>Values AQTAC and DUAQTAC can only be datafilled if field ARAN = N or if ARAN = Y and ARANVAL= INSTN.</p>
	APSLOG_NUM	0 to 21	APS log number. This field indicates the log number in log APSLOGxx, where xx is the field entry.
	AQ_NUM	0 to 9999	Auto-quote device number. If the entry in subfield SEL is AQTAC or AQHTL, datafill this refinement. Enter the device number for the auto-quote TTY associated with this directory number (DN). Valid entries must be previously datafilled in table TOPSDEV.

**TDBCLASS** (continued)

## Field descriptions (Sheet 3 of 5)

Field	Subfield or refinement	Entry	Explanation and action
	DUAQ_NUM	0 to 9999	Dial-up auto-quote device number. If the entry in subfield SEL is AQHTL or DUAQHTL, datafill this refinement. Enter the device number for the dial-up auto-quote TTY associated with this directory number (DN). Valid entries must be previously datafilled in table HOBICDEV.
	NC	Y or N	No charge. If the entry in subfield SEL is APSLOG, AQHTL, DUAQHTL, or VQHTL, datafill this refinement. Enter Y to record all calls, charge and no charge. No charge calls have no charge or tax on the record. Enter N to record only charge calls. This field does not apply to no answer, no duration calls.
	LC_TYPE	SPL or STD	Local rate calling type. If the entry in subfield SEL is COIN, datafill this refinement. Enter SPL for special coin type. The associated non-standard schedule name and rate step used is datafilled in table LCLRS.  Enter STD for standard coin type. The associated standard schedule and rate step used is datafilled in table LCLRS.
	ACTS_ COMPATABLE	ACTS or NOACTS	Automatic Coin Toll Service compatible. If the entry in subfield SEL is COIN, datafill this refinement. Enter SPL for special coin type. Enter ACTS if the coin phone is Automatic Coin Toll Service (ACTS) compatible. Otherwise, enter NOACTS (not ACTS compatible).
	RESCOIN	Y or N	Restricted coin line. If the entry in subfield SEL is COIN, datafill this refinement. Enter SPL for special coin type. Enter Y if the line is a restricted coin line. Otherwise, enter N.
	RBILCLAS	0 to 100	Restricted billing class. If the entry in subfield SEL is COIN or RSTRCTD, datafill this refinement. Enter SPL for special coin type. Enter the restricted billing class index into table RESTBIL or table DARSTBIL. If the entry in refinement RESCOIN is N, enter 100.

**TDBCLASS** (continued)**Field descriptions (Sheet 4 of 5)**

<b>Field</b>	<b>Subfield or refinement</b>	<b>Entry</b>	<b>Explanation and action</b>
ARANSEL	ARAN	N or Y	<p>Automated Room and Authorization Number. This field enables (Y) or disables (N) ARAN. If ARAN = N, the call is sent to an operator for room number collection. If ARAN = Y, datafill refinement ARANVAL.</p>
	ARANVAL	HOTELRM, HOTELAUT H, or INSTN	<p>ARAN value. Datafill this field only if field ARAN = Y. This field identifies the ARAN subscriber:</p> <ul style="list-style-type: none"> <li>• HOTELRM - Hotel subscriber, automated room number collection.</li> <li>• HOTELAUTH - Hotel subscriber, automated authorized room number collection.</li> <li>• INSTN - Institution. Only non-coin calls can be classed as institution calls.</li> </ul>
EAANI		Y or N	<p>Equal access automatic number identification. Enter Y to modify automatic number identification (ANI) to carrier and datafill refinement EAANIVAL. Modified ANI spill is used. Otherwise, enter N. Standard ANI spill is used.</p> <p>If the switch is an equal access switch, enter Y. If the switch is not an equal access switch, enter N.</p>

**TDBCLASS** (continued)

## Field descriptions (Sheet 5 of 5)

Field	Subfield or refinement	Entry	Explanation and action
	EAANIVAL	ALARM ANIFAIL ANISUCC FGDCOIN HANIFAIL HANISUCC ILRSHOT ILRSREG ILRSSPEC INTCPT MOBILE ONI OPRHNDL or SPECIAL	<p>Equal access automatic number identification value. If the entry in field EAANI is Y, datafill this refinement. This field indexes table EAANIID. Enter one of the following equal access ANI values:</p> <ul style="list-style-type: none"> <li>• ALARM (alarm)</li> <li>• ANIFAIL (ANI failure)</li> <li>• ANISUCC (ANI successful)</li> <li>• FGDCOIN (feature group D coin)</li> <li>• HANIFAIL (hotel ANI failure)</li> <li>• HANISUCC (hotel ANI successful)</li> <li>• ILRSHOT (inter-LATA [local access and transport area] restricted hotel)</li> <li>• ILRSREG (inter-LATA restricted regular)</li> <li>• ILRSSPEC (inter-LATA restricted special)</li> <li>• INTCPT (intercept)</li> <li>• MOBILE (mobile)</li> <li>• ONI (operator number identification)</li> <li>• OPRHNDL (operator handled)</li> <li>• SPECIAL (special)</li> </ul>
BLKCLI		Y or N	Block Calling Line Identifier. This field indicates if the calling line identifier (calling number) should be blocked, based on the directory number for MF to ISUP calls. Blocking on a trunk group basis is available in table ISUPTRK. Blocking overrides forwarding of CLI in tables TOPSTOPT, ISUPTRK, and TOPSPARM.

**Datafill example**

The following example shows sample datafill for table TDBCLASS.

**TDBCLASS** (continued)**MAP display example for table TDBCLASS**

IDX	TDBCLSEL	ARANSEL		EAANI	BLKCLI	
0	NOSPLDNID		N	N	N	
2	VQHTL	N	Y	HOTELRM	N	N
3	AQHTL	Y	Y	HOTELAUTH	N	N
4	AQTAC 3	Y		INSTN	N	N
5	DUAQTAC 1		N		N	N

The above datafill indicates the following:

- **IDX: 0** - this is the default tuple
- **IDX: 2**
  - HOBIC recording by VQHTL
  - no HOBIC record generated and room number not collected for alternately billed calls - These calls go directly to AABS.
  - automation, if ARAN\_STATUS is either HOTEL or BOTH
  - hotel subscriber, room number collection
- **TDBIDX: 3**
  - HOBIC recording by AQHTL
  - HOBIC record generated for alternately billed calls
  - automation, if ARAN\_STATUS is either HOTEL or BOTH
  - hotel subscriber, authorization number collection
- **TDBIDX: 4**
  - HOBIC recording by AQTAC (institution only device)
  - automation, if ARAN\_STATUS is either INSTN or BOTH
  - institution subscriber - Always collect authorization number.
- **TDBIDX: 5**
  - HOBIC recording by AQTAC
  - no ARAN functionality
  - Note, ARAN generates HOBIC records for all 1+ hotel and 1+ institution calls.

**TDBCLASS** (end)**Error messages**

The following error messages apply to table TDBCLASS.

**Error messages for table TDBDCLASS**

Error message	Explanation and action
Tuple 39 is not datafilled in table TDBCLASS.	Table TDBCLASS is referenced by table TOPSDB and must be datafilled prior to table TOPSDB. If the craftsperson attempts to add or change a table TOPSDB tuple with a given TDBCLIDX prior to adding the tuple to table TDBCLASS, the add or change is not allowed, and an error message is given.

**Table history****NA009**

Field SEL has new value APSLOG by feature AF7161 in functionality Attendant Pay Station, OSB00001.

**NA006**

Field ARANSEL is now generally available by feature AN0819 in functionality Automated Room and Authorization Number, ABS00009.

**NA005**

Added field BLKCLI per functionality GR317/GR394 ISUP to/from TOPS, OSEA0005.

**TOPS03**

Added proprietary field ARANSEL.

**BCS36**

Table TDBCLASS was introduced.

**Supplementary information**

This section provides information on dump and restore procedures for table TDBCLASS.

**Dump and restore**

Normal dump and restore procedures apply.





---

## TDBDAOPT

---

### Table name

TOPS Database Directory Assistance Options

### Functional description

Table TDBDAOPT contains restrictions for Automatic Directory Assistance Call Completion (ADACC). The fields of the table indicate which LATA statuses may be offered ADACC, and which billing options are available for ADACC.

Tuple 0 is the default and allows ADACC for all LATA statuses and all billing options.

### Datafill sequence and implications

Table TDBDAOPT is referenced by table TOPSDB and must be datafilled prior to table TOPSDB.

Tuples in the table cannot be deleted if they are referenced by table TOPSDB.

Default tuple 0 cannot be changed or deleted.

### Table size

0 to 1000 tuples.

Table TDBDAOPT is a fixed-size table.

**TDBDAOPT** (continued)**Datafill**

The following table lists datafill for table TDBDAOPT.

**Datafilling table TDBDAOPT**

<b>Field</b>	<b>Subfield or refinement</b>	<b>Entry</b>	<b>Explanation and action</b>
TDBDAIDX		0 to 1000	TOPS database directory assistance index. This is the table key and is indexed from table TOPSDB. Default tuple 0 is shown in the following datafill example and cannot be changed or deleted.
ADACCSRV		Set of {INTRALCL, INTRATOLL, INTER, OVERSEAS}, ALL, or NONE	Automatic directory assistance call completion service. This field indicates the LATA status that ADACC can be offered. The values are as follows: <ul style="list-style-type: none"> <li>• INTRALCL - local ADACC only</li> <li>• INTRATOLL - non-local INTRA toll ADACC</li> <li>• INTER - long distance toll ADACC</li> <li>• OVERSEAS - international ADACC calls</li> <li>• ALL - INTER, INTRATOLL, and INTRALCL</li> <li>• NONE - ADACC is not available</li> </ul>
BILLOPT		Set of {CONTBIL, SENTPD, ALTBIL, OPERBIL}, ALL, or NONE	Set of valid billing options for the call completion portion of an ADACC call. The values are described below.

**TDBDAOPT** (continued)**Datafilling table TDBDAOPT**

Field	Subfield or refinement	Entry	Explanation and action
		ALL	<p>ALL (all billing types).</p> <p><b>Note:</b> The information in field BILTYPES is passed to the NT Directory Assistance system, and is used for building the appropriate ADACC announcements for automated playback to the caller. In TOPS03, value OPERBIL was added to this field. Value OPERBIL is not recognized by the ADACC announcement software as a valid billing option, and building of the announcement fails if this value is received by the announcement subsystem. Therefore, for TOPS03 and up, values ALL and OPERBIL should not be used. Instead, only values CONTBIL, SENTPD, and ALTBIL should be used. If ALL is datafill prior to the TOPS03 upgrade, change to the values CONTBIL, SENTPD, and ALTBIL (excluding OPERBIL).</p>
		ALTBIL	<p>ALTBIL (alternate billing). Caller desires to bill call completion charges either to a calling card, to a third number, or collect.</p>
		CONTBIL	<p>CONTBIL (continue billing). Call completion charges billing must use billing method already established for DA portion of call.</p> <p><b>Note:</b> CONTBIL is valid only if the preceding DA call was billable which insures that a valid billing method was established. If the billing method established for the DA call was bill to third party, then the entry in office parameter DACC_BILL_TO_THIRD in table VROPT determines if the CONTBIL option can be selected for call completion. If office parameter DACC_BILL_TO_THIRD in table VROPT contains N, CONTBIL is not an option offered to the subscriber.</p>

**TDBDAOPT** (continued)

**Datafilling table TDBDAOPT**

Field	Subfield or refinement	Entry	Explanation and action
		NONE	<p>NONE (none). Retain billing method used prior to this alternate billing feature. The subscriber is not offered a selection of billing options for call completion.</p> <p><b>Note:</b> Use of this value is changed by feature AN0262 in TOPS03. Refer to the history section for the functionality of this feature. Prior to AN0262, or if feature AN0262 is not active, specifying NONE indicates that the subscriber is not offered a selection of billing options for call completion, and that the billing approach used prior to Feature AF2086 (ADACC with Alternate Billing) is to be used. When feature AN0262 is active, value NONE indicates that no billing types are valid, except auto-collect. It is suggested that all instances of NONE be changed to either CONTBIL or SENTPD before activating feature AN0262.</p> <p>NONE is still a valid entry but its use changed in TOPS03.</p>
		SENTPD	SENTPD (sent paid). Call completion charges are billed to the calling party.
		OPERBIL	OPERBIL (operator billing). The subscriber is connected to a toll operator for billing the ADACC call. This value should not be used. For further information, see the note under value ALL for this field.
ADASERV		N or Y	ADAS service. This field indicates if the incoming DN may use ADAS or ADAS+. The default is Y. This field is only used during DN screening. If set to Y, the subscriber is given automated DA service. If the subscriber desires a live operator, enter N.

**Datafill example**

The following example shows sample datafill for table TDBDAOPT.

**TDBDAOPT** (continued)**MAP display example for table TDBDAOPT**

TDBDAIDX	ADACCSRV	BILLOPT	ADASERV
0	ALL	ALL	Y
1	BLOCK		Y
3	ALL	CONTBIL OPERBIL \$	N
4	INTRA	SENTPD \$	N
5	ALL	OPERBIL SENTPD \$	Y
6	INTER	ALL	Y
7	INTER	ALTBIL CONTBIL \$	Y

Tuple 0 is the default tuple for DNs without an entry in table DNSCRN. Therefore, subscribers are sent to the ADAS system (field ADASERV=Y) if they have not specified otherwise.

**Error messages**

The following error messages apply to table TDBDAOPT.

**Error messages for table TDBDAOPT**

Error message	Explanation and action
Tuple 39 is not datafilled in table TDBDAOPT.	Table TDBDAOPT is referenced by table TOPSDB and must be datafilled prior to table TOPSDB. If the craftsperson attempts to add or change a table TOPSDB tuple with a given TDBDAOPT prior to adding the tuple to table TDBDAOPT, the add or change is not allowed, and an error message is given.
Tuple referred to by another table - use TABREF to get potential table list.	If the craftsperson attempts to delete a table TDBDAOPT tuple which is referenced by table TOPSDB, the deletion is not allowed, and an error message is given.
Tuple 0 cannot be deleted or changed.	If the craftsperson attempts to change or delete default tuple 0, the change or deletion is not allowed, and an error message is given.

## **TDBDAOPT (end)**

---

### **Table history**

#### **SN07 (DMS)**

Entry OVERSEAS added to the range of field ADACCSRV by feature A00002740, TOPS International Directory Assistance Call Completion.

#### **TOPS14**

Field ADACCSRV, value INTRA is replaced by INTRATOLL and INTRALCL. Subfields BILLOPT and ADASERV are made full fields. These changes are made by feature 59021116 in functionality DACC Enhancements I, OSDA0102.

#### **TOPS07**

Field ADASPLUS is renamed ADASERV since it is now applicable to both ADAS and ADAS+. This change is made by feature AF6544 in functionalities ADAS (OSDA0004) and DA Automation I/F (OSDA0006).

#### **TOPS03**

Feature AN0262 in Cellular/IXC/LEC ADACC, OSDA0005:

- Introduced table

Feature AN0880 in DA Automation I/F, OSDA0006:

- Added field ADASPLUS

## TDBNORM

### Table name

TOPS Database Normalization Data Table

### Functional description

Table TDBNORM provides normalization data for R2 signaled calls. Normalization is the mapping of R2 signaling data into the North American TOPS framework for interworking of R2 signaling on TOPS trunks.

Tuple 0 is a default entry that cannot be changed or deleted.

### Datafill sequence and implications

Table TDBNORM must be datafilled before table TOPSDB.

### Table size

1 to 32766 tuples

### Datafill

The following table lists datafill for table TDBNORM.

#### Field descriptions (Sheet 1 of 2)

Field	Subfield or refinement	Entry	Explanation and action
INDEX		0 to 1000	Index. Key Field. This is the index datafilled in table TOPSDB. Value 0 is a default tuple that cannot be changed or deleted.
CALLORIG		from table TOPS	Call Origination. Enter a call origination type defined in table TOPS.
CALLSRC		ORIG, TERM, OPER	Call Source Type. Defines the call as an origination, a termination, or an operator call.
NOAMA		NIL, ORIG, TERM, MANUAL	AMA Type. Identifies whether or not to bill the call: <ul style="list-style-type: none"> <li>• NIL: Bill the call.</li> <li>• ORIG: Do not bill the call. Call billed at the originating office.</li> <li>• TERM: Do not bill the call. Call billed at the terminating office.</li> <li>• MANUAL: Do not bill the call. Call manually billed.</li> </ul>

**TDBNORM** (continued)**Field descriptions (Sheet 2 of 2)**

Field	Subfield or refinement	Entry	Explanation and action
OVRXLACO		Y or N	Override Translation Call Origination. Specifies whether or not to override the call origination obtained by translations, if present (in cases where a T selector is used to route the call).
ANIFAIL		ANIF or ONI	ANI Failure. This field determines whether an ANI fail call will be presented to the operator as an ANIF or an ONI call.
CALLSERV		UNKNOWN, NCN, HTL, CN, FIRM_NCN, FIRM_HTL, FIRM_CN, FIRM_ RESTRICTED, OOC_MOBILE, OOC_MARINE	Calling Service Type. Defines the service of the calling party.
RBIL		Y or N	Restricted Billing. Enter Y to access restricted billing information to provide for the call. Then datafill subfield RBILVAL. Otherwise, enter N if not using restricted billing, and subfield RBILVAL datafill is not required.
	RBILVAL	0 to 100	Restricted Billing Value. This value is used to index into table RESTBIL.

**Datafill example**

The following example shows sample datafill for table TDBNORM.

**MAP display example for table TDBNORM**

INDEX	CALLORIG	CALLSRC	NOAMA	OVRXLACO	ANIFAIL	CALLSERV	RBIL
0	UNSPEC	ORIG	NIL	N	ANIF	NCN	N
1	OA	ORIG	NIL	N	ANIF	NCN	N

In the above example, tuple is the default.



## **TDBNORM** (end)

---

### **Table history**

#### **NA005**

New field RBIL added by PRS MX51957 in functionality R2 on TOPS, GOS00001.

#### **TOPS04**

Table introduced by feature AN1228 in functionality R2 on TOPS, GOS00001.

**TDBSERV****Table name**

TOPS Database Services Table

**Functional description**

Table TDBSERV defines services and the attributes of those services. This table is indexed from table TOPSDB.

Tuple 0 is a default entry that cannot be changed or deleted.

**Datafill sequence and implications**

Table TDBSERV must be datafilled before table TOPSDB.

**Table size**

1 to 1000 tuples

**Datafill**

The following table lists datafill for table TDBSERV.

**Field descriptions (Sheet 1 of 2)**

Field	Subfield or refinement	Entry	Explanation and action
INDEX		1 to 1000	Index. Key Field. This is the index datafilled in Table TOPSDB.
SERVLIST		see subfield	Service List. This field consists of subfield OPTION and refinements.
	OPTION	AABS, ACCS, OPER	Option. For operator service, enter OPER. No other refinements are required.  For Automatic Calling Card Service or Automated Alternate Billing Service, enter ACCS or AABS, respectively. Then, datafill subfields BILTYPES, FWDLANG, and BCKLANG for either service (ACCS or AABS).

**TDBSERV** (continued)

## Field descriptions (Sheet 2 of 2)

Field	Subfield or refinement	Entry	Explanation and action
	BILTYPES	PAID, COL, CC, 3RD, SPLCLG, SPLCLD, ALL, NONE	<p>Billing Types. Defines a set of valid billing options for the service. Table RESTBILL is checked for any restrictions. Also, for ACCS, ACCS must be turned on for the trunk in table MCCSOST. Or, for AABS, AABS must be turned on for the trunk in table AABOST. The billing types are defined as follows:</p> <ul style="list-style-type: none"> <li>• PAID - Sent paid, i.e. billed to the calling station.</li> <li>• COL - Collect and AUTOCOL for automatic collect</li> <li>• CC - Calling credit card</li> <li>• 3RD - Calling third-number billing</li> <li>• SPLCLG - Calling special billing</li> <li>• SPLCLD - Called special billing</li> <li>• ALL - All billing types (PD, COL, CC, 3RD, SPLCLG, SPLCLD)</li> <li>• NONE - No billing types</li> </ul>
	FWDLANG	calling language from table TOPSLANG (up to 3 characters)	Forward Language. Identifies the forward (calling) party language for the service. The language must be defined in table TOPSLANG and marked as AUTOLANG. There is no checking when datafilling this field. If a language is not datafilled, then a nil value is sent to the applicable service (AABS or ACCS).
	BCKLANG	called language from table TOPSLANG (up to 3 characters)	Back Language. Identifies the back (called) party language for the service. The language must be defined in table TOPSLANG and marked as AUTOLANG. There is no checking when datafilling this field. If a language is not datafilled, then a nil value is sent to the applicable service (AABS or ACCS).

---

**TDBSERV** (end)

---

**Datafill example**

The following example shows sample datafill for table TDBSERV.

**MAP display example for table TDBSERV**

INDEX	SERVLIST
0	(AABS COL \$ SPA SPA)

**Table history****TOPS04**

Table introduced by feature AN1228 in functionality R2 on TOPS, GOS00001.

## TDCDEF

---

### Table name

TOPS Message Switch Data Channel Definition

### Functional description

Table TDCDEF allows a TOPS Message Switch (TMS) to define a set of parameters for the TMS Data Channel (TDC). The parameters include protocol, device, device version, and PVC layout configuration type. The protocol is based on the noise conditions of the channel. Devices include the TMS related nodes DA, ORDB, and TPC.

Table TDCDEF has been created to provide TDC channel data that no longer fits into table DCHINV or ISGDEF. Feature AL0956 has made a change to these tables that does not allow all the TDC channel data that is needed for TMS to fit into DCHINV or ISGDEF. Currently, the rate and inversion are in table ISGDEF. The protocol parameter, device and version are in TDCDEF.

Table TDCDEF allows TMS to define a set of parameters for the TMS Data Channel (TDC). The parameters include protocol, device, and device version. The protocol is based on noise conditions for the channel. Devices include TMS-related nodes DA, ORDB, and TPC.

### Datafill sequence and implications

Table SPECCONN must be datafilled after table TDCDEF.

The following tables must be datafilled before table TDCDEF:

- ISGDEF
- TMSPVC

### Table size

0 to 255 tuples

**TDCDEF** (continued)**Datafill**

The following table lists datafill for table TDCDEF.

**Field descriptions (Sheet 1 of 2)**

Field	Subfield or refinement	Entry	Explanation and action
ISGNO		0 to 255	ISDN Service Group number. Enter the ISDN service group (ISG) number. This number is equivalent to the ISG index from table ISGDEF.
TDCTAB		see subfields	TMS data channel table. This field consists of subfields TDC_CHNL, PRTCLPAR, DEVICE, VERSION, and CONFIG for information regarding each channel.
	TDC_CHNL	1 to 31	TDC channel. Enter the channel number of the TDC.
	PRTCLPAR	X25DCEH X25DCEL X25DCEM X25DTEL NILPROT	<p>Protocol parameters. Enter the set of protocol parameters.</p> <p>The following entries are valid:</p> <ul style="list-style-type: none"> <li>• X25DCEH is valid for high noise conditions.</li> <li>• X25DCEL is valid for low noise conditions.</li> <li>• X25DCEM is valid for medium noise conditions.</li> <li>• X25DTEL is valid for low noise conditions.</li> <li>• NILPROT is valid for an undefined TDC channel.</li> </ul> <p>There is no default.</p>
	DEVICE	DA, ORDB, TPC, CC	<p>Device. Enter the TMS P-side device.</p> <p>The default value is TPC.</p>

---

## TDCDEF (end)

---

### Field descriptions (Sheet 2 of 2)

Field	Subfield or refinement	Entry	Explanation and action
	VERSION	0 to 255	Version. Enter the version of the device configuration. The default value is 1.
	CONFIG	alphanumeric (1 to 32 characters)	Configuration. Enter the PVC layout configuration type defined in table PVCTYPE.

### Datavill example

The following example shows sample datavill for table TDCDEF.

### MAP display example for table TDCDEF

I	S	G	N	O	T	D	C	T	A			
32	(	11	X25DTEL	ORDB	202	CGI4)	(	12	X25DCEL	TPC	209	STD)\$

**TDCHLDY****Table name**

Multiunit Message Rate Holiday Table

**Functional description**

Table TDCHLDY defines billing on holiday days if other than normal billing rates apply.

The key into table TDCHLDY consists of the month (field MONTH) and day of the month (field DOMONTH).

The result is field BILLDAY, an index into table TDCSCHEM.

For related information, refer to table MRSANAME.

**Datafill sequence and implications**

There is no requirement to datafill other tables prior to table TDCHLDY.

**Table size**

0 to 365 tuples

**Datafill**

The following table lists datafill for table TDCHLDY.

**Field descriptions (Sheet 1 of 2)**

Field	Subfield or refinement	Entry	Explanation and action
HLDYINDX		see subfields	<i>Holiday index</i> This field consists of subfields MONTH and DOMONTH.
	MONTH	JAN, FEB, MAR, APR, MAY, JUN, JUL, AUG, SEP, OCT, NOV, or DEC	<i>Month of the holiday</i> Enter the month of the date on which other than normal rates apply.



**TDCHLDY** (end)

**Field descriptions (Sheet 2 of 2)**

Field	Subfield or refinement	Entry	Explanation and action
	DOMONTH	1 to 31	<i>Day of the month of the holiday</i> Enter the day of the month of the day on which other than normal rates apply.
BILLDAY		MONDAY TUESDAY WEDNESDAY THURSDAY FRIDAY SATURDAY SUNDAY HOLIDAY1 HOLIDAY2 or HOLIDAY3	<i>Billing day</i> Enter the index into table TDCSCHED.

**Datafill example**

The following example shows sample datafill for table TDCHLDY.

**MAP display example for table TDCHLDY**

HLDYINDX	BILLDAY
JAN 1	FRIDAY

**TDCSCHEDED****Table name**

Multiunit Message Rate Day and Time Treatment Table

**Functional description**

Table TDCSCHEDED defines the treatment index TREATMNT into table CHARGTAB.

The result in field TREATMNT is an index into table CHARGTAB, field TRTINDEX.

For related information, refer to table MRSANAME.

**Datafill sequence and implications**

There is no requirement to datafill other tables prior to table TDCSCHEDED.

**Table size**

0 to 10 tuples

**Datafill**

The following table lists datafill for table TDCSCHEDED.

**Field descriptions (Sheet 1 of 2)**

Field	Subfield or refinement	Entry	Explanation and action
BILLDAY		MONDAY TUESDAY WEDNESDAY THURSDAY FRIDAY SATURDAY SUNDAY HOLIDAY1 HOLIDAY2 or HOLIDAY3	<i>Billing day</i>  If the record is the first in the billing day list enter the key into table TDCSCHEDED. Otherwise, leave this field blank.
TDCVECTR		see subfields	<i>Time schedule vector</i>  This field consists of up to eight multiples of subfields TIME and TREATMNT. If less than eight multiples are required, end the list with a \$ (dollar sign).

**TDCSCHEd** (end)

**Field descriptions (Sheet 2 of 2)**

Field	Subfield or refinement	Entry	Explanation and action
	TIME	0 to 2400	<p><i>Time</i></p> <p>Enter the time, in hours and minutes, up to which the associated treatment in field TREATMNT applies.</p> <p>The starting time for the first TIME-TREATMNT pair is 0 (zero).</p>
	TREATMNT	CHGA CHGB CHGC or CHGD	<p><i>Treatment</i></p> <p>Enter the index into table CHARGTAB.</p>

**Datafill example**

The following example shows sample datafill for table TDCSCHEd.

**MAP display example for table TDCSCHEd**

BILLDAY	TDCVECTR
MONDAY	(2400 CHGA) \$

**TEAMACD**

---

**Table name**

TOPS Automatic Call Distribution Table

**Functional description**

This table is deleted in release TOPS12 since it is specific to ACD, which is manufacturer discontinued.

**Table history**

**TOPS12**

This table is deleted by feature 59006865 in functionality MD Code Removal and ReEngineering, OSB00001..

**BCS34**

Table TEAMACD was introduced.

---

## TELEPROF

---

### Table name

Telephony profile

### Functional description

Table TELEPROF defines the link between a telephony profile and a destination media gateway controller (MGC).

### Datafill sequence and meaning

You must enter datafill in table MGCINV before you can enter datafill in table TELEPROF.

### Table size

Table TELEPROF can support up to 8000 tuples

### Datafill

Table lists datafill for table TELEPROF.

### Field descriptions

Field	Subfield	Entry	Explanation and action
KEY		MGCNAME and TPROFILE name of up to 16 characters.	Key field. Enter the media gateway controller name (MGC) for the remote domain and the telephony profile name.

### Datafill example

Figure shows sample datafill for table TELEPROF.

### MAP display example for table TELEPROF

KEY	-----
CHARLOTTE	IBN_ISUP1

### Table History

#### SNH01

Table introduced to support CS 2000.

## TERMDEV

---

### Table name

Terminal Device Table

### Functional description

Table TERMDEV lists assignments for terminal devices.

The operating company completes the input for table TERMDEV. The switching unit input/output controller (IOC) assignments to the terminal devices appear on Northern Telecom drawing number D610.

See table MTD for the terminal devices with fixed assignments on the IOC.

Assign the trunk test positions (TTP) devices in order: TTP:00, TTP:01, TTP:02, and so on. Continue assignment until the assignment of all the TTP devices occurs. When the assignment completes, entry of the remaining printers and visual display units (VDU) in the table can occur.



#### **WARNING**

##### **Lockout condition can occur**

A lockout condition is present if all commands are privileged-classed (PRIVCLASS) out for all users and terminals. The only method in which to stop the lockout is to use the user identification (userid) ADMIN. An ADMIN userid does not appear. The system does not restrict an ADMIN. An ADMIN userid is available if knowledge of the ADMIN password is present. An ADMIN userid is available if the terminal is not in the automatic login (AUTOLOGIN) mode.

If the DMS switch has a heavy load, some terminals and one log device must continue to run. Call processing and maintenance load do not affect this condition. This base support occurs if guaranteed background tasks are present. Guaranteed tasks are limited in number. Guaranteed tasks run more than other tasks.

Guarantee of the following devices can occur:

- one network management (NWM) MAP (maintenance and administration position) or port
- one switching control center system (SCCS) MAP
- one local MAP

---

**TERMDEV** (continued)

---

- one service analysis position or interface
- one emergency technical assistance service (ETAS) reserved device
- one log device

A maximum of five devices can be guaranteed in table TERMDEV. Only one device can be guaranteed in table LOGDEV. The customer assigns these devices through datafill in tables TERMDEV and LOGDEV. A user logging into these devices has a guaranteed response.

Field GUAR is N by default. Change this setting if use of this feature is a requirement.

*Note:* To enter data table CUSTPROT can restrict access to table TERMDEV. Access limits must occur for operating companies in the United Kingdom. These limits occurs if table CUSTPROT receives data. The limits prevent the customer of third party system maintenance from reconfiguring terminal data. This type of change to terminal data affects automatic dial back and terminal command class limits.

If the switching unit contains feature AD0179 (ACD Real Time Display Enhancement), enter the datalink device in tables TERMDEV and SLLNKDEV. This entry assures connection in LNKUTIL. This entry generates the ACDRTD (ACD real time display) reports.

If the switching unit contains feature package NTX243AA (AMA teleprocessing system), enter the correct data in table TERMDEV. Entry of data for each of the two recording devices in the device processing peripheral (DPP) unit must occur. Enter data in table TERMDEV before you enter data into table DPP for the DPP links. Entry of data for terminals associated with data in different IOCs must occur to assure reliability.

Do not use the same class numbers when you enter data in tables TERMDEV, CUSTPROT, SUBPROT, or CMDS. The system does not distinguish between class numbers for commands and class numbers for system data table access privilege. Duplication of a class number can occur. This condition can cause the PERMIT command to provide intended access to a command and table access that was not intended. This event occurs because the PERMIT command assigns privilege classes for commands and for access to tables.

A change to table TERMDEV can affect the terminal data that table DPP uses. Delete the affected tuple from table DPP before the tuple from table TERMDEV.

## **TERMDEV** (continued)

---

Effective in BCS30, two C-side links allow outgoing messages Central control (CC) sends to the card received over C-side link 0. The BCS30 contains the 1X67FA device controller card for the Simplified Message Desk Interface (SMDI) feature. Outgoing messages the card sends to the CC route over C-side link 1.

Entry of data in table TERMDEV requires two tuples when two C-side links occur. This requirement occurs if table TERMDEV contains a console device that uses a 1X67FA terminal controller card. When the manual addition of the first tuple occurs, table control adds a second tuple automatically.

A two-tuple restriction on field TERMDSE occurs when data entry in a console device that uses the 1X67FA terminal controller occurs. In this even, a maximum field length of seven characters can occur. When the automatic addition of the second tuple occurs, the second, different tuple name takes the name of the first tuple. The capital letter I follows this name.

The maximum length of a tuple name in field TERMDSE is eight characters under the following condition. Entry of data in table TERMDEV, with a console device that does not use the 1X67FA card, allows this maximum.

See table MTD for additional information.

Effective in CSP03, field CKERDISC permits the display of the CkEr (Circuit Error) alarm on the MAP IOD banner. This display does not have to occur.

Table TERMDEV defines the SMDI card 1X67FA. In a disconnected state, this device can cause an alarm in the MAP EXT banner. The new CKERDISC field does not affect this alarm.

Effective CSP04, field MODEM allows for specification of direct dial-up modems. An entry of DUGEN specifies direct dial-up modems. These modems drop the call when the user logs out. If the entry of DUGEN occurs, the data transmit ready line in the 1X67BD card toggles. This action occurs when the user logs out and the call drops.

### **Datafill sequence and meaning**

Enter data in table IOC before you enter data into table TERMDEV.

### **Table size**

Memory allocation for a maximum of 128 terminal devices occurs automatically. These terminal devices include 59 SMDI type console devices and 64 non-SMDI devices. Reservation of the remaining five entries for other uses occurs.



**TERMDEV** (continued)

The maximum number of non-SMDI consoles available for data entry is 84 when an SMDI does not contain datafill.

**Datafill**

Datafill for table TERMDEV appears in the following table.

**Field descriptions (Sheet 1 of 5)**

Field	Subfield or refinement	Entry	Explanation and action
TERMDES		alphanumeric (a maximum of eight characters)	<p><i>Terminal designation.</i> Enter the name the operating company defines for each terminal device. Assignment of all TTPs must occur first, starting with the MAP. The MAP is TTP:00. The remaining TTPs follow in numerical order. After assignment of TTPs occurs, the assignment of other terminal devices can occur. Other terminal devices include as printers and VDUs</p> <p>Name dial-up facilities that ETAS and field service engineering (FSE) DIAL1, DIAL2, and so on, use.</p> <p><b>Note:</b> Enter a maximum eight characters unless the 1X67FA card is in use. The 1X67FA card requires seven characters.</p>
IOCNO		0 to 19	<p><i>Input/output controller number.</i> Enter the number of the IOC to which terminal device assignment occurs. See table MTD for details.</p>
CKTNO		0 to 35	<p><i>Input/output controller circuit number.</i> Enter the IOC circuit number to which terminal device assignment occurs. See table MTD for details.</p>

**TERMDEV** (continued)

## Field descriptions (Sheet 2 of 5)

Field	Subfield or refinement	Entry	Explanation and action
TERMTYPE		CYB, DEFAULTC, DPH, FPRT, HAZ, HP, KSR, LGR2, LSG, PRT, SMDI, SPRT, TEC, VT100, VT102, or VUC4	<p><i>Terminal type.</i> Enter one of the following terminal types:</p> <ul style="list-style-type: none"> <li>• CYB (Cybernex)</li> <li>• DEFAULTC (does not support MAP)</li> <li>• DPH (Displayphone)</li> <li>• FPRT (fast printer does not pad output line with nulls)</li> <li>• HAZ (Hazeltine)</li> <li>• HP (Hewlett-Packard)</li> <li>• KSR (keyboard send/receiver)</li> <li>• LGR2 (Cybernex)</li> <li>• LGR2 LSG (Lear Sigler)</li> <li>• PRT (printer pads output line with 15 nulls)</li> <li>• SMDI (simplified message desk interface)</li> <li>• SPRT (slow printer pads output line with 30 nulls)</li> <li>• TEC (TEC)</li> <li>• VT100</li> <li>• VT102</li> <li>• VUC4 (Vucom)</li> </ul> <p><b>Note:</b> Refer to the printer operating manual for number of nulls required.</p>

**TERMDEV** (continued)**Field descriptions (Sheet 3 of 5)**

<b>Field</b>	<b>Subfield or refinement</b>	<b>Entry</b>	<b>Explanation and action</b>
BAUDRT		B110, B134PT5, B150, B300, B600, B1200, B1800, B2000, B2400, B3600, B4800, B7200, B9600, or B19200	<i>Baud rate.</i> Enter the baud rate of the terminal device.
INTYP		CL or EIA	<i>Interface type.</i> If the terminal device has a data set or modem, enter EIA (electronic industries association interface). Enter CL (current loop) if this condition does not occur.
EQPEC		alphanumeric (a maximum of eight characters)	<i>Equipment product engineering code.</i> Enter the product engineering code (PEC) of the terminal controller card.
PRTY		EVEN, NONE, or ODD	<i>Parity.</i> Enter the parity of the terminal device.
GUAR		Y or N	<i>Guaranteed device.</i> Enter Y if the device is guaranteed. The device is guaranteed if the device continues to run and the call processing or maintenance load does not affect the device. Enter N if the device is not guaranteed.  The default value is N.

**TERMDEV** (continued)

## Field descriptions (Sheet 4 of 5)

Field	Subfield or refinement	Entry	Explanation and action
MODEM		CTS, DBANS, DUGEN, NONE, RIXON, or UDS	<p><i>Modem type.</i> The entry in this field describes the type of modem connected to the corresponding port. The entry determines the set of procedures to use for controlling the modem.</p> <p>If enhanced password control (automatic dial-back) is present, specify the type of modem. If the feature is not present, the entry is NONE.</p> <p>Enter CTS if the CTS212AH modem connects to the port.</p> <p>Enter DBANS if a modem connects to the port but does not have agency procedures. The modem does not have agency procedures if the modem is able to autoanswer. The modem is not able to autodial.</p> <p>Enter DUGEN for a dial-up generic modem type.</p> <p>Enter RIXON if the Rixon R212A modem connects to the port.</p> <p>Enter UDS if the Motorola UDS-224 connects to the port.</p>

**TERMDEV** (continued)**Field descriptions (Sheet 5 of 5)**

Field	Subfield or refinement	Entry	Explanation and action
COMCLASS		0 to 30, NONE, or ALL	<p><i>Command class.</i> Enter the command classes allowed for the terminal device. A blank space separates the command classes.</p> <p>Enter NONE if a limit on terminal commands occurs. Enter ALL if a restriction for terminal commands does not occur.</p> <p><b>Note:</b> If in table OFCOPT, set parameter ENHANCED_COMMAND_SCREENING to Y. Option NONE is not correct. Enter a minimum of one command in field COMCLASS.</p> <p>A user can log in at the terminal to perform commands allowed on the terminal. A user can log in at the terminal to perform commands allowed for the user login identification.</p>
CKERDISC		Y or N	<p><i>CkEr alarm on DISconnected device.</i> Enter Y if the device can cause a CkEr alarm when it is in a DISconnected state. Enter N if the device cannot cause a CkEr alarm.</p>

**Datafill example**

Sample datafill for table TERMDEV appears in the following example.

Standard datafill on a MAP device that is not guaranteed appears in the first tuple.

Datafill with a terminal ID for use in table DPP appears in the second tuple.

Datafill with a modem type of DUGEN appears in the third tuple.

**TERMDEV (end)**

**MAP example for table TERMDEV**

TERMD	ES	IOCNO	CKTNO	TERMTYPE	BAUDRT	INTYP	EQPEC	PRTY	GUAR
MAP		0	8	VT100	B2400	CL	1X67AA	NONE	
N	NONE								
				ALL					
			Y						
PRT0		0	8	KSR	B1200	EIA	1X67AA	NONE	
N	NONE								
				ALL					
			N						
DIAL1		0	10	VT100	B1200	EIA	1X67BD	NONE	
N	DUGEN								
				ALL					
			N						

**Table history**

**CSP06**

A reference to the datafill section was added in CSP06. The maximum number of non-SMDI consoles available for entry when no SMDI receives data appears in this reference.

**CSP04**

Entry DUGEN to field MODEM was added in CSP04.

A reference to the NT1X67BD EQPEC was added in CSP04.

Entry NONE is not a correct entry in field COMCLASS if office parameter ENHANCED\_COMMAND\_SCREENING contains a Y. A note stating this condition was added in CSP04.

**CSP03**

Field CKERDISC was added in CSP03.

**BCS36**

Entry SMDI to field TERMTYPE was added again in BCS36.

**TERMRC****Table name**

TOPS Point-to-point Rating Terminating Rate Centers Table

**Functional description**

Table TERMRC is used to divide the called area, where point-to-point rating applies, into terminating rate centers (TRC) by specifying for each called numbering plan area (NPA) Nxx combination of the TRC number it belongs to.

For related information, refer to table ORIGRC.

**Datafill sequence and implications**

Table HNPACONT must be datafilled before table TERMRC.

**Table size**

0 to 640 000 tuples

**Datafill**

The following table lists datafill for table TERMRC.

**Field descriptions**

Field	Subfield or refinement	Entry	Explanation and action
NPANXX		see subfields	Called NPA Nxx key for point-to-point rating. This field consists of subfields NPA and NXX.
	NPA	200 to 999	Called NPA. Enter the called numbering plan area (NPA) known to table HNPACONT
	NXX	200 to 999	Called Nxx. Enter the called Nxx.
TRC		1 to 255 (see note)	Point-to-point terminating rate center. Enter the number that the called NPA Nxx combination belongs to.  The value for this field cannot exceed the value of parameter TOPS_MAX_TERM_RATE_CENTER in table OFCENG.  <b>Note:</b> The DMS switch shows the range as 0-255, however, value 0 is a NIL value and not allowed by table control.

## **TERMRC** (end)

---

### **Datafill example**

Refer to the example in table ORIGRC.

### **Table history**

#### **NA005**

Changed range of field TRC from 0-255 to 1-255. Value 0 is a NIL value and not allow by table control per PRS UT56251.

#### **BCS36**

Range of field NPA was changed. New range is 200 to 999. Added table size of 0 to 640 000 tuples.



---

**TERMRCI**

---

**Table name**

TOPS Point-to-point Rating Terminating Rate Centers Inactive Table

**Functional description**

For related information, refer to tables TERMRC, ORIGRC, and CHARGEI.

**Datafill sequence and implications**

Table HNPACONT must be datafilled before table TERMRCI.

**Table size**

Refer to table TERMRC.

**Datafill**

Refer to table TERMRC.

**Datafill example**

Refer to table TERMRC.

**Table history****BCS36**

Table TERMRCI was introduced.

---

## TERM RTE

---

### Table name

Termination Routing

### Functional description

Table TERM RTE is used for direct termination routing to trunks exiting the Interexchange Carrier network.

### Datafill sequence and meaning

None

### Table size

Memory is allocated for 10000 tuples.

### Datafill

The table that follows lists datafill for the TERM RTE table.

### Field descriptions

Field	Subfield	Entry	Explanation and action
ROUTE	RTESEL	SQ	Standard route selector with queuing capabilities.
		NQ	Non-Standard route selector with queuing capabilities.
		QH	QH is considered a queue point is placed after the SQ and/or NQ selectors.
SQ	CONNTYP E	D	CONNECTION TYPE. Enter D for direct routing.
		CLLI	Valid CLLI datafilled in table TRKGRP COMMON LANGUAGE LOCATION IDENTIFIER. Enter a valid CLLI.
	OHQ	N or Y	OFFHOOK QUEUING. Enter Y if the trunk group is eligible for queuing.
NQ	CONNTYP E	D	CONNECTION TYPE. Enter D for direct routing.
		CLLI	Valid CLLI datafilled in table TRKGRP COMMON LANGUAGE LOCATION IDENTIFIER. Enter a valid CLLI.

**Field descriptions**

Field	Subfield	Entry	Explanation and action
	DELDIGS	0 TO 15	DELETE DIGITS. Enter the number of digits to delete before outpulsing.
	PRFXDIGS	Up to 11 digits (0 to 9) or N	PREFIX DIGITS. Enter the prefix digits. Enter N for none.
	CANCNOR C	N	CANCEL NORMAL CHARGE. The UCS software does not support this field, enter N.
	OHQ	N or Y	OFFHOOK QUEUING. Enter Y if the trunk group is eligible for queuing.
QH	QTIME	0 TO 255	QUEUE TIME. Enter the time in seconds a call is allowed in the queue.

**Datafill example**

The following example shows sample datafill for table TERMRTE.

11 (S D IP3EAN830C7DR01) (SQ D IP3EAN836C7DR07 Y) (QH 60)\$

354 (NQ D IP3EAN826C7DR05 3 919 N Y) (QH 90)\$

**Table history****CSP18/SN05**

Feature A19011775 adds table TERMRTE.

---

## TERMSCRN

---

### Table name

TOPS ACCS Terminating Code Screening Table

### Functional description

In TOPS (Traffic Operator Position System) offices with the TOPS Terminating Code Screening feature, table TERMSCRN is used to screen ACCS (Automatic Calling Card Service) calls to specific countries or NPA-NXX numbers from specific pay phones for purposes of fraud prevention. Terminating code screening applies only to ACCS calls to certain countries or regions (See tables OVSBILL, DOMBILL). If a region or country is terminating code screened and the calling number of the coin station matches an entry in this table, then the call is routed to a TOPS operator for alternative billing procedures.

For related information, refer to table HOTLIST.

### Datafill sequence and implications

There is no requirement to datafill other tables prior to table TERMSCRN.

### Datafill

The following table lists datafill for table TERMSCRN.

#### Field descriptions

Field	Subfield or refinement	Entry	Explanation and action
CLGNUM		numeric up to 18 digits	ACCS call originating coin station number. Enter the number of a coin station to be screened by a TOPS operator when originating an ACCS (Automatic Calling Card Service) call to a country or region where terminating code screening applies. Terminating code screening to a country or region applies when the country or region is listed in table OVSBILL with field CCSRN(Y) or in table DOMBILL with field CCSRN(Y).

### Datafill example

Using the example datafill for tables OVSBILL, DOMBILL, and TERMSCRN below:

- A coin station with a calling number of 613-555-1111 dials a friend in Mexico billing the call to a calling card. From table OVSBILL,

**TERMSCRN** (end)

terminating code screening applies to this call. From table TERMSCRN, the calling number matches the second entry (613555111) and the call is routed to a TOPS operator.

- A coin station with a calling number of 416-654-3210 dials Calgary billing the call to a calling card. From table DOMBILL, all calls to Alberta apply terminating code screening. From table TERMSCRN, the calling number matches the first entry (416654) and the call is routed to a TOPS operator.
- A coin station with a calling number of 416-654-3210 dials Turkey billing the call to a calling card. From table OVSBILL, terminating code screening does not apply, so the call is billed to the calling card.

**Datafill example for table OVSBILL**

COUNTRY	COLLECT	PERONLY	THIRDOK	CCSCRN	COLSCRN	THRDSCRN
MEXICO	ALW	N	N	Y	Y	Y
JAPAN	DEN	N	Y	Y	Y	Y
TURKEY	PER	N	N	N	Y	Y

**Datafill example for table DOMBILL**

REGION	COLLECT	PERONLY	THIRDNUM	CCARD	CCSCRN	COLSCRN	THRDSCRN
ALBERTA	DEN	Y	ALL	ALL	Y	Y	Y
BC	ALW	N	REG	NONE	Y	Y	Y
SASK	PER	N	NONE	REG	Y	N	Y

**MAP display example for table TERMSCRN**

CLGNUM
416654
613555111

---

## TEXTLOG

---

### Table name

Logical Display Text Table

### Functional description

Table TEXTLOG is used by Visual Screen List Editing (VSLE) and other display features. It contains the names of the physical phrases that make up a logical display phrase provided to guide the user during a VSLE session. The table is accessed using a three part key consisting of the name of the feature application with which the display string is associated, a numeric index to allow selection by the application of the appropriate display to be used, and the language used for the display.

### Datafill sequence and implications

Table TEXTPHRS must be datafilled before table TEXTLOG.

### Table size

0 to 256 tuples

### Datafill

The following table lists datafill for table TEXTLOG.

#### Field descriptions for table TEXTLOG (Sheet 1 of 3)

Field	Subfield or refinement	Entry	Explanation and action
LPHRSKEY		see subfields	<i>Logical phrase key</i> This field is the key of the table and consists of subfields APPLNAME, LANGUAGE, and DISPNUM.
	APPLNAME	CALLOG, VSLE	<i>Application name</i> Enter the name of the feature application for which this tuple is used as follows: <ul style="list-style-type: none"> <li>• CALLOG (Call Logging)</li> <li>• VSLE (Visual Screen List Editing)</li> </ul>
	LANGUAGE	NILANG LANG1 LANG2	<i>Language</i> Enter the language used for the display: LANG1, LANG2 or NILANG (no language).

**TEXTLOG** (continued)**Field descriptions for table TEXTLOG (Sheet 2 of 3)**

<b>Field</b>	<b>Subfield or refinement</b>	<b>Entry</b>	<b>Explanation and action</b>
	DISPNUM	0 to 127	<i>Display number</i> Enter the numeric index by which the feature application uniquely identifies the display data contained in the tuple.
DISPTYPE		C, S, or T	<i>Display type</i> Enter C for the cursor control display. This display type provides instructions and displays softkeys, used to wait for softkey or DTMF keypad input.  Enter S for the standard display. This display type is used to wait for softkey input from the user. Instructions are provided and softkeys displayed.  Enter T for the transient display. This display type provides an informational display to indicate results of user actions where no input is allowed.
LRCI(NA002-)		LEFT RIGHT CENTER INDENT	<i>Left Right Center Indent</i> This is the display justification indicator field. Enter the desired mode of justification.

**TEXTLOG** (continued)

**Field descriptions for table TEXTLOG (Sheet 3 of 3)**

Field	Subfield or refinement	Entry	Explanation and action
PHRSLIST		alphanumeric (2 to 8 characters)	<i>Phrase list</i> Enter the list of up to 16 physical phrase names as defined in table TEXTPHRS which together make up a single logical display phrase. If less than 16 phrase names are required, end the list with a \$ (dollar sign). The phrase names must be previously datafilled in table TEXTPHRS.
DEFNLIST		Up to 8 softkey definer lists	<i>Definer list</i> This field contains a vector of up to 8 softkey definer lists. The SOFTKEY subfield is the softkey definer number from the list of softkey definer numbers defined in field DEFNUM of table SOFTKEY. The value of the SOFTKEY subfield is 1 to 33. (The integer 1 is reserved internally to allow for an unused softkey to be left blank.) The value of the MODE subfield is N for normal or H for highlight. The softkey table (SKT) subfield indicates which softkey table is loaded in the CPE. The values are SRV for server or CPE for customer premises equipment. If less than 8 softkey definers are required, end the list with a \$ (dollar sign).
	SOFTKEY	1 to 33	
	MODE (NA002-)	N, H	
	SKT (NA002-)	SRV, CPE	

**Datafill example**

The following example shows sample datafill for table TEXTLOG.

**MAP display example for table TEXTLOG**

```

LPHRSKEY DISPTYPE LRCI
                PHRSLIST
                DEFNLIST
-----
CALLOG  LANG1  1          S LEFT
                                ( CLTITLE)$
                                ( 1 N SRV )$
    
```

**Table history**  
**NA004**

The tuple DSCWID was removed from table TEXTLOG.



**TEXTLOG** (end)

---

**NA002**

The field LRCI was added and subfields MODE and SKT were added to field DEFNLIST. Field DEFNLIST was also changed to allow eight softkey definer lists instead of seven.

---

## TEXTPHRS

---

### Table name

Text Phrases Table

### Functional description

Table TEXTPHRS is used by display features Visual Screen List Editing (VSLE) and Call Logging (CALLOG). It contains the instructional and prompting text strings which, when concatenated as specified in table TEXTLOG, make up individual logical display phrases. The table is accessed via a one-part key which is the name of the physical phrase. Each physical phrase can be up to 40 characters in length.

Table 1 lists the phrase names and their use in the default call logging (CALLOG) datafill. A dummy phrase is variable that is filled in when the phrase is formatted before it is sent to the customer premises equipment (CPE). For example, the dummy phrase CLCOUNT is replaced with a two digit integer (01 to 31) indicating the total number of entries in the subscriber's incoming call list (ICL).

#### CALLOG phrase name usage (Sheet 1 of 2)

Phrase Name	Usage
CLCOUNT	Generic phrase that is a two-digit field containing the current count of items in the ICL.
CLNEWCT	Generic phrase that is a two-digit field containing the count of NEW items in the ICL.
CLOLDCT	Generic phrase that is a two-digit field containing the count of OLD items in the ICL.
CLNAMEIT	Generic phrase that specifies an item with the NAME appearing in the primary column and information in the secondary column. The format of fields within this type cannot be changed.
CLDNIT	Generic phrase that specifies an item with the directory number (DN) appearing in the primary column and information in in the secondary column. The format of fields within this type cannot be changed.
CLPRIM	Generic phrase that is replaced by the NAME or DN, whichever is the primary as datafilled in table RESOFC, for the current item.
CLCURNUM	Generic phrase that is replaced with item number and new or old indicator for the currently selected item.
CLTITLE	Phrase used to specify the title of the call logging service.

**TEXTPHRS** (continued)**CALLOG phrase name usage (Sheet 2 of 2)**

Phrase Name	Usage
CLOLD	The word `Old' used in the header item of the virtual display.
CLNEW	The word `New' used in the header item of the virtual display.
CLDIAL	The phrase to be used in the primary column when an item is dialed.
CLREMOVE	The phrase to be used in the primary column when an item is removed.
CLERASED	Message to be displayed when the subscriber erases all calls in the ICL by pressing the ERASE softkey.
CLDNLD1	Part A of the download message.
CLDNLD2	Part B of the download message.
CLEEMPTY	Message displayed when the list is empty.
CLNODIAL	The phrase used when the subscriber attempts to dial an entry that contains a DN that cannot be dialed.
CLCLOSE	The phrase used when an error has occurred or the session has timed out, the message is put up, and the session terminated.

**Datafill sequence and implications**

There is no requirement to datafill other tables prior to table TEXTPHRS.

**Table size**

0 to 256 tuples

**TEXTPHRS** (continued)**Datafill**

The following table lists datafill for table TEXTPHRS.

**Field descriptions for table TEXTPHRS**

Field	Subfield or refinement	Entry	Explanation and action
PHRSNAME		alphanumeric (2 to 8 characters)	<i>Phrase name</i> Enter the character name of the physical phrase.
PHRASE		alphanumeric (up to 40 characters)	<i>Phrase</i> Enter the text string displayed to the user as instructional or prompting messages. The characters may be any alphanumeric character, except a blank. Interpretation of the characters is application specific, for example, the underscore (_) may be interpreted as a blank.  This field is a vector of up to 40 characters, however, display capabilities are only 20 characters at a time. The back quote (`) may be used to split a text string exceeding 20 characters in length so that a natural break between text may occur. Characters after the back quote (`) appear in the second 20 character field of the virtual display line.
HLMODE (NA002-)	POSITION MODE	see subfields 1 to 40 NORMAL REVERSE GREY BOLD	<i>Highlight mode</i> This field contains up to four highlight modes. Each mode consists of a position and a mode. Enter the character position of the change in highlight mode. The values range from 1 to 40. The characters specified in the POSITION subfield are highlighted according to the selected mode and continue until the end of the display or the next mode position is specified. The default mode is NORMAL if no HLMODE vectors are entered.

**Datafill example**

The following example shows sample datafill for table TEXTPHRS.

**TEXTPHRS** (end)**MAP display example for table TEXTPHRS**

PHRSNAME	PHRASE	HLMODE
CLCOUNT	GENERIC_CALLOG_ITEM_COUNT	\$
CLNEWCT	GENERIC_CALLOG_NEW_COUNT	\$
CLOLDCT	GENERIC_CALLOG_OLD_COUNT	\$
CLNAMEIT	GENERIC_CALLOG_NAME_ITEM	\$
CLDNIT	GENERIC_CALLOG_DN_ITEM	\$
CLPRIM	GENERIC_CALLOG_PRIMARY	\$
CLCURNUM	GENERIC_CALLOG_ITEM_NUMBER	\$
CLTITLE	Call_Logging_Service	\$
CLOLD	_Old	\$
CLNEW	_New_	\$
CLDIAL	Dialing...'	\$
CLREMOVE	Removed...'	\$
CLERASED	Erased_All_Calls	\$
CLDNL1	Processing_	\$
CLDNL2	_Calls	\$
CLEMPY	No_Calls...Hang_up	\$
CLNODIAL	Cannot_Return_Call	\$
CLCLOSE	Session_Complete	\$

**NA002**

Field HLMODE with subfields POSITION and MODE was added.

## TFANINT

---

### Table name

Traffic Separation Intersection Table

### Overview

The traffic separation intersection tables contain tables TFANINT and OCCTSINT.

The traffic separation measurement system (TSMS) uses table TFANINT to separate calls according to type of call. The TSMS separates calls at the intersection of specified source and destination traffic separation numbers.

The equal access traffic separation measurement system (EATSMS) uses table OCCTSINT to separate calls according to local access and transport area (LATA) and state attributes. The EATMSMS separates calls at the intersection of specified carrier and carrier trunk group traffic separation numbers.

The TSMS and EATSMS do not function together.

### Functional description

The use of table TFANINT in a DMS office can occur with TSMS. This condition occurs when the operating company must separate traffic according to the type of call.

The TSMS allows the operating company to separate direct dialed (DD), operator assisted (OA), and no prefix (NP) calls. The operating company can separate these calls for a maximum of 2048 traffic separation intersections.

The traffic separation numbers of the source and destination of the call index each entry in table TFANINT. The source can be a line or a trunk. The destination can be a line, trunk, announcement, or tone.

For each source traffic separation number and destination traffic separation number, table TFANINT has three registers. These registers correspond to the three types of calls, DD, OA, and NP. Each register contains a number that is an index to operational measurements (OM) group TFCANA.

For example, a caller can make a DD call from a line with a traffic separation number of 5. The caller makes this call to a trunk with a traffic separation number of 7. When this action occurs, the TSMS indexes the tuple in table TFANINT with field TFANIN = 5 and field TFANOUT = 7. The TSMS locates the DD register number that field DDREGNO specifies. The system uses this register number to increase the call count or to measure setup or connection use. Use the CI command OMSHOW or TFAN to view this data.

---

**TFANINT** (continued)

---

The assignment of source traffic separation numbers occurs in field TRAFSNO of table TRKGRP for incoming and two-way trunk groups. The assignment of source traffic separation numbers occurs in field TRAFSNO of table LINEATTR for line attributes.

The assignment of destination traffic separation numbers occurs in field TRAFSNO of the following tables:

- table TONES for tones
- table ANNS for announcements
- table LINEATTR for line attributes
- table TRKGRP for outgoing and two-way trunk groups

For a two-way trunk group or a line attribute, the source traffic separation number equals the destination traffic separation number.

**Datafill sequence and meaning**

Enter data in the following tables before you enter data in table TFANINT:

- ANNS
- TRKGRP
- TONES
- LINEATTR

**Table size**

0 to 2047 tuples

The system dynamically allocates memory. The system uses an average of 14 words of store for each tuple. You can assign the tuples in order. For example, tfanin/tfanout 1 0, 2 0, 3 0, 4 0. When you perform this action, the system uses an average of 8 words of store for each tuple.

**TFANINT** (continued)

**Datafill**

Datafill for table TFANINT appears in the following table.

**Field descriptions**

Field	Subfield or refinement	Entry	Description
INDX		see subfields	<i>Index.</i> This field contains subfields TFANIN and TFANOUT.
	TFANIN	0 to 127	<i>Source traffic separation number.</i> Enter the source traffic separation number assigned to the intersection.  The maximum number of source traffic separation numbers you can specify is 127. If you specify this number, storage restrictions limit the maximum of destination traffic separation numbers you can specify to 125.
	TFANOUT	0 to 127	<i>Destination traffic separation number.</i> Enter the destination traffic separation number assigned to the intersection.  The maximum number of destination traffic separation numbers you can be specify is 127. If you specify this number, storage restrictions limit the maximum number of source traffic separation numbers you can specify to 125.
DDREGNO		0 to 2047	<i>Direct dial register number.</i> Enter the register number assigned to the intersection for a peg count of DD calls. You can enter a number from 1 to 2047. If you do not require a peg count of DD calls, enter 0.  The number you enter cannot exceed the value of office parameter NO_TFAN_OM_REGISTERS in table OFCENG. The maximum value for NO_TFAN_OM_REGISTERS is 2047.



**TFANINT** (continued)**Field descriptions**

Field	Subfield or refinement	Entry	Description
OAREGNO		0 to 2047	<i>Operator assisted register number.</i> Enter the register number assigned to the intersection for a peg count of OA calls. You can enter a number from 1 to 2047. If you do not require a peg count of OA calls, enter 0.
NPREGNO		0 to 2047	<i>No prefix register number.</i> Enter the register number assigned to the intersection for a peg count of NP calls. You can enter a number from 1 to 2047. If you do not require a peg count of NP calls, enter 0.  The number you enter cannot exceed the value of office parameter NO_TFAN_OM_REGISTERS in table OFCENG. The maximum value for NO_TFAN_OM_REGISTERS is 2047.

**Datafill example**

Datafill for table TFANINT appears in the following description.

The first entry is for an incoming local trunk group. This group has source traffic separation number 7. The first entry is also for an outgoing local trunk group. This group has destination traffic separation number 9. The required peg counts are for NP calls. The NP register has the register number 1 assigned.

The second entry is for flat rate lines. These lines have source traffic separation number 8. The second entry is also for an outgoing-to-Traffic Operator Position System (TOPS) trunk group. This trunk group has destination traffic separation number 12. The DD calls (1+) have register number 4 assigned. The OA calls (0+) have register number 5 assigned. The operator calls (0-) have register number 6 assigned.

Sample datafill for table TFANINT appears in the following example.

## TFANINT (end)

---

### MAP example for table TFANINT

INDX	DDREGNO	OAREGNO	NPREGNO	
7	9	0	0	1
8	12	4	5	6

### Table history NCS17

Additional information added to table history, CSP03 section with CSR (Q00425985).

#### CSP03

The following changes were made in CSP03:

- Reference to table DATASIZE was removed. This table does not include TFANINT any longer. Information about store allocation was added to table DATASIZE.
- Reference to NORESTARTSWACT was removed. This reference was removed because activation is immediate.
- In instances where a register number is assigned, then reassigned to a new function, a MTCSWACTRELOAD is required to fully initialize the new register datafill information. The MTCSWACTRELOAD removes all software links to the register's previous assignment.
- The ranges of fields TFANIN and TFANOUT were changed to 0 to 127.
- Reference to office parameters TFAN\_IN\_MAX\_NUMBER and TFAN\_OUT\_MAX\_NUMBER was removed.

#### BCS36

A reference to the NORESTARTSWACT utility was added in BCS36.

**TFSSCRN****Table name**

Toll-Free Service Screening Table

**Functional description**

Table TFSSCRN lists the toll-free numbers subject to GR-2892 processing. When a number encounters the number service code (NSC) selector, a check is made to determine whether or not it is on the list. When the number is on the list, it bypasses TR-533 (E800) processing and proceeds as an AIN call.

**Datafill sequence and implications**

Table TRIGDIG is datafilled before table TFSSCRN.

When a corresponding AIN trigger is not present in table TRIGDIG the results are as follows:

- numbers in table TFSSCRN bypass E800
- a database query does not occur
- the call is routed to treatment

**Table size**

The minimum table size for table TFSSCRN is 0 tuples, and the maximum table size is 32k tuples. A restart is not required to increase table size.

**Datafill**

The following table lists datafill for table TFSSCRN.

**Field descriptions**

Field	Subfield or refinement	Entry	Explanation and action
TFSCODE		800,888,877, 866,855,844, 833,822	TFSCODE describes the toll-free code (SAC) in use.
FROMNXX		000 to 999	FROMNXX describes the lower bound of the range of the numbers in this SAC, that are processed by GR-2892.
TONXX		000 to 999	TONXX describes the upper bound of the range of the numbers belonging to GR-2892.  <b>Note:</b> The numbers belonging to GR-2892 must be greater than or equal to FROMNXX.

## TFSSCRN (end)

---

### Datavfill example

The following example shows sample datavfill for table TFSSCRN.

### MAP display example for table TFSSCRN

TFSCODE	FROMNXX	TONXX
800	622	733

### Table history

#### NA008

Table TFSSCRN is introduced by Toll-Free Service on Service Enablers (AR2219).

### Supplementary information

Not applicable

**TIESCDIG****Table name**

Trigger Item Escape Digits Table

**Functional description**

Table TIESCDIG administers the digit-based escape criteria for AIN trigger items in table TRIGITM.

**Datafill sequence and implications**

Datafill table TRIGITM after table TIESCDIG.

**Table size**

The system dynamically allocates the table size from 0 to 256 escape groups (0 to 32 000 tuples).

**Datafill**

The following table lists datafill for table TIESCDIG.

**Field descriptions**

Field	Subfield or refinement	Entry	Explanation and action
ESCGRP		Alphanumeric vector (1 to 8 characters)	Digit Based Escape Group Name. Datafill the escape group name.
ESCDIGS		Numeric vector (1 to 18 digits)	Escape Digits. Datafill a vector of 1 to 18 digits to represent the dialed digits.

**Datafill example**

The following example shows sample datafill for table TIESCDIG.

**MAP display example for table TIESCDIG**

ESCGRP	ESCDIGS
-----	-----
OBNAESC	514
OBNAESC	613622
OBNAESC	6135551212
OHDESC	819
OHDESC	514
OHDESC	613

**TIESCDIG** (end)

---

**Table history**

**NA010**

Feature AJ5123 AIN O\_BNA Trigger Screening (OTS) introduces table TIESCDIG in NA010.

---

**TIMEODAY**

---

**Table name**

Time of Day Table

**Functional description**

This table defines the time-of-day (TOD) result for a specified TOD system and day type (field DAYTYPE).

The Time of Day (TOD) feature is available in switching units with the following software packages:

- Integrated Business Network (IBN) Time of Day Routing (software package NTX433AA)
- IBN Time of Day Network Class of Service (NCOS) (software package NTX434AA)
- International Switching Units With Time of Day Routing (software package NTX488AA)
- DMS-300 switching units with Time of Day and Percentage Routing (software package NTX295AA)
- Network Advice of Charge (NAOC) Tariff and Time of Day Switchover

Feature BC1459 (Partitioned Table Editor) can be present in an IBN switch. If this feature is present, tables DATAOWNR and OWNTAB define the ownership of each tuple in this table. These tables define the tuples in the following way:

- The entries in table DATAOWNR that apply to table TIMEODAY have field TABNAME equal to the entry in field TODNAME. For these entries, the two fields equal the value of field TODNAME in this table.
- The entry in table OWNTAB that applies to this table is the entry with the entry in field TABNAME equal to TIMEODAY.

See table TODHEAD for additional information.

**Datafill sequence and meaning**

Enter data in the following tables before you enter data in table TIMEODAY:

- CARNAME
- RESNAME
- TARFINDX
- TODHEAD
- DAYTYPES

**TIMEODAY** (continued)

If the International DMS-100 Metering System is present in the switch, enter data in table LNETWORK. Enter data in this table before you enter data in table TIMEODAY.

If the IBN TOD NCOS Screening System is present in the switch, enter data in tables COSMAP and CUSTHEAD. Enter data in these tables before you enter data in table TIMEODAY.

If the IBN and DMS-300 TOD and Percentage Routing System is present in the switch, enter data in table IBNRTE. Enter data in this table before you enter data in table TIMEODAY.

**Table size**

0 to 16 640 tuples

**Datafill**

Datafill for table TIMEODAY appears in the following table.

**Field descriptions (Sheet 1 of 3)**

Field	Subfield or refinement	Entry	Description
TCOINDX		0 to 15	<p><i>Tariff of charge index</i></p> <p>This is value used for tariff indexing. This value overrides the index from table TODHEAD for the time period that starts with the actual TCO. The TCOINDX must already be in table TARIFINDX for this carrier. Enter the information for this field to activate the NAOC feature.</p>
TODNAME		alphanumeric (1 to 8 characters)	<p><i>Time of day name</i></p> <p>For the IBN or DMS-300 TOD Percentage Routing system, enter the name assigned to the TOD system. A minimum of one entry in table IBNRTE for an IBN switch is assigned this name. Tables OVR0-9 for a DMS-300 switch is assigned this name.</p> <p>This value contains the carrier/reseller name (name must be the same as the one entered in table TODHEAD and in either table CARNAME or RESNAME).</p>



**TIMEODAY** (continued)

## Field descriptions (Sheet 2 of 3)

Field	Subfield or refinement	Entry	Description
			For the IBN TOD NCOS screening system, enter the name assigned to the TOD system. The customer group in table CUSTHEAD with the option TODNCOS has this name assigned.
			For the International TOD DMS-100 Metering System, enter the name assigned to the TOD system.
DAYTYPE		alphanumeric (1 to 8 characters)	<i>Day type.</i> Enter the day type assigned to this TOD and Percentage Routing entry. Table DAYTYPES must already define the day type.
TIME		see subfields	<i>Time.</i> This field contains subfields HOUR and MINUTE.
	HOUR	0 to 23	<i>Hour.</i> Enter the starting hour for the TOD result.
	MINUTE	0 to 59	<i>Minute.</i> Enter the starting minute for the TOD result.
DATA		see subfield	<i>Data.</i> This field contains subfield TODTYPE.
	TODTYPE	MTR, RTE, or blank	<i>Time of day type</i> For the TOD DMS-100 Metering System, enter MTR. Enter data in refinements NETWORK and TNTNUM.
			For the IBN or DMS-300 TOD Percentage Routing System, enter RTE (route). Enter data in refinement TIME.
	LNETNAME	alphanumeric (1 to 8 characters)	<i>Logical metering network.</i> If the entry in subfield TODTYPE is MTR, enter data in this refinement. Enter the character logical metering network name assigned to this TOD DMS-100 metering system entry. Assignment of this name occurs in table LNETWORK.

**TIMEODAY** (continued)

## Field descriptions (Sheet 3 of 3)

Field	Subfield or refinement	Entry	Description
	TNTNUM	0 to 9	<i>Tariff number table number.</i> If the entry in subfield TODTYPE is MTR, enter data in this refinement. Enter the number of the tariff number table number that applies to the entry. Table MTARFNUM defines the TNTNUM, field TABLEKEY.
COSMAP		alphanumeric (1 to 16 characters)	<i>Class-of-service mapping.</i> If the entry in subfield TODTYPE is NCOS, enter data in this refinement. Enter the class-of-service name assigned to TOD NCOS screening. This name must already be assigned to the customer group in table CUSTHEAD with the option TODNCOS.
TIME		0 to 9 to F	A <i>Integrated Business Network time range.</i> If the entry in subfield TODTYPE is RTE, enter data in this refinement. Enter the time range that applies to the entry.

**Datafill example**

Five examples of datafill for table TIMEODAY follow.

**Example 1**

This example sets up a charge for the IBN or DMS-300 TOD System. Different routing occurs for weekdays, Saturdays, Sundays, statutory holidays and public service (PS) holidays.

The example indicates the rates that the operating company charges for the different times and day types. These rates are as follows:

- full rate on weekdays from 08:00 to 18:00
- 1/3 off in the evening
- 2/3 off 11:30 to 08:00

The TOD system does not provide the charge. The charge appears as an example of charging.

**TIMEODAY** (continued)

In this example, the final entry in each tuple indicates the price rate:

- 0 indicates two-thirds off or night-owl rate
- 1 indicates full rate
- 2 indicates one-third off or evening rate
- 3 indicates one-half off
- 4 indicates 60% off

The first tuple is two-thirds off. This tuple has field TIME set to 0. The second tuple is full rate. The third tuple is one-third off. The fourth and fifth tuples are two-thirds off. The sixth tuple is one-third off. This tuple is for Saturday from 8:00 to 18:00. The seventh and eighth tuples are two-thirds off. The ninth tuple is a statutory holiday and is half-off. The tenth tuple is a PS holiday and is 60% off.

**MAP example for table TIMEODAY**

TODNAME	DAYTYPE	TIME		DATA	
LONTODN	WEEKDAY	0	0	RTE	0
LONTODN	WEEKDAY	8	0	RTE	1
LONTODN	WEEKDAY	18	0	RTE	2
LONTODN	WEEKDAY	23	30	RTE	2
LONTODN	SATDAY	0	0	RTE	0
LONTODN	SATDAY	8	0	RTE	0
LONTODN	SATDAY	18	0	RTE	2
LONTODN	SUNDAY	0	0	RTE	0
LONTODN	STATHOL	0	0	RTE	3
LONTODN	PSHOL	0	0	RTE	4

**Example 2**

The following example of percentage routing allows the redirection of all or a percentage of overflow traffic. The system can redirect overflow traffic for specified routes through other off-peak switches. This action allows the system to maintain the level of service to the customer at all times of the day.

**TIMEODAY** (continued)

The simultaneous times in the different time zones for the United Kingdom (UK), United States (US), and Hong Kong (HKG) appear in the following table.

**Example of time zones for table TIMEODAY**

UK	USA	HKG
08:00	03:00	20:00
12:00	07:00	00:00
16:00	11:00	04:00
19:00	14:00	07:00
00:00	19:00	12:00

The UK and HKG operating companies can agree to route the overflow USA/CANADA traffic from 12:00 to 19:00 through HKG. The UK operating company can route this traffic when the HKG time zone is OFF-PEAK and the equipment is under-used. This feature provides routing flexibility for maximum equipment use of calls through DMS-300.

The routing of a percentage of the USA/CANADA traffic on weekdays through HKG appears in the following example. This routing occurs during the HKG off-peak time (00:00 - 07:00).

**MAP example for table TIMEODAY**

TODNAME	DAYTYPE	TIME	DATA
US300	WEEKDAY	12 0	RTE 0
US300	WEEKDAY	16 0	RTE 0
US300	WEEKDAY	19 0	RTE 1

**Example 3**

Datafill for an IBN TOD NCOS screening entry for a TOD system with the name LONTODN appears in the following example.

**TIMEODAY** (continued)**MAP example for table TIMEODAY**

TODNAME	DAYTYPE	TIME	DATA
LONTODN	WEEKDAY	0 0	NCOS NCOSTODMAP

**Example 4**

Datafill for an international TOD DMS-100 metering system for a TOD system with the name CUST03 appears in the following example.

**MAP example for table TIMEODAY**

TODNAME	DAYTYPE	TIME	DATA
LONTODN	WEEKDAY	0 0	MTR NATIONAL 2

**Example 5**

Datafill that the system can use to route service calls appears in the following example. The way that the system routes these calls differs from normal business hours. An example of a service call is repair service.

The system uses this data to route calls on Monday to Friday from 08:30 to 17:30 to the repair service desk. The system routes calls during the following times to a destination other than the repair service desk:

- from 17:30 to 08:29 on Monday to Friday
- all day Saturday and Sunday

**MAP example for table TIMEODAY**

TODNAME	DAYTYPE	TIME	DATA
REPAIR	WEEKDAY	0 0	RTE 0
REPAIR	WEEKDAY	8 30	RTE 1
REPAIR	WEEKDAY	17 30	RTE 0
REPAIR	WEEKDAY	0 0	RTE 0

## **TIMEODAY** (end)

---

### **Table history**

#### **MMP15**

The table TIMEODAY specifies changeovers that occur at given times of the day. With feature 59023132, the number of tariffs that can be specified is increased from 8 to 10.

#### **MMP12**

The TCOINDX field was new to table TIMEODAY. This field activates the NAOC feature.

#### **EUR006**

The following values were added to field DATA in EUR006:

- LNETNAME
- TNTNUM

The range of values in field TODTYPE was changed to include MTR or RTE in EUR006.

---

**TIMESPEC**

---

**Table name**

Timed Semi-permanent Connections Table

**Functional description**

Table TIMESPEC defines the times that two endpoints are active in a switch. It allows the automatic establishment and removal of semi-permanent connections.

Timed semi-permanent connections are set up by adding an entry into table TIMESPEC. Table TIMESPEC contains the two endpoints of the connection, the first and last date of the connection and the days of the week and times that the connection is made.

Each entry in table TIMESPEC automatically enters tuples in table SPECCONN which specifies regular semi-permanent or nailed-up connections when the time criteria is met.

Table TIMESPEC is intended for the DMS-300, however the use of non-trunk related endpoints used as timed semi-permanent connections is not precluded.

On the DMS-300, only digital trunk controllers (DTC) and pulse code modulation (PCM) 30 DTCs (PDTC) peripheral module (PM) types are supported.

Use the following steps to set up a timed semi-permanent connection:

1. Add the two endpoints to table SPECCONN (verify the connection using normal nailed up connection tests such as loop-back or bit error rate (BERT) testing).
2. Once the connection is verified, remove the entry from table SPECCONN.
3. Datafill table TIMESPEC using the same endpoints and include the timed information. When the connection is active, the tuple appears as read-only in table SPECCONN.

*Note:* Endpoints that are manually added to table SPECCONN must not have any entries in table TIMESPEC.

**Datafill sequence and implications**

Table SPECCONN must be datafilled before table TIMESPEC.

**Table size**

0 to 4095 tuples

**TIMESPEC** (continued)

---

**Datafill**

The following table lists datafill for table TIMESPEC.

**Field descriptions (Sheet 1 of 2)**

<b>Field</b>	<b>Subfield or refinement</b>	<b>Entry</b>	<b>Explanation and action</b>
TIMEIDX		0 to 4095	<i>Time index</i> Enter the time index.
ENDPT1		see subfield	<i>End point1</i> This field is the identifier of the first endpoint of the semi-permanent connection. This field consists of subfield SCSEL.  <b>Note:</b> To change an endpoint in a tuple in table TIMESPEC, the tuple must be deleted and then readded. The table editor CHANGE command cannot be used.



**TIMESPEC** (continued)**Field descriptions (Sheet 2 of 2)**

<b>Field</b>	<b>Subfield or refinement</b>	<b>Entry</b>	<b>Explanation and action</b>
	SCSEL	D30, DCHCHNL, DS0T, DS1, ISLC, RCUL, or ST	<p><i>End point selector</i></p> <p>Enter the type of selector for the endpoint.</p> <p>When datafill is complete for the first endpoint selector, go to field ENDPT2, section Endpoint.</p> <p>When datafill is complete for both endpoints, go to field ABSIG, section Both endpoints.</p> <p>Enter D30 for PCM30 format and datafill refinement PMTYPE, section SCSEL = D30..</p> <p>Enter DCHCHNL (D-channel handler channel) for endpoints that traverse a subscriber carrier module-100 urban (SMU) equipped with the ISDN signaling preprocessor (ISP)16 option and datafill refinements ISGNO and CHNL, section SCSEL = DCHCHNL.</p> <p>Enter DS0T and datafill refinements XPMTYPE, PMNO, PORT, CHNL, and TCINFO, section SCSEL = DS0T. See note under RCUL.</p> <p>Enter DS1 for endpoints that traverse a subscriber carrier module-100 urban (SMU) equipped with the ISDN signaling preprocessor (ISP)16 option and datafill refinement PMTYPE, section SCSEL = D30.</p> <p>Enter ISLC (ISDN U-line card) and datafill refinement LEN, section SCSEL = ISLC.</p> <p>Enter RCUL (remote carrier urban) and datafill refinements LEN and TCINFO, section SCSEL = ISLC.</p> <p><b>Note:</b> Endpoints DS0T and RCUL cannot be connected to DS1, ISLC, or DCHCHNL endpoints.</p> <p>Enter ST (signaling terminal) and datafill refinement STNO, section SCSEL = ST.</p> <p>Any entry outside the range indicated for this field is invalid.</p>

**TIMESPEC** (continued)**SCSEL = D30**

If the entry in field SCSEL is D30, datafill refinement PMTYPE as described below.

**Field description for conditional datafill (Sheet 1 of 2)**

Field	Subfield or refinement	Entry	Explanation and action
	PMTYPE	PDTCPLGCR C02orSMA	<p><i>Peripheral module type</i> Enter the peripheral module (PM) type. Refinements are shown following this field in alphabetical order.</p> <p>Enter PDTC (pulse code modulation [PCM]30 digital trunk controller) and datafill refinements DEQNO, DEQCKTNO, and DEQCKTTS.</p> <p>Enter PLGC (PCM30 line group controller) and datafill refinements DEQNO, DEQCKTNO, and DEQCKTTS.</p> <p>Enter RCO2 (offshore remote cluster controller 2) and datafill refinements RCO2NO, RCO2CKTNO, and RCO2CKTTS.</p> <p>Enter SMA (subscriber carrier module-100S access) and datafill refinements SMANO, SMACKTNO, and SMACKTTS.</p> <p>Any entry outside the range indicated for this field is invalid.</p>
	DEQNO	0 to 511	<p><i>Equipment module number</i> If the entry in refinement PMTYPE is PDTC or PLGC, datafill this refinement. Enter the external number of the PM.</p>
	DEQCKTNO	0 to 19	<p><i>Equipment module circuit number</i> If the entry in refinement PMTYPE is PDTC or PLGC, datafill this refinement. Enter the peripheral (P)-side port number on the equipment.</p>
	DEQCKTTS	1 to 31	<p><i>Equipment module time slot</i> If the entry in refinement PMTYPE is PDTC or PLGC, datafill this refinement. Enter the time slot (channel) on the D30.</p>

**TIMESPEC** (continued)**Field description for conditional datafill (Sheet 2 of 2)**

<b>Field</b>	<b>Subfield or refinement</b>	<b>Entry</b>	<b>Explanation and action</b>
	RC02NO	0 to 511	<i>RC0 2 number</i> If the entry in refinement PMTYPE is RCO2, datafill this refinement. Enter the external number of the RC02.
	RC02CKTNO	0 to 47	<i>RC02 circuit number</i> If the entry in refinement PMTYPE is RCO2, datafill this refinement. Enter the P-side port number on the RC02.
	RC02CKTTS	1 to 31	<i>RC02 time slot</i> If the entry in refinement PMTYPE is RCO2, datafill this refinement. Enter the time slot (channel) on the D30.
	SMANO	0 to 511	<i>SMA number</i> If the entry in refinement PMTYPE is SMA, datafill this refinement. Enter the external number of the SMA.
	SMACKTNO	0 to 19	<i>SMA circuit number</i> If the entry in refinement PMTYPE is SMA, datafill this refinement. Enter the P-side port number on the SMA.
	SMACKTTS	1 to 24	<i>SMA time slot</i> If the entry in refinement PMTYPE is SMA, datafill this refinement. Enter the time slot (channel) on the D30.

**TIMESPEC** (continued)**SCSEL = DCHCHNL**

If the entry in field SCSEL is DCHCHNL, datafill refinements ISGNO and CHNL as described below.

**Field descriptions for conditional datafill**

Field	Subfield or refinement	Entry	Explanation and action
	ISGNO	0 to 255	<i>ISDN signaling group (D-channel handler number)</i> Enter the D-channel handler (DCH) identifier.
	CHNL	0 to 31	<i>Channel number</i> Enter the channel on the DCH.

**SCSEL = DS0T**

If the entry in subfield SCSEL is DS0T, datafill refinements XPMTYPE, PMNO, PORT, CHNL, and subfield TCINFO as described below.

**Field descriptions for conditional datafill (Sheet 1 of 2)**

Field	Subfield or refinement	Entry	Explanation and action
	XPMTYPE	SMU	<i>Extended multiprocessor system (XMS) peripheral module (XPM) type</i> Enter SMU for the subscriber carrier module-100S urban.
	PMNO	0 to 255	<i>Peripheral module number</i> Enter the external number of the SMU.
	PORT	0 to 19	<i>Port</i> Enter the P-side port number of the SMU.
	CHNL	1 to 24	<i>Channel</i> Enter the time slot (channel) on the DS1.
	TCINFO	see subfield	<i>Trunk conditioning information</i> This field consists of subfield CGAMODE.

**TIMESPEC** (continued)**Field descriptions for conditional datafill (Sheet 2 of 2)**

Field	Subfield or refinement	Entry	Explanation and action
	CGAMODE	DT, FT, OP, VN, or VT	<p>CARRIER GROUP ALARM MODE Enter the type of trunk conditioning applied on each channel.</p> <ul style="list-style-type: none"> <li>• DT (dataport transparent) A Multiplexer out-of-synchronization (MUX-OOS) PCM pattern (00011010) is transmitted. No A- or B-bits are transmitted.</li> <li>• FT (full transparent) No trunk conditioning is applied. The incoming PCM pattern is transmitted. No A- or B-bits are used.</li> <li>• OP (optional) Operating company personnel supply a PCM pattern in hexadecimal. No A- or B-bits are used. Datafill refinement TCPCM.</li> <li>• VN (voice nontransparent) Idle PCM (01111111) is transmitted. Datafill refinement TCSIG.</li> <li>• VT (voice transparent) Idle PCM is transmitted. No A- or B-bits are transmitted.</li> </ul>
	TCPCM	00 to FF	<p><i>Trunk conditioning PCM pattern</i> If the entry in subfield CGAMODE is OP, datafill this refinement. Enter a two-digit hexadecimal value used in trunk conditioning.</p>
	TCSIG	0000 to 1111	<p><i>Trunk conditioning signaling bits</i> If the entry in subfield CGAMODE is VN, datafill this refinement. Enter four bits. The first two bits, A1 and B1, are the A- and B-bits transmitted for the first 2.5 seconds. The second two bits, A2 and B2, are the A- and B-bits transmitted for the duration of the failure.</p>

**TIMESPEC** (continued)

**SCSEL = DS1**

If the entry in field SCSEL is DS1, datafill refinement PMTYPE as described below.

**Field descriptions for conditional datafill (Sheet 1 of 6)**

Field	Subfield or refinement	Entry	Explanation and action
	PMTYPE	DTC, IAC, LGC, LTC, PDTC, RCC2, RCCI, SMA, SMU, SRCC, or TMS	<p><i>Peripheral module type</i></p> <p>Enter the type of peripheral module and datafill its refinements. Refinements are shown following this field in alphabetical order.</p> <p>Enter DTC (digital trunk controller) and datafill refinements DTCNO, DTCKTNO, and DTCKTTS. See note under PDTC.</p> <p>Enter IAC (ISDN access controller) and datafill refinements IACNO, IACKTNO, and IACKTTS.</p> <p>Enter LGC (line group controller) and datafill refinements LGCNO, LGCKTNO, and LGCKTTS.</p> <p>Enter LTC (line trunk controller) and datafill refinements LTCNO, LTCKTNO, and LTCKTTS.</p> <p>Enter PDTC (pulse code modulation [PCM]30 DTC) and datafill refinements DEQNO, DEQCKTNO, and DEQCKTTS.</p> <p><b>Note:</b> On the DMS-300, only DTCs and PDTCs are supported.</p> <p>Enter RCC2 (remote cluster controller 2) and datafill refinements RCC2NO, RCC2CKTNO, and RCC2CKTTS.</p>

**TIMESPEC** (continued)**Field descriptions for conditional datafill (Sheet 2 of 6)**

Field	Subfield or refinement	Entry	Explanation and action
			<p>Enter RCCI (ISDN remote cluster controller) and datafill refinements RCCINO, RCCICKTNO, and RCCICKTTS.</p> <p>Enter SMA (subscriber carrier module-100S access) and datafill refinements SMANO, SMACKTNO, and SMACKTTS.</p> <p>Enter SMU (subscriber carrier module-100S urban) and datafill refinements SMUNO, SMUCKTNO, and SMUCKTTS.</p> <p>Enter SRCC (Synchronous Optical Network [SONET] remote cluster controller) and datafill refinements SRCCNO, SRCCKTNO, and SRCCKTTS.</p> <p>Enter TMS (Traffic Operator Position System [TOPS] message switch) and datafill refinements TMSNO, TMSCKTNO, and TMSCKTTS.</p> <p>Any entry outside the range indicated for this field is invalid.</p>
	DEQNO	0 to 511	<p><i>PDTC number</i></p> <p>If the entry in refinement PMTYPE is PDTC, datafill this refinement. Enter the external number of the PDTC.</p>
	DEQCKTNO	0 to 19	<p><i>PTDC circuit number</i></p> <p>If the entry in refinement PMTYPE is PDTC, datafill this refinement. Enter the P-side port number on the PDTC.</p>
	DEQCKTTS	1 to 31	<p><i>PDTC time slot</i></p> <p>If the entry in refinement PMTYPE is PDTC, datafill this refinement. Enter the time slot (channel) on the DS1.</p>
	DTCNO	0 to 511	<p><i>DTC number</i></p> <p>If the entry in refinement PMTYPE is DTC, datafill this refinement. Enter the external number of the DTC.</p>

**TIMESPEC** (continued)**Field descriptions for conditional datafill (Sheet 3 of 6)**

<b>Field</b>	<b>Subfield or refinement</b>	<b>Entry</b>	<b>Explanation and action</b>
	DTCCKTNO	0 to 19	<i>DTC circuit number</i> If the entry in refinement PMTYPE is DTC, datafill this refinement. Enter the P-side port number on the DTC.
	DTCKTTTS	1 to 24	<i>Time slot</i> If the entry in refinement PMTYPE is DTC, datafill this refinement. Enter the time slot (channel) on the DS1.
	IACNO	0 to 127	<i>IAC number</i> If the entry in refinement PMTYPE is IAC, datafill this refinement. Enter the external number of the IAC.
	IACCKTNO	0 to 19	<i>IAC circuit number</i> If the entry in refinement PMTYPE is IAC, datafill this refinement. Enter the P-side port number on the IAC.
	IACCKTTS	1 to 24	<i>IAC time slot</i> If the entry in refinement PMTYPE is IAC, datafill this refinement. Enter the time slot (channel) on the DS1.
	LGCNO	0 to 511	<i>LGC number</i> If the entry in refinement PMTYPE is LGC, datafill this refinement. Enter the external number of the LGC.
	LGCKTNO	0 to 19	<i>LGC circuit number</i> If the entry in refinement PMTYPE is LGC, datafill this refinement. Enter the P-side port number on the LGC.
	LGCKTTS	1 to 24	<i>Time slot</i> If the entry in refinement PMTYPE is LGC, datafill this refinement. Enter the time slot (channel) on the DS1.
	LTCNO	0 to 511	<i>LTC module number</i> If the entry in refinement PMTYPE is LTC, datafill this refinement. Enter the external number of the LTC.



**TIMESPEC** (continued)**Field descriptions for conditional datafill (Sheet 4 of 6)**

<b>Field</b>	<b>Subfield or refinement</b>	<b>Entry</b>	<b>Explanation and action</b>
	LTCKTNO	0 to 19	<i>LTC circuit number</i> If the entry in refinement PMTYPE is LTC, datafill this refinement. Enter the P-side port number on the LTC.
	LTCKTTS	1 to 24	<i>LTC time slot</i> If the entry in refinement PMTYPE is LTC, datafill this refinement. Enter the time slot (channel) on the DS1.
	RCC2NO	0 to 511	<i>RCC2 number</i> If the entry in refinement PMTYPE is RCC2, datafill this refinement. Enter the external number of the RCC2.
	RCC2CKTNO	0 to 47	<i>RCC2 circuit number</i> If the entry in refinement PMTYPE is RCC2, datafill this refinement. Enter the P-side port number on the RCC2.
	RCC2CKTTS	1 to 24	<i>RCC2 time slot</i> If the entry in refinement PMTYPE is RCC2, datafill this refinement. Enter the time slot (channel) on the DS1.
	RCCINO	0 to 511	<i>RCCI number</i> If the entry in refinement PMTYPE is RCCI, datafill this refinement. Enter the external number of the RCCI.
	RCCICKTNO	0 to 19	<i>RCCI circuit number</i> If the entry in refinement PMTYPE is RCCI, datafill this refinement. Enter the P-side port number on the RCCI.
	RCCICKTTS	1 to 24	<i>RCCI time slot</i> If the entry in refinement PMTYPE is RCCI, datafill this refinement. Enter the time slot (channel) on the DS1.
	SMANO	0 to 511	<i>SMA number</i> If the entry in refinement PMTYPE is SMA, datafill this refinement. Enter the external number of the SMA.

**TIMESPEC** (continued)**Field descriptions for conditional datafill (Sheet 5 of 6)**

<b>Field</b>	<b>Subfield or refinement</b>	<b>Entry</b>	<b>Explanation and action</b>
	SMACKTNO	0 to 19	<i>SMA circuit number</i> If the entry in refinement PMTYPE is SMA, datafill this refinement. Enter the P-side port number on the SMA.
	SMACKTTS	1 to 24	<i>SMA time slot</i> If the entry in refinement PMTYPE is SMA, datafill this refinement. Enter the time slot (channel) on the DS1.
	SMUNO	0 to 511	<i>SMU number</i> If the entry in refinement PMTYPE is SMU, datafill this refinement. Enter the external number of the SMU.
	SMUCTNO	0 to 19	<i>SMU circuit number</i> If the entry in refinement PMTYPE is SMU, datafill this refinement. Enter the P-side port number on the SMU.
	SMUCTTS	1 to 24	<i>SMU time slot</i> If the entry in refinement PMTYPE is SMU, datafill this refinement. Enter the time slot (channel) on the DS1.
	SRCCNO	0 to 511	<i>SRCC number</i> If the entry in refinement PMTYPE is SRCC, datafill this refinement. Enter the external number of the SRCC.
	SRCCCKTNO	0 to 47	<i>SRCC circuit number</i> If the entry in refinement PMTYPE is SRCC, datafill this refinement. Enter the P-side port number on the SRCC.
	SRCCCKTTS	1 to 24	<i>SRCC time slot</i> If the entry in refinement PMTYPE is SRCC, datafill this refinement. Enter the time slot (channel) on the DS1.
	TMSNO	0 to 255	<i>TMS number</i> If the entry in refinement PMTYPE is TMS, datafill this refinement. Enter the external number of the TMS.

**TIMESPEC** (continued)**Field descriptions for conditional datafill (Sheet 6 of 6)**

Field	Subfield or refinement	Entry	Explanation and action
	TMSCKTNO	0 to 19	<i>TMS circuit number</i> If the entry in refinement PMTYPE is TMS, datafill this refinement. Enter the P-side port number on the TMS.
	TMSCKTTS	1 to 31	<i>TMS time slot</i> If the entry in refinement PMTYPE is TMS, datafill this refinement. Enter the time slot (channel) on the DS1.

**SCSEL = ISLC**

If the entry in field SCSEL is ISLC, datafill refinements LEN and CHNL as described below.

**Field descriptions for conditional datafill**

Field	Subfield or refinement	Entry	Explanation and action
	LEN	see subfields	<i>Line equipment number</i> This field defines the physical location of the equipment that is connected to a specific telephone line.  Because field LEN is common to more than 60 tables, it is documented in a single section to avoid unnecessary duplication. Refer to section "Common entry field LEN" for a complete description of field LEN and associated subfields.  Field LEN consists of subfields SITE, FRAME, UNIT, DRAWER or LSG, SHELF, SLOT, and CIRCUIT.
	CHNL	B1, B2, or D	<i>Channel</i> Enter the channel on the ISLC.

**TIMESPEC** (continued)**SCSEL = RCUL**

If the entry in field SCSEL is RCUL, datafill refinements LEN, TCINFO, ATTN, and FXGCBA as described below.

**Field descriptions for conditional datafill (Sheet 1 of 3)**

<b>Field</b>	<b>Subfield or refinement</b>	<b>Entry</b>	<b>Explanation and action</b>
	LEN	see subfields	<p><i>Line equipment number</i> This field defines the physical location of the equipment that is connected to a specific telephone line.</p> <p>Because field LEN is common to more than 60 tables, it is documented in a single section to avoid unnecessary duplication. Refer to section "Common entry field LEN" for a complete description of field LEN and associated subfields.</p> <p>Field LEN consists of subfields SITE, FRAME, UNIT, DRAWER or LSG, SHELF, SLOT, and CIRCUIT.</p>
	TCINFO	see subfield	<p><i>Trunk conditioning information</i> This field consists of subfield CGAMODE.</p>

**TIMESPEC** (continued)**Field descriptions for conditional datafill (Sheet 2 of 3)**

Field	Subfield or refinement	Entry	Explanation and action
	CGAMODE	DT, FT, OP, VN, or VT	<p><i>Carrier group alarm mode</i> Enter the type of trunk conditioning applied on each channel.</p> <ul style="list-style-type: none"> <li>• DT (dataport transparent) A Multiplexer out-of-synchronization (MUX-OOS) PCM pattern (00011010) is transmitted. No A- or B-bits are transmitted.</li> <li>• FT (full transparent) No trunk conditioning is applied. The incoming PCM pattern is transmitted. No A- or B-bits are used.</li> <li>• OP (optional) Operating company personnel supply a PCM pattern in hexadecimal. No A- or B-bits are used. Datafill refinement TCPCM.</li> <li>• VN (voice nontransparent) Idle PCM (01111111) is transmitted. Datafill refinement TCSIG.</li> <li>• VT (voice transparent) Idle PCM is transmitted. No A- or B-bits are transmitted.</li> </ul>
	TCPCM	00 to FF	<p><i>Trunk conditioning pcm pattern</i> If the entry in subfield CGAMODE is OP, datafill this refinement. Enter a two-digit hexadecimal value used in trunk conditioning.</p>
	TCSIG	0000 to 1111	<p><i>Trunk conditioning signaling bits</i> If the entry in subfield CGAMODE is VN, datafill this refinement. Enter four bits. The first two bits, A1 and B1 are the A- and B-bits transmitted for the first 2.5 s. The second two bits, A2 and B2, are the A- and B-bits transmitted for the duration of the failure.</p>

**TIMESPEC** (continued)**Field descriptions for conditional datafill (Sheet 3 of 3)**

<b>Field</b>	<b>Subfield or refinement</b>	<b>Entry</b>	<b>Explanation and action</b>
	ATTEN	0 to 7	<i>Attenuation</i> Enter the amount of receive loss in dB inserted by the Foreign Exchange with Battery Reversal (FXB) card. Any value for special services module (SSM) channel units can be entered. The system subsequently sets the field to 0 (zero) automatically.
	FXBCGA	ON or OFF	<i>Foreign exchange with battery reversal carrier group alarm</i> Enter ON if the RCU to subscriber side supervisory signaling is onhook. Enter OFF if the RCU to subscriber-side supervisory signaling is offhook. Any value for SSM channel units can be entered. The system subsequently sets the field to ON automatically.

**SCSEL = ST**

If the entry in field SCSEL is ST, datafill refinement STNO as described below.

**Field descriptions for conditional datafill**

<b>Field</b>	<b>Subfield or refinement</b>	<b>Entry</b>	<b>Explanation and action</b>
	STNO	0 to 1023	<i>Signaling terminal number</i> Enter the signaling terminal number from table STINV.

**TIMESPEC** (continued)**Endpoint 2**

To complete datafill for the second endpoint, datafill field ENDPT2 and its refinements as described below.

**Field descriptions for conditional datafill**

Field	Subfield or refinement	Entry	Explanation and action
	ENDPT2	see subfield	<p><i>End point2</i></p> <p>This field is the identifier of the second endpoint of the connection. This field consists of subfield SCSEL and refinements.</p> <p>Go to subfield SCSEL and continue datafill.</p>

**Both endpoints**

For both ENDPOINT1 and ENDPOINT2, datafill the following fields.

**Field descriptions for conditional datafill (Sheet 1 of 3)**

Field	Subfield or refinement	Entry	Explanation and action
	ABSIG	Y or N	<p><i>A and B signaling bit preservation</i></p> <p>Enter Y (yes) to preserve the A and B signaling bits.</p>
	STARTDAT	see subfields	<p><i>Start date</i></p> <p>This field consists of subfields STARTMTH, DAY and YEAR.</p>
	STARTMTH	JAN, FEB, MAR, APR, MAY, JUN, JUL, AUG, SEP, OCT, NOV, DEC, or NONE	<p><i>Start month</i></p> <p>This field specifies the first date the connection information is set up in the extended multiprocessor system (XMS) peripheral module (XPM). Enter the month for an actual start date or enter NONE. If NONE is entered, the first date of connection is immediately after the tuple is defined. If the entry is NONE, no refinements require datafill. Go to field ENDDATE.</p>
	DAY	1 to 31	<p><i>Start day</i></p> <p>Enter a value between the range of 1 and 31 corresponding to the day of the month when the connection is first set up.</p>

**TIMESPEC** (continued)**Field descriptions for conditional datafill (Sheet 2 of 3)**

<b>Field</b>	<b>Subfield or refinement</b>	<b>Entry</b>	<b>Explanation and action</b>
	YEAR	1991 to 2103	<i>Start year</i> Enter a value that corresponds to the year when the connection is first set up.
	ENDDATE	see subfields	<i>End date</i> This field consists of subfields ENDMONTH, DAY and YEAR.
	ENDMONTH	JAN, FEB, MAR, APR, MAY, JUN, JUL, AUG, SEP, OCT, NOV, DEC, or NONE	<i>End month</i> Enter the month to specify an actual connection date or enter NONE. If the entry is NONE, no refinements require datafill. Go to field TIMERANG.
	DAY	1 to 31	<i>End day</i> Enter a value that corresponds to the day of the month when the connection is ended.
	YEAR	1991 to 2103	<i>End year</i> Enter a value that corresponds to the year when the connection is ended.
	DAYSWEEK	MON, TUE, WED, THU, FRI, SAT, SUN	<i>Days of the week</i> Enter up to eight days of the week that the connection is set up in the XPM. If less than eight days are required, end the list with a \$ (dollar sign).
	TIMERANG	see subfields	<i>Time ranges</i> This field consists of up to four multiples of subfields STARTIME and ENDTIME. If less than four times are required, end the list with a \$ (dollar sign). The time ranges must be entered sequentially and must not interlap.
	STARTIME	0 to 2400	<i>Start time</i> Enter the start time of a connection in the format HHMM, where HH is 00 to 23 and MM is 00 to 59. The values in fields STARTIME and ENDTIME form a time range of when the semi-permanent connection is active. The start time must be less than the end time.



**TIMESPEC** (continued)**Field descriptions for conditional datafill (Sheet 3 of 3)**

<b>Field</b>	<b>Subfield or refinement</b>	<b>Entry</b>	<b>Explanation and action</b>
	ENDTIME	0 to 2400	<p><i>End time</i> Enter a value to specify the last date a connection is set up in the format HHMM, where HH is 00 to 23 and MM is 00 to 59.</p>
	STATUS	ACTIVE INACTIVE MTC NOINTEGorP MBUSY	<p><i>Status</i> This field indicates the status of the connection. The connection status cannot be set or changed by the operating company. The status is determined by the status of the timed connection (whether it is active or not), and the XPMs involved in the establishment of the connection.</p> <p>ACTIVE - indicates that all connections through PMs and any required network connections are active, and the fields, DAYSWEEK, STARTDAT, ENDDATE, STARTTIME, and ENDTIME indicate that the connection is made at the current time.</p> <p>INACTIVE - a timed entry in table SPECCONN is inactive if one of the PMs has not established a connection, or if the current date is before the start date or after the end date. The entry is also inactive if the current time is not between a start time and end time or if the current day is not found in field DAYSWEEK in table SPECCONN.</p> <p>MTC - indicates that one of the XPMs in a timed entry in table SPECCONN is undergoing a maintenance action.</p> <p>NOINTEG - indicates that the connection has been physically made, but integrity either has not been found or has been lost. Both XPMs are in service.</p> <p>PMBUSY - indicates that at least one of the XPMs in a timed entry in table SPECCONN is out of service.</p>

**Datafill example**

The following example shows sample datafill for table TIMESPEC.

---

**TIMESPEC (end)**

---

**MAP display example for table TIMESPEC**

TIMEIDX	ENDPT1	ENDPT2	STARTDAT	DAYSWEEK	TIMERANG	ABSIG	ENDDATE	DAYS	STATUS
0001	D30			PDTC	1 3 19				
	D30			PDTC	1 2 16	N			
JAN 1 1991							FEB 14 1999		
				(MON)	(TUE)	(WED)	(THU)	(FRI)\$	
				( 0 1200)	(1300 1500)	(1700 2400)\$			ACTIVE
0002	D30			PDTC	1 3 19				
	D30			PDTC	1 2 17	N			
NONE							DEC 25 1999		
						(SAT)	(SUN)\$		
						(0000 2400)\$			INACTIVE

**Table history**  
**BCS34**

Table TIMESPEC was introduced.

**TIMEZONE****Table name**

ITOPS Rating Charge Calculator Time Zone Table

**Functional description**

Table TIMEZONE provides, in minutes, the time difference between the International Traffic Operator Position System (ITOPS) switch time and the time of the calling (originating) party.

Even in cases where the called party is paying for the call, the time used by the ITOPS rating system is the time of the calling party.

For related information, refer to table ATRIMOD.

**Datafill sequence and implications**

There is no requirement to datafill other tables prior to table TIMEZONE.

**Table size**

0 to 64 tuples

**Datafill**

The following table lists datafill for table TIMEZONE.

**Field descriptions**

Field	Subfield or refinement	Entry	Explanation and action
CLGNUM		0 to 9 (up to 18 digits)	Calling number. Enter the numeric digilator string to define a calling number, or a range of calling numbers, which is not in the same time zone as the International Traffic Operator Position System (ITOPS) switch.
SENSE		PLUS or MINUS	Time zone sense. Enter plus or minus to indicate that entry in field TIMEVAL is to be added to or subtracted from the ITOPS switch time to obtain the calling number time.
TIMEVAL		0 to 25	Time zone time amount. Enter the number of half hours to be added to or subtracted from the ITOPS switch time to obtain the calling number time.

**Datafill example**

The following example shows sample datafill for table TIMEZONE.

**TIMEZONE** (end)

---

**MAP display example for table TIMEZONE**

CLGNUM	SENSE	TIMEVAL
9833498349	PLUS	14

---

**TKCVDATA**

---

**Table name**

Mass Trunk Conversion Data Table

**Functional description**

Table TKCVDATA helps operating companies minimize the time and effort to convert per trunk signaling (PTS) trunks to ISDN user part (ISUP) trunks, thereby utilizing the Common Channel Signaling 7 (CCS7) protocol. This table enables the operating company to see what new trunks and trunk groups are created, and can also be used to detect datafill errors.

If the old trunk group is large, the best approach is to split the trunk group into two records. This ensures that the old trunk group can be converted without taking the whole trunk group out of service. During datafill process, it is important that the circuit identification code (CIC) for each trunk is identical at the end switching units. For all Signaling System 7 (SS7) trunks in a switching unit, the CIC must be unique for every destination point code (DPC). Currently, since there are no rules for naming the trunks at the end switching units, the datafill process can be complicated if the external trunk numbers are not aligned at the end switching units.

To determine the CIC assigned to an ISUP trunk, use the following formula:

$$C(x) = n(x) + s - e$$

where

**C(x)**

is the circuit identification code (CIC) for trunk member x

**n(x)**

is the external number for trunk member x in the new trunk group

**s**

is the starting CIC for the set of ISUP trunks in the TKCVDATA record. This is the CIC given to the first ISUP trunk in the set

**e**

is the starting external number for the set of trunks in the new trunk group

Since the external trunk number of the new group determines the CIC value, this assignment ensures that the external trunk numbers of the new group are aligned at the end switching units.

If there are any undatafilled PTS trunks in the record, they appear in the new trunk group as well. There can be some unused CICs. To avoid the holes in

## TKCVDATA (continued)

---

the CICs assigned, the records must be constructed to contain only datafilled trunks.

The records must be datafilled so that the CICs are identical for the trunks at the end switching units. The datafill process is straightforward if the external numbers are identical for the trunks at the end switching units. Two examples are given, at the end of this section, to indicate how the datafill differs depending on the alignment of the external trunk numbers for the trunks at the end switching units.

### Record verification

Each record is verified during datafill and before the conversion is allowed. This verification process checks each of the following rules:

- Both trunk group common language location identifiers (CLLI) are for trunk groups.
- The two trunk group CLLIs are not the same.
- The corresponding subgroup tuples exist in table TRKSGRP for the ISUP trunk group that are in the PTS trunk group.
- The PTS trunk specified by the value in field OSTRTMEM exists (only if not attempting a retry).
- The PTS trunk specified by the value in field OLASTMEM exists (only if not attempting a retry).
- The PTS trunks are on a peripheral module that is specified in table LTCINV as a CCS7 peripheral.
- The set of ISUP trunks datafilled do not exist (only if not attempting a retry), but are valid trunk members.
- The CIC for each new ISUP trunk is not used (only if not attempting a retry), but each is a valid CIC.

The following verifications are already done by standard table control:

- The PTS trunk group CLLI exists.
- The ISUP trunk group CLLI exists.
- The TRKCIC value is within the valid range.
- The selector is CIC.

The overlay of ranges between records is not verified. This can be done manually after all the entries have been added to table TKCVDATA.

---

**TKCVDATA** (continued)

---

The subgroup information is retained in the new ISUP trunks after the conversion. Each new ISUP trunk stays in the subgroup it was in when it was a PTS trunk. The data in each record specifies a block of PTS trunks for conversion.

**MAP level TRKCONV commands**

MAP (maintenance and administrative position) level TRKCONV provides the commands to act on the posted record. The commands available are as follows:

- CVPOST: posts the requested record or records.
- CVBSY: busies out the trunks in the posted record or records. When this command is issued, an alarm goes off when the defined threshold is reached.
- CONV: converts the PTS trunks to ISUP trunks by updating trunk tables.
- CVRTS: brings the trunks into service.
- CVNEXT: displays the next record if more than one record was requested by the CVPOST command.
- CVCOT: runs the continuity test on the trunks.
- UNDO: converts the ISUP trunks back to PTS trunks. This command is not used unless there is something wrong with the conversion process.
- RCLLI: renames the ISUP trunk CLLI to the corresponding PTS trunk CLLI. The PTS trunk CLLI is renamed to a dummy CLLI. This command precludes the use of the UNDO command. This command also changes the conversion status field to LOCKED.
- AUTOCNV: (only with package NTXV25AA [JPN Auto Mass Trunk Conversion]) specifies the particulars of the automatic trunk conversion process.

**Procedure for manual conversion process**

Only one person at one of the affected switching units should perform the conversion process. This person must have access to a remote MAP terminal for the other switching unit involved. A hard copy of table TRKMEM and C7TRKMEM should be taken before the conversion process is started, as a precaution.

## TKCVDATA (continued)

---

The procedure for switching units involved in the process is described below.

1. Check that the switching unit has datafill for CCS7 signaling. If this datafill does not exist, datafill the following tables:
  - C7NETWRK
  - C7LKSET
  - C7LINK
  - C7RTESET
  - IPMLINV (only if message switch and buffer 7 [MSB7] signaling is used)
  - LTCINV (to update field OPT\_ATTR as a CCS7 peripheral module)
2. Check if the ISUP trunk group data exists. If it does not exist, perform the following procedure:
  - a. Add entry to table TRKGRP.
  - b. Add entries to table TRKSGRP.
  - c. Add entries to table ISUPDEST.
  - d. Add translation and routing data for the new ISUP trunk group.
3. Select a block of trunks from a PTS trunk group to convert in consultation with the other switching unit.
4. Add entry to table TKCVDATA for this block of PTS trunks. Various data verifications must be done before this entry can be added in table TKCVDATA (for example, all the PTS trunks reside on a #7 digital trunk controller [DTC]).
5. Set the read-only field CSTATUS to INITIAL.
6. Repeat steps 3 to 5 for any additional blocks of trunks.
7. Go into the TRKCONV MAP level by issuing the following command:  
  

```
> MAPCI;MTC;TRKS;TTP;LEVEL TRKCONV
```
8. Post the record or records agreed on with other switching unit using the CVPOST command. The records posted at both switching units must contain the same trunks.
9. Enter the CVBSY command with the INB option. This changes the state of all the PTS trunks to offline. Log reports are generated for any of the trunks that do not change to the offline state. Correct these logs before continuing.



---

**TKCVDATA** (continued)

---

10. If any of the trunks are in the CPB state, take one of the following actions:
  - Wait for the trunks to go idle, then change them to the offline state using the CVBSY INB command.
  - Go on to another record and come back to this record later.
  - Break the record up into smaller records and isolate the CPB trunks.
11. Ensure that the other switching unit has also issued the CVBSY INB command for the same set of trunks.
12. When all the trunks in the record are in the INB state, the CONV (convert) command can be issued. To convert a record, enter the following command:  
  
    > CONV  
  
    To convert a set of records, enter the following command:  
  
    > CONV ALL
13. The conversion status changes to RUNNING only if the data verifications pass. Otherwise, the command is exited. If the record fails the verification, a verification failure message is displayed on the user's terminal and the command is exited.
14. If the conversion status changes to FAILURE after the command is completed, this indicates that some of the PTS trunks were not converted. Log reports are generated for the trunks that were not converted.
15. If the conversion status changes to COMPLETE after the CONV command is completed, this indicates that all PTS trunks were converted.
16. Ensure that the other switching unit has also converted the same set of trunks.
17. Process all logs generated by the CONV command before proceeding.
18. If the switch is a DMS, issue the CVBSY command. This changes the state of the ISUP trunks to the manual busy state, which is necessary since continuity tests can only be done on trunks in the manual busy or idle states. If the switch is not a DMS, prepare the trunks for continuity tests. Note that the continuity test can only be initiated on outgoing trunks (DMS).

## TKCVDATA (continued)

---

19. The following steps should be performed at the switching unit containing the trunks that are outgoing or two-way:
  - Notify the other switching unit when you are about to start the continuity test. To do this, enter one of the following commands:  
  
    > CVCOT  
  
    or  
  
    > CVCOT ALL
  - If log reports were generated from the continuity tests, they must be corrected in conjunction with the other switching unit.
  - Rerun the CVCOT command if errors existed after the log reports were corrected.
  - When the CVCOT command has completed successfully, bring the new trunks into service by using the CVRTS command.
  - Inform the other switching unit to bring the corresponding ISUP trunks into service.
  - Verify the performance of the new ISUP trunks.
  - This completes the conversion for this record.
20. When the conversion is complete and the PTS trunks are converted successfully, delete the tuples from table TKCVDATA.

### Failure conditions for the manual conversion process

The following procedure is for handling error conditions if the CVCOT command results in several logs.

1. The operating company personnel have the option of fixing the errors or reversing the conversion process. The conversion process can be reversed only if the following conditions are valid.
  - The PTS trunk group data still exists.
  - The conversion status is not set to LOCKED as a result of running the RCLLI command.
2. If the above conditions are met, issue the UNDO command. This deletes the ISUP trunks from tables C7TRKMEM and TRKMEM, and adds the PTS trunks to table TRKMEM.

If a restart occurs during the conversion process, it can result in loss of data. If the data loss cannot be recovered by the software, it is up to the operating company personnel to correct the data inconsistency manually.

---

**TKCVDATA** (continued)

---

**Renaming the ISUP trunk CLLI to the PTS trunk CLLI**

This optional procedure is used if the operating company wishes to reuse the old PTS trunk group CLLI as the ISUP trunk group CLLI (the conversion cannot be reversed with the UNDO command after the ISUP CLLI is renamed).

1. Access the TRKCONV MAP level.
2. Enter the following command:

```
> RCLLI <isup CLLI> <pts CLLI>
```

This changes the CLLI for the ISUP trunk group to the PTS CLLI if the PTS trunk group has no more members and its group data still exists.

3. The PTS CLLI is renamed to a dummy CLLI and it is displayed on the user's terminal if the command was successful. All the records containing either CLLI have the status changed to LOCKED.
4. Remove all the translations for the renamed PTS trunk group.
5. Remove the trunk group data for the renamed PTS trunk group.

The algorithm for assigning the dummy CLLI is as follows: The CLLI name is broken up into two parts -- a string of characters and a numeric part (for example, OLDPTS123). The numeric part is assigned sequentially as required.

**Restrictions and limitations**

Restrictions and limitations concerning datafill of table TKCVDATA are as follows:

- The PTS trunks must be on a peripheral module specified as a CCS7 type.
- Only PTS trunks on digital trunk controllers (DTC), line trunk controllers (LTC), and PCM30 DTCs (PDTC) can be converted to ISUP trunks. No more than 2048 trunk blocks can be specified at a time.
- The CONV, UNDO, and AUTOCONV commands work only if the conversion of PTS trunk members to ISUP trunk members is a one-to-one mapping. If the same PTS or ISUP members are specified in multiple records, the CONV, UNDO, and AUTOCONV commands fail.
- During datafill of table TKCVDATA, no check is made to see if there are any ISUP trunks already datafilled for the range in the record. If there are trunks in the range, it can cause problems when the UNDO command is issued.
- Only the CVPOST, UNDO, RCLLI, and AUTOCONV commands will operate on records of table TKCVDATA with field CONVP set to AUTO.

## TKCVDATA (continued)

---

- The CVPOST command does not allow the user to post a set of records that includes both MAN and AUTO options.
- No check is made to verify that the ISUP trunk group size (as specified by field TRKGRPSIZ in table CLLI) is large enough to accommodate all of the new ISUP members; the operating company personnel must verify that the trunk group size is adequate before trunk conversion is performed.
- Do not schedule or perform external peripheral module (XPM) routine exercise (REX) tests during trunk conversion on affected PMs.
- No check is made to ensure that the trunk group specified in field OLDGRP is a PTS trunk group.
- For records with field CONVP set to AUTO, no check is made to ensure that there is no overlap of trunk members specified in the ranges of OTRKMEM and NTRKMEM.
- Do not perform CM restarts or CM REX during trunk conversion.
- Do not perform an image dump during trunk conversion.
- All ISUP trunk members specified within a record of table TKCVDATA have the same ISUP protocol variant.
- The continuity test performed by the CVCOT command, or during automatic trunk conversion if a continuity test is requested, is dependent on the ISUP trunk type specified in field NEWGRP of the record.
- If the journal file is active, it is updated with the changes to tables TRKMEM, C7TRKMEM, and TKCVDATA during trunk conversion.

### **Datafill sequence and implications**

The following tables must be datafilled before table TKCVDATA:

- CLLI
- C7LINK
- C7LKSET
- C7NETWRK
- C7RTESET
- IPMLINV
- ISUPDEST
- LTCINV
- TRKGRP

**TKCVDATA** (continued)

- TRKMEM
- TRKSGRP

**Table size**

Memory is dynamically allocated up to a maximum of 2048 tuples.

**Datafill**

The following table lists datafill for table TKCVDATA.

**Field descriptions**

Field	Subfield or refinement	Entry	Explanation and action
RECNUM		numeric (0 to 2047)	<i>Record number</i> This field is the key to the table. Enter a record number.
CONVP		MAN or AUTO	<i>Conversion process</i> Enter MAN to select the manual conversion process or AUTO to select the automatic conversion process.
DATA		see subfields	<i>Manual conversion process data</i> If the value in field CONVP is MAN, this field consists of subfields OLDGRP, OSTRTMEM, OLASTMEM, NEWGRP, NSTRTMEM, NLASTMEM, SIGSEL, and CSTATUS.

**TKCVDATA** (continued)**CONVP = MAN**

If the value in field CONVP is MAN, datafill subfields OLDGRP, OSTRTMEM, OLASTMEM, NEWGRP, NSTRTMEM, NLASTMEM, SIGSEL, and CSTATUS as described below.

**Field descriptions for conditional datafill (Sheet 1 of 2)**

Field	Subfield or refinement	Entry	Explanation and action
	OLDGRP	alphanumeric (1 to 16 characters)	<p><i>Old trunk group</i></p> <p>Enter the common language location identifier (CLLI) of the old trunk group that contains the per trunk signaling (PTS) trunks that are being converted to ISDN user part (ISUP) signaling.</p> <p>The entry in field OLDGRP and the entry in field NEWGRP cannot be the same.</p>
	OSTRTMEM	numeric (0 to 9999)	<p><i>Old starting trunk member number</i></p> <p>Enter the starting external trunk member number of the old trunk group.</p>
	OLASTMEM	numeric (0 to 9999)	<p><i>Old last trunk member number</i></p> <p>Enter the last external trunk member number of the old trunk group.</p>
	NEWGRP	alphanumeric (1 to 16 characters)	<p><i>New trunk group</i></p> <p>Enter the CLLI of the new trunk group that contains the ISUP trunks that are being converted from the PTS trunks.</p> <p>The entry in field NEWGRP and the entry in field OLDGRP cannot be the same.</p>
	NSTRTMEM	numeric (0 to 9999)	<p><i>New starting trunk member number</i></p> <p>Enter the starting external trunk member number of the new trunk group.</p>
	CONTMARK	+	<p><i>Continuation mark</i></p> <p>Enter + to indicate that additional information for this tuple is contained in the next record.</p>
	NLASTMEM	numeric (0 to 9999)	<p><i>New last trunk member number</i></p> <p>Enter the last external trunk member number of the new trunk group.</p>

**TKCVDATA** (continued)**Field descriptions for conditional datafill (Sheet 2 of 2)**

<b>Field</b>	<b>Subfield or refinement</b>	<b>Entry</b>	<b>Explanation and action</b>
	SIGSEL	CIC	<i>Signal selector</i> Enter CIC (circuit identification code) and complete refinement TRKCIC.
	TRKCIC	numeric (0 to 16383)	<i>Trunk circuit identification code</i> Enter the trunk CIC for the trunk member. Each CIC must be unique for each destination point code and must be the same between the two switching units as well.
	CSTATUS	INITIAL RUNNING FAILURE COMPLETE or LOCKED	<i>Conversion state</i> Enter INITIAL. After initial datafill, this field is overwritten by the system and becomes a read-only field that indicates the progress of the conversion.

**TKCVDATA** (continued)**CONVP = AUTO**

If the value in field CONVP is AUTO, datafill subfields OLDGRP, OTRKMEM, NEWGRP, NTRKMEM, SIGSEL, CSTATUS, and OPTION as described below.

**Field descriptions for conditional datafill (Sheet 1 of 3)**

Field	Subfield or refinement	Entry	Explanation and action
	OLDGRP	alphanumeric (1 to 16 characters)	<i>Old trunk group</i>  Enter the CLLI of the old trunk group that contains the per trunk signaling (PTS) trunks that are being converted to ISDN user part (ISUP) signaling.  <b>Note:</b> The entry in OLDGRP and the entry in NEWGRP cannot be the same.
	OTRKMEM	see subfields	<i>Old trunk member</i>  This vector field, which consists of up to six multiples of subfields STRTMEM and ENDMEM, indicates up to six ranges that are used to specify the old trunk members requiring conversion.
	STRTMEM	numeric(0 to 9999)	<i>Start member</i>  Enter start value for the range.
	ENDMEM	numeric(0 to 9999)	<i>End member</i>  Enter end value for the range.
	NEWGRP	alphanumeric (1 to 16 characters)	<i>New trunk group</i>  Enter the CLLI of the new trunk group that contains the ISUP trunks being converted from the PTS trunks.  <b>Note:</b> The entry in field NEWGRP and the entry in field OLDGRP cannot be the same.
	CONTMARK	+	<i>Continuation mark</i>  Enter + to indicate that additional information for this tuple is contained in the next record.



**TKCVDATA** (continued)**Field descriptions for conditional datafill (Sheet 2 of 3)**

<b>Field</b>	<b>Subfield or refinement</b>	<b>Entry</b>	<b>Explanation and action</b>
	NTRKMEM	see subfields	<i>New trunk member</i>  This vector field, which consists of up to six multiples of subfields STRTMEM and ENDMEM, indicates up to six ranges that are used to specify the new trunk members requiring conversion.
	STRTMEM	numeric (0 to 9999)	<i>Start member</i> Enter start value for the range.
	ENDMEM	numeric (0 to 9999)	<i>End member</i> Enter end value for the range.
	SIGSEL	CIC	<i>Signal selector</i>  Enter CIC (circuit identification code) and datafill refinement TRKCIC.
	TRKCIC	numeric (0 to 16383)	<i>Trunk circuit identification code</i>  Enter the trunk CIC for the trunk member. Each CIC must be unique for each destination point code and must be the same between the two switching units.  To determine the CIC assigned to an ISUP trunk, use the formula provided on the following page.
	CSTATUS	INITIAL RUNNING FAILURE COMPLETE or LOCKED	<i>Conversion state</i> Enter INITIAL.  After initial datafill, this field is overwritten by the system and becomes a read-only field that indicates the progress of the conversion.

## TKCVDATA (continued)

### Field descriptions for conditional datafill (Sheet 3 of 3)

Field	Subfield or refinement	Entry	Explanation and action
	OPTION	LPBKDN or NIL	<i>Option field</i> If loopback is required, enter LPBKDN to specify the loopback directory number option, and datafill refinement DN. Otherwise, enter NIL.
	DN	numeric (1 to 18 digits)	<i>Directory number</i> Specify the loop-back DN for the continuity test.

### Datafill example

The following example shows sample datafill for table TKCVDATA.

This is an example of physical connections between two switching units that have the same external trunk numbers assigned, as illustrated in the following figure. This type of configuration only requires that one tuple be added to table TKCVDATA at both switching units. The external trunk numbers and the CLI are the same at both ends of the channel.

### Physical connections between two switching units

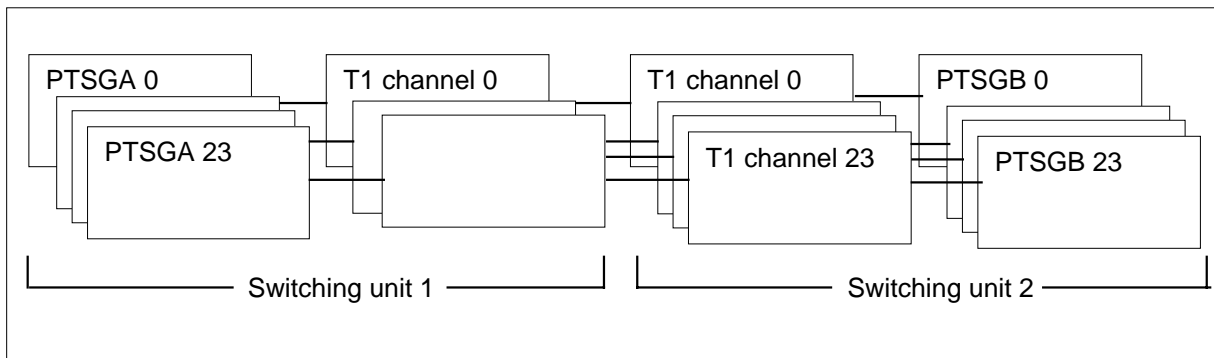

An example of input for switching unit 1 is shown below.

**TKCVDATA** (end)**MAP display example for table TKCVDATA**

RECNUM	CONVP	DATA
1	MAN	PTSGA 0 23 NEWGA 10 33 CIC 50 INITIAL

An example of input for switching unit 2 is shown below.

**MAP display example for table TKCVDATA**

RECNUM	CONVP	DATA
1	MAN	PTSGB 0 23 NEWGB 10 33 CIC 50 INITIAL

**Table history****BCS36**

Dump and restore was changed.

**Supplementary information**

Additional information related to table TKCVDATA is provided below.

**Dump and restore**

As of BCS36, tuples that exist on the dump side in table TKCVDATA are not restored during a BCS upgrade.

## TKFXPT

---

### Table name

Trunk Frame Access Table

### Overview

The following table lists the test access network (TAN) tables.

#### Test Access Network tables

Title of table	Table name
Trunk Frame Access	TKFXPT
Access Relay	ACCRLY
Test Access Network Trunk Test Position Group	TTANTTPG
Test Circuit	TSTCCT
Test Circuit Index	TSTCCTIX

TAN provides a dc metallic test path between a trunk test position (TTP) and any trunk circuit in the office.

Each TAN module is capable of interfacing up to three test trunks (TT) with up to 32 trunk module equipment (TME) frames. Within the module itself, these 32 TME frames are subdivided into four groups of eight frames for provisioning reasons. Metallic access to each of these groups is made possible by the provisioning of up to three relay circuit cards (NT5X01AA) for each group (the actual number of NT5X01AAs depends on the number of TTPs that are to be given metallic access to the TME frames). Each set of NT5X01AAs is called a relay group (it follows from the above that one TAN module provides sufficient room for four such groups). The connection from the TTP to the TAN module is made by means of a test circuit (NT5X02AA). Each test circuit can access up to three TTPs, but only one TTP can use the test circuit for testing at any one time.

These guidelines are further developed by means of the following two cases:

#### **Case 1—how to provide access to more than 32 TME frames**

In the first case where more than four relay groups are required, the solution is simply to provide a second TAN module. As the test circuit connections need only be multiplied from the first TAN module to the second, no additional NT5X02AA test circuit is necessary. This gives the test circuit on the first TAN module metallic access to a total of eight relay groups (64 TME frames). (See note below).

---

**TKFXPT** (continued)

---

**Case 2—how to provide access to more than three TTPs**

In the second case where more than three TTPs are required, the solution is again to provide another TAN module. This time however, the 32 TME frame connections are multiplied from the first TAN module to the second. This module also has the test circuit equipped, as connections between the TAN and a TTP can only be made through an NT5X02AA.

The combination of the above two cases form a TAN matrix. Increases in the number of TME frames takes place along one axis (in units of one relay group and eight TME frames). Likewise, increases in the number of TTPs given access to the TME frames takes place along the other axis (in units of one NT5X02AA and three TTPs).

*Note:* As mentioned above, only one of three TTPs can use a test circuit at any one time. This rule can be circumvented, by provisioning an NT5X02AA test circuit into the second TAN module. This circuit can then be enabled by applying certain options within the TAN tables that can dedicate a specific TTP to a particular test circuit and/or provide hot spare test circuits if one ever fails.

For a complete description of TAN, see the following Northern Telecom publications:

- *DMS-100 Family Commands Reference Manual*
- *Log Report Reference Manual*

**Functional description**

Table TKFXPT defines the relationship of the trunk frame and the cross point in the relay group.

**Datafill sequence and implications**

There is no requirement to datafill other tables prior to table TKFXPT.

**Table size**

Memory is automatically allocated for a maximum of 16 trunk frame types and a maximum of 512 frame numbers for each trunk frame type.

**TKFXPT** (continued)**Datafill**

The following table lists datafill for table TKFXPT.

**Field descriptions**

Field	Subfield or refinement	Entry	Explanation and action
TRKFRAME		see subfields	<i>Trunk frame</i> This field is the key to the table and consists of subfields FRTYPE and FRNO.
	FRTYPE	TME	<i>Frame type</i> Enter TME (trunk module equipment) as the type of frame to which the TAN is to provide access.  An entry outside the range indicated for this field is invalid.
	FRNO	0 to 511	<i>Frame number</i> Enter the number assigned by the operating company to the particular frame that is to be accessed using the test access network (TAN).
XPT		0 to 7	<i>Crosspoint</i> Enter the crosspoint number within a given relay group to which the frame to be accessed is assigned.
NINGRP		0 to 63	<i>Number in group</i> Enter the relay group number to which the frame to be accessed is assigned.

**Datafill example**

The following example shows sample datafill for table TKFXPT.

**MAP display example for table TKFXPT**

TRKFRAME	XPT	NINGRP
TME	0	0

**TKFXPT** (continued)**Supplementary information**

This section provides information on setting up the TAN tables.

**Setup of TAN tables**

The following example shows how to set up the TAN tables for an office.

In this example

- Two TTPs have test access to 10 TME frames.
- The two associated test trunks are assigned on module T8A number 4 circuit 20 and module T8A number 12 circuit 18.

An example of datafill for table TKFXPT is shown below.

**MAP display example for table TKFXPT**

TRKFRAME	XPT	NINGRP
TME	0	0
TME	1	1
TME	2	2
TME	3	3
TME	4	4
TME	5	5
TME	6	6
TME	7	7
TME	8	8
TME	9	9

An example of datafill for table ACCRLY is shown below.

**MAP display example for table ACCRLY**

TLYCCT	MODTYPE	MODNO	MODCKTNO
0	0	TAN	0
0	1	TAN	4
1	0	TAN	1
1	1	TAN	5

An example of datafill for table TTANTTPG is shown below.

**TKFXPT (end)**

**MAP display example for table TTANTTPG**

TTPNO	TMTYPE	TMNO	TMCKTNO	RELPT
0	T8A	4	20	0
1	T8A	12	18	1

An example of datafill for table TSTCCT is shown below.

**MAP display example for table TSTCCT**

INDEX	MODTYPE	MODNO	MODCKTNO
0	TAN	0	15

An example of datafill for table TSTCCTIX is shown below.

**MAP display example for table TSTCCTIX**

TCCTINDX	INDEX
0	0
1	0



**TKMTRNAM****Table name**

Trunk Meter Names Table

**Functional description**

This table, which specifies the external character string associated with a trunk software meter, lists up to five trunk meter names. Meter name NILMETER must be in this table, and is automatically added by the metering system. NILMETER is the default name used for unassigned trunk software meters. The remaining four names are used for specifying call processing charges.

**Datafill sequence and implications**

Table LNETWORK must be datafilled before table TKMTRNAM.

With the exception of table LNETWORK, table TKMTRNAM must be datafilled before any of the other metering tables.

**Table size**

1 to 5 tuples

**Datafill**

The following table lists datafill for table TKMTRNAM.

**Field descriptions**

Field	Subfield or refinement	Entry	Explanation and action
METERNAM		alphanumeric (up to 16 characters)	<i>Meter name</i> Enter the name of the trunk software meter. The meter name NILMETER is automatically added to this table by the system.

**Datafill example**

See table LNETWORK for an example of datafill for table TKMTRNAM.

## TKSIGSYS

---

### Table name

Trunk Signaling System Table

### Functional description

Table TKSIGSYS enables additional signaling parameters to be datafilled for a trunk subgroup. For trunk subgroups that use a signaling type that is supported by table TKSIGSYS, each tuple in table TKSIGSYS is referenced by an index in table TRKSGRP.

Tuples in table TKSIGSYS contains parameters for a specific signaling system. Most of these parameters are timers associated with specific signals. Trunk subgroups associated with different trunk groups can use not only the same signaling system, but also the same set of signaling parameters. This is accomplished by having each trunk subgroup tuple reference the same tuple in table TKSIGSYS (through the use of field TKICSSI or TKOGSSI in table TRKSGRP).

Field TKSIGTYP in table TKSIGSYS specifies the signaling type. The signaling type determines the parameters contained in the rest of the tuple. At present, the only signaling type supported in table TKSIGSYS is NTTMF, which is for Japan DMS-100 interexchange trunks (IET).

Datafill changes to table TKSIGSYS for signaling type NTTMF do not take effect immediately for all fields. To ensure that the modified data is downloaded to the PCM30 digital trunk controllers (PDTC), manually busy and then return to service all PDTCs associated with the affected trunk subgroups. This can be accomplished using any one of the following methods:

- Busy and return to service either the active unit or the entire peripheral module (PM).

*Note:* If the active unit is busied when both units are running in synchronization, a warm restart switch of activity (WARMSWACT) is performed on the inactive unit. The WARMSWACT does not result in the downloading of the new parameters.

- Perform a cold restart switch of activity (COLDSWACT) on all affected PDTCs.
- Busy and return to service all affected trunks. Operating company personnel must determine which trunk subgroups are affected by the change or changes to a given tuple in table TKSIGSYS.

The busy and return to service action is not necessary if changes are only made to fields for which changes take effect immediately (that is, on subsequent new

**TKSIGSYS** (continued)

calls). Refer to the field description section of this document for a list of fields for which the result of datafill modification is immediate.

*Note:* The default values for this table are not recommendations. They may not be acceptable for a specific switching unit's applications.

**Datafill sequence and implications**

Table TKSIGSYS must be datafilled before table TRKSGRP.

**Table size**

0 to 255 tuples

**Datafill**

The following table lists datafill for table TKSIGSYS.

**Field descriptions (Sheet 1 of 2)**

Field	Subfield or refinement	Entry	Explanation and action
TKSIGIDX		alphanumeric (1 to 16 characters)	<i>Trunk signaling index</i> This is the key field to table TKSIGSYS. Enter a name from field TKICSSI or TKOGSSI of table TRKSGRP to serve as an index into table TKSIGSYS.
TKSSVAR		see subfield	<i>Trunk signaling system variable area</i> This field consists of subfield TKSIGTYP and refinement.
	TKSIGTYP	NTTMF	<i>Trunk signaling type</i> Enter NTTMF and datafill refinement DIRDATA. The NTTMF signaling type is applicable to Japan DMS-100 interexchange trunks (IET).
	DIRDATA	see subfield	<i>Trunk direction specific data</i> This field consists of subfield DIR and refinements.
	DIR	IC or OG	<i>Trunk direction</i> If the direction of traffic flow on the trunk group is incoming, enter IC and datafill refinements SRATDEL, RMAXKPD, RMINCLF, RCLFDEL, RMAXDGDL, and TRDENBL as described in section DIR = IC, table "Field descriptions for conditional datafill"..

**TKSIGSYS** (continued)**Field descriptions (Sheet 2 of 2)**

Field	Subfield or refinement	Entry	Explanation and action
			<p>If the direction of traffic flow on the trunk group is outgoing, enter OG and datafill refinements RMINRAT, RMINPTS, SMAXKP, SADRDEL, SMAXDIG, SDIGDEL, SDGCMPLT, SMAXST, RMXPTSDEL, and RRLCDEL as described in section DIR = OG, table "Field descriptions for conditional datafill"..</p> <p>The entry in this field must be the same as the entry in field DIR of tables TRKGRP and TRKSGRP for the associated trunks.</p>

**DIR = IC**

If the value in field DIR is IC, datafill refinements SRATDEL, RMAXKPD, RMINCLF, RCLFDEL, RMAXDGDL, and TRDENBL as described below.

**Field descriptions for conditional datafill (Sheet 1 of 2)**

Field	Subfield or refinement	Entry	Explanation and action
SRATDEL		numeric (0 to 255)	<p><i>Send register attached delay</i> Enter the time duration, in units of 10 ms, that the incoming trunk waits following detection of seizure before responding by a sending a register-attached signal to the calling switching unit. The default value is 0 (zero).</p>
RMAXKPD		numeric (1 to 40)	<p><i>Receive maximum key pulse delay</i> Enter the maximum time duration, in units of 1 s, between the transmission of the register-attached signal and the reception of the key pulse (KP) signal. The default value is 10 (10 s).</p> <p>Changes to this field take effect immediately.</p>
RMINCLF		numeric (2 to 255)	<p><i>Receive minimum clear forward</i> Enter the minimum time duration, in units of 10 ms, that a received clear forward signal must be maintained to be recognized. The default value is 27 (270 ms).</p> <p>Changes to this field take effect immediately.</p>

**TKSIGSYS** (continued)**Field descriptions for conditional datafill (Sheet 2 of 2)**

<b>Field</b>	<b>Subfield or refinement</b>	<b>Entry</b>	<b>Explanation and action</b>
RCLFDEL		numeric (1 to 40)	<i>Receive clear forward delay</i> Enter the time duration, in units of 1 s, between the transmission of a clear back signal and the reception of a clear forward signal. If the timer expires without a clear forward signal being received from the preceding switching unit, the trunk goes into the lockout state. The default value is 1 (1 s).
RMAXDGDL		numeric (1 to 40)	<i>Receive maximum digits delay</i> Enter the maximum time duration, in units of 1 s, between the end of the KP signal and the end of the stop (ST) signal for receiving the address digits. The default value is 20 (20 s). Changes to this field take effect immediately.
TRDENBL		Y or N	<i>Timed release disconnect enable</i> If the timed release disconnect (TRD) timer, specified by office parameter LONG_TIMED_RELEASE_DISC_TIME in table OFCENG, is enabled, enter Y (yes). Otherwise, enter N (no).  Setting the value to N also disables the receive clear forward delay (RCLFDEL) timer. The default value is Y.  Changes to this field take effect immediately.

**TKSIGSYS** (continued)**DIR = OG**

If the value in field DIR is OG, datafill refinements RMINRAT, RMINPTS, SMAXKP, SADRDEL, SMAXDIG, SDIGDEL, SDGCMPLT, SMAXST, RMXPTSDL, and RRLCDEL as described below.

**Field descriptions for conditional datafill (Sheet 1 of 2)**

Field	Subfield or refinement	Entry	Explanation and action
	RMINRAT	numeric (2 to 255)	<i>Receive minimum register attached</i> Enter the minimum time duration, in units of 10 ms, that a received register attached (RAT) signal must be maintained to be recognized. The default value is 7 (70 ms).  Changes to this field take effect immediately.
	RMINPTS	numeric (2 to 255)	<i>Receive minimum proceed to send</i> Enter the minimum time duration, in units of 10 ms, that a received proceed to send (PTS) signal must be maintained to be recognized. The default value is 7 (70 ms).  Changes to this field take effect immediately.
	SMAXKP	numeric (4 to 255)	<i>Send maximum key pulse</i> Enter the maximum duration, in units of 10 ms, that the key pulse (KP) signal will be maintained while waiting to receive the PTS signal. The default value is 100 (1 s).
	SADRDEL	numeric (3 to 255)	<i>Send address delay</i> Enter the time, in units of 10 ms, between the reception of the PTS signal and the transmission of the first digit of the address. The default value is 16 (160 ms).  Changes to this field take effect immediately.
	SMAXDIG	numeric (5 to 255)	<i>Send maximum digits</i> Enter the maximum duration, in units of 10 ms, of each digit pulse. The default value is 7 (70 ms).
	SDIGDEL	numeric (3 to 255)	<i>Send digit delay</i> Enter the duration, in units of 10 ms, of the interdigital pause. The default value is 3 (30 ms).

**TKSIGSYS** (end)**Field descriptions for conditional datafill (Sheet 2 of 2)**

Field	Subfield or refinement	Entry	Explanation and action
	SDGCMPLT	numeric (3 to 255)	<i>Send digit completion</i> Enter the duration, in units of 10 ms, between the last address digit and the ST signal. The default value is 3 (30 ms).
	SMAXST	numeric (5 to 255)	<i>Send maximum ST</i> Enter the maximum pulse duration, in units of 10 ms, of the ST signal. The default value is 7 (70 ms).
	RMXPTSDL	numeric (1 to 40)	<i>Receive maximum proceed-to-send delay</i> Enter the maximum time duration, in units of 1 s, that an outgoing trunk waits for the PTS signal after sending the seizure signal. The default value is 10 (10 s).  Changes to this field take effect immediately.
	RRLCDEL	numeric (20 to 255)	<i>Receive release complete delay</i> Enter the time duration, in units of 10 ms, to wait for the release complete (RLC) signal after sending the clear forward (CLF) signal. The default value is 100 (1 s).

**Datafill example**

The following example shows sample datafill for table TKSIGSYS.

This example shows two tuples, one for incoming trunks and one for outgoing trunks.

**MAP display example for table TKSIGSYS**

TKSIGIDX	TKSSVAR
NTTMFIC1	NTTMF IC 0 10 27 1 20 Y
NTTMFOG1	NTTMF OG 7 7 100 16 7 3 3 7 10 100

## TKTONODE

---

### Table name

DCR Trunk Groups from DCR Offices Table

### Functional description

Table TKTONODE contains the trunk group common language location identifier (CLLI) of incoming and two-way dynamically controlled routing (DCR. For DCR purposes, a tuple contains the name of the switch from which the incoming trunk group originates and the DCR network name to which this node belongs (for related information, refer to table DESTKEY).

For DCR purposes, any incoming trunk group not found in this table or datafilled without information pertaining to DCR is considered to be a non-DCR trunk group.

### Datafill sequence and implications

The following tables must be datafilled before table TKTONODE:

- TRKGRP
- DCRNETID
  
- DESTKEY

### Table size

Table TKTONODE is dynamically allocated using SEGSTOR facilities. A maximum of 64K elements can be found in the table.



**TKTONODE** (continued)**Datafill**

The following table lists datafill for table TKTONODE.

**Field descriptions**

Field	Subfield or refinement	Entry	Explanation and action
TKKEY		see subfield	<i>TKTONODE key</i> Enter the datafill for subfield CLLI.
	CLLI	alphanumeric (1 to 16 characters)	<i>Dynamically controlled routing trunk group CLLI</i> Enter the common language location identifier (CLLI) for each DCR group.
NETINFO		see subfield	<i>Network information</i> Datafill subfield DCXSELEC and the corresponding refinements.
	DCXSELEC	DCR	<i>Dynamically controlled system selection</i> Enter DCR for DCR information. If DCR is entered, datafill refinement DCRNET and ICFROM.
	DCRNET	alphanumeric (1 to 12 characters)	<i>Network name</i> Enter the DCR network name of the DCR incoming node.
	ICFROM	alphanumeric (1 to 16 characters)	<i>Destination node name</i> Enter the DCR destination office CLLI to specify the destination switch from which the trunk group is incoming.

**Datafill example**

The following example shows sample datafill for table TKTONODE.

## TKTONODE (end)

---

### MAP display example for table TKTONODE

TKKEY	NETINFO
ISUPITIC	(DCR DCRNETWORK1 NODE1) \$
ISUPITIC2	(DCR DCRNETWORK2 NODE2) \$

### Table history

#### NA004

Field NETINFO was added for DCA. Subfield DCXSELEC was added with additional refinements. Refinement NETNAME was changed to DCRNET, and refinement DCANET was added.

#### NA003

Changes were made in the way table TKTONODE physical store is allocated. It is now dynamically allocated and independent of table TRKGRP.

#### BCS36

Field NETNAME was added for multiple network access.

#### BCS54

Set of values for field DCXSELEC was changed fro {DCR, DCA} to {DCR only}.

**TLCLORIG****Table name**

TOPS Local Originator

**Functional description**

TLCLORIG assigns a local calling zone name to the call based on the A-party (calling) number. The local calling zone is assigned on the basis of the incoming trunk group and calling party number, and provides a grouping based on the call originator.

**Datafill sequence and meaning**

Enter datafill into table TLCLZONE before table TLCLORIG.

**Table size**

0 to 32767 tuples

Memory is allocated in blocks of 128 words. Each tuple uses 4 words.

**Datafill**

The table that follows lists datafill for table TLCLORIG.

**Field descriptions (Sheet 1 of 2)**

Field	Subfield	Entry	Explanation and action
LOCLKEY		see subfields	Local key. This field is the key to the table and consists of subfields LOCLZONE, FROMDIGS and TODIGS.
	LOCLZONE	name from TLCLZONE	Local calling zone name. Enter the initial zone name assigned in table TRKGRP, field LOCLZONE and defined in table TLCLZONE.
	FROMDIGS	up to 18 digits	From digits. Enter the starting number of the range of the calling digits.  This subfield is a digilator, similar to subtable STDPRTCT.STDPRT. Therefore, it is not possible to datafill two tuples that begin with the same digits and have different digit lengths. For example, tuples 23 23 and 231 231 cannot be used in the same table.

**TLCLORIG (end)**

**Field descriptions (Sheet 2 of 2)**

Field	Subfield	Entry	Explanation and action
	TODIGS	up to 18 digits	To digits. Enter the ending number of the range of the calling digits. This subfield is a digilator like subfield FROMDIGS.
NEWZONE		name from TLCLZONE	New local calling zone name. This field assigns a new local calling zone name to replace the original name in field LOCLZONE.

**Datafill example**

The figure that follows shows sample datafill for table TLCLORIG.

**MAP display example for table TLCLORIG**

LOCLKEY	NEWZONE		
-----			
LOCLZONE1	3221	3225	LOCLZONE2
LOCLZONE1	13122	13127	LOCLZONE3

**Table history**

**TOPS14**

This table was created by feature 59015886 in functionality GOS Local Determination, GOS00001.

**Additional information**

None

**TLCLSCRN****Table name**

TOPS Local Screening

**Functional description**

TLCLSCRN specifies the destination (called) number that is local. This specification is determined on the basis of the local calling zone name assigned to the call originator and the digits of the destination (called) number.

**Datafill sequence and meaning**

Enter datafill into table TLCLZONE before table TLCLSCRN.

**Table size**

0 to 342767

Memory is dynamically allocated in blocks of 256 words. Each tuple uses 6 words.

**Datafill**

The table that follows lists datafill for table TLCLSCRN.

**Field descriptions (Sheet 1 of 2)**

Field	Subfield	Entry	Explanation and action
LOCLKEY		see subfields	Local key. This field is the key to the table and consists of subfields LOCLZONE, FROMDIGS and TODIGS.
	LOCLZONE	name from TLCLZONE	Local calling zone name. Enter a name defined in table TLCLZONE.

**TLCLSCRN** (end)

**Field descriptions (Sheet 2 of 2)**

Field	Subfield	Entry	Explanation and action
	FROMDIGS	up to 18 digits	From digits. Enter the starting number of the range of the called digits.  This subfield is a digilator, similar to subtable STDPRTCT.STDPRT. Therefore, it is not possible to datafill two tuples that begin with the same digits and have different digit lengths. For example, tuples 23 23 and 231 231 cannot be used in the same table.
	TODIGS	up to 18 digits	To digits. Enter the ending number of the range of the called digits. This subfield is a digilator like subfield FROMDIGS.

**Datafill example**

The figure that follows shows sample datafill for table TLCLSCRN.

**MAP display example for table TLCLSCRN**

LOCLKEY		
-----		
LOCLZONE2	511	515
LOCLZONE3	13444	13447

**Table history**

**TOPS14**

This table was created by feature 59015886 in functionality GOS Local Determination, GOS00001.

**Additional information**

None

**TLCLZONE****Table name**

TOPS Local Zone

**Functional description**

TLCLZONE defines the valid local calling zone names that are used by other tables. These local calling area zone names provide groupings of the call originators based on the calling party number.

**Datafill sequence and meaning**

After table TLCLZONE, enter datafill in tables TRKGRP and TOPSPARM.

**Table size**

1 to 8192 tuples

Memory is dynamically allocated in blocks of 256 words. Each tuple uses 2 words.

**Datafill**

The table that follows lists datafill for table TLCLZONE.

**Field descriptions**

Field	Subfield	Entry	Explanation and action
LOCLZONE		up to 32 alphanumeric characters	Local zone. Define a local calling zone name for use in other tables for GOS Local Determination.

**Datafill example**

The figure that follows shows sample datafill for table TLCLZONE.

**MAP display example for table TLCLZONE**

```

LOCLNAME
-----
NLCL
LOCLZONE1
LOCLZONE2
LOCLZONE3

```

**TLCLZONE** (end)

---

**Table history**

**TOPS14**

This table was created by feature 59015886 in functionality GOS Local Determination, GOS00001.

**Additional information**

None



## TMINV

---

### Table name

Trunk Module Inventory Table

### Functional description

Table TMINV lists the following assignment data for each trunk module (TM):

- TM module type and number
- floor, row, bay position, and base mounting position of each TM
- frame type and number on which the TM is physically mounted
- network assignments
- product engineering code (PEC) of the TM
- the load name of peripheral module (PM) software
- the set of executive programs required for the TM
- single card conference trunk module (compact)
- single card enhanced digital recording announcement machine (EDRAM)
- analog interface module (AIM)

*Note:* For BCS35 and up, EDRAM control information is stored in table TMINV. Prior to BCS35, this information was stored in table EDRAMINV. For further information, refer to table EDRAMINV.

The peripheral processor executive program lineup maintenance trunk module (MTM) audio tone detectors (MTMATD) support all basic MTM functions, including audio tone detection. The basic MTM functions include all circuits that are provisionable on an MTM or service trunk module (STM), except digital data line cards, dual-tone multifrequency (DTMF) senders, and transmission test trunks.

The MTMATD executive program is designed to replace the MTM250 executive program lineup in a non-DMS-250 environment. All offices supporting Integrated Business Network (IBN) and requiring audio tone detectors must use this executive program lineup instead of the MTM250 executive program lineup. The MTMATD executive program does not support DMS-250 receivers.

The MTMEX executive program for the cabinetized Meridian SL-100 no longer allows package trunk modules (PTM). PTMs have been discontinued by the manufacturer. PTMs that are datafilled as PTMs in table TMINV cause International 101 test lines to fail. PTMs must be datafilled as MTMs to avoid this problem.

For BCS36 and up, a new TM/MTM shelf is introduced. The controller card for the ISM shelf is NTFX42AA; however, the integrated service module (ISM) can be used as an empty shelf, having no controller card or power supply. An empty ISM shelf is used exclusively to host single-card PMs such as conference trunk modules (CTM) and digital trunk modules (DTM).

If the MTM does not use the ISM shelf, the audio tone detector card (NT5X29AC) increases the size of the MTMATD executive program lineup, resulting in the need for an updated version of the MTM processor card. Since the current executive program lineup is close to the maximum storage that is available in the MTM, it is important to check the size of the executive program lineup being used. If the executive program lineup exceeds 2 kbyte, either a new processor card (NT0X70AC) or the NT4X65AB controller card is required. This card increases the executive program store from 2 to 16 kbyte.

If the NT0X70AC processor card or the NT4X65AB controller card is used, the MTM must be loaded with the remote MTM (RMTM) load. This load allows the NT0X70AC processor card and the NT4X65AB controller card to access the extra 14 kbyte of executive program store.

### **Provisioning EDTUs in MTMs or ISMs**

The Enhanced Digital Test Unit (EDTU) provides the functionality of the Transmission Test Trunk (TTT), the Transmission Test Unit (TTU) and/or the Digital Test Unit (DTU). The card code for the EDTU is NT4X45AA and it occupies one slot position in an MTM or an ISM shelf.

The following rules apply to provisioning of EDTUs in MTMs or ISMs:

- The EDTU card has its own load, the downloading is done from the TTP level of the MAP display.
- The EDTU is a four-channel circuit pack. The next slot to the right is left vacant in MTM shelves. In ISM shelves, the next slot to the left is left vacant.

- The TTU- and DTU-based EDTU can be used in MTM or ISM shelves wherever the original TTUs and DTUs were provisioned before the EDTU was introduced.
- The TTT-based EDTU requires an executive program lineup change for the MTM or ISM that the TTT-based EDTU is installed in. In addition, the following provisioning restrictions apply:
  - domestic applications
    - Enter MTMDT in table TMINV field EXEC for the MTM or ISM.
    - Reload the peripheral module.

*Note:* If the entry in table TMINV field EXEC is MTMDT, the MTM or ISM does not support the following trunks:

    - office alarm packs NT3X82, NT3X83, NT3X84, NT3X85, NT0X10, and NT2X57
    - digital recorded announcement machines NT1X75, NT1X76, NT1X77, and NT1X79
    - coin receivers NT3X08AA and NT3X08AB
  - international applications
    - Enter IMTMDT in table TMINV field EXEC for the MTM or ISM.
    - Reload the peripheral module.

*Note:* If the entry in table TMINV field EXEC is IMTMDT, the MTM or ISM does not support the following trunks:

    - office alarm packs NT3X82, NT3X83, NT3X84, NT3X85, NT0X10, and NT2X57
    - digital recorded announcement machines NT1X75, NT1X76, NT1X77, and NT1X79
    - coin receivers NT3X08AA and NT3X08AB
    - TTTs NT1X90 and NT2X96

## Datafill sequence and implications

The following tables must be datafilled before table TMINV.

- NETWORK
- ENCDINV

## Table size

0 to 1024 tuples

Memory is automatically allocated in segmented blocks. Each block can accommodate 16 TMs. The maximum number of TMs is 2048. Only 512 conference trunk modules (CTM) can be datafilled.

## Datafill

The following table lists datafill for table TMINV.

### Field descriptions

Field	Subfield or refinement	Entry	Explanation and action
TMNM		see subfields	<i>Trunk module number</i> This field consists of the subfields TMTYPE and TMNO.
	TMTYPE	AIMCTMDTM MTMOAURS MSTMT8ATM 2TM4TM8	<i>Trunk module type</i> Enter one of the following trunk module (TM) types: <ul style="list-style-type: none"> <li>• AIM (analog interface module)</li> <li>• CTM (conference trunk module)</li> <li>• DTM (enhanced digital recording announcement machine [EDRAM] TM)</li> </ul> <p>This field must be set to "DTM" for Audiogram Delivery Services (ADS) announcements because ADS announcements are only supported by EDRAM. Refer to the Audiogram Delivery Services-Offer of Service Prompts functionality (ENSV0013) in the Table history section of this document.</p> <ul style="list-style-type: none"> <li>• MTM (maintenance trunk module)</li> <li>• OAU (office alarm unit)</li> <li>• RSM (remote service module)</li> <li>• STM (service TM)</li> <li>• T8A (gateway TM)</li> <li>• TM2 (TM 30 pair)</li> <li>• TM4 (TM 60 pair)</li> <li>• TM8 (TM 120 pair)</li> </ul>

## Field descriptions

Field	Subfield or refinement	Entry	Explanation and action
	TMNO	0 to 2047 0 to 255 or 0 to 99	<p><i>Trunk module number</i></p> <p>Enter the number of the TM datafilled in field TMTYPE.</p> <p>If the entry in field TMTYPE is CTM, DTM, AIM, T8A, TM2, TM4, or TM8, enter a value from 0 (zero) to 2047.</p> <p>If the entry in field TMTYPE is MTM or STM, enter a value from 0 (zero) to 255.</p> <p>If the entry in field TMTYPE is OAU, enter 0 (zero).</p> <p>If the entry in field TMTYPE is RSM, enter a value from 0 (zero) to 99.</p>
FRTYPE		ISME MCAM MCGM MCPM MCSM PCSM RLCM RSE or TME	<p><i>Frame type</i></p> <p>Enter one of the following frame types:</p> <ul style="list-style-type: none"> <li>• ISME (Integrated service module equipment)</li> <li>• MCAM (Meridian cabinet auxiliary module)</li> <li>• MCGM (Meridian cabinet general module)</li> <li>• MCPM (Meridian cabinet power module)</li> <li>• MCSM (Meridian cabinet service module)</li> <li>• PCSM (packaged core service module)</li> <li>• RLCM (remote line concentrating module)</li> <li>• RSE (remote service equipment)</li> <li>• TME (TM equipment)</li> <li>• Any entry outside the range of indicated values for this field is invalid.</li> </ul>
FRNO		0 to 511	<p><i>Frame number</i></p> <p>Enter the number of the frame on which the TM is mounted.</p>

## Field descriptions

Field	Subfield or refinement	Entry	Explanation and action
SHPOS		0 to 77	<p><i>Shelf position</i> Enter the base mounting position of the TM.</p> <p>If the entry in field TMTYPE is T8A, TM2, TM4, or TM8, enter 04, 18, 32, 51, or 65.</p> <p>If the entry in field TMTYPE is CTM, DTM, or AIM, enter 65.</p> <p>If the entry in field TMTYPE is MTM or STM, enter 65.</p> <p>If the entry in field TMTYPE is OAU, enter 51.</p> <p>If the entry in field TMTYPE is RSM, enter 18, 32, 51, or 65.</p> <p>Any entry outside the range of indicated values for this field is invalid.</p>
FLOOR		0 to 99	<p><i>Floor</i> Enter the floor or remote location where the TM equipment frame is located.</p>
ROW		A to Z or AA to ZZ, (except I, II, O, or OO)	<p><i>Row</i> Enter the row in which the TM equipment frame is located.</p>
FRPOS		0 to 99	<p><i>Frame position</i> Enter the bay position of the TM equipment frame.</p>
LKDATA		see subfields	<p><i>C-side link data</i> For switches that are equipped with the junctored network (JNET), this field consists of subfields NMPAIR and NMPORT.</p> <p>For switches that are equipped with the enhanced network (ENET), this field consists of subfields ENSHELF, ENSLOT, ENLINK, and ENDS30.</p>

**JNET switches**

For switches that are equipped with the JNET, datafill subfields NMPAIR and NMPORT as described in the following table, then go to field EQPEC, section

“All switches”, table “Field descriptions”, to continue datafill for table TMINV.

#### Field descriptions for conditional datafill

Field	Subfield or refinement	Entry	Explanation and action
	NMPAIR	0 to 31	<i>Network module number</i> If the entry in field TMTYPE is CTM, DTM, AIM, MTM, OAU, STM, T8A, TM2, TM4, or TM8, enter the network module number assigned to the TM.  If the entry in field TMTYPE is RSM, enter 0 (zero).
	NMPORT	0 to 63	<i>Network module port</i> If the entry in field TMTYPE is CTM, DTM, AIM, MTM, OAU, STM, T8A, TM2, TM4, or TM8, enter the network module port number assigned to the TM.  If the entry in field TMTYPE is RSM, enter 0 (zero).  Go to field EQPEC, section “All switches”, table “Field descriptions”, to continue datafill.

#### ENET switches

For switches that are equipped with the ENET, datafill subfields ENSHELF, ENSLOT, ENLINK, and ENDS30 as described in the following table, then go to field EQPEC, section “All switches”, table “Field descriptions”, to continue datafill for table TMINV.

#### Field descriptions for conditional datafill

Field	Subfield or refinement	Entry	Explanation and action
	ENSHELF	0 to 7	<i>ENET shelf number</i> Enter the shelf number to which the PM is assigned.
	ENSLOT	10 to 16 25 to 32 or 13 to 19	<i>ENET slot number</i> For the crosspoint slot number of the PM, enter a value between 10 and 16 or 25 and 32.  For a DMS SuperNode SE switching unit, enter a value between 13 and 19.

**Field descriptions for conditional datafill**

<b>Field</b>	<b>Subfield or refinement</b>	<b>Entry</b>	<b>Explanation and action</b>
	ENLINK	0 to 18	<i>ENET link number</i> Enter the link on the crosspoint to which the PM is assigned.
	ENDS30	0 to 15	<i>ENDS30</i> Enter a value from 0 (zero) to 15 for fiber links.  This field defaults to 0 (zero) if the link is a DS-30.  All entries must be contiguous from 0 (zero). No entry can be duplicated.  Go to field EQPEC, section "All switches", table "Field descriptions", to continue datafill.



**All switches**

For all switches, datafill fields EQPEC, LOAD, and EXECS as described in the following table.

**Field descriptions**

Field	Subfield or refinement	Entry	Explanation and action
EQPEC		FX4101 FX42AA 1X80AA 1X80BA 1X81AA 1X81BA 2X52AA 2X52AB 2X52AC 2X52AD 2X52AE 2X52AF 2X52AG 2X52AK 2X52AL 2X52AM 2X52AN 2X52AP 2X52AR 2X52CA 2X52CB 2X58AA 2X58AB 2X58AC 2X58AD 2X58AE 2X58AG 2X58AK 2X58AL 2X58AM 2X58AT 2X58AU 2X58BA FX46AA	<p><i>Equipment product engineering code</i></p> <p>Enter the product engineering code (PEC) of the TM.</p> <p>If the entry in field TMTYPE is CTM, enter 1X81AA or 1X81BA.</p> <p><b>Note:</b> NT1X81AA and NT1X81BA must not coexist in the same office. If EQPEC is datafilled as 1X81AA, then 1X81BA must be removed and vice versa. 1X81BA is used for the Japanese market only.</p> <p>If the entry in field TMTYPE is DTM, enter 1X80AA or 1X80BA (EDRAM). For EDRAM applications, enter 1X80AA or 1X80BA.</p> <p><b>Note:</b> This field must be set to "1X80AA" for ADS announcements because ADS announcements are only supported by EDRAM. Refer to the Audiogram Delivery Services-Offer of Service Prompts functionality (ENSV0013) in the Table history section of this document.</p> <p>For T8A in DMS-300 offices, enter FX4101, FX42AA, or 2X52CB.</p> <p>For TM2 in DMS-300 offices, enter FX4101 or FX42AA, or 2X52AA or 2X52AE (2X52AA is replaced by 2X52AE).</p> <p>If the entry in the field TMTYPE is AIM, enter FX46AA.</p>

## Field descriptions

Field	Subfield or refinement	Entry	Explanation and action
		2X58CA 2X58CB 2X58CC 2X58CF	If the entry in field TMTYPE is TM4, enter FX4101 or FX42AA, or 2X52AB or 2X52AF (entry 2X52AB is replaced by 2X52AF).
		2152SA 2158SA 2158SB2158S	If the entry in field TMTYPE is TM8, enter FX4101 or FX42AA, or 2X52AC or 2X52AG (entry 2X52AC is replaced by 2X52AG).
		C 6X13AA 7X3001 7X3004	For Canadian operating company offices with TM8, enter FX4101, FX42AA, or 2X52AP.
		or 7X3501	For Canadian operating company offices with TM2, enter FX4101, FX42AA, or 2X52AM.
			For Canadian operating company offices with TM4, enter FX4101, FX42AA, or 2X52AN.
			For private branch exchange (PBX) and IBN offices with T8A and TM8 combinations, enter FX4101, FX42AA, 2X52AG, or 2X52AP.
			For DMS-300 international gateway offices with T8A, enter FX4101, FX42AA, 2X52AD, or 2X52AR.
			If the entry in field TMTYPE is MTM, enter FX4101, FX42AA, or 2X58AA or 2X58CA (2X58CA replaces 2X58AA).
			For MTM with DRA systems, enter FX4101, FX42AA, 2X58AG, 2X58AK, 2X58AL, or 2X58CB (2X58AK replaces 2X58AG and 2X58CB replaces 2X58AK).

**Field descriptions**

Field	Subfield or refinement	Entry	Explanation and action
			<p>For Canadian operating company offices with MTM, enter 2X58AL. If the MTM uses the ISM shelf enter FX4101 or FX42AA.</p> <p>For the MTM/Caribbean expansion program (MTM/CEP), enter 2X58CC. If the MTM uses the ISM shelf enter FX4101 or FX42AA.</p> <p>If the entry in field TMTYPE is OAU, enter FX4101, FX42AA, 2X58AB, 2X58AD, or 2X58AF.</p> <p>If the entry in field TMTYPE is RSM, enter FX4101, FX42AA, 2X58AE, 2X58CF.</p> <p>For the STM shelf assembly, enter FX4101, FX42AA, 7X3001, or 7X3004.</p> <p>For the package switch (PTM) shelf assembly, enter FX4101, FX42AA, 7X3501.</p> <p>Any entry outside the range of indicated values for this field is invalid.</p> <p><b>Note:</b> The following card codes have been discontinued by the manufacturer by BCS35:            NT2X58AA, NT2X58AB, NT2X58AC, NT2X58AD, NT2X58AE, NT2X58AG, NT2X58AK, NT2X58AN, NT2X58AR, NT2X58AS, and NT2X58AW.</p>

## Field descriptions

Field	Subfield or refinement	Entry	Explanation and action
LOAD		alphanumeric (vector of up to 8 characters)	<i>Load</i> Enter the loadfile name of the PM software.
EXECS		AMTMEX ATMEX CMTMEX DDLCEX IMTMDT IMTMEX MTM250EX MTM300 MTMATD MTMDT MTMEX MTM1EX MTMTTT OAUEx T8A300 T8AEX TANEX TM2EX TM4EX TM8EX, UKECEX, UKMTM or UKTMEX	<i>Executive programs</i> Enter the set of executive programs required for the TM.  To ensure inband digits delivery, MTM1EX must be downloaded to MTMs which host the digit receivers. The downloading of exec_lineup to the MTMs must be done as part of USNBD setup process to ensure Inband Digit Collection capability.  If the new exec_lineup is not downloaded to the MTMs, the inband digit delivery functionality does not work. A PM126 log indicating 'PM PROTOCOL ERROR' is generated.

**TMTYPE = any entry other than CTM, DTM, or AIM**

If the entry in field TMTYPE is any entry other than CTM, DTM, or AIM, datafill is complete for table TMINV after entering SHELF in field TMVARIANT as described in the following table.

**TMTYPE = CTM or DTM**

If the entry in field TMTYPE is CTM or DTM, datafill additional refinement TMVARIANT as described in the following table.

**Field descriptions for table TMINV conditional datafill for a single card TM**

Field	Subfield or refinement	Entry	Explanation and action
	TMVARIANT	SINGLE_ CARD	<p><i>Trunk module location</i> Enter SINGLE_CARD if the TM is a single card TM (only CTM and DTM are single card TMs) and datafill refinements LOC_TM_TYPE, LOC_TM_NUMBER, and LOC_SLOT_NUMBER. Otherwise, enter SHELF. No other datafill is required.</p> <p>The corresponding prompt for this field is TM_SELECTOR_TYPE.</p>
	LOC_TM_ TYPE	MTM MMA STM or NIL	<p><i>Single card trunk module location: host module shelf type</i> If the entry in field TMTYPE is CTM, enter MTM or STM.</p> <p>If the entry in field TMTYPE is DTM, enter MTM, MMA, or STM.</p>
	LOC_TM_ NUMBER	0 to 2047	<p><i>Single card trunk module location: host module shelf number</i> Enter the external PM number of the shelf containing the CTM or DTM.</p> <p>The default value for this field is 0 (zero).</p>
	LOC_SLOT_ NUMBER	0 to 37	<p><i>Single card trunk module location: card position</i> Enter the card position, or slot number, within the shelf of the CTM or DTM.</p> <p>The default value for this field is 5.</p>

**TMTYPE = AIM**

If the entry in field TMTYPE is AIM, datafill additional refinement TMVARIANT as described in the following table.

**Field descriptions for table TMINV conditional datafill for two card TM**

Field	Subfield or refinement	Entry	Explanation and action
	TMVARIANT	COMPACT	Enter COMPACT if the TM is a two card TM (only AIM is a two card TM) and datafill refinements LOC_TM_TYPE, LOC_TM_NUMBER, LOC_SLOT_NUMBER, and B_CARD_EQUIPMENT. Otherwise, enter SHELF. No other datafill is required.  The corresponding prompt for this field is TM_SELECTOR_TYPE.
	LOC_TM_TYPE	MTM TM or NIL	<i>Two card trunk module location: host module shelf type</i> If the entry in field TMTYPE is AIM, enter MTM or TM.  The default value for this field is NIL.
	LOC_TM_NUMBER	0 to 2047	<i>Two card trunk module location: host module shelf number</i> Enter the card position, or slot number, within the shelf of the AIM.  The default value for this field is 0.
	LOC_SLOT_NUMBER	0 to 37	<i>Two card trunk module location: card position</i> Enter the card position, or slot number, within the shelf of the AIM.  The default value for this field is 5.
	B_CARD_EQUIPMENT	FX48AA FX15AA	<i>Equipment code of AIM card B (mate card)</i> Enter FX48AA or FX15AA.

**Datafill example**

The following example shows sample datafill for table TMINV.

**MAP display example for table TMINV**

EXECS	TMNM	FRTYPE	FRNO	SHPOS	FLOOR	ROW	FRPOS	LKDATA	EQPEC	LOAD
			SCTMLOC							
MTMEX	MTM	0	PCPM SHELF	0	32	0	A	0	0 55	7X3501 MTMKA02
MTMEX	MTM	1	PCPM SHELF	0	18	0	A	0	3 27	7X3501 MTMKA02
MTMEX	STM	0	PCSM SHELF	0	4	0	C	4	0 7	7X3004 MTMKA02
MTMEX	STM	1	PCSM SHELF	0	4	0	C	4	2 4	7X3004 MTMKA02
MTMEX	DTM	0	PCPM SINGLE_CARD	0	51	0	C	4	0 25	1X80AA EDRMAC07
				MTM		4	10			
MTMEX	DTM	1	PCPM SINGLE_CARD	0	51	0	C	4	0 26	1X80AA EDRMAC07
				MTM		4	11			
MTMEX	AIM	1	MTM COMPACT	0	12	3	D	1	0 55	FX46AA MTMKA02
				MTM		4	12			FX48AA AIMKA01

**Table history**  
**CSP18**

Added information for MTM1EX for CR Q00493295.

**TL06**

Added information for AIM and for NT1X80BA and NT1X81BA cards.

**NA005**

Feature AN1542 in the functionality Audiogram Delivery Services-Offer of Service Prompt functionality (ENSV0013) introduces announcements that are only supported by EDRAM. The TMTYPE subfield and the EQPEC field are updated to reflect this requirement.



**CSP05**

The following changes were made to table TMINV:

- added information about provisioning EDTUs in MTMs and ISMs
- added entries MTMDT and IMTMDT to field EXEC for EDTUs

**BCS36**

The following changes were made to table TMINV:

- deleted all references to trunk module type TRCC
- added value ISME (integrated service module equipment) to field FRTYPE and PEC entries FX4101 and FX42AA to field EQPEC, and modified section "Functional description of table TMINV" in accordance with feature AR0918
- deleted all references to value AVTMEX in field EXECS

**TMSOCDL****Table name**

TOPS Message Switch Operator Centralization Data Link Group Table

**Functional description**

Table TMSOCDL associates a data link with a TMS, DS-1/PCM-30 port and channel number. Also the level of the LAPD protocol parameters and the OCDL (EISP) number for each Operator Centralization via Enhanced TOPS Message Switch (ETMS OC) data link is datafilled in this table.

**Datafill sequence and implications**

Tables LTCINV, LTCPSINV, and OCDLGRP must be datafilled before table TMSOCDL. Datafill table OCGRP after table TMSOCDL.

**Table size**

0 to 256 tuples

A maximum of 32 data links can be defined for each data link group name defined in table OCDLGRP. However, a maximum of 256 data links can be defined in an entire office.

**Datafill**

The following table lists datafill for table TMSOCDL.

**Field descriptions (Sheet 1 of 2)**

Field	Subfield or refinement	Entry	Explanation and action
OCDLKEY		see subfields	Operator Centralization Data Link Key. This field consists of subfields OCDLGRP and DLINDEX.
	OCDLGRP	as defined in table OCDLGRP	Operator Centralization Data Link Group. Enter the OC data link group for this data link.
	DLINDEX	0 to 31	Data Link Index. Enter the data link number within the data link group.

**TMSOCDL** (continued)**Field descriptions (Sheet 2 of 2)**

PROTLEVEL	LOW, MEDIUM, or HIGH	<p>Protocol Level. Enter the level of the LAPD parameters for the data link:</p> <ul style="list-style-type: none"> <li>• LOW: This setting can be used for relatively small (&lt;1000 miles) land based connections and good link conditions (i.e., minimal CRC (Cyclical Redundancy Check) errors) between endpoints.</li> <li>• MEDIUM: This setting can be used for longer (&lt;3000 miles) land based connections and fair to good link conditions between endpoints.</li> <li>• HIGH: This setting can be used for very long (&gt;3000 miles) land or satellite based connections and good conditions between endpoints.</li> </ul>
TMS	0 to 255	TOPS Message Switch. Enter the TMS number for the data link.
PORT	0 to 19 for an ETMS with DS-1 I/F cards.  0 to 15 for an ETMS with PCM-30 I/F cards.	Port. Enter the DS-1 or PCM-30 port number on the TMS specified above for the data link.
CHANNEL	1 to 24 for an ETMS with DS-1 I/F cards.  1 to 15 and 17 to 31 for an ETMS with PCM-30 I/F cards.	Channel. Enter the channel on the DS-1 or PCM-30 port above for the data link.
OCDL	0 to 14 and 16 to 31	Operator Centralization Data Link. Enter which OCDL (EISP channel) is selected for this data link on the specified TMS. This number is used to perform maintenance on the data link in the new OCDL level of MAPCI.

**TMSOCDL** (end)**Datafill example**

The following example shows sample datafill for table TMSOCDL.

**MAP display example for table TMSOCDL**

OCDLKEY		PROTLEVEL	TMS	PORT	CHANNEL	OCDL
CARYDL1	0	HIGH	1	5	11	0
CARYDL1	1	HIGH	0	2	9	0
RALEIGHDL1	0	LOW	0	8	13	1
RALEIGHDL1	1	LOW	1	1	2	2
DURHAMDL1	0	MEDIUM	1	7	8	1
DURHAMDL1	1	MEDIUM	0	19	24	2

**Table history****TOPS04**

Table introduced by feature AN1133 in functionality Enhanced TOPS OC and OC Remote Support, ENSV0008 and ENSV0011.

## TMSPSDEV

### Table name

TOPS Message Switch P-Side Device

### Functional description

Table TMSPSDEV is used for datafilling Traffic Operator Position System (TOPS) message switch (TMS) peripheral-side (P-side) devices such as directory assistance (DA) and operator reference database (ORDB). Channels on eight different DS-1 links can be specified for each device.

Table TMSPSDEV contains the following information:

- device identification
- TMS P-side ports and channels

### Datafill sequence and implications

There is no requirement to datafill other tables prior to table TMSPSDEV.

not applicable

### Table size

0 to 511 tuples

### Datafill

The following table lists datafill for table TMSPSDEV.

#### Field descriptions (Sheet 1 of 2)

Field	Subfield or refinement	Entry	Explanation and action
DEVNAME		see subfields	Device name. This field consists of subfields DEVID and DEVNO.
	DEVID	DA or ORDB	Device identifier. Enter the type of peripheral-side (P-side) device up to 16 characters in length.
	DEVNO	0 to 254	Device number. Enter the device number.
TMSNO		0 to 255	Traffic operator position system message switch number. Enter the number of the Traffic Operator Position System (TOPS) message switch (TMS).  A check is made to ensure that the TMS is not datafilled in table LTCINV with field OPTATTR = OC.

**TMSPSDEV** (continued)**Field descriptions (Sheet 2 of 2)**

Field	Subfield or refinement	Entry	Explanation and action
CKTTAB		see subfields (vector of up to 8)	Circuit table. This field contains link information for the device and consists of subfields CKTNO and CKTTSTAB.
	CKTNO	0 to 19	Circuit number. Enter the TMS P-side link the device is connected to.
	CKTTSTAB	see subfield	Circuit time slot table. This subfield consists of subfield CKTSEL.
	CKTSEL	ALL or CHNLS	Circuit selector. Enter ALL if all of the channels on a link are used. Enter CHNLS if a subset of the channels is used.
	CKTTSTAB	1 to 24 (vector from 1 to 31)	Circuit time slot table. If the entry in subfield CKTSEL is CHNLS, datafill this refinement. Enter up to 31 channels used for a device on a particular link. If less than 31 channels are required, end the list with a \$ (dollar sign).  For DS-1 channels, the range is 1 to 24.  For D30 (TMS with pulse code modulation 30 [PCM30]), the range is 1 to 15, and 17 to 30.

**Datafill example**

The following example shows sample datafill for table TMSPSDEV.

**MAP display example for table TMSPSDEV**

DEVNAME	TMSNO	CKTTAB
DA	201	40
(0 ALL )		
(1 CHNLS ( 1) (2) (12) (20) \$) \$		

**Table history**  
**TOPS04**

Added note to field TMSNO that table LTCINV is checked for OC optional attribute per feature AN1133 in functionality Enhanced TOPS OC and Enhanced Remote Support, ENSV0008 and ENSV0011.

## **TMSPSDEV** (end)

---

### **BCS36**

Dump and restore procedures were added.

### **Supplementary information**

This section provides information on dump and restore procedures when datafilling table TMSPSDEV.

#### **Dump and restore**

If upgrading from BCS33 and prior to BCS34 and up, field CKTTSTAB must be expanded to accomodate 32 timeslots. In all other cases, normal dump and restore applies.

---

**TMSPVC**

---

**Table name**

TOPS Message Switch Permanent Virtual Circuit Table

**Functional description**

Table TMSPVC contains datafill for every Traffic Operator Position System (TOPS) message switch (TMS) on the switch, and the permanent virtual circuits (PVC) used by each TMS.

Prior to BCS35, this table is read-only. From BCS35 and up, this table can be modified by the operating company. Tuples can be added, deleted, or changed to reflect the number of PVC layouts used by a given TMS.

**Datafill sequence and implications**

Table PVCTYPE must be datafilled before table TMSPVC.

Table TDCDEF must be datafilled after table TMSPVC.

**Datafill guidelines**

Use the following guidelines when datafilling table TMSPVC.

The table key for each entry must include a type defined in table PVCTYPE (for example, TPC 100 STD).

Each directory assistance (DA), terminal position controller (TPC), central control (CC), and operator reference database (ORDB) PVC layout defined against a table key entry must contain a type defined in table PVCTYPE.

*Example:*

```
TPC 100 STD      (4 DA 100 STD 1) (5 ORDB 100 CGI4 1)
```

Always use the following numbering scheme for TPC entries:

- Ensure the version is a three-digit number.
- Number the primary data links from 100 to 123.
- Number the secondary data links from 200 to 223, making 200 the secondary link to 100, 201 the secondary link to 101, and so on.



## TMSPVC (continued)

---

Always use the following numbering scheme for DA entries:

- Use the first digit of the two-digit version number to represent the DA link on the D-channel handler (DCH) card.
- Use the second digit of the two-digit version number to represent the number of the DCH card.

*Example:*

DA 21 STD

*where*

**21**

is the second DA link on DCH card 1

Always use the following numbering scheme for ORDB entries:

- Use the first digit of the three-digit version number to indicate whether the link connects to the actual database (use digit 1) or to another DCH channel (use digit 2).
- Use the second digit of the three-digit version number to indicate from which DCH the link originates.
- Use the third digit of the three-digit version number to indicate on which DCH the link terminates.

**Note:** If the link is a direct database link, the third digit should be the same as the second digit.

*Example:*

ORDB 100 CGI4

*where*

**100**

represents a direct database link from DCH card 0

### Table size

0 to 65 tuples

**TMSPVC** (continued)**Datafill**

The following table lists datafill for table TMSPVC.

**Field descriptions (Sheet 1 of 2)**

Field	Subfield or refinement	Entry	Explanation and action
PVCKEY		see subfields	Permanent virtual circuit key. This field consists of subfields CTYPE, VERSION, and CONFIG.
	CTYPE	CC, DA, ORDB, or TPC	Configuration type. Enter the TOPS message switch (TMS) P-side device as follows: <ul style="list-style-type: none"> <li>• CC for central controller</li> <li>• DA for directory assistance</li> <li>• ORDB for operator reference database</li> <li>• TPC for terminal position controller</li> </ul>
	VERSION	0 to 255	Version. Enter the version of the configuration.
	CONFIG	alphabetic (up to 7 characters)	Configuration layout. Enter the text string corresponding to the permanent virtual circuit (PVC) layout type, as defined in table PVCTYPE.
PVCTAB		see subfields	Permanent virtual circuit table. This field consists of subfields NUMPVCS, CTYPE, VERSION, CONFIG, and PURPOSE.
	NUMPVCS	0 to 1024	Number of private virtual circuits. Enter the number of PVCs.
	CTYPE	CC, DA, ORDB, or TPC	Configuration type. Enter the destination device as follows: <p>CC for central controller</p> <p>DA for directory assistance</p> <p>ORDB for operator reference database</p> <p>TPC for terminal position controller</p>
	VERSION	0 to 255	Version. Enter the version of the destination configuration. Entry value 0 (zero) signifies that any version of the destination configuration is supported.

**TMSPVC** (end)

**Field descriptions (Sheet 2 of 2)**

Field	Subfield or refinement	Entry	Explanation and action
	CONFIG	alphabetic (up to 7 characters)	Configuration layout type. Enter the text string corresponding to the PVC layout type, as defined in table PVCTYPE.
	PURPOSE	0 to 255	Purpose. Enter the type of communication used by the PVC.
CONTMARK		+ or \$	Continuation mark. Enter + to indicate that additional information for this tuple is contained in the next record. Otherwise, enter \$ to indicate the end of the tuple.

**Datafill example**

The following example shows sample datafill for table TMSPVC.

**MAP display example for table TMSPVC**

```

PVCKEY
PVCTAB
-----
DA 100      STD
(4 TPC 100 STD 0) (4 TPC 102 STD 2) (4 TPC 165 STD 15) $

ORDB 100    STD
(5 TPC 100 STD 0) (5 TPC 101 STD 1) (5 TPC 100 STD 0)
(5 TPC 101 STD 1) (5 ORDB 201 CGI4 10) $

TPC 100     STD
(4 DA 100 STD 0) (5 ORDB 100 CGI4 0) (1 CC 0 DMS 0)
(4 CC 0 DMS 1) $
    
```

---

**TMTCNTL**

---

**Table name**

Treatment Control Table

**Functional description**

The subtables of the Treatment Control Table are listed below:

- TMTCNTL.TREAT (EXTTMTNM = OFFTREAT)
- TMTCNTL.TREAT (EXTTMTNM = ITTRKGRP)
- TMTCNTL.TREAT (EXTTMTNM = INTRKGRP)
- TMTCNTL.TREAT (EXTTMTNM = LNT)
- TMTCNTL.TREAT (EXTTNTNM = TITRKGRP)
- TMTCNTL.TREAT (EXTTMTNM = PXTRKGRP)
- TMTCNTL.TREAT (EXTTMTNM = TOPS)
- TMTCNTL.TREAT (EXTTMTNM = AOSSTKGP)
- TMTCNTL.TREAT (EXTTMTNM = INT101TT)
- TMTCNTL.TREAT (EXTTMTNM = PRIVLNTT)

As detailed in the description of subtable TMTCNTL.TREAT, the table TMTCNTL field EXTTMTNM entry use is predetermined by the software packages available in the switch. All EXTTMTNM values appear in the switch as valid entries. The entries appear in all software loads of a BCS vintage because the EXTTMTNM values are a part of the DMS base software.

**Datafill sequence and implications**

There is no requirement to datafill other tables prior to table TMTCNTL.

The following tables must be datafilled after table TMTCNTL:

- HNPACONT.HNPACODE
- TMTCNTL.TREAT
- TMTMAP

**Table size**

0 to 2048 tuples

## TMTCNTL.TREAT

---

### Table name

Treatments Subtable

### Functional description

The Treatments Subtable (TMTCNTL.TREAT) is used by the operating company to define the treatment that is returned to the originator of a call if a specified treatment code is encountered during call translation. A treatment is one of the following:

- Tone
- Announcement
- State, for example, IDLE or LOCKOUT, or
- Combinations of Tones, Announcements or States

Remote Message Indicator (RMI) modifies subtable TMTCNTL.TREAT as follows:

- RMIA treatment is added to the range of values for the TREATMT field.
- RMID treatment is added to the range of values for the TREATMT field.

Treatment codes are a set of DMS-defined mnemonics. Refer to "Description of treatment codes" in this table description for further details.

A call terminates in a specified treatment code either because the translations that are supplied by the operating company lead the call to a specified treatment, or because the DMS switch detects certain conditions and prescribes a treatment code without reference to operating company translations. These conditions make it impossible to complete the call (for example, all trunks busy). The treatment code can be part of a normal call completion process that includes, for example, an announcement to the originator before the call is completed.

Refer to the section "Operational measurements treatment categories" in this table description for a logical grouping of treatment codes.

If the call must terminate in a specified treatment code, call translations accesses the subtable TMTCNTL.TREAT to determine the announcement or tone to be returned to the originator, or the route in table OFRT that lists the sequence of announcements or tones, or both.

Individual TMTCNTL.TREAT tables do not list all the possible treatment codes. The DMS switch has to access several TMTCNTL.TREAT subtables

---

**TMTCNTL.TREAT** (continued)

---

until it encounters the prescribed treatment code result. The order for determining the result of the treatment code is as follows:

1. Search for a treatment code in the subtable at a position relevant to the originator of call (for example, position LNT for calls that originated from subscriber line). Refer to TREATMENT SUBTABLE POSITIONS in this table description for a description of available subtable positions.
2. Search for the treatment code in the subtable at position OFFTREAT.
3. Search for treatment code RODR in the subtable at position OFFTREAT.
4. Apply IDLE (dial tone returned to originator).

Treatment results for lines terminate after a prescribed sequence of announcement(s), tone(s) or both for the following:

- LOCKOUT: line sounds dead to the originator
- IDLE: dial tone is returned to the originator
- ROH: receiver off-hook tone is returned to the originator

Calls that originate from by trunks must never terminate to LOCKOUT, IDLE or ROH. Table TMTCNTL.TREAT at position OFFTREAT, (consulted last in order of precedence), must never contain ROH, IDLE, or LOCKOUT values; and the subtable at position OFFTREAT must list treatment results that are common to all trunk group types.

*Note:* See treatment GNCT on how to avoid a potential looping situation.

If an Integrated Business Network (IBN) line is call processing busy (CPB) and encounters an all-trunks-busy condition, the line status displays NIL.

The type of switch determines the TMTCNTL.TREAT subtable and treatment code used in a specific switch.

If a switch type is not listed against a treatment, the treatment is redundant in that switch and must be set to overflow or similar tone.

### **Datafill sequence and implications**

The following tables must be datafilled before table TMTCNTL.TREAT.

- DNINV
- DNROUTE

---

**TMTCNTL.TREAT** (continued)

---

**Table size**

0 to 256 tuples. Two tuples are added to TMTCNTL.TREAT to describe RMIA and RMID treatments.

**Switch types**

The table below lists switch types that are used in this description.

**Switch types**

Type	Designation	Description
Local	DMS-100	Local
Toll	DMS-200	Toll
Local/Toll	DMS-100 DMS-200 DMS-100/200	Local, Toll, Combined Local/Toll
TOPS	DMS	Traffic Operator Position System
Gateway	DMS-300	International Gateway for North America
Tandem	DMS-250	Tandem Switch for Common Carriers
ISDN	DMS	Integrated Services Digital Network
ETSI ISDN	DMS-100E	European Integrated Services Digital Network

**Signaling system 7**

Table TMTMAP is accessed before table TMTCNTL where treatment occurs on a call incoming on a CCS7 trunk group with table TRKSGRP field SIGDATA set to C7UP and field PROTOCOL set to a protocol name found in table TMTMAP field PROTOCOL. Table TMTCNTL is accessed only if table TMTMAP field TMTPROC is set to LOCAL for that treatment.

Refer to the description of table TMTMAP.

**Note:** Treatment code mnemonics for all office types are defined in the DMS switch base software. This means that all offices at a particular software release can see all of the treatment mnemonics available, even though the features do not exist to use them properly.

**TMTCNTL.TREAT** (continued)

The operating company should note that this document does not cover treatment mnemonics for the following switching systems:

- DMS-MTX
- DMS-250
- GSM

**Operational measurements treatment categories**

Refer to the *Operational Measurements Reference Manual* for a description of separation of call treatments into logical categories and the corresponding separation of operational measurement (OM) registers into groups TRMTCU, TRMTCU2, TRMTCU3, TRMTCM, TRMTCM2, TRMTER, TRMTFR, TRMTFR3, TRMTFR2, TRMTRS, and TRMTPR.

**TRMTCU, TRMTCU2 and TRMTCU3—customer unauthorized treatments**

The customer unauthorized treatments (listed in the table that follows) notify customers that their actions are not authorized for one of the following reasons:

- an invalid sequence of digits was dialed, or
- improper procedures were followed.

**TRMTCU, TRMTCU2 and TRMTCU3—customer unauthorized treatments  
(Sheet 1 of 4)**

<b>Treatment mnemonic and number</b>	<b>Treatment description</b>
AARD	Automatic number identification (ANI) account recently disallowed
ADBF 65	ANI not found in database
ANBB 107	ANI Feature Group B blockage
ANIA 76	ANI account status not allowed
ATHF	Authentication failure
BBFS 132	Blue box fraud scanning
BCNI 161	Bearer capability not implemented
CACB 124	Carrier access code blocked
CACE 79	Carrier access code in error
CCCF 149	Carrier call completion failure



**TMTCNTL.TREAT** (continued)**TRMTCU, TRMTCU2 and TRMTCU3—customer unauthorized treatments  
(Sheet 2 of 4)**

<b>Treatment mnemonic and number</b>	<b>Treatment description</b>
CCIR 141	Credit card invalid release
CCNA 91	Calling card not allowed
CCNV 90	Calling card invalid
CGFL 154	ISDN closed user group call failed
CNAC 113	Call not accepted
CNDT 5	Coin denied termination
CNOT 55	Coin overtime
COSX 123	Class of service exceeded
DACD 84	Dial carrier access code
DCFC 56	Disallowed coin-free call
DNTR 33	Denied terminating
DODT 61	Denied origination data terminal
D950 80	Dial 950
EROR	Enhanced roamer validation (ERV) originator
ERTO	ERV timeout
ERTR	ERV terminator
ESNF	Customer unauthorized electronic serial number (ESN) fraud
FACJ	Facility rejected
FDNZ 88	First digit not zero
FNAL 68	Feature not allowed
GFNV	Global fiber optic network card (FONCARD) not valid
HNPI 16	Home NPA intercept

**TMTCNTL.TREAT** (continued)**TRMTCU, TRMTCU2 and TRMTCU3—customer unauthorized treatments  
(Sheet 3 of 4)**

<b>Treatment mnemonic and number</b>	<b>Treatment description</b>
ICCB	Incoming call barred within closed user group (CUG)
IDPB 112	International direct distance dialing (DDD) prohibited
ILRS 82	Inter-LATA restriction
INAC 4	Invalid account code
INAU 53	Invalid authorization code
INCC 97	Invalid city code
INPD 110	Invalid personal identification number (PIN) digits
ITCF 164	Information transfer capability request invalid
IVCC 108	Invalid corridor call
JACK 163	Justified alternate calling knowledge
LCAB 96	Local call area barred
LCNV 53	Local exchange carrier (LEC) calling card not valid
MSCA 7	Misdirected centralized automatic message accounting (CAMA) call (prefix digit dialed in error)
MSLC 8	Misdirected local calls (prefix digit not dialed)
MSOA	Misdirected operator-assisted announcement (0+ dialing not allowed)
NACD 83	Do not dial carrier access code
NACK 78	Negative acknowledgment
NOCN 50	No coin
NPAR 111	NPA restricted
N00B 120	N00 call blocked
N950 81	Do not dial 950
ORSS 27	Originating service suspension

**TMTCNTL.TREAT** (continued)**TRMTCU, TRMTCU2 and TRMTCU3—customer unauthorized treatments (Sheet 4 of 4)**

<b>Treatment mnemonic and number</b>	<b>Treatment description</b>
PTFL 156	POTS pseudo service call failed
RDIR	Maximum number of redirections
RSDT 63	Restricted date and time
SCUN 109	Service currently unavailable
TDND 21	Toll denied
TESS 28	Terminating service suspension
TINV 54	Temporarily invalid authorization code
UCCN 144	Unpaid credit card number
UNCA 13	Unauthorized CAMA call
UNIN 22	Unauthorized INWATS call
UNMC	User not member of closed user group (CUG)
UNOW 20	Unauthorized OUTWATS call
VPFL 155	ISDN virtual private network (VPN) call failed

**TRMTCM and TRMTCM2—customer miscellaneous treatments**

These customer miscellaneous treatments (listed in the table that follows) are call situations that are a result of customer action but are not related to authorization. They do not include treatments that are used to mark progress or completion of call features.

**TRMTCM AND TRMTCM2—customer miscellaneous treatments (Sheet 1 of 3)**

<b>Treatment mnemonic and number</b>	<b>Treatment description</b>
ANCT 31	Machine intercept
ANTO 66	Answer time out
ATBS 59	Attendant busy

**TMTCNTL.TREAT** (continued)**TRMTCM AND TRMTCM2—customer miscellaneous treatments (Sheet 2 of 3)**

<b>Treatment mnemonic and number</b>	<b>Treatment description</b>
ATDT 106	Audio tone detector (ATD) time out
BLDN 18	Blank directory number
CBTN 114	Clearback tone
CFWV 77	Variable call forwarding verification
CHAF 118	Changed 800 number forward
CHAN 117	Changed 800 number announcement
CNAD 137	Call not allowed
CREJ 132	Call rejected
DISC 45	Disconnect timing
MTBL	Mobile trouble
NTRS 133	No terminal responding
NC8F 128	Network Control System (NCS) 800 service failure
N9DF 146	NCS 900 database failure
N9NS 148	NCS 900 number not in service
N9OB 147	NCS 900 number out of band
OPRT 29	Regular intercept
OSVR 119	Operator services voice response
PDIL 2	Partial dial time out
PSIG 3	Permanent signal time out
RING 162	No terminal responding, release call
CCRG	Cumulative charge restriction for general subscribers
CCRH	Cumulative charge restriction for PHS (Personal) subscribers
CCRM	Cumulative charge restriction for mobile subscribers

**TMTCNTL.TREAT** (continued)**TRMTCM AND TRMTCM2—customer miscellaneous treatments (Sheet 3 of 3)**

<b>Treatment mnemonic and number</b>	<b>Treatment description</b>
CCRP	Cumulative charge restriction for general subscribers
CCRT	Cumulative charge restriction for third party billed calls
PODN	Ported out directory number
TDBR 62	Test desk bridged
TRBL 30	Trouble intercept
UNDN 17	Unassigned directory number
UNDT 0	Undefined treatment
UPAB 135	Universal public access blocked
VACS 65	Vacant speed number
VACT 6	Vacant code treatment
VCCT 95	Vacant country code treatment
VPFX 138	Vacant prefix code

**TRMTER—equipment-related treatments**

These equipment-related treatments (listed in the table that follows) are failures that are a result of switching equipment malfunction, and do not include treatments used to handle software or hardware resource shortages.

**TRMTER—equipment-related treatments (Sheet 1 of 2)**

<b>Treatment mnemonic and number</b>	<b>Treatment description</b>
AIFL 87	Autoidentified outward dialing failure
ANFL 116	Announcement fail
CONP 98	Connection not possible
C7AP 130	CCS7 application failure treatment
DTFL 131	Datafill error

**TMTCNTL.TREAT** (continued)**TRMTER—equipment-related treatments (Sheet 2 of 2)**

<b>Treatment mnemonic and number</b>	<b>Treatment description</b>
ERDS 70	Trunk PERM ground
FDER 92	Feature data error
INBT 127	Installation busy treatment
INOC 75	Invalid operator code
INVM 169	Invalid message
MTOC 115	Multifrequency compelled (MFC) time out or confusion
NCUN 105	Network Control System (NCS) unexpected error
NMZN 67	No metering zone
NONT 104	Not on network
PERR 168	Protocol error
PNOH 32	Permanent signal no receiver off-hook
PTOF 64	Premature trunk offering
RODR 25	Reorder
SCFL 100	Database system (DBS) communications failure
SONI 170	Service option not implemented
SSTO 23	Start signal time out
STOB 71	Signal time out, Bell operating companies (BOC)
STOC 72	Signal time out, inter-LATA or international carrier (IC/INC)
SYFL 14	System failure

**TRMTFR, TRMTFR2 and TRMTFR3—feature-related treatments**

These feature-related treatments (listed in the table that follows) are a result of call situations due to certain call features, such as POTS, IBN, and so on. They

**TMTCNTL.TREAT** (continued)

do not include treatments used to deny access to features for authorization reasons.

**TRMTFR, TRMTFR2, and TRMTFR3—feature-related treatments (Sheet 1 of 3)**

<b>Treatment mnemonic and number</b>	<b>Treatment description</b>
ACPR 140	AUTHCODE prompt
ACRJ 166	Anonymous caller rejection
ADPA 142	Address digits prompt announcement
AIND 203	Advanced Intelligent Network Disconnect
AINF 204	Advanced Intelligent Network Final
BUSY 19	Busy line
CBDN 145	Call back destination number
CCAP 139	Credit card announcement prompt
CCDT 143	Credit card dial tone
CCTO 89	Calling card time out
CFOV 121	Call forwarding overflow
CONF 38	Confirm tone
CRTC	Call redirect
DSCN 176	Spontaneous Call Waiting Identification with Disposition (DSCWID) disconnect (DISCON)
FRDR 129	Feature reorder
ICNF 151	Invalid conference code
ICSA	In call service activated
ICSD	In call service deactivated
IIEC	Feature related; invalid information element component
ILRR 122	International line restrictions
ISAX	In session activation exit

**TMTCNTL.TREAT** (continued)**TRMTFR, TRMTFR2, and TRMTFR3—feature-related treatments (Sheet 2 of 3)**

<b>Treatment mnemonic and number</b>	<b>Treatment description</b>
IWUC 126	International wake-up call
LBSY 178	LCL busy
LDAA 211	Long distance signal activate added
LDAD 212	Long distance signal activate deleted
LECV 152	Local exchange carrier (LEC) calling card valid
MANL 26	Manual line
MHLD 60	Music on hold
MWKP	Mobile weak power
NCII 102	Network Control System (NCS) invalid ID code
NCIX 101	NCS incoming exclusion
NCTF 103	NCS translation failure
NINT 99	Changed number intercept
NVIP 165	Not very important person status
ORAC 42	Originating revertive action for two-party lines with coded ringing
ORAF 40	Originating revertive action for two-party lines with frequency ringing
ORMC 36	Originating revertive action for multiparty lines with coded ringing
ORMF 43	Originating revertive action for multiparty lines with frequency ringing
OTAE	over the air activation service provisioning (OTASP) error
PNUN 142	Private network unavailable
PRSC 57	Priority screen fail
RFCD	Remote feature control denied



**TMTCNTL.TREAT** (continued)**TRMTFR, TRMTFR2, and TRMTFR3—feature-related treatments (Sheet 3 of 3)**

<b>Treatment mnemonic and number</b>	<b>Treatment description</b>
RFCE	Remote feature control error
RFCS	Remote feature control success
RMIA	Remote message indicator activation
RMID	Remote message indicator deactivation
RRPA 39	Revertive ring prefix announcement
RTEE 217-255	ISUP Hop Counter value expired
SCA 157	Selective call acceptance
SCRJ 150	Selective call rejection
SINT 125	Service interception
SORE 136	Station origination restriction error
SRRR 44	Single party revertive ringing
TBSY 179	Toll busy
TRGB	Trigger block
TRRF 41	Terminating revertive action for frequency ringing
UNPM	Unprogrammed mobile
WUCR 189	Wake-up call reminder (WUCR) treatment

**TRMTRS—resource shortage treatments**

These resource shortage treatments (listed in the table that follows) handle failures that occur due to software or hardware resource shortages, indicating

**TMTCNTL.TREAT** (continued)

inadequate capacity to handle the present load. They do not include treatments used to handle switching equipment malfunction.

**TRMTRS—resource shortage treatments**

<b>Treatment mnemonic and number</b>	<b>Treatment description</b>
CGRO 94	Customer group resource overflow
CHNF 160	Channel negotiation failure
CQOV 15	Centralized automatic message accounting (CAMA) queue overflow
EMR1 11	Emergency treatment 1
EMR2 12	Emergency treatment 2
EMR3 48	Emergency treatment 3
EMR4 49	Emergency treatment 4
EMR5 73	Emergency treatment 5
EMR6 74	Emergency treatment 6
FECG 35	Far-end congestion
GNCT 58	Generalized no-circuit
NBLH 9	Network blockage heavy traffic
NBLN 10	Network blockage normal traffic
NCRT 24	No circuit
NECG 34	Near-end congestion
NOSC 1	No service circuit
NOSR 93	No software resource
OTAR	OTASP resources unavailable
SORD 52	Storage overflow reorder
TOVD 37	Toll overload

**TMTCNTL.TREAT** (continued)**TRMTPR—protocol-related treatments**

These protocol-related treatments (listed in the table that follows) handle failures due to protocol translation or negotiation failure. They do not include treatments used to handle switching equipment malfunction.

**TRMTPR—protocol-related treatments**

<b>Treatment mnemonic and number</b>	<b>Treatment description</b>
NOBC 181	No bearer capability (BC) available
NORA 182	No routing available
PER1 183	Protocol error 1
PER2 184	Protocol error 2
PER3 185	Protocol error 3
PER4 186	Protocol error 4
PER5 187	Protocol error 5
CER1 188	Closed User Group (CUG) error 1

**Treatment subtables**

Treatment tables consist of control table TMTCNTL and treatments subtables TREAT at positions in the following list.

- OFFTREAT
- ITTRKGRP
- LNT
- TITRKGRP
- PXTRKGRP
- TOPS
- INT101TT
- PRIVLNTT
- FEATANNS

Each position is described in the following text:

---

**TMTCNTL.TREAT** (continued)

---

**Office Treatments Subtable**

EXTTMTNM = OFFTREAT

**Local/Toll, Gateway, Tandem**

Subtable OFFTREAT lists every treatment and provides a common set of treatments for incoming trunks. Treatments not applicable to incoming trunks must be routed to overflow or similar tone.

Treatments in subtable OFFTREAT must never contain code for receiver off-hook (ROH) in the route list and the route list must never terminate with codes for lockout (LKOUT) or idle (IDLE).

*Note:* See treatment GNCT on how to avoid a potential looping situation.

**Intertoll Treatments Subtable**

EXTTMTNM = ITTRKGRP

**Local/Toll**

Subtable ITTRKGRP is optional and is used in toll or combined local/toll switches to list treatments for incoming and two-way intertoll trunk groups (type IT), that differ from treatments in subtable OFFTREAT.

Treatments in subtable ITTRKGRP must never contain code for receiver off-hook (ROH) in the route list, and must never terminate with codes for lockout (LKOUT) or idle (IDLE).

*Note:* See treatment GNCT on how to avoid a potential looping situation.

**Incoming CAMA Treatments Subtable**

EXTTMTNM = INTRKGRP

**Local/Toll**

Subtable INTRKGRP is optional and used in toll or combined local-toll switches to list treatments for incoming or two-way CAMA/AMR5 trunk groups and trunk group type SC that differ from treatments in subtable OFFTREAT.

Treatments in subtable INTRKGRP must never contain code for receiver off-hook (ROH) in the route list, and the route list must never terminate with codes for lockout (LKOUT) or idle (IDLE).

*Note:* See treatment GNCT on how to avoid a potential looping situation.

## TMTCNTL.TREAT (continued)

---

### Line Treatments Subtable

EXTTMTNM = LNT

#### Local/Toll

Subtable LNT is used in all local and combined local/toll switches to specify routing for treatments associated with lines. Subtable LNT lists every treatment, and treatments that are not applicable to lines are routed to overflow or similar tone.

If the route list contains a treatment other than tone or announcement and an all-trunks-busy state occurs, then the calling line is automatically routed to reorder (RODR) treatment. If RODR is not required, the last two routes in the route list must be tone or announcement followed by lockout (LKOUT) or idle (IDLE).

All treatments routing to announcement or tone other than T60 or T120 in the route list must terminate with the code for lockout (LKOUT).

IDLE is a valid state, but use of IDLE extends disconnect time and causes originating OMs to increment twice per call.

All treatments without tones or announcements in the route list must not end in lockout (LKOUT) or idle (IDLE).

Lockout (LKOUT) or idle (IDLE) must not appear as the first element in the route list. They must always be preceded by tone or announcement.

### Local Incoming Trunk Treatments Subtable

EXTTMTNM = TITRKGRP

#### Local/Toll

Subtable TITRKGRP is optional and can be used in a combined local/toll switch to list treatments for incoming and two-way local trunk groups that differ from treatments in subtable OFFTREAT.

Subtable TITRKGRP must never contain code for receiver off-hook (ROH) in the route list, and the route list must never terminate with codes for lockout (LKOUT) or idle (IDLE).

*Note:* See treatment GNCT on how to avoid a potential looping situation.

### PBX Two-way Trunk Treatments Subtable

EXTTMTNM = PXTRKGRP

---

**TMTCNTL.TREAT** (continued)

---

**Local/Toll**

Subtable PXTRKGRP is optional and can be used in local or combined local/toll switches to list treatments for two-way PBX DID/DOD trunk groups, and trunk group types PX and P2, that differ from treatments in table OFFTREAT.

Treatments in subtable PXTRKGRP must never contain code for receiver off-hook (ROH) in the route list, and must never terminate with codes for lockout (LKOUT) or idle (IDLE).

*Note:* See treatment GNCT on how to avoid a potential looping situation.

**TOPS Treatments Subtable**

EXTTMTNM = TOPS

**Local/Toll with TOPS**

Subtable TOPS is optional and can be used in toll or combined local/toll switches with TOPS to list treatments for TOPS trunk groups and trunk group type TOPS that differ from treatments in subtable OFFTREAT.

Treatments in subtable TOPS must never contain code for receiver off-hook (ROH) in the route list, and must never terminate with codes for lockout (LKOUT) or idle (IDLE).

*Note:* See treatment GNCT on how to avoid a potential looping situation.

**DMS-300 International 101 Test Trunk Treatments Subtable**

EXTTMTNM = INT101TT

**Gateway**

Subtable INT101TT is optional and can be used to list treatments for international 101 test trunk groups that differ from treatments in subtable OFFTREAT.

**DMS-300 Private Line Trunk Treatments Subtable**

EXTTMTNM = PRIVLNTT

**Gateway**

Subtable PRIVLNTT is optional and can be used to list treatments for private line trunk groups that differ from treatments in subtable OFFTREAT.

**Routing options for each treatment**

If the DMS software encounters a treatment code, it accesses the TMTCNTL.TREAT table that applies to the originator of the call to determine

## TMTCNTL.TREAT (continued)

---

the operating company-defined tone or announcement that the originator hears.

Each tone or announcement is identified by a CLLI code in table CLLI.

The operating company specifies a single-treatment CLLI or a succession of treatment CLLIs as follows:

- When routed to a single-treatment CLLI
  - FSTRTSEL = S
  - Field name = CLLI
- When routed through a route table through a succession of CLLIs
  - FSTRTSEL = T
  - Field name = TABID, KEY

The treatment route list is specified in the applicable tables as follows:

- Local/Toll = office route table OFRT
- Gateway = overseas route tables OVR0 to OVR9

*Note:* If these route tables are accessed as a result of a treatment, each treatment CLLI is connected to the originator or call in the same order listed for a length of time prescribed for each treatment CLLI.

If the route table is accessed normally, that is, not as a result of a treatment, it is a list of alternates. The first free trunk found in the list of alternates is the only trunk connected.

### Treatment CLLIs

Each treatment CLLI must be defined in table CLLI and (except for fixed treatment CLLIs: IDLE, LKOUT, and COPP) in one of the following tables:

- TONES (software-generated tones)
- STN (hardware-generated tones)
- ANNS (recorded announcements)
- DRAMS (digital recorded announcements)

Fixed treatment CLLIs IDLE, LKOUT, and COPP are defined by the DMS software as follows:

---

**TMTCNTL.TREAT** (continued)

---

**IDLE**

Equivalent to originating line going off-hook, this must be the last treatment CLLI in route list. It is used in North America only.

**LKOUT**

Originating line is locked out; that is, connected to nothing for as long as it stays off-hook. It must be the last treatment CLLI in the route list.

**COPP**

Cutoff on permanent signal and partial dial that is associated with line treatments PSIG and PDIL to supply (on every standard line in the DMS-100 office) an open-battery signal as the first operation in processing permanent signal and partial dial subscriber line conditions. This routing list element has no impact on business sets, data units, or display phones.

The open-battery signal informs subscriber line equipment (suitably equipped), that the line has entered a permanent signal or partial dial state.

COPP cannot be used in other line treatments. If used for PSIG and PDIL line treatments, COPP must be first, and LKOUT must follow in the routing list.

*Note:* See treatment GNCT on how to avoid a potential looping situation.

**Description of treatment codes****AARD**

ANI account recently disallowed

**ACPR**

Authcode prompt (140)

**Tandem**

This treatment is used in international DMS-250 switches with the Credit Card Calling feature (with or without remote database). Route it to the announcement requesting a four-digit authorization code.

**Local/Toll, Gateway**

This treatment is redundant; set it to overflow or to a similar tone.

**ACRJ**

Anonymous caller rejection (166)

**Local/Toll, IBN**

Anonymous call is detected on a line with announcement type ANN.



## **TMTCNTL.TREAT** (continued)

---

### **ADBF**

ANI not found in the database (85)

#### **Tandem**

Call processing cannot find subscriber's automatic number identification (ANI) in database.

#### **Local/Toll, Gateway**

This treatment is redundant; set it to overflow or to a similar tone.

### **ADPA**

Address digits prompt announcement (142)

#### **Tandem**

This treatment is used in international DMS-250 switches with the Credit Card Calling feature (with or without remote database). Route it to an announcement prompting subscriber to enter destination digits.

#### **Local/Toll, Gateway**

This treatment is redundant; set it to overflow or to a similar tone.

### **AIFL**

Autoidentified outward dialing failure (87)

#### **Local, Local/Toll**

This treatment occurs on a call incoming on either a private branch exchange (PBX) line with the AIOD feature, or under the following conditions: on trunk group type PX or P2 with AIOD feature, field AIOD set to Y (yes). If the DMS switch fails to receive an AIOD message over the AIOD datalink within the specified delay and the operating company sets table AIODGRP field FAILDEF to TREATMENT then the call is sent to treatment.

Route it to the appropriate announcement or to an operator.

#### **Toll, Gateway, Tandem**

This treatment is redundant; set it to overflow or similar tone.

### **AIND**

Advanced Intelligent Network Disconnect

#### **Local, Local/Toll**

This treatment is applied when a call is disconnected due to the request from the SCP/Adjunct.

---

**TMTCNTL.TREAT** (continued)

---

**AINF**

Advanced Intelligent Network Final

**Local, Local/Toll**

This treatment is applied when there is a fatal call-related error.

**ANBB**

ANI Feature Group B blockage (107)

**Tandem**

Calls from other common carrier services subscriber (DCCS) attempts to access Feature Group B trunks, but originating ANI is not valid and is blocked in table ANISCRNU.

**Local/Toll, Gateway**

This treatment is redundant; set it to overflow or to a similar tone.

**ANCT**

Machine intercept (31)

**Local, Local/Toll**

Disconnected or out-of-service DNs are routed to announcement (machine intercept).

For information on assigning lines to this treatment, see OUT orders in the *SERVORD Reference Manual*.

**Toll, Gateway, Tandem: with E800 Service**

Disconnected DNs are routed to announcement.

**Toll, Gateway, Tandem: without E800 Service**

This treatment is redundant; set it to overflow or to a similar tone.

**ANFL**

Announcement fail (116)

**Local/Toll, Tandem, Gateway**

This treatment is redundant; set it to overflow or to a similar tone.

**ANIA**

ANI account status not allowed (76)

**Tandem, Gateway**

ANI is not found in database or ANI is found and set to block.

## TMTCNTL.TREAT (continued)

---

### **Local/Toll**

This treatment is redundant; set it to overflow or to a similar tone.

### **Local/Toll, Gateway, Tandem**

This treatment is redundant; set it to overflow or to a similar tone.

## **ANTO**

Answer time out (66)

### **Local/Toll, Gateway, Tandem**

This treatment is redundant; set it to overflow or to a similar tone.

## **ATBS**

Attendant busy (59)

### **ISDN**

Normal unspecified (31).

### **Local/Toll, Gateway, Tandem**

This treatment is redundant; set it to overflow or to a similar tone. IBN treatments are handled in table AUDIO.

## **ATDT**

ATD time out (106)

### **Tandem**

Office parameter ATD\_TIMEOUT\_OPTION in table OFCVAR is set to Y (yes), and calling subscriber does not disconnect (remains off-hook) long enough for audio tone detector (ATD) default timer to time out.

### **Local/Toll, Gateway**

This treatment is redundant; set it to overflow or to a similar tone.

## **ATHF**

Authentication failure

This treatment is used if an authentication failure occurs when setting up a mobile call.

## **BBFS**

Blue box fraud scanning (132)

### **Tandem**

Incoming trunk circuits are scanned for blue box fraud.

---

**TMTCNTL.TREAT** (continued)

---

**Local/Toll, Gateway**

This treatment is redundant; set it to overflow or to a similar tone.

**BCNI**

Bearer capability not implemented (161)

**ISDN**

Calling party attempts to establish a circuit-switched call, but the called party does not support circuit-switched bearer capabilities.

The progress message contains cause 65:

Bearer capability not implemented

and progress indicator 8:

In-band information or appropriate pattern not available

**Local/Toll, Gateway, Tandem**

This treatment is redundant; set it to overflow or to a similar tone.

**BLDN**

Blank directory number (18)

**Local, Local/Toll**

This is for the routing of unassigned directory numbers.

The thousand directory numbers, for each thousand group in table TOFCNAME with selector C, are automatically routed to this treatment upon initialization.

**ISDN**

The called directory number is unassigned.

The progress message contains cause 1:

Unallocated number

and progress indicator 8:

Inband information or appropriate pattern not available

**Toll, Gateway, Tandem**

This treatment is redundant; set it to overflow or to a similar tone.

## TMTCNTL.TREAT (continued)

---

### **BLMO**

Black listed mobile.

#### **Local**

BLMO treatment is set when a blacklisted mobile originates or receives a call. Network operators blacklist a mobile when it has been stolen. A blacklisted mobile can only make an emergency call

### **ISDN**

The called directory number is unassigned.

The progress message contains cause 1:

Unallocated number

and progress indicator 8:

Inband information or appropriate pattern not available

### **BUSY**

Busy line (19)

#### **Local/Toll**

A line is busy when one of the following conditions exists:

- The line without intercom (INT) option is assigned in table LENLINES with called and calling DN the same.
- A line or trunk dials a busy DN and call waiting is not in effect.
- A called line is seized for testing or is out of service, and is not assigned the plug-up option.

Test equipment (for example, test desk, cabinet, CALRS, or incoming operator verifications trunks) can access busy lines, except if the busy line has the no-double-connection (NDC) option assigned in table LENLINES or in table IBNLINES.

#### **ISDN**

The called directory number is busy

The progress message contains cause 17:

User busy

---

**TMTCNTL.TREAT** (continued)

---

**Gateway**

Call incoming on a private line, R1 signaling trunk, or international 101 test line. Call outgoing on a CCS6 signaling trunk.

During call connection, terminating exchange determines whether the called party line is busy, faulty, or out of service.

**B900**

Blocked 899 calls

**Local/Toll, Toll, Tandem, Gateway**

This treatment blocks a call associated with a 900 number that has been detected as fraudulent call by the 900FP (900 Fraud Prevention) feature.

**CACB**

Carrier access code blocked (124)

**Local/Toll (end office with Equal Access feature)**

Dialed carrier access code (CAC) is blocked because the carrier does not handle CAC calls, or because the carrier handles traffic from subscribers where it is the primary inter-LATA carrier.

**Local/Toll (without Equal Access feature), Gateway, Tandem**

This treatment is redundant; set it to overflow or to a similar tone.

**CACE**

Carrier access code in error (79)

**Local/Toll (end office with Equal Access feature)**

Dialed carrier access code 10xxx is vacant or changed.

Route to announcement.

**ISDN**

There is no route to the specified transit network.

Progress message contains cause 2:

No route to specified transit network

**Local/Toll (without Equal Access feature), Gateway, Tandem**

This treatment is redundant; set it to overflow or to a similar tone.

**CBDN**

Call back destination number (145)

## **TMTCNTL.TREAT** (continued)

---

### **Tandem**

This treatment is used in an international DMS-250 switch with the Call Back International Subscriber Dialed (ISD) feature. Route to the announcement requesting the subscriber to enter the destination number. The first digit entered stops the announcement.

### **Local/Toll, Gateway**

This treatment is redundant; set it to overflow or to a similar tone.

## **CBFC**

CASOP Blocked Final Carrier

### **Local/Toll**

This treatment is used when an automatic recall (AR) call is blocked in the second screening stage. The second screening stage occurs during the routing of the call.

## **CBTN**

Clearback tone (114)

### **Local/Toll, Tandem, Gateway**

This treatment is redundant; set it to overflow or to a similar tone.

## **CCAP**

Credit card announcement prompt (139)

### **Tandem**

This treatment is used in an international DMS-250 switch Credit Card Calling feature (with or without remote database). Route to the announcement prompting subscriber to enter a 10-digit credit card number.

### **Local/Toll, Gateway**

This treatment is redundant; set it to overflow or to a similar tone.

## **CCCF**

Carrier call completion failure (149)

### **TOPS**

This treatment is used in a TOPS office with the Alternate Carrier Selection feature. It is for calls on incoming TOPS trunks with carrier call completion failure.

### **Local/Toll, Gateway, Tandem**

This treatment is redundant; set it to overflow or to a similar tone.

---

**TMTCNTL.TREAT** (continued)

---

**CCDT**

Credit card dialtone (143)

**Tandem**

This treatment is used in an international DMS-250 switch with the Credit Card Calling feature (with or without remote database). Route to the prompt tone that is used with the second dial tone option.

**Local/Toll, Gateway**

This treatment is redundant; set it to overflow or to a similar tone.

**CCIR**

Credit card invalid release (141)

**Tandem**

This treatment is used in an international DMS-250 switch with the Credit Card Calling feature (with or without remote database). Route to the announcement that informs the subscriber that the credit card number is invalid (more than allowed number of code digits). The call is disconnected.

**Local/Toll, Gateway**

This treatment is redundant; set it to overflow or to a similar tone.

**CCNA**

Calling card not allowed (91)

**Tandem**

This treatment is used in an international DMS-250 switch with the Credit Card Calling feature (with or without remote database) if a credit card number is marked as ABUSED in table CCTAB. The call is disconnected.

**Local/Toll, Gateway**

This treatment is redundant; set it to overflow or to a similar tone.

**CCNV**

Calling card invalid (90)

**Tandem**

This treatment is used in a DMS-250 switch with the Mechanized Calling Card Service (MCCS) feature if the Travel Card Number (TCN) is invalid.

The subscriber has one more chance to enter a valid TCN. Route to the announcement: "Please dial a valid calling card number."



## **TMTCNTL.TREAT** (continued)

---

This treatment is used in an international DMS-250 switch with the Credit Card Calling feature (with or without remote database), if the credit card authorization code does not match the authorization code filed against the credit card number.

### **Local/Toll, Gateway**

This treatment is redundant; set it to overflow or to a similar tone.

### **CCRG**

Cumulative Charge Restriction for General Subscribers

This treatment is used to indicate that a general subscriber call has failed screening due to Cumulative Charge Restriction. The call is then routed to this treatment, which defaults to Call Not Allowed (CNAD).

### **CCRH**

Cumulative Charge Restriction for PHS (Personal) Subscribers

This treatment is used to indicate that a PHS subscriber call has failed screening due to Cumulative Charge Restriction. The call is then routed to this treatment, which defaults to Call Not Allowed (CNAD).

### **CCRM**

Cumulative Charge Restriction for Mobile Subscribers

This treatment is used to indicate that a mobile subscriber call has failed screening due to Cumulative Charge Restriction. The call is then routed to this treatment, which defaults to Call Not Allowed (CNAD).

### **CCRP**

Cumulative Charge Restriction for Payphone Subscribers

This treatment is used to indicate that a payphone subscriber call has failed screening due to Cumulative Charge Restriction. The call is then routed to this treatment, which defaults to Call Not Allowed (CNAD).

### **CCRT**

Cumulative Charge Restriction for Third Party Billed Calls

This treatment is used to indicate that a third party billed call has failed screening due to Cumulative Charge Restriction. The call is then routed to this treatment, which defaults to Call Not Allowed (CNAD).

---

**TMTCNTL.TREAT** (continued)

---

**CCTO**

Calling card time out (89)

**Tandem**

This treatment is used if the subscriber fails to enter a Travel Card Number (TCN) digit within 10 s (controlled by office parameter MCCS\_CALLING\_CARD\_TIMEOUT in table OFCVAR).

Route it to an announcement.

If digits are not dialed after the announcement, the call is routed to partial dial time-out treatment (PDIL).

**Local/Toll, Gateway**

This treatment is redundant; set it to overflow or to a similar tone.

**CER1**

CUG error 1 (188)

**Gateway**

This treatment is used if the information in the initial address message with additional information (IAI) is incorrect.

**Local, Toll**

This treatment is redundant; set it to overflow or to a similar tone.

**CFOV**

Call forwarding overflow (121)

**Local/Toll**

The call cannot be forwarded through the POTS Call Forwarding base station because the maximum simultaneous forwarding limit has been reached for the base station.

**Tandem, Gateway**

This treatment is redundant; set it to overflow or to a similar tone.

**CFWV**

Variable call forwarding verification (77)

**Local, Local/Toll (end office with Variable Call Forwarding feature)**

A subscriber with Variable Call Forwarding is routed to CFWV if the call forwarding activation service access code is dialed and if call forwarding is already active on the line.

## **TMTCNTL.TREAT** (continued)

---

### **Local/Toll (without Variable Call Forwarding feature) Gateway, Tandem**

This treatment is redundant; set it to overflow or to a similar tone.

### **CGFL**

ISDN closed user group call failed (154)

### **Gateway**

This treatment is used if there is an unauthorized attempt to use an ISDN closed user group (CUG) service. The DMS-300 Service Screening by Destination on Issue feature must be present in the office.

### **Local/Toll, Tandem**

This treatment is redundant; set it to overflow or to a similar tone.

### **CGRO**

Customer group resource overflow (94)

### **Local/Toll**

An IBN call is routed if shortages occur on resources provisioned on a customer group basis. Resources include

- the number of six-port conference circuits datafilled against the customer group
- the number of parking queues datafilled against the customer group

### **Gateway, Tandem**

This treatment is redundant; set it to overflow or to a similar tone.

### **CHAF**

Changed 800 number forward (118)

### **Originating Screening Office With Enhanced 800 Service**

This treatment is used if the 800+ response from the operating company (Bell Canada) database is as follows:

- changed 800 number-treatment 2
- route to national directory assistance

### **Local/Toll, Tandem, Gateway**

This treatment is redundant; set it to overflow or to a similar tone.

### **CHAN**

Changed 800 number announcement (117)

---

**TMTCNTL.TREAT** (continued)

---

**Originating Screening Office With Enhanced 800 Service**

This treatment is used if the 800+ response from the operating company (Bell Canada) database is as follows:

- changed 800 number-treatment 1
- route to the announcement that informs the subscriber that the dialed 800 number has changed and the number must be checked before redialing

**Local/Toll, Tandem, Gateway**

This treatment is redundant; set it to overflow or to a similar tone.

**CHNF**

Channel negotiation failure (160)

**ISDN**

This treatment is used if the B-channel negotiation fails at the terminating end.

The progress message contains cause 41:

Temporary failure

and progress indicator 8:

In-band information or appropriate pattern not available

**Local/Toll, Tandem, Gateway**

This treatment is redundant; set it to overflow or to a similar tone.

**CMGA**

Call Management Group activation (224)

The CMG line receives this treatment when the end user activates simultaneous ringing status on the line.

**CMGD**

Call Management Group deactivation (225)

The CMG line receives this treatment when the end user deactivates simultaneous ringing status on the line.

**CNAC**

Call not accepted (113)

## **TMTCNTL.TREAT** (continued)

---

### **IBN with Open Number Translations feature**

Table IBNXLA selector NET DOD is datafilled, and table LINEATTR field XLASYS is not NIL or PX. A DFIL log is generated.

### **Tandem**

This treatment is used in an international DMS-250 switch with the Call Back International Subscriber Dialed (ISD) feature if the calling line ID (CLID) is not eight or nine digits in length; the call is disconnected if applied.

### **ISDN**

The bearer capability of the call originator is not compatible with the call terminator. Bearer capability is defined in table BCDEF, and assigned to ISDN terminals, data units, and electronic business sets in table KSETFEAT.

Progress message contains cause 88:

Incomplete destination

### **Local/Toll, Gateway**

This treatment is redundant; set it to overflow or similar tone.

## **CNAD**

Call not allowed (137)

### **Tandem**

This treatment is used in an international DMS-250 switch with the Call Back International Subscriber Dialed (ISD) feature. The calling line ID (CLID) has the correct number of digits, but is invalid (listed as either delinquent or refused service), or called party address digits fail digit translation screening on third-party billed call.

Call is disconnected.

### **Local/Toll PVN SSP**

In a switch equipped with the Private Virtual Network (PVN) feature and a service switching point (SSP), this treatment occurs if the database returns call not allowed.

### **Local/Toll not PVN SSP, Gateway**

This treatment is redundant; set it to overflow or to a similar tone.

## **CNDT**

Coin denied termination (5)

---

**TMTCNTL.TREAT** (continued)

---

**Local, Local/Toll, Tandem**

The dialed coin line directory number terminates in a switch with the denied terminating (DTM) option.

*Note:* Calls to a non-coin line with option DTM result in treatment DNTR.

**Toll, Gateway**

This treatment is redundant; set it to overflow or to a similar tone.

**CNOT**

Coin overtime (55)

**Local, Local/Toll**

This treatment is used if the switch has the Local Coin Overtime feature, and the coin line is terminated if coins are not deposited for an overtime period.

If the switch does not have the Local Coin Overtime feature, route to overflow or to a similar tone.

**Toll, Gateway, Tandem**

This treatment is redundant; set it to overflow or to a similar tone.

**CONF**

Confirm tone (38)

**Local, Local/Toll**

This treatment is used if the activation code is dialed on a line with Call Forwarding or Speed Calling features.

If dial tone is required following a confirmation tone, route list elements consist of a confirmation tone and IDLE. Otherwise, route list elements consist of a confirmation tone, no tone, and lockout.

**ISDN**

Normal unspecified (31).

**Toll, Gateway, Tandem**

This treatment is redundant; set it to overflow or to a similar tone.

**CONP**

Connection not possible (98)

## **TMTCNTL.TREAT** (continued)

---

### **Tandem**

This treatment is used if the call cannot be completed by carriers because of 3L-to-3L blocking (transmission quality requirements).

### **ISDN**

Channel type not implemented.

Progress message contains cause 66:

Channel type not implemented

### **Local/Toll, Gateway**

This treatment is redundant; set it to overflow or to a similar tone.

## **COSX**

Class of service exceeded (123)

### **Tandem**

Translation encounters an invalid Class of Service (COS).

### **Local/Toll, Gateway**

This treatment is redundant; set it to overflow or to a similar tone.

## **CQOV**

CAMA queue overflow (15)

### **Local/Toll with TOPS**

This treatment can be used for switches that are equipped with TOPS; the call is routed if the queue overflows.

### **Local/Toll with no TOPS, Gateway, Tandem**

This treatment is redundant; set it to overflow or to a similar tone.

## **CREJ**

Call rejected (134)

### **ISDN**

Functional terminal rejects call before it is answered.

The originating subscriber receives an audible ringback. To minimize the impact on the originating subscriber, the ringback generated by the tone set in table TONES with pseudo CLLI code \*RING is continued before applying the busy tone, followed by lockout.

---

**TMTCNTL.TREAT** (continued)

---

The progress message contains cause 21:

Call rejected

**Local/Toll, Gateway, Tandem**

This treatment is redundant; set it to overflow or to a similar tone.

**CRTC**

Call redirect confirmation treatment

The Call Redirect feature controller (originator) receives this treatment after a successful translation of the routing DN.

**C7AP**

CCS7 application failure treatment (130)

**Local/Toll AT or EAEO**

This treatment is used in an access tandem (AT) or equal access end office (EAEO) switch in service switching point (SSP) calls (for example, E800, 800+, and PVN) with CCS7 application failures, such as:

- service control point (SCP) database time out or trouble
- transaction capabilities application part (TCAP) message decoding problems
- no transaction identification available for service switching point (SSP) calls

The RODR treatment has been replaced by treatment C7AP. The RODR treatment is dedicated to distorted signals during dialing or impulsing.

**Local/Toll other than AT or EAEO, Gateway, Tandem**

This treatment is redundant; set it to overflow or to a similar tone.

**DACD**

Dial carrier access code (84)

**Local/Toll (end office with Equal Access feature)**

10xxx must be dialed.

Route call to announcement.

**Local/Toll (without Equal Access feature), Gateway, Tandem**

This treatment is redundant; set it to overflow or to a similar tone.



## TMTCNTL.TREAT (continued)

---

### DCFC

Disallowed coin free call (56)

#### **Local, Local/Toll**

This treatment is used for a coinfree line or line class code CFD in table LINEATTR, when other than operator assisted (0+) call or three-digit service codes are dialed.

#### **Toll, Gateway, Tandem**

This treatment is redundant; set it to overflow or to a similar tone.

### DISC

Disconnect timing (45)

#### **Local, Local/Toll**

This treatment is used if the subscriber fails to go on-hook within 10 s after the other party terminates a call.

The call is forcibly disconnected from a CAMA position served by a non TOPS switch.

An answer has not been received on a direct dial overseas DDO call within 5 min after call setup.

Origination (due to hardware failure) is used from an outgoing emergency service bureau (E911) trunk.

#### **Toll, Gateway, Tandem**

This treatment is redundant; set it to overflow or to a similar tone.

### DNTR

Denied terminating (33)

#### **Local, Local/Toll**

This treatment is used when a noncoin line directory number is dialed, terminating with the denied terminating (DTM) option. This treatment is also used if the DN of an ACD INCALLS key is called directly.

*Note:* Calls to coin lines with option DTM result in treatment CNDDT.

#### **ISDN**

Incoming calls are barred.

---

**TMTCNTL.TREAT** (continued)

---

The progress message contains cause 54:

Incoming calls barred

**Toll, Gateway, Tandem**

This treatment is redundant; set it to overflow or to a similar tone.

**DODT**

Denied originating data terminal (61)

**Local/Toll, Gateway**

This treatment is used if a data unit is attempting to originate a connect sequence without the RS-232 DTR signal present.

**Tandem**

This treatment is redundant; set it to overflow or to a similar tone.

**DSCN**

Call waiting ID disconnect option (176)

**Local/Toll, Local**

This treatment is used if a subscriber has the Spontaneous Call Waiting Identification with Disposition (DSCWID) feature and the subscriber chooses the announcement-before-disconnect (DISCON) option, which gives the calling party an announcement before disconnecting the call.

**Tandem, Toll, Gateway**

This treatment is redundant; set it to overflow or to a similar tone.

**DTFL**

Datafill error (131)

**Tandem**

This treatment is used if a datafill error is encountered in offices with service access code network management (SACNWM) and code controls feature. If calls do not successfully complete, INWATXLA and NCS translations attempt to index table HNPACONT using the same STS used for SACNWM. The call initiates a continuous loop if allowed to continue.

**Tandem**

A datafill error is encountered.

**Local/Toll, Gateway**

This treatment is redundant; set it to overflow or to a similar tone.

## TMTCNTL.TREAT (continued)

---

### D950

Dial 950 (80)

#### **Local/Toll (end office with Equal Access feature)**

10xxx is dialed instead of 950-1xxx. Table OCCINFO field ACCESS is set to INTERIM.

Route the call to an announcement.

#### **Local/Toll (without Equal Access feature), Gateway, Tandem**

This treatment is redundant; set it to overflow or to a similar tone.

### EMR1

Emergency treatment 1 (11)

#### **Local/Toll, Tandem**

This treatment is used if a call is deflected by network management code blocking, destination code cancellation, or alternate route control, or if the subscriber set deflected calls to route EA1.

#### **Gateway**

This treatment is redundant; set it to overflow or to a similar tone.

### EMR2

Emergency treatment 2 (12)

#### **Local/Toll, Tandem**

This treatment is used if a call is deflected by network management code blocking, destination code cancellation, or alternate route control, or where the subscriber set deflected calls to route EA2.

#### **Gateway**

This treatment is redundant; set it to overflow or to a similar tone.

### EMR3

Emergency treatment 3 (48)

#### **Local/Toll with TOPS**

This treatment is used if the digits dialed are other than 0- and the deflect call threshold for queue is exceeded. (See table TQCQINFO fields CWON and CWOFF for enabling calls waiting. Also see table QMSCQDEF for information on queue length threshold tables.)

---

**TMTCNTL.TREAT** (continued)

---

**Gateway, Tandem**

This treatment is redundant; set it to overflow or to a similar tone.

**EMR4**

Emergency treatment 4 (49)

**Local/Toll with TOPS**

This treatment is used if the digits dialed are 0- and if the deflect call threshold for queue is exceeded. (See the description of table QTTIDX for information on queue length threshold tables.)

**Local/Toll (without TOPS), Gateway, Tandem**

This treatment is redundant; set it to overflow or to a similar tone.

**EMR5**

Emergency treatment 5 (73)

**Local/Toll with TOPS MP DA**

This treatment is used in a TOPS switch equipped to connect directory assistance (DA) and intercept (INT) calls to TOPS multipurpose (MP) positions; excess calls in DA call waiting (CW) queue and DA call are not recalls.

**Local/Toll (without TOPS MP DA), Gateway, Tandem**

This treatment is redundant; set it to overflow or to a similar tone.

**EMR6**

Emergency treatment 6 (74)

**Local/Toll with TOPS MP DA**

This treatment is used in a TOPS switch equipped to connect DA and INT calls to TOPS MP positions; excess calls in the DA CW queue and INT calls are not recalls.

**Local/Toll (TOPS MP DA), Gateway, Tandem**

This treatment is redundant; set it to overflow or to a similar tone.

**ERDS**

Trunk permanent ground (70)

**Local/Toll, Gateway**

This treatment is used if a permanent ground is detected during a call; the call is disconnected and the cut-off relay is activated to save power.

## **TMTCNTL.TREAT** (continued)

---

### **Tandem**

This treatment is redundant; set it to overflow or to a similar tone.

### **EROR**

ERV originator

### **ERTO**

ERV timeout

### **ERTR**

ERV terminator

### **ESNF**

Customer unauthorized electronic serial number (ESN) fraud treatment

### **FACJ**

Facility Rejected

This treatment is used (set) by the Closed User Group service to indicate that an incoming ISUP call with "CUG Without Outgoing Access" must be released with a cause value of #29 (Facility Rejected). This treatment is applied when, for example, an incoming call with "CUG Without Outgoing Access" attempts to access an outgoing network/agent without CUG capability.

### **FDER**

Feature data error (92)

### **Local K&S (Austria)**

This treatment is used if an invalid call forward attempt is made; it is used by K&S (Austria) Call Forwarding features.

FDER cannot be used in North American switches.

### **Local/Toll, Gateway, Tandem**

This treatment is redundant; set it to overflow or to a similar tone.

### **FDNZ**

First digit not zero (88)

### **Tandem**

This treatment is used in a DMS-250 switch either with the Mechanized Calling Card Service (MCCS) feature on travel card number (TCN) call originations, or with the Call Back International Subscriber Dialed (ISD)

---

**TMTCNTL.TREAT** (continued)

---

feature, if the first digit of the address is not zero. The subscriber has one more chance to dial called number correctly. Route the call to an announcement.

**Local/Toll, Gateway**

This treatment is redundant; set it to overflow or to a similar tone.

**FECG**

Far end congestion (35)

**Local/Toll, Tandem**

The immediate cause of failure is the inability to get a path through the network over metallic access trunk due to far end congestion. This treatment is used if the far end encounters congestion on the network or outgoing trunks during call connection on the first attempt.

**Gateway**

This treatment is used on a call incoming on a private line, R1 signaling trunk or international 101 test line, or a call outgoing on CCITT#5 signaling (N5) if

- the far-end office encounters congestion on the network or outgoing trunks during call connection on the first attempt.
- the call incoming on a private line, R1 signaling trunk, or international 101 test line is outgoing on an N5 signaling trunk.

This treatment is used if the connected call fails on the first attempt because of the following:

- proceed to send message was not received
- proceed to send message was removed before seizure removed
- release guard was not received

This treatment is used on the second attempt, if the far-end office encounters congestion on the network or on outgoing trunks.

**FNAL**

Feature not allowed (68)

**Local/Toll**

This treatment is used if a caller attempts to use a feature that is not assigned to the line.

This treatment is distinct from NACK, which occurs if a caller attempts to use a custom calling feature and the request cannot be served.

## **TMTCNTL.TREAT** (continued)

---

For example, if subscriber dials \*73, the feature access code for call forwarding, but the subscriber line does not have the call forwarding feature, then the call is given FNAL treatment.

### **ISDN**

This treatment is used if the requested facility is not subscribed or the service or option is not implemented.

The progress message contains cause 50:

Requested facility not subscribed

### **Tandem**

This treatment is used in an international DMS-250 switch with the Call Back International Subscriber Dialed (ISD) feature. If the Calling Line ID (CLI) has the correct number of digits but indicates a mobile phone line or pay phone line, the call is disconnected.

### **Gateway**

This treatment is redundant; set it to overflow or to a similar tone.

## **FRDR**

Feature reorder (129)

### **Local/Toll with the IBN Message Service feature**

This treatment is used if Voice Message Exchange (VMX) failure is detected during the activation or deactivation of the message waiting indicator.

Treatment RODR has been replaced by treatment FRDR. Treatment RODR is dedicated for distorted signals during dialing or impulsing.

A T120 tone is required by VMX. VMX users datafill treatment FRDR the same as RODR. This treatment increments the feature-related operational measurements (OM) treatment group rather than the equipment-related OM treatment group.

If FRDR is not datafilled in table TMTCNTL.TREAT, the default treatment is RODR.

### **Local/Toll without the IBN Message Service feature Gateway, Tandem**

This treatment is redundant; set it to overflow or to a similar tone.

## **GFNV**

Global fiber optic network card (FONCARD) is not valid.

---

**TMTCNTL.TREAT** (continued)

---

**GNCT**

Generalized no circuit (58)

**Local/Toll**

This treatment is used if a trunk group is the last group in a route, and an all-trunks-busy condition is encountered.

Looping occurs if the last element in a route list for GNCT is busy and the treatment GNCT is selected again. To prevent looping, add tone T120 (never busy) as the last element in a route list.

Treatment GNCT is selected.

If the trunk group type is VR, the treatment NOSC (not GNCT) is selected and routed to a line or a trunk.

**Gateway**

This treatment is used if call processing detects a no-circuit condition, excluding receivers and verification trunks.

**Tandem**

This treatment is used if a call is originating on an incoming or two-way trunk, and all trunks that are associated with outgoing routes are busy.

**ISDN**

No circuit or channel is available.

The call cannot be completed from the calling interface due to unavailable equipment or facilities.

Progress message contains cause 34:

Circuit/channel congestion

and progress indicator 8:

In-band information or appropriate pattern not available

No channel is available at the calling interface because both B-channels are being used by other sets on the loop, or because the set attempting to originate has an active call and the set did not request an exclusive B-channel. The network sends the calling subscriber a release complete message cause 34:

Bearer capability not implemented



## **TMTCNTL.TREAT** (continued)

---

The network cannot allocate the channel that the calling subscriber indicated as exclusive in the originating setup message. The network sends the calling subscriber the release complete message cause 44:

Requested channel not available

### **HNPI**

Home NPA intercept (16)

#### **Local/Toll**

This treatment is used if home NPA digits are dialed and home NPA dialing is not permitted.

This treatment is assigned against the home numbering plan area (NPA) in table HNPACONT.HNPACODE with code type VCT.

#### **Gateway, Tandem**

This treatment is redundant; set it to overflow or to a similar tone.

### **ICCB**

Incoming Call Barred within Closed User Group (CUG)

This treatment is used (set) by the Closed User Group service to indicate that an incoming ISUP call must be released with a cause value of #55 (Incoming Call Barred within CUG). This treatment is applied when an incoming call terminates in a CUG with this treatment activated.

### **ICNF**

Invalid conference code (151)

#### **Tandem**

This treatment is used in an international DMS-250 switch with the Three-Way Calling feature. The operating company can datafill ICNF, but it has no effect on what the subscriber hears. DMS-250 three-way conference calling software allocates 5 s of REORDER tone.

The originator and controller of the three-way conference call dials an invalid or inappropriate conference feature code.

#### **Local/Toll, Gateway**

This treatment is redundant; set it to overflow or to a similar tone.

### **ICSA**

In call service activated

---

**TMTCNTL.TREAT** (continued)

---

**Local, Local/Toll**

A line that has entered the ICCTRL activation code (\*02) is routed here.

**ICSD**

In call service deactivated

**Local, Local/Toll**

A line that has entered the ICCTRL deactivation code (\*02) is routed here.

**IDPB**

International direct distance dialing prohibited (112)

**Local/Toll, Gateway**

This treatment is redundant; set it to overflow or to a similar tone.

**Tandem**

An international direct distance dialing (IDDD) call is originated by a subscriber whose AUTHCODE or Automatic Number Identification (ANI) database does not allow dialing IDDD destination numbers.

**IIEC**

Feature-related, invalid information element component

**ILRR**

International line restriction (122)

**Local, Local/Toll (international end office)**

This treatment is used in an international end office with the International Line Restrictions (ILR) feature, if an attempt is made to originate a call restricted by ILR for the originating line.

**Local/Toll (other than international end office), Gateway, Tandem**

This treatment is redundant; set it to overflow or to a similar tone.

**ILRS**

Inter-LATA restriction (82)

**Local, Local/Toll (end office with Equal Access feature)**

This treatment is used if an inter-LATA call is originated, and if the line option inter-LATA toll denied (ITD) is assigned.

The subscriber with the Carrier Toll Denied (CTD) feature attempts to place a toll call using a carrier and is denied access. The call is either completed or blocked, and sent to an inter-LATA restricted (ILRS) treatment.

**TMTCNTL.TREAT** (continued)

The decision to block a call to a carrier, defined as toll denied, depends on call characteristics, as described in the table that follows.

**Call type descriptions**

<b>Call type</b>	<b>Description</b>
(10xxx) 1 + 7/10D	Direct dial - ILRS treatment
(10xxx) 0 + 7/10D	Operator assisted - call let through
(10xxx) 011 + CC + NN	Direct dial - ILRS treatment
(10xxx) 01 + CC + NN	Operator assisted - call let through
10xxx + #	Direct dial - ILRS treatment
10xxx + 0	Direct dial - call let through
950<#0106>1xxx	Direct dial - ILRS treatment
1 + 800 + 4D	Direct dial - call let through
(10xxx) 1 + NPA + 555 + 4D	Direct dial - ILRS treatment
<b>Note:</b> The parentheses mean that the carrier digits are optional in the dialing sequence.	

Route the call to an announcement.

**Local/Toll (without Equal Access feature), Gateway, Tandem**

This treatment is redundant; set it to overflow or to a similar tone.

**INAC**

Invalid account code (4)

**Local/Toll, Gateway**

This treatment is redundant; set it to overflow or to a similar tone.

**Tandem**

Account code validation is required and the dialed account code is not valid for the trunk group.

**INAU**

Invalid authorization code (53)

**Local/Toll, Gateway**

This treatment is redundant; set it to overflow or to a similar tone.

---

**TMTCNTL.TREAT** (continued)

---

**Tandem**

This treatment is used if

- the AUTHCODE is invalid.
- the city code screening specifies call blocked because the AUTHCODE was not dialed in a valid city of origin.
- the dialed security code digits associated with the AUTHCODE do not match the security code digits stored against the AUTHCODE

**INBT**

Installation busy treatment (127)

**LOCAL (international NETAS)**

An incoming call attempts to terminate on a line in an installation busy (INB) state.

**Local/Toll, Gateway, Tandem**

This treatment is redundant; set it to overflow or to a similar tone.

**INCC**

Invalid city code (97)

**Tandem**

This treatment is used if an invalid city code is dialed.

**Local/Toll, Gateway**

This treatment is redundant; set it to overflow or to a similar tone.

**INOC**

Invalid operator code (75)

**Local/Toll, Gateway Tandem**

This treatment is redundant; set it to overflow or to a similar tone.

**INPD**

Invalid PIN digit (110)

**Local/Toll, Gateway**

This treatment is redundant; set it to overflow or to a similar tone.

**Tandem**

This treatment is used if the dialed personal identification number (PIN) digits do not match PIN digits in the AUTHCODE database.

## TMTCNTL.TREAT (continued)

---

### INVM

Invalid message (169)

#### **Local/Toll, IBN**

This treatment is used if an invalid numbering plan indicator is received in the called party number, or if an invalid calling category is received.

### ISAX

ISA exit

#### **Local, Local/Toll (end office with custom calling features)**

This treatment is used when a caller has successfully selected an option from a first level menu but has not selected any option from a second or subsequent level menu.

#### **ISDN**

The facility is rejected, or service or option is not allowed.

Progress message contains cause 29:

Facility rejected

Local/Toll (without custom calling features)

#### **Gateway, Tandem**

This treatment is redundant; set it to overflow or to a similar tone.

### ITCF

Information transfer capability request fail (164)

#### **Gateway**

This treatment is used if the information transfer capability (ITC) is not functional or an invalid calling category is received.

#### **Local, Toll**

This treatment is redundant; set it to overflow or to a similar tone.

### IVCC

Invalid corridor call (108)

#### **Local, Local/Toll (end office with Equal Access feature)**

This treatment is used if an invalid inter-LATA non-corridor call using OTC is made.

---

**TMTCNTL.TREAT** (continued)

---

**Local/Toll (without Equal Access feature), Gateway, Tandem**

This treatment is redundant; set it to overflow or to a similar tone.

**IWUC**

International wake-up call (126)

**Local, Local/Toll (international end office)**

This treatment is used in an international end office with the international Wake-up Call (IWUC) feature during the wake-up process. Route the call to the wake-up announcement.

**Tandem**

This treatment is used in an international DMS-250 with the call back ISD feature. Route to the announcement requesting subscriber disconnect (at the end of first stage). The announcement cannot be broken by dialing digits.

**Local/Toll (other than international end office), Gateway**

This treatment is redundant; set it to overflow or to a similar tone.

**JACK**

Justified alternate calling knowledge (163)

**Tandem**

This treatment is used if a hotel call fails line information (LIDB) verification twice. The treatment may route to an announcement tone or to a terminating trunk.

**Local/Toll, Gateway**

This treatment is redundant; set it to overflow or to a similar tone.

**LCAB**

Local call area barred (96)

**Tandem**

This treatment is used if a local call attempt is made over a carrier. Carriers are not authorized to complete calls that originate and terminate within the same local calling area.

**Local/Toll, Gateway**

This treatment is redundant; set it to overflow or to a similar tone.

**LBSY**

Local busy (178)

## **TMTCNTL.TREAT** (continued)

---

### **Local, Local/Toll**

This treatment is used if a busy condition is encountered during a local call attempt. The DMS switch determines if the call is a local call, then routes the call to this treatment if it is unable to complete the call.

### **Toll, Gateway**

This treatment is redundant; set it to overflow or to a similar tone.

## **LCNV**

LEC calling card not valid (153)

### **Tandem**

This treatment is used to prompt the subscriber to enter a valid local exchange carrier (LEC) calling card number, if the subscriber enters an invalid number the first time, or if the call times out due to a partial dial condition. The DMS-250 LEC Calling Card Validation (Bong Tone) feature must be present in the office.

Datafill in table TMTCNTL.TREAT for treatment LCNV has no effect on what a subscriber hears if this treatment is applied for LEC calling card calls. The LCNV entry must be datafilled in table MCCSANNs with an appropriate announcement CLLI recorded on a digital recorded announcement machine (DRAM).

### **Local/Toll, Gateway**

This treatment is redundant; set it to overflow or to a similar tone.

## **LDA A**

Long distance signal activated (211)

### **Local, Local/Toll**

A line that has entered the LDS activation code \*49 (or 1149) is routed here.

## **LDAD**

Long distance signal deactivated (212)

### **Local, Local/Toll**

A line that has entered the LDS deactivation code 1149 (or \*49) is routed here.

## **LECV**

LEC calling card valid (152)

---

**TMTCNTL.TREAT** (continued)

---

**Tandem**

This treatment informs the subscriber that the LEC calling card number validation was successful and that the call is progressing normally. The DMS-250 LEC Calling Card Validation (Bong Tone) feature must be present in the office.

Datafill in table TMTCNTL.TREAT for treatment LECV has no effect on what the subscriber hears if the treatment is applied for LEC calling card calls. The LECV entry must be datafilled in table MCCSANNNS with the appropriate announcement CLLI recorded on a DRAM.

*Note:* A new cause value, currently listed as CSE\_26 in table TMTMAP, is changed to MISRCALL.

**Local/Toll, Gateway**

This treatment is redundant; set it to overflow or to a similar tone.

**LNPM**

LNP Misrouted Call to a Ported Number

This treatment indicates that an LNP call to a ported number was misrouted. LNPM can be mapped to a DRAM announcement that indicates the call did not complete.

**MANL**

Manual line (26)

**Local, Local/Toll**

A line with originating manual service (option MAN assigned in table LENLINES) is routed to this treatment if it is originating a call.

**Toll, Gateway, Tandem**

This treatment is redundant; set it to overflow or to a similar tone.

**MHLD**

Music on hold (60)

**ISDN**

Normal unspecified (31)

**Local/Toll, Gateway, Tandem**

This treatment is redundant; set it to overflow or to a similar tone. IBN treatments are handled in table AUDIO.



## TMTCNTL.TREAT (continued)

---

### MSCA

Misdirected CAMA call (7) (prefix digit dialed in error)

#### Local/Toll

This treatment is used in table STDPRTCL or table PFXTREAT for local calls that either attempt to switch through the toll network or dial the prefix digit 0 or 1 in error. Both call setups are not permitted.

#### ISDN

This treatment is used if the call is a local seven-digit direct dialed (DD) number as determined in table LCASCRN; the prefix digit 1 is dialed in error on a local call and the treatment to which the call is routed is datafilled as misdirected CAMA (MSCA) in table PFXTREAT.

Progress message contains network specific cause 3:

Prefix 1 dialed in error

and progress indicator 8:

In-band information or appropriate pattern not available

#### Gateway, Tandem

This treatment is redundant; set it to overflow or to a similar tone.

### MSLC

Misdirected local calls (8) (prefix digit not dialed)

#### Local, Local/Toll, Tandem

An operator-assisted call (0+) is originated to codes NPA555, 555, or 800.

A station ringer call is made if the last four digits do not match the calling line, and the call is not defined as no-prefix local in table PFXTREAT.

Prefix digit 0 or 1 is not dialed on a toll call, and table PFXTREAT specifies prefix digit mandatory on toll calls.

#### ISDN

This treatment is used under two conditions:

- The call is a 10-digit call and dialing of prefix digits is specified as mandatory in table LCASCRN.
- The prefix digit 1 is not dialed on a toll call and the treatment to which the call is routed is datafilled as MSLC (misdirected local call) in table PFXTREAT.

---

**TMTCNTL.TREAT** (continued)

---

Progress message contains network specific cause 4:

Prefix 1 not dialed

and progress indicator 8:

In-band information or appropriate pattern not available

**Toll, Gateway**

This treatment is redundant; set it to overflow or to a similar tone.

**MSOA**

Misdirected operator assisted announcement (0+ dialing not allowed)

**Local/Toll**

This treatment is used in table LCASCRCN to route unpermitted operator assisted (OA) calls to a pre-recorded announcement.

**ISDN**

This treatment is used if the prefix digit 0 is dialed in error as determined in table LCASCRN and the treatment to which the call is routed is datafilled as Y in field PFXFOR10 of table LCASCRN.

Progress message contains network specific cause 2:

Prefix 0 dialed in error

and progress indicator 8:

In-band information or appropriate pattern not available

**Gateway, Tandem**

This treatment is redundant; set it to overflow or to a similar tone.

**MTBL**

Mobile trouble

**MTOC**

MFC time out or confusion (115)

**Local/Toll, Tandem, Gateway**

This treatment is redundant; set it to overflow or to a similar tone.

**MWKP**

Mobile weak power

## TMTCNTL.TREAT (continued)

---

### **NACD**

Do not dial carrier access code (83)

#### **Local, Local/Toll (end office with Equal Access feature)**

10XXX is dialed for a carrier equal to field PIC in table LENFEAT for the subscriber.

Route the call to an announcement.

#### **Local/Toll (without the Equal Access feature), Gateway, Tandem**

This treatment is redundant; set it to overflow or to a similar tone.

### **NACK**

Negative acknowledgement (78)

#### **Local, Local/Toll (end office with custom calling features)**

This treatment is used when a feature request cannot be performed due to some feature interaction or feature restriction.

The NACK treatment is distinct from FNAL, where the subscriber attempts to use a custom calling feature that is not assigned to a line. For example, subscriber B call forwards to subscriber C; subscriber C is busy. Subscriber A dials subscriber B, hears busy tone, and attempts to RAG. The NACK treatment is returned because RAG is not permitted on a subscriber line that is call forwarded.

### **ISDN**

The facility is rejected, or service or option is not allowed.

Progress message contains cause 29:

Facility rejected

Local/Toll (without custom calling features)

#### **Gateway, Tandem**

This treatment is redundant; set it to overflow or to a similar tone.

### **NBLH**

Network blockage heavy traffic (9)

---

**TMTCNTL.TREAT** (continued)

---

**Local/Toll**

The immediate cause of failure is the inability to get a path through the network. This treatment is used if one of the following conditions exists:

- a second failed attempt for a CAMA position, operator or receiver
- no path on three-way call between a conference circuit and a trunk
- no network path on an operator-to-line call
- no network path to a metallic access trunk
- no network path to the line test unit on a station ringer test call
- no network path from a conference port to a called line

**Gateway**

The call incoming on a private line or R1 signaling trunk; the call is outgoing on a terminating 102 test line in the following states:

- an outgoing trunk is available, but it is in the wrong state (for example, not IDLE)
- an outgoing trunk is available, but the input or output control block (IOCB) cannot link
- an outgoing trunk is available, but there is no available network connection

If the call is incoming on a private line or international 101 test line; or the call is outgoing on a CCITT#5 (N5) signaling trunk, CCITT#6 (N6) signaling trunk, or international 101 test line, the following message is generated:

```
During call setup, terminating trunk found, but no call condense  
block available
```

If the call is incoming on an R1 signaling trunk; or the call is outgoing on an N6 signaling trunk or international 101 test line, the following message is generated:

```
During call setup, terminating trunk found, but no call condense  
block available
```

If the call is incoming on a private line, R1 signaling trunk, or an international 101 test line; or if the call is outgoing on a transmission test unit (ATME2), the following message is generated:

```
During call setup, cannot connect trunks because no network  
connection is available, or integrity not found over network  
connection
```

## **TMTCNTL.TREAT** (continued)

---

If the call is incoming on an R1 signaling trunk; or the call is outgoing on a terminating 104 test line, the following message is generated:

During call setup, outgoing trunk available, but no network connection available

If the call is incoming on a private line or an R1 signaling trunk, or if the call is outgoing on an international 101 test line, the following message is generated:

During call setup, two attempts to get network connection fail

If the call is incoming on an R1 signaling trunk, after call supervision, route the subscriber to an announcement if one of the following conditions exists:

- failed network connection
- failed announcement connection

The call should connect to announcement for the maximum number of announcement cycles.

### **Tandem**

Up to two attempts are made to reserve a network path from an incoming trunk to an outgoing trunk.

Up to two attempts are made to reserve a network path from an outgoing trunk to an audio tone detector.

### **ISDN**

There is switching equipment congestion.

Progress message contains cause 42:

Switching equipment congestion

### **NBLN**

Network blockage normal traffic (10)

### **Local/Toll**

This treatment is used if a call is aborted because of blocking (failure to get a channel) in the terminating peripheral module at the far end.

### **ISDN**

There is no circuit or channel available.

---

**TMTCNTL.TREAT** (continued)

---

The call cannot be completed from the calling interface because equipment or facilities are unavailable.

Progress message contains cause 34:

Circuit/channel congestion

and progress indicator 8:

In-band information or appropriate pattern not available

No channel is available at the calling interface because both B-channels are being used by other sets on loop, or because the set attempting to originate has an active call and the set did not request exclusive B-channel.

The network sends the calling subscriber a release complete message containing cause 34:

Bearer capability not implemented

The network cannot allocate the channel that the calling subscriber indicated as exclusive in the originating setup message.

The network sends the calling subscriber release complete message containing cause 44:

Requested channel not available

**Gateway, Tandem**

This treatment is redundant; set it to overflow or to a similar tone.

**NCII**

NCS invalid ID code (102)

**Tandem**

Action code 7 (invalid ID code) is received in the response message from the network control system (NCS). The ID code is a portion of the supplementary code collected from the subscriber.

**Local/Toll, Gateway**

This treatment is redundant; set it to overflow or to a similar tone.

**NCIX**

NCS incoming exclusion (101)

## **TMTCNTL.TREAT** (continued)

---

### **Tandem**

Action code 6 (incoming exclusion) is received in response message from NCS.

### **Local/Toll, Gateway**

This treatment is redundant; set it to overflow or to a similar tone.

## **NCRT**

No circuit (24)

### **Local/Toll, Tandem**

Routine call is deflected by network management to NCA.

Treatment can be specified by the network manager as an alternative to emergency 1 or 2 for calls aborted through operation of cancel-from or cancel-to network management controls.

With calls originating from a line or ATUP trunk or with calls outgoing on an ATUP trunk that signals a trunk during call connection, glare occurs on the outgoing trunk. A repeat attempt is not possible because a repeat was already attempted.

### **Gateway**

Call is incoming on a private line, R1 signaling trunk, or international 101 test line. Call is outgoing on an R1 signaling trunk.

During call connection, glare occurs on an outgoing trunk and a repeat attempt is not possible because of the following:

- one repeat was already attempted
- network management cancelled a repeat attempt
- an error occurred while expanding internal translation data
- an error occurred while condensing internal translation data

Call is incoming on a private line, R1 signaling trunk, or international 101 test line. Call is outgoing on an N5 signaling trunk.

During call connection, glare occurs between central control (CC) and an N5 peripheral module (PM) or between an N5 PM and far-end PM. A repeat attempt is not possible because of the following:

- one repeat was already attempted
- network management cancelled a repeat attempt

---

**TMTCNTL.TREAT** (continued)

---

- an error occurred while expanding internal translation data
- an error occurred while condensing internal translation data

Call is incoming on a private line, R1 signaling trunk, or international 101 test line. Call is outgoing on an R1 signaling trunk.

During call connection, an outgoing trunk registers call failure before the answer because of the following:

- no leading edge was received (similar to proceed to send)
- no start dial signal was received
- an unexpected off-hook was received

A repeat attempt is not possible because

- one repeat was already attempted
- network management cancelled a repeat attempt

Call is incoming on a private line, R1 signaling trunk, or international 101 test line. Call is outgoing on an N5 signaling trunk.

During call connection, an outgoing trunk registers a call failure before an answer because of the following:

- proceed to send message was not received
- proceed to send message was removed before seizure was removed
- proceed to send message was not removed
- release guard message was not received

A repeat attempt is not possible because of the following:

- one repeat was already attempted
- network management cancelled a repeat attempt

**ISDN**

This treatment is used if no circuit or channel is available, or if the requested circuit is not available.

The call cannot be completed from the calling interface because of unavailable equipment or facilities.



## **TMTCNTL.TREAT** (continued)

---

Progress message contains cause 34:

Circuit/channel congestion

and progress indicator 8:

In-band information or appropriate pattern not available

No channel is available at the calling interface because both B-channels are being used by other sets on the loop, or the set attempting to originate has an active call and the set did not request an exclusive B-channel.

The network sends a calling subscriber release complete message cause 34:

Bearer capability not implemented

The network cannot allocate the channel that the calling subscriber has indicated as exclusive in the originating setup message.

The network sends a calling subscriber release complete message cause 44:

Requested channel not available

### **NCTF**

NCS translation failure (103)

#### **Tandem**

The action code returned indicates one of the following NCS translation failures:

- 9-misdialed number
- 12-supplementary code required
- 13-outgoing trunk not found
- 14-ANI not found
- 15-NPA\_Nxx not found
- 16-pilot number not found
- 17-associated partition not found
- 18-agent data framework (ADF) format error
- 19-switch ID not found

#### **Local/Toll, Gateway**

This treatment is redundant; set it to overflow or to a similar tone.

---

**TMTCNTL.TREAT** (continued)

---

**NCUN**

NCS unexpected error (105)

**Tandem**

A Virtual Private Network (VPN) call is routed if action code 8 (unexpected error) in a response message is received from an NCS.

The action code returned by NCS is 5, or 23 to 63 (unused).

**Local/Toll, Gateway**

This treatment is redundant; set it to overflow or to a similar tone.

**NC8F**

NCS 800 service failure (128)

**Tandem**

The action code returned by NCS is one of the following:

- 20 800 number not found
- 21 800 number out of band
- 22 800 number no longer in service

**Local/Toll, Gateway**

This treatment is redundant; set it to overflow or to a similar tone.

**NECG**

Near end congestion (34)

**Local/Toll, Gateway**

This treatment is redundant; set it to overflow or to a similar tone.

**Gateway**

If the call is incoming on a private line, R1 signaling trunk, or international 101 test line, the following message is generated:

During call routing, all routes in route list are unavailable

If the call is incoming on a private line or international 101 test line, the following message is generated:

During call supervision or repeat attempt, call or previous call attempt fails due to network congestion

## TMTCNTL.TREAT (continued)

---

If the call is incoming on a private line, R1 signaling trunk, or international 101 test line, the following message is generated:

During translation verification, all routes in route list are unavailable

### **NINT**

Changed number intercept (99)

#### **Tandem**

The called number has been changed and can no longer be reached.

#### **Local/Toll, Gateway**

This treatment is redundant; set it to overflow or to a similar tone.

### **NMZN**

No metering zone (67)

#### **NONE**

This treatment handles billable calls if no metering zone is found in translations.

#### **Local/Toll, Gateway, Tandem**

This treatment is redundant; set it to overflow or to a similar tone.

### **NOCN**

No coin (50)

#### **Local, Local/Toll**

This treatment is used on a coin calling line if there is no coin present on chargeable call.

#### **Toll, Gateway, Tandem**

This treatment is redundant; set it to overflow or to a similar tone.

### **NOBC**

No bearer capability available (181)

#### **Gateway**

This treatment is used if the bearer capability (BC) is missing from the additional calling party information (ACPI) message.

#### **Local, Toll**

This treatment is redundant; set it to overflow or to a similar tone.

---

**TMTCNTL.TREAT** (continued)

---

**NONT**

Not on network (104)

**Tandem**

This treatment is used if a call conforms to the dialing plan but is not on the network. This treatment is datafilled as a route choice. For example, if area code 214 is not supported, table HNPACONT contains NONT as route choice for area code 214.

**Local/Toll, Gateway**

This treatment is redundant; set it to overflow or to a similar tone.

**NORA**

No routing available (182)

**Gateway**

This treatment is used if there is no routing information in the first indicator octet (FIO).

**Local, Toll**

This treatment is redundant; set it to overflow or to a similar tone.

**NOSC**

No service circuit (1)

**Local/Toll**

This treatment is used if all hardware resources are busy. Conditions include the following:

- all receivers, senders, or verification 90 (CLLI, VER90) trunks are busy
- the number of trunks queuing for the Centralized Automatic Message Accounting (CAMA) position trunk is equal to or greater than the quantity specified for field DEFLECT for the number of CAMA positions occupied in table CAMACSW
- no CAMA position is available after a second try
- operator queue overflow, including all queues for CAMA and TOPS operators
- no conference circuit is available
- time-out in CAMA queue, including all queues for CAMA and TOPS operators
- no metallic test access connection is available
- no resources for 108 test line call are available

## **TMTCNTL.TREAT** (continued)

---

- no tone or announcement available on an intercom call
- the last trunk group of group type VR (operator verification trunk) in a route list encounters on all trunks busy condition

### **Gateway**

This treatment is redundant; set it to overflow or to a similar tone.

### **Tandem**

This treatment is used if

- no recording units are available for Call Detail Recording (CDR) billing and the call is blocked as specified by office parameter CDR\_UNAVAIL\_BLOCK in table OFCVAR.
- echo suppression is specified but not available for test line calls (terminating to T100, T101, or T102).
- resources for conference calling are not available if the feature is activated (for example, six-port conference circuit is not allocated or office parameters controlling data resources for conference calls are not set properly)

### **ISDN**

This treatment is used is the call is not completed from the calling interface because of unavailable equipment or facilities.

Progress message contains cause 34:

Circuit/channel congestion

and progress indicator 8:

In-band information or appropriate pattern not available

If no channel is available at the calling interface because both B-channels are being used by other sets on the loop, or the set attempting to originate has an active call and the set did not request an exclusive B-channel, the network sends calling subscriber release complete message cause 34:

Bearer capability not implemented

If the network cannot allocate the channel that the calling subscriber indicated as exclusive in the originating setup message, then the network sends calling subscriber release complete message cause 44:

Requested channel not available

---

**TMTCNTL.TREAT** (continued)

---

**NOSR**

No software resource (93)

**Local/Toll**

This treatment is used if all software resources are busy. Conditions include the following:

- no multiblocks, recording units, or local automatic message accounting (LAMA) blocks are available
- no custom calling software resources are available, such as:
  - portperm extension block
  - custom calling feature extension block
  - supplementary data block
  - feature data block
- CPWAKEUP request cannot be scheduled

**ISDN**

The progress message contains cause 47:

Resource unavailable

**Gateway, Tandem**

This treatment is redundant; set it to overflow or to a similar tone.

**NPAR**

NPA restricted (111)

**Local/Toll, Gateway**

This treatment is redundant; set it to overflow or to a similar tone.

**Tandem**

This treatment is used if the subscriber dials an INWATS call, but the NPA is marked BLOCKED in table IEXCLUDE.

This treatment is also used if the subscriber dials a universal access code to obtain dial tone from a DMS-250 switch and then dials an 800 number.

**NTRS**

No terminal responding (133)

## **TMTCNTL.TREAT** (continued)

---

### **ISDN**

This treatment is used if the functional terminal fails to respond when it is offered a call.

The originating subscriber receives an audible ringback. To minimize the impact on the subscriber, continue to apply the ringback as generated by the tone as in the example in table TONES with CLLI code \*RING, before applying busy tone, followed by a lockout.

The progress message contains cause 18:

No user responding

### **Local/Toll, Gateway, Tandem**

This treatment is redundant; set it to overflow or to a similar tone.

### **NVIP**

Not very important person status (165)

### **Local/Toll, IBN**

This treatment is used on all calls made to NON-VIP subscribers in local exchange codes with undnVIP screening enabled.

### **N00B**

N00 call blocked (120)

### **Tandem**

This treatment is used in DMS-250 switches that have the CCS7 TCAP-based N00 service feature if the N00 number is blocked by a negative N00 database query.

### **Local/Toll, Gateway**

This treatment is redundant; set it to overflow or to a similar tone.

### **N9DF**

NCS 900 database failure (146)

### **Tandem**

This treatment is used if an NCS 900 database failure occurs in offices with the NCS 900 services feature.

### **Local/Toll, Gateway**

This treatment is redundant; set it to overflow or to a similar tone.

---

**TMTCNTL.TREAT** (continued)

---

**N9NS**

NCS 900 number not in service (148)

**Tandem**

This treatment is used if an NCS 900 number that is not in service occurs in offices with the NCS 900 services feature.

**Local/Toll, Gateway**

This treatment is redundant; set it to overflow or to a similar tone.

**N9OB**

NCS 900 number out of band (147)

**Tandem**

This treatment is used if an NCS 900 number out-of-band occurs in offices with the NCS 900 services feature.

**Local/Toll, Gateway**

This treatment is redundant; set it to overflow or to a similar tone.

**N950**

Do not dial 950 (81)

**Local, Local/Toll (end office with Equal Access feature)**

This treatment is used if the number 950-1xxx is dialed instead of 10xxx, if table OCCINFO field ACCESS is set to EAP.

Route the call to an announcement.

**Local/Toll (without Equal Access feature), Gateway, Tandem**

This treatment is redundant; set it to overflow or to a similar tone.

**OPRT**

Regular intercept (29)

**Local, Local/Toll**

This treatment is used if disconnected or out-of-service directory numbers are routed to an operator (regular intercept).

For information on assigning lines to this treatment, see the *SERVORD Reference Manual*.

**Toll, Gateway, Tandem**

This treatment is redundant; set it to overflow or to a similar tone.



## TMTCNTL.TREAT (continued)

---

### **ORAC**

Originating revertive action for two-party lines (42) with coded ringing

#### **Local, Local/Toll**

This treatment is used if a two-party line with coded ringing attempts to terminate to a party on the same line.

#### **Toll, Gateway, Tandem**

This treatment is redundant; set it to overflow or to a similar tone.

### **ORAF**

Originating revertive action for two-party lines (40) with frequency ringing

#### **Local, Local/Toll**

This treatment is used if a two-party line with frequency ringing attempts to terminate to a party on the same line.

#### **Toll, Gateway, Tandem**

This treatment is redundant; set it to overflow or to a similar tone.

### **ORMC**

Originating revertive action for multiparty lines (36) with coded ringing

#### **Local, Local/Toll**

This treatment is used if a multiparty line with coded ringing attempts to terminate on the same line.

#### **Toll, Gateway, Tandem**

This treatment is redundant; set it to overflow or to a similar tone.

### **ORMF**

Originating revertive action for multiparty lines (43) with frequency ringing

#### **Local, Local/Toll**

This treatment is used if multiparty line with frequency ringing attempts to terminate to a party on the same line.

#### **Toll, Gateway, Tandem**

This treatment is redundant; set it to overflow or to a similar tone.

### **ORSS**

Originating service suspension (27)

---

**TMTCNTL.TREAT** (continued)

---

**Local, Local/Toll**

This treatment is used if a call is originated on a line with the denied originating option or suspended service option assigned in table LENLINES or table IBNLINES.

**Toll, Gateway, Tandem**

This treatment is redundant; set it to overflow or to a similar tone.

**OSVR**

Operator services voice response (119)

**Local/Toll, Gateway, Tandem**

This treatment is redundant; set it to overflow or to a similar tone.

**OTAE**

Over The Air Activation Service Provisioning (OTASP) Error

This treatment is used when an error occurs during the processing of an OTASP call. When an error occurs during the processing of an OTASP call, the call is routed to this treatment, which provides the wireless subscriber a meaningful OTASP related explanation for the error.

**OTAR**

OTASP resources unavailable

This treatment is used if OTASP (over the air service provisioning) software or hardware resources or both are unavailable for a mobile call.

**PDIL**

Partial dial time out (2)

**Local/Toll, Tandem**

This treatment is used if one digit is received, but not all digits are required, to complete the call.

For calls on multifrequency (MF) trunks, PDIL instead of permanent signal (PSIG) is administered if the MF key pulse (KP) signal is received.

If the MF signaling terminal (ST) signal is not received, PDIL is the correct treatment. If the received ST signal is invalid in the context of the call, the proper treatment is RODR.

*Note:* Treatment CLLI COPP can be used as the first element in a route list.

## **TMTCNTL.TREAT** (continued)

---

### **Gateway**

This treatment is used for calls incoming on private or international 101 test lines.

This treatment is used for calls that fail during call digit collection

This treatment is used on calls incoming on R1 signaling trunks.

This treatment is used if the digit string has insufficient digits for translation during translation verification

This treatment is used for calls incoming on private or international 101 test lines.

There is an insufficient number of digits to complete translation during call translation

This treatment is used for calls incoming on a private line, R1 signaling trunk, or international 101 test line. This treatment is used for calls outgoing on CCITT6 signaling (N6) trunks.

This treatment is used if there are insufficient digits to complete a call. If the caller has transmitted digits to the terminating exchange, and the terminating exchange has received ST or timed out waiting for more digits

### **ISDN**

This treatment is used if there is an invalid number format or an incomplete address.

Progress message contains cause 28:

Incomplete number format

and progress indicator 8:

In-band information or appropriate pattern not available

### **Tandem**

This treatment is used in an international DMS-250 switch with the Call Back ISD feature. If the subscriber starts to dial after receiving the call back announcement, but fails to enter the minimum number of digits before PDIL (5 s, group parameter), then the call is taken down.

### **PERR**

Protocol error (168)

---

**TMTCNTL.TREAT** (continued)

---

**Local/Toll, IBN**

This treatment is used if the T33 signal timer expires before the information message (INF) is received.

**PER1**

Protocol error 1 (183)

**Gateway**

This treatment is used if the signaling capability and the signaling path indicator have conflicting information.

**Local, Toll**

This treatment is redundant; set it to overflow or to a similar tone.

**PER2**

Protocol error 2 (184)

**Gateway**

This treatment is used if the ITC and signaling path indicator have conflicting information.

**Local, Toll**

This treatment is redundant; set it to overflow or to a similar tone.

**PER3**

Protocol error 3 (185)

**Gateway**

This treatment is used if the protocol control indicators are set to invalid combinations in the initial address message (IAM).

**Local, Toll**

This treatment is redundant; set it to overflow or to a similar tone.

**PER4**

Protocol error 4 (186)

**Gateway**

This treatment is used if the protocol control indicators are set to invalid combinations in the address complete message (ACM).

**Local, Toll**

This treatment is redundant; set it to overflow or to a similar tone.

## TMTCNTL.TREAT (continued)

---

### **PER5**

Protocol error 5 (187)

#### **Gateway**

This treatment is used if the requested call path indicator (CPI) and service handling protocol (SHP) are an invalid combination.

#### **Local, Toll**

This treatment is redundant; set it to overflow or to a similar tone.

### **PNOH**

Permanent signal no receiver off-hook (32)

#### **Local/Toll, Gateway, Tandem**

This treatment is not available, set it to overflow or to a similar tone.

### **PNUN**

Private network unavailable (142)

This treatment is used if the Virtual Private Network cannot be accessed.

### **PODN**

Ported Out Directory Number

This treatment indicates that a directory number, whose office code (NPANXX) is native, has ported to another switch. PODN can be mapped to a tone or announcement.

### **RMID**

Remote Message Indicator Deactivation

This treatment is used by the Remote Message Indicator (RMI) feature. When an RMI subscriber dials the vertical access code which deactivates the RMI feature, the subscriber is offered the RMID treatment in order to confirm deactivation of the RMI feature.

### **PRSC**

Priority screen fail (57)

#### **Local/Toll, Gateway**

This treatment is redundant; set it to overflow or to a similar tone.

---

**TMTCNTL.TREAT** (continued)

---

**Tandem**

This treatment is used if the priority of the AUTHCODE subscriber is lower than the current office priority.

**PSIG**

Permanent signal time out (3)

**Local/Toll**

This treatment is used if no digits are received before a time-out condition occurs. Calls for which distorted signals are received (rather than none at all) are routed to reorder (RODR) treatment.

*Note:* Treatment CLLI COPP can be the first element in a route list for PSIG.

**Gateway**

This treatment is used if a call is incoming on a R1 signaling trunk:

If during call digit collection, the last received digit on an MF trunk and digit stream contain invalid ST and invalid KP

This treatment is used if a call is incoming on a R1 signaling trunk:

If during translation verification, there are not ST, no KP1, and no KP2 in digit stream

This treatment is used if a call is incoming on a private line, R1 signaling trunk, or international 101 test line:

During call digit collection, receiver times out waiting for digits

**Tandem**

This treatment is used if a call origination occurs on an incoming or two-way trunk, but no digits are dialed within the time specified by trunk subgroup value for PSPDSEIZ.

**Tandem**

This treatment is used in an international DMS-250 switch with the Call Back International Subscriber Dialed (ISD) feature. If subscriber does not answer callback within the time specified by office parameter CALL\_BACK\_ANSWER\_TIME in table OFCVAR (default 40 seconds), then the call is taken down.

**ISDN**

The destination is missing and direct call is not subscribed.

## TMTCNTL.TREAT (continued)

---

Progress message contains cause 90:

Dest missing

### **PTFL**

POTS pseudo service call failed (156)

#### **Gateway**

This treatment is used if an unauthorized attempt is made to use plain ordinary telephone service (POTS). The DMS-300 Service Screening by Destination on Issue feature must be present in the office.

#### **Local/Toll, Tandem**

This treatment is redundant; set it to overflow or to a similar tone.

### **PTOF**

Premature trunk offering (64)

#### **NONE**

This treatment is used if calls receive a trunk offering signal before translation is finished.

#### **Local/Toll, Gateway, Tandem**

This treatment is redundant; set it to overflow or to a similar tone.

### **RDIR**

Maximum number of redirections. The call links to an announcement that indicates that the maximum number of redirections has been reached.

### **RFCD**

Remote feature control denied

### **RFCE**

Remote feature control error

### **RFCS**

Remote feature control success

### **RING**

No terminal responding, release call (162)

---

**TMTCNTL.TREAT** (continued)

---

**ISDN**

This treatment is used if an ISDN terminal receives the message:

No terminal responding; release call

**Local/Toll, Gateway, Tandem**

This treatment is redundant; set it to overflow or to a similar tone.

**RMIA**

Remote Message Indicator Activation

This treatment is used by the Remote Message Indicator (RMI) feature. When an RMI subscriber dials the vertical access code which activates the RMI feature, the subscriber is offered the RMIA treatment in order to confirm activation of the RMI feature.

**RMID**

Remote Message Indicator Deactivation

This treatment is used by the Remote Message Indicator (RMI) feature. When an RMI subscriber dials the vertical access code which deactivates the RMI feature, the subscriber is offered the RMID treatment in order to confirm deactivation of the RMI feature.

**RODR**

Reorder (25)

**Local/Toll**

This treatment is used if distorted signals are received during dialing or impulsing. This includes instances of extra or mutilated pulses on incoming digits, noise during signaling, distorted frequencies, invalid ST control digits, or failure during ANI impulsing.

Also, the treatment can occur if an attempt is made to outpulse too many digits for trunk group type OP.

**Gateway**

This treatment is used if a call is incoming on a private line, R1 signaling trunk, or international 101 test line. Also affected are calls outgoing on R1 signaling trunks, N5 signaling trunks, N6 signaling trunks, or international 101 test lines.

During call routing, a selector in the chosen route list is unknown



## **TMTCNTL.TREAT** (continued)

---

This treatment is used for calls incoming on private lines, R1 signaling trunks, or international 101 test lines, and for calls outgoing on N6 signaling trunks.

A time out condition occurs, waiting for digits

For calls incoming on private lines, R1 signaling trunks, or international 101 test lines, failure during call translation occurs because of the following:

- invalid translation result
- invalid KP signal
- invalid signaling type (for example N7 signaling)

### **Tandem**

This treatment is used for the following conditions:

- the number of digits dialed is more than the maximum number of digits required for call
- for foreign exchange office (FXO) and foreign exchange station (FXS) circuits, a digit receiver is necessary but not available, or a receiver is obtained but no network path is available
- a valid speed number is dialed, but not enough digits are returned from the speed number database for translations to make a determination
- an unexpected error condition occurs on an outgoing trunk while a call is up (for example, network integrity loss, invalid A and B bit state received, or force release ordered from MAP position for terminating circuit)
- treatment set does not appear in trunk group-specific treatments subtable, or in subtable TMTCNTL.OFFTREAT

### **ISDN**

This treatment is used if the message is invalid or unspecified.

Progress message contains cause 28:

Incomplete number format

and progress indicator 8:

In-band information or appropriate pattern not available

### **RRPA**

Revertive ring prefix announcement (39)

### **Local/Toll, Gateway, Tandem**

Not currently available; set it to overflow or to a similar tone.

---

**TMTCNTL.TREAT** (continued)

---

**RSDT**

Restricted date and time (63)

**Local/Toll, Gateway**

This treatment is redundant; set it to overflow or to a similar tone.

**Tandem**

Restriction class in AUTHCODE does not allow subscriber to access network.

**RTEE**

Routing Error (dynamic) 217-255

**Local, Toll, Local/Toll, Tandem**

This treatment occurs when an intermediate switch receives an initial address message containing an ISUP hop counter (HC) value, and the HC value has expired. This causes a release (REL) message to be sent back through the network with a cause value set to "Exchange routing error".

**Gateway**

This treatment is redundant; set it to overflow or to a similar tone.

**SCA**

Selective call acceptance (157)

**Local**

Calling directory number is not found in the SCA list of terminating line with Custom Local Area Signaling Services (CLASS) SCA feature.

**Toll, Gateway**

This treatment is redundant; set it to overflow or to a similar tone.

**SCFL**

DBS communications failure (100)

**Tandem**

This treatment is used if

- a failure occurs in the communications link to NCS preventing processing of VPN calls
- a request is dropped because the wait\_for\_ack queue is full (VPN Transaction Processing feature)
- NCS communications software in the DMS-250 switch failed to respond after waiting 4 times the timeout value NCSTIMEOUT in table OFCENG

## **TMTCNTL.TREAT** (continued)

---

- error is detected in data received from NCS
- no communication links are available to NCS

### **Local/Toll, Gateway**

This treatment is redundant; set it to overflow or to a similar tone.

## **SCRJ**

Selective call rejection (150) local

### **Local**

The called line has activated the CLASS SCRJ feature and the calling number appears on its rejection list.

### **Toll, Gateway**

This treatment is redundant; set it to overflow or to a similar tone.

## **SCUN**

Service currently unavailable (109)

### **Local/Toll, Gateway**

This treatment is redundant; set it to overflow or to a similar tone.

### **Tandem**

Zero (0) + ONNET calls are routed. Zero (0) + ONNET calls do not allow operator access.

SCUN treatment is used in offices with Service Access Code (SAC) network management and Code Controls feature, if table INWATXLA indexes into card\_type CRTCARD (not supported).

## **SINT**

Service interception (125)

### **Tandem**

Universal translation tables are datafilled to route incorrectly dialed numbers (entered wrong, duplicated, and so on).

Route call to TOPS if the call is handled using the Service Interception (SVI) facility.

### **Local/Toll, Gateway**

This treatment is redundant; set it to overflow or to a similar tone.

---

**TMTCNTL.TREAT** (continued)

---

**SONI**

Service option not implemented (170)

**Local/Toll, IBN**

Invalid circuit existence indicator is received or TELESERVICE indicator is received from initial address message (IAM).

**SORD**

Storage overflow reorder (52)

**Tandem**

This treatment is used if the DMS-250 runs out of NCS extension blocks during translation of a VPN call.

This treatment is used if the DMS-250 runs out of FTR control blocks during a Travel Card Number Service (TCN) call origination.

**Local/Toll, Gateway**

This treatment is redundant; set it to overflow or to a similar tone.

**SORE**

Station origination restriction error (136)

**Local/Toll with MDC**

This treatment is used in offices with Meridian Digital Centrex (MDC) station origination restrictions (SOR) feature if a subscriber in a customer group with the SOR option attempts a call that is not allowed by the subscriber restriction level.

**Local/Toll without MDC, Gateway, Tandem**

This treatment is redundant; set it to overflow or to a similar tone.

**SRRR**

Single party revertive ringing (44)

**Local, Local/Toll**

This treatment is used for subscribers with the intercom option (single party revertive ringing).

If the switch office option INTERCOM is set to Y (yes) in table OFCOPT, a line with option intercom (INT) in table LENLINES, is routed to SRR if dialing own directory number to ring extension phone.

## **TMTCNTL.TREAT** (continued)

---

### **Toll, Gateway, Tandem**

This treatment is redundant; set it to overflow or to a similar tone.

### **SSTO**

Start signal time out (23)

### **Local/Toll**

This treatment is used if expected signals are not received from a far-end office during call setup. Expected signals are

- time out waiting for operator answer
- ANI outpulse failure or time-out (includes failures during outpulsing of called number or of ANI information)
- failure on outgoing trunks during ROTL tests

### **Gateway, Tandem**

This treatment is redundant; set it to overflow or to a similar tone.

### **STOB**

Signal time out BOC (71)

### **Local, Local/Toll (end office with Equal Access feature)**

This treatment is used if a call is completed in an Equal Access environment over an AT trunk, and the AT trunk does not get an EAEO wink.

### **Local/Toll (without Equal Access feature), Gateway, Tandem**

This treatment is redundant; set it to overflow or to a similar tone.

### **STOC**

Signal time out IC/INC (72)

### **Local, Local/Toll (end office with Equal Access feature)**

This treatment is used if a call is completed in an Equal Access environment over an AT trunk, and the EAEO/AT trunk does not get an IC/INC wink.

### **Local/Toll (without Equal Access feature), Gateway, Tandem**

This treatment is redundant; set it to overflow or to a similar tone.

### **SYFL**

System failure (14)

### **Local/Toll**

This treatment is used if a call is aborted because of a software or hardware switch failure.

---

**TMTCNTL.TREAT** (continued)

---

Failure type areas follows:

- call failure or integrity lost from port 1
- miscellaneous messages from port 2
- software failures or error conditions
- line-to-line, line-to-trunk, or trunk-to-line error takedown
- miscellaneous failures during overlap outpulsing
- miscellaneous error returns during set up
- called line module (LM) busy or under test
- failed Automatic Number Identification (ANI) test due to data error
- ANI failure on local Call Detail Recording (CDR) call
- data error
- failure in line number control processor
- integrity lost while receiving digits
- incoming or two-way CAMA trunk (trunk group type SC) with Bell format is routed if the start signal received is not the same as the one specified in field SDATA (subfield GRPTYPE) in table TRKGRP
- ring failure

**Gateway**

If this treatment is used for calls incoming on private lines, R1 signaling trunks, or international 101 test lines, the following error message is generated:

During call routing, routing procedure aborts

If this treatment is used for calls incoming on private lines, signaling trunks, or international 101 test lines, the following error message is generated:

During translation verification, routing procedure aborts

If this treatment is used for calls incoming on private lines, R1 signaling trunks, or international 101 test lines, the following error message is generated:

During call screening, call access table DCACCTL, and data in table is invalid

If this treatment is used for calls outgoing on N6 signaling trunks, the following error message is generated:

Call failure occurs

## TMTCNTL.TREAT (continued)

---

### **Tandem**

This treatment is redundant; set it to overflow or to a similar tone.

### **TBSY**

Toll busy (179)

### **Local, Local/Toll**

This treatment is used if a busy condition is encountered during a toll call attempt. The DMS switch determines if the call is a toll call, then routes to this treatment if it is unable to complete the call.

### **Toll, Gateway**

This treatment is redundant; set it to overflow or to a similar tone.

### **TDBR**

Test desk bridged (62)

### **Local, Local/Toll**

If an AT&T mechanized loop tester or a 14 local test desk (LTD) signaling type trunk (trunk group type TD) is connected to a line with option SUS, RSUS, PLP or RMB activated, and the trunk is connected in idle bridge mode to that line, the line routes to this treatment if either the test desk closes its tip or ring loop, or the line itself goes off-hook.

This treatment consists of a one second dial tone burst, then lockout.

### **Toll, Gateway, Tandem**

This treatment is redundant; set it to overflow or to a similar tone.

### **Recommended datafill**

For TDBR to function properly, the following tables must be datafilled as shown below:

- A pseudo CLLI must be datafilled in table CLLI.
- Table OFRT must contain an office route to point to entry DTBURST in table TONES.
- Table TMTCNTL.LNT must contain an entry for TDBR.
- Table TONES must be datafilled to provide the one second dial tone burst.

For table CLLI, the recommended datafill is

```
DTBURST <adnum> <trkgrpsiz> DIAL_TONE_BURST
```

**TMTCNTL.TREAT** (continued)

For table OFRT, the recommended datafill is

```
<number> S D DTBURST S D LKOUT $
```

For table TMTCNTL.LNT, the recommended datafill is

```
TDBR N T OFRT <number>
```

For table TONES, the recommended datafill is

```
DTBURST 0 100 1000000000000000 DIAL_TONE 7 10
```

**TDND**

Toll denied (21)

**Local/Toll**

This is the treatment that a line or trunk is routed to if one of the following conditions are encountered:

- a POTS or IBN line with the toll denied option (option TDN assigned in table LENLINES) originates a dial direct call that is not intercepted by class of service screening
- a coin line with toll denied option (option TDN assigned in table LENLINES) originates an operator assisted (OA) call that is not intercepted by class of service screening (where the switch has AMR5 signaling and a line other than coin, with toll denied option, originates a zero plus (0+) or zero minus (0-) call and field ZEROMPOS in table LINEATTR is other than AMR5)
- incoming or two-way CAMA/AMR5 (trunk group type SC) with AMR5 signaling format, if the category code requires toll denied treatment
- the category code to originating type toll denied is specified in table AMRCAT
- a POTS or IBN line routed to this treatment during toll call other than 1 555; 1 NPA555; or 1 800, and IBN line has toll denied restriction specified with direct outward dial access code in table IBNXLA

**Gateway, Tandem**

This treatment is redundant; set it to overflow or to a similar tone.

**TESS**

Terminating service suspension (28)



## **TMTCNTL.TREAT** (continued)

---

### **Local, Local/Toll**

This treatment is used if an incoming operator (trunk group type OI) verification call is made to a busy line with suspended service option (SUS) assigned in table LENLINES or table IBNLINES.

A call is made from a line or trunk to a line that has the option SUS assigned in table LENLINES or IBNLINES.

### **Local/Toll, Gateway, Tandem**

This treatment is redundant; set it to overflow or to a similar tone.

### **ISDN**

This treatment occurs if incoming calls are barred.

## **TINV**

Temporarily invalid authorization code (54)

### **Local/Toll, Gateway**

This treatment is redundant; set it to overflow or to a similar tone.

### **Tandem**

Status of authorization code is temporarily invalid.

## **TOVD**

Toll overload (37)

### **Local, Local/Toll**

This treatment is used if the calling line is denied access to toll network due to activation of Toll Network Protection feature.

### **Toll, Gateway, Tandem**

This treatment is redundant; set it to overflow or to a similar tone.

## **TRBL**

Trouble intercept (30)

### **Local, Local/Toll**

A call is routed to an incoming operator (trunk group type OI) verification call to busy line which has the plug up option (PLP) assigned in table LENLINES or IBNLINES.

A call is routed if a test desk (trunk group type TD) position tries to post a line using directory number (as opposed to LEN) dialing and the line has plug up (PLP) option assigned in table LENLINES or IBNLINES.

---

**TMTCNTL.TREAT** (continued)

---

A call is routed to TRBL if a line or trunk calls a line that has option plug up (PLP) assigned in table LENLINES or IBNLINES.

**ISDN**

This treatment is used for calls to DNs that are in a manually set trouble busy state.

Progress message contains cause 27:

Destination out of order

and progress indicator 8:

In-band information or appropriate pattern not available

**Toll, Gateway, Tandem**

This treatment is redundant; set it to overflow or to a similar tone.

**TRGB**

Trigger block

**TRRF**

Terminating revertive action for frequency ringing (41)

**Local, Local/Toll**

This treatment is required for local or combined local/toll switching units that have multiparty lines with frequency ringing.

This is the treatment that a called party is routed to if, upon going off-hook, both the calling and called parties share the same multiparty line provisioned with frequency ringing.

**Toll, Gateway, Tandem**

This treatment is redundant; set it to overflow or to a similar tone.

**UCCN**

Unpaid credit card number (144)

**Tandem**

This treatment is used in an international DMS-250 switch with Credit Card Calling feature (with or without remote database) if a credit card number is marked as UNPAID in table CCTAB.

The call is taken down once this treatment is applied.

## TMTCNTL.TREAT (continued)

---

### **Local/Toll, Gateway**

This treatment is redundant; set it to overflow or to a similar tone.

### **UNCA**

Unauthorized CAMA call (13)

### **Local/Toll, Gateway, Tandem**

This treatment is redundant; set it to overflow or to a similar tone.

### **UNDN**

Unassigned directory number (17)

### **Local/Toll**

This treatment is used if, for the digits dialed, the operating company has specified (in table DNROUTE), that treatment UNDN is to be applied.

### **Gateway**

Call incoming on private line, R1 signaling trunk, or international 101 test line.  
Call outgoing on N6 signaling trunk.

During call connection, terminating exchange determines that national number received has ceased to be used, and called subscriber must be reached by another number

### **ISDN**

Number is unassigned (unallocated).

Progress message contains network specific cause 1:

Vacant code

and progress indicator 8:

In-band information or appropriate pattern not available

### **Tandem**

This treatment is redundant; set it to overflow or to a similar tone.

### **UNDT**

Undefined treatment (0)

### **Local/Toll**

This is the default value for entries in class of service screening and prefix treatment tables if treatment is not required.

The standard datafill for this treatment should be T120.

---

**TMTCNTL.TREAT** (continued)

---

**Gateway, Tandem**

This treatment is redundant; set it to overflow or to a similar tone.

**UNIN**

Unauthorized INWATS call (22)

**Local/Toll**

This treatment is used in a toll or combined local/toll switch for the following types of calls:

- INWATS originating call if a 800 Nx2 number is dialed from outside the state and NX2 codes are reserved for intrastate calls
- INWATS originating call if an 800 NNx-xxxx number is dialed from within the state
- INWATS terminating call
  - if the call originated from a band that is farther away than the terminator has paid for to an INWATS line if the called number is not a valid INWATS number (800), the call is not direct dialed, or
  - if the call originates in the local free calling area and is therefore not billable

**Local/Toll AT or EAEO**

This treatment is used in an access tandem (AT) or equal access end office (EAEO) switch in service switching point (SSP) calls such as E800, 800+, and PVN, if there is a CCS7 application failure such as an invalid carrier identification for 800 calls.

**Tandem**

In offices with the Service Access Code (SAC) Network Management and Code Controls feature, treatment UNIN is provided if a call reaches the SACNWM selector in table HNPACONT without first having been declared a SAC call.

**Gateway**

This treatment is redundant; set it to overflow or to a similar tone.

**UNMC**

User Not Member of Closed User Group (CUG)

This treatment is used (set) by the Closed User Group service to indicate that an incoming ISUP call must be released with a cause value of #87 (User Not Member of CUG). This treatment is applied when, for example, an incoming

## TMTCNTL.TREAT (continued)

---

call with "CUG Without Outgoing Access" attempts to access a called user which is not subscribed to the CUG service.

### **UNOW**

Unauthorized OUTWATS call (20)

#### **Local, Local/Toll**

This is the treatment in a local or combined local/toll switch to which an OUTWATS line is routed if dialing an out-of-band code.

For information on assigning bands to codes, see table OWTZONES.

For information on assigning bands to OUTWATS lines, see table LENFEAT.

#### **Local/Toll, Gateway, Tandem**

This treatment is redundant; set it to overflow or to a similar tone.

### **UNPM**

Unprogrammed mobile

### **UPAB**

Universal public access blocked (135)

#### **Tandem**

This treatment is used if call origination by universal public address class (UPAC) phones is disallowed.

#### **Local/Toll, Gateway, ISDN**

This treatment is redundant; set it to overflow or to a similar tone.

### **VACS**

Vacant speed number (65)

#### **Tandem**

This treatment is used if a subscriber dials a number that is a public speed form, but the speed number is not in the database.

#### **Local/Toll, Gateway**

This treatment is redundant; set it to overflow or to a similar tone.

### **VACT**

Vacant code treatment (6)

---

**TMTCNTL.TREAT** (continued)

---

**Local/Toll**

This treatment is used if one of the following conditions is encountered:

- A line dials a toll terminating center code (code type TTC in table HNPACODE); operator code (code type OPC3, OPC4 or OPC5 in table HNPACODE); a terminating INWATS number (1XB-xxxx), a tandem INWATS number (0XB-NNx-xxxx); an NPA NPA code; or a number where the entry for the number in the foreign NPA code table (FNPA) specifies unauthorized CAMA.
- a 0 DA call including 0 411; 0 555; 0 NPA555; and 0 800. These calls are toll denied by setting the office parameter BLOCK\_0\_INF\_INW\_CALLS in table OFCVAR to Y (yes)
- An unassigned code in the country code table is dialed.
- No translation system is specified in the standard pretranslator subtable for digit or digits that have preroute selectors N, V, Z, R or P. This generates a software error message.
- There is an originating INWATS call, and no data is specified in table INWORICN for the INWATS number dialed.
- There is an originating INWATS call, if the originating screening office is also the terminating screening office, but no terminating service office (TSO) code has been specified in the INWATS originating control table for the NXX code dialed.
- There is a terminating INWATS call, if no data has been specified in the INWATS terminating control table for the incoming digits.
- A station ringer call and the last four digits do not match those of the calling line, and the call is defined as no prefix local.
- Blue box call cutoff occurs.
- A line-to-testline or operator-to-testline call occurs.
- There is failure to dial single party direct dial (SPDD) or single circuit.
- There is a failure or not enough digits on speed calling or call forwarding updates.
- There is a three-way call attempt to automatic number announcement, outgoing service desk, or revertive call.

**Gateway**

Call incoming on R1 signaling trunk.

## TMTCNTL.TREAT (continued)

---

During call digit collection, call failure occurs because of the following:

- no start dial
- integrity failure
- mutilated digit

The last digits received on MF trunk and digit stream contains a valid KP signal but the ST digit is one of the following:

- non-existent
- a second KP
- invalid

Call incoming on private line, R1 signaling trunk, or international 101 test line.  
Call outgoing on N6 signaling trunk.

Call has transmitted national number to terminating exchange, and terminating exchange has determined that transmitted national number is vacant or spare

Call incoming on private line, R1 signaling trunk, or international 101 test line.

During call screening, call failure occurs because of the following:

- call uses table DESTCTL and table not datafilled
- result from table DCACCTL is D

Call incoming on private line, R1 signaling trunk, or international 101 test line.

During call translation, call failure occurs because of the following:

- overseas call on trunk group that has NCTR specified against field CCTRNSL
- country code table specified on trunk group not datafilled
- terminating call to North America and table OVNTRNSL not datafilled
- subscriber dialed terminating call to North America with D or E digit equal to 0 or 1
- subscriber dialed terminating call to North America with digits NPA-555-xxxx
- number of digits received greater than maximum number specified in tables MMAX, INPRTRNS, or OVNTRNSL

---

**TMTCNTL.TREAT** (continued)

---

**Tandem**

This is the treatment to which a call is routed if an unassigned NPA code, office code, or country code is dialed, or incoming exclusion specifies that a call is to be blocked because a subscriber dialed a number in the local calling area.

**ISDN**

Number is unassigned (unallocated).

Progress message contains network specific cause 1:

Vacant code

and progress indicator 8:

In-band information or appropriate pattern not available

**VCCT**

Vacant country code treatment (95)

**Tandem**

This is the treatment to which a call is routed if call processing returns from translating an IDDD call as designated by the pretranslator (prefix digits 011 or 01), and there was no datafill for the network for country code dialing. This DMS-250 treatment applies to universal translations as well as normal international translations.

**Local/Toll, Gateway**

This treatment is redundant; set it to overflow or to a similar tone.

**VPFL**

Virtual private network call failure (155)

**Local, Local/Toll, IBN**

This treatment is used if a subscriber attempts a virtual private network (VPN) call, but does not subscribe to the service. Operational measurements and logs are kept to compile statistics on call attempts.

**Toll, Gateway**

This treatment is redundant; set it to overflow or to a similar tone.

**VPFX**

Vacant prefix code (138)



**TMTCNTL.TREAT** (continued)**Tandem**

This treatment is used in an international DMS-250 switch with Call Back International Subscriber Dialed (ISD) feature, if the XY (prefix) or ZZ (special service) digits are not datafilled correctly.

This treatment is used in an international DMS-250 switch with Credit Card Calling feature (with or without remote database), if the 00XY digits or the service code digits are not datafilled in translator.

The call is taken down once this treatment is applied.

**Local/Toll, Gateway**

This treatment is redundant; set it to overflow or to a similar tone.

**WUCR**

Wake-up call request (189)

**Local, Local/Toll, IBN, ISDN**

This treatment is used after a third attempt is made at a subscribers wakeup call. After an unsuccessful third attempt, the call is routed to this treatment and the event recorded in a log and also recorded as an operational measurement (OM).

**Toll, Gateway**

This treatment is redundant; set it to overflow or to a similar tone.

**Datafill**

The following tables lists datafill for subtable TMTCNTL.TREAT.

A description of field names for subtable TMTCNTL.TREAT if the treatment datafill consists of a CLLI from one of the tones in table TONES is shown in the table that follows.

**Field descriptions (Sheet 1 of 2)**

Field	Subfield	Entry	Explanation and action
TREATMT		alphanumeric (1 to 4 characters)	Treatment. Enter the treatment name.
LOG		Y or N	Log. Enter Y (yes) for a trunk or line message 138 printout each time translation is routed to a treatment. Otherwise, enter N (no).
FSTRTE		see subfields	First route. This field consists of subfields FSTRTSEL and CLLI.

**TMTCNTL.TREAT** (continued)**Field descriptions (Sheet 2 of 2)**

Field	Subfield	Entry	Explanation and action
	FSTRTSEL	S	First route selector. Enter the first route selector S.
	CLLI	alphanumeric (1 to 16 characters)	Common language location identifier. Enter the CLLI of the tone to which translation routes.

A description of field names for subtables TMTCNTL.TREAT if the treatment datafill points to a route list in table OFRT as shown in the table that follows.

*Note:* TABID entries for IBNTRE, IBNRT1, IBNRT2, IBNRT3, IBNRT4, TOPSAMA, RRTE, TTL4, and TOPS are not valid for table TMTCNTL, subtable TREAT.

**Field descriptions**

Field	Subfield	Entry	Explanation and action
TREATMT		alphanumeric (1 to 4 characters)	Treatment. Enter the treatment name.
LOG		Y or N	Log. Enter Y (yes) for a trunk or line message 138 printout each time translation is routed to a treatment. Otherwise, enter N (no).
FSTRTE		see subfields	First route. This field consists of subfields FSTRTSEL, TABID, and KEY.
	FSTRTSEL	T	First route selector. Enter the first route selector T.
	TABID	OFRT, OFR2, OFR3, or OFR4	Table name. Enter the office route table name.
	KEY	Table name. Enter the office route table name.	Key. Enter the index into the office route table which defines the route list for the treatment. The entry zero (0) cannot be datafilled by the operating company.

**Datafill example**

The following example shows sample datafill for table TMTCNTL.TREAT.

**TMTCNTL.TREAT** (continued)**MAP display example for table TMTCNTL.TREAT**

TREATMT	LOG		FSTRTE
UNDT	N	S	T120
RMIA	Y	T	OFRT 910
RMID	Y	T	OFRT 911

**Table history****NA013**

Added treatment CRTC to the range of values for the TREATMT field.

**EUR010**

Added treatment RDIR to the range of values for the TREATMT field. Activity AU3275.

**NA010**

Added treatments CMGA and CMGD to the range of values for the TREATMT field.

**NA009**

Added PODN treatment for LNP.

**NA008**

Added treatments RMIA and RMID.

**EUR006**

Added treatments FACJ and UNMC as part of ETSI ISDN world trade support. Added reference to operational measurements group, TRMTCU3.

**NA007**

Added treatments LNPM and QRNF for Local Number Portability (LNP).

Added treatments ICSD and ICSA.

**TL006**

Added treatments MSOA, ATHF, OTAR, UNPM, PNUN and ISAX.

**NA005**

Added treatment RTEE.

---

**TMTCNTL.TREAT** (end)

---

Added Exchange Routing Error (25) to the causemap table.

**NA004**

Treatments LDAA and LDAD were added.

**CSP02**

Added treatments AIND and AINF. A sentence was added to the explanation of treatment DNTR about the DN of an ACD INCALLS key.

---

## TMTMAP

---

### Table name

Treatment to Cause Map Table

### Functional description

Table TMTMAP provides mapping of DMS-100 treatments to call failure messages supported by certain Signaling System 7 protocols. Datafill in the table determines whether the treatment is reported to the preceding exchange (and if so, by what message), or whether the DMS switch applies the treatment locally, in which case the usual datafill in table TMTCNTL, subtable TREAT, determines the outcome.

Table TMTMAP also provides mapping of DMS-100 treatments for remote failure call scenarios between TS14 or ETSI PRI and AISUP, ANSI-ISUP, and I-ISUP calls.

For trunk type GTRK (global trunks), datafill table TRKTRMT instead of table TMTMAP.

There are as many variations in mapping of treatments to causes as there are protocols. However, for any protocol, there is only one fixed cause-to-treatment mapping that can occur in the DMS-100 switch.

Table TMTMAP changes the treatment-to-cause mapping, but before NA14 the cause-to-treatment mapping was fixed in DMS software. In NA14, the FLXCMAP table allows operating company personnel to assign a treatment to a cause.

The key to table TMTMAP is the signaling system protocol variant, the treatment code, and bearer capability. The protocol variant is an attribute of the incoming trunk and is derived from datafill in table TRKSGRP.

TS14 or ETSI PRI and AISUP, ANSI-ISUP, and I-ISUP calls do not datafill protocol variant PRI in table TRKSGRP.

Each time a new treatment code is added to subtable TMTCNTL.TREAT, tuples for the new treatment can be datafilled in table TMTMAP. For example, if a new treatment called FRED is created in an office with the software packages having ISUP, BTUP, TUPPLUS, DPNSS, and IBNISUP defined in them, the following key fields can be datafilled in table TMTMAP:

- ISUP FRED ALLBC
- BTUP FRED ALLBC
- TUPPLUS FRED ALLBC

## TMTMAP (continued)

---

- DPNSS FRED ALLBC
- IBNISUP FRED ALLBC

If an event is encountered that requires the application of a treatment for which a match in table TMTMAP cannot be found, CCS7 call processing software provides a default TMTMAPVAR for the unmatched treatment, which goes to Reorder (treatment 25). The default value is:

```
Q764 RODR ALLBC ISUP NOLOCAL NORMUNSP LOCLNET N
```

### Cause-to-treatment reference

If an originating or interworking office receives a CAUSE value in an ISUP release with a CAUSE message, the receiving office accesses table CAUSEMAP to map the CAUSE value back to a treatment and then applies the treatment.

*Note:* Unlike the contents of table TMTMAP, table CAUSEMAP is hard-coded and cannot be viewed or modified using the DMS table editor.

The following cross-reference tables have been completed to allow operating companies to reference treatments to causes.

The following conditions apply to the table:

- The cause descriptor is an internal DMS-100 long-form description for the cause indicator.
- The cause number is the American National Standards Institute (ANSI) cause value, a telecommunications industry standard number.
- The cause abbreviation is the value that can be viewed in table TMTMAP under field CAUSE, which is datafilled by the operating company.
- The treatment is a value that is datafilled in table TMTCNTL, subtable TREAT, which is datafilled in field TMT by the operating company.
- The treatment number is a value that is assigned to a TREATMENT and is referenced by number by operating company personnel.

**TMTMAP** (continued)**ISUP cause to DMS-100 treatment cross-reference (from table CAUSEMAP)**

Cause descriptor	Number	Cause abbreviation	Treatment	Number
ADDRESS_INCOMPLETE	28	ADDINCOM	PDIL	2
BC_NOT_AUTHORIZED	57	BCNAUTH	CNAC	113
BC_NOT_IMPLEMENTED	65	BCNIMPL	BCNI	161
BC_NOT_PRESENTLY_AVAIL	58	BCNAVAIL	CNAC	113
CALL_REJECTED	21	CALLREJ	CREJ	134
CHNLTYPE_NOT_IMPL	66	CHNLNIMP	CONP	98
DEST_OUT_OF_SERVICE	27	DOOSRVC	TRBL	30
EXCHANGE_ROUTING_ERROR	25	XLAFAIL	RTEE	dynamic 217-255
FACILITY_NOT_IMPL	69	FACNIMP	FCNI	167
FACILITY_REJECTED	29	FACREJ	RODR	25
IC_CALLS_BARR_CUG	55	INCBCUG (see note)	FNAL	68
INCOMPATIBLE_DEST	88	INCOMDST	CNAC	113
INTERWORKING_UNSPEC	127	INTWUNSP (see note)	RODR	25
INVALID_CALL_REF_VALUE	81	INVCINVAL (see note)	RODR	25
INVALID_MESSAGE	95	INVMSG (see note)	INVM	169
			RODR	25
INV_PARM_CONTENTS	100	INVPARMC (see note)	SSTO	23
MISDIALED_TRK_PREFIX	5	MISDTRPR (see note)	RODR	25
MISROUTED_CALL_TO_PORTED_NUMBER	26	MISRLNP	LNPM	dynamic 217-255
MSGTYPE_NOT_IMPL	97	MSGNIMPL (see note)	SSTO	23
NORMAL_CLEARING	16	NORMCLR	RODR	25

**Note:** Represents a CAUSE with a default treatment.

**TMTMAP** (continued)**ISUP cause to DMS-100 treatment cross-reference (from table CAUSEMAP)**

Cause descriptor	Number	Cause abbreviation	Treatment	Number
NO_ANS_FROM_USER	19	NOANSWER	ANTO	66
			RODR	25
NO_PREEMPT_CIRCUIT_AVAIL	46	NPMPTCKT	BLPR	47
CI_NO_CIRCUIT_AVAILABLE	34	NOCIRCAV	NOSC	1
NO_USER_RESPONDING	18	NOUSRESP	NTRS	133
NR_TO_DESTINATION	3	NRTODEST	VACT	6
NR_TO_TRANSIT_NTWK	2	NRTOTN	CACE	79
NTWK_OUT_OF_ORDER	38	NTWKOOO	SYFL	14
NORMAL_UNSPECIFIED	31	NORMUNSP	DISC	45
NUMBER_CHANGED	22	NUMCHANG	CNAC	113
OUTGOING_CALLS_BARRED	52	OTGCBARD	CNAD	137
PARAMETER_NOT_IMPL	99	PARMNIMP	IIEC	180
PARAM_NOT_IMPL_PASSED_ON	103	PNIPASS	SSTO	23
PREEMPTION	45	PREEMPT	PMPT	51
PROTOCOL_ERROR	111	PROTERR	PERR	168
			SSTO	23
REQ_CHANNEL_UNAVAIL	44	CHANUNAV	NCRT	24
RESOURCE_UNAVIALABLE	47	RESUNAV	NOSR	93
RESTRICTED_BC_INFO	70	RESBCINF	CNAC	113
SEND_SPECIAL_INFO_TONE	4	SSINFTN	RODR	25
SERV_OPT_NOT_AVAIL	63	SONAVAIL	NACK	78
SERV_OPT_NOT_IMPL	79	SONIMPL	FNAL	68
SWITCHING_EQUIP_CONG	42	SWEQCONG	FECG	35
<b>Note:</b> Represents a CAUSE with a default treatment.				



**TMTMAP** (continued)**ISUP cause to DMS-100 treatment cross-reference (from table CAUSEMAP)**

Cause descriptor	Number	Cause abbreviation	Treatment	Number
TEMPORARY_FAILURE	41	TEMPFAIL	CHNF	160
UNALLOCATED_NUMBER	1	UNALLOC	BLDN	18
			UNDN	17
USER_BUSY	17	USERBUSY	BUSY	19
USER_INFO_DISCARDED	43	UNIFDISC	RODR	25
USER_NOT_MEMBER_CUG	87	USERNCUG	UNMC	dynamic

**Note:** Represents a CAUSE with a default treatment.

**Note 1:** For causes 1, 17, and 27, when the calling party category in the ISUP IAM is equal to “test call”, the only valid cause values that can be provided are “User Busy”, “Destination out of Service”, or “Un-allocated Number”. The terminating party is assumed to be test equipment and if the terminating party is neither busy nor out of service (for example ringing time-out), a cause value of “Un-allocated Number” is returned.

**Note 2:** For cause 19, when the TMTPROC is set to LOCAL and the treatment is hit after the ACM message is sent, for example, ringing time-out of the called party, a PAM or a CPG (depending on XPM load) message with the properly coded cause value is sent to the originating switch. Otherwise, the cause value is coded in the Optional Backward Call Indicator of the ACM. This behavior also applies to ISLOCAL, INTLOCAL, ISDNLCL, and ISDNRTE TMTPROCs if the conditions for handling them locally are met (see definitions of these TMTPROCs for more information).

The following table lists the conditions that apply to each cause class treatment defined in table CAUSEMAP. In addition:

- The cause classes are taken from ANSI standards for ISUP causes.
- A generic treatment is assigned to a cause class in order to fit the class functionality. If new causes in a class are developed, the default treatment for the cause is used until a more appropriate treatment for a cause is developed.

**TMTMAP** (continued)

The table below details the class default treatments.

**ISUP cause indicator class default treatment table**

Cause class number	Cause indicator range description	Cause class range	Class default treatment
1	Normal event	0 to 31	RODR
2	Resource unavailable	32 to 47	NOSR
3	Service or option not available	48 to 63	FNAL
4	Service or option not implemented	64 to 79	NACK
5	Invalid message	80 to 95	RODR
6	Protocol error	96 to 111	SSTO
7	Interworking	112 to 127	RODR

The following table lists cause values mapped for ISUP to PRI and PRI to ISUP interworkings for the APC market.

**PRI cause to DMS-100 treatment cross-reference**

Cause descriptor	Number	Cause abbreviation	Treatment	Number
ADDRESS_INCOMPLETE	28	ADDINCOM	PDIL	2
BC_NOT_AUTHORIZED	57	BCNAUTH	SCUN	109
BC_NOT_IMPLEMENTED	65	BCNIMPL	BCNI	161
BC_NOT_PRESENTLY_AVAIL	58	BCNAVAIL	NOBC	181
CALL_REJECTED	21	CALLREJ	CREJ	134
REQUESTED_CIRCUIT_NOT_AVAILABLE	44	CHANUNAV	GNCT	58
CHNLTYPE_NOT_IMPL	66	CHNLNIMP	SONI	170
CHANNEL_UNACCEPTABLE	6	CHUNACC	CHNF	160
CALL_AWARDED_AND_BEING_DELIVERED_IN_AN_ESTABLISHED_STATE	7	CALLAWRD	CREJ	134

**Note:** Represents a CAUSE with a default treatment.

**TMTMAP** (continued)**PRI cause to DMS-100 treatment cross-reference**

<b>Cause descriptor</b>	<b>Number</b>	<b>Cause abbreviation</b>	<b>Treatment</b>	<b>Number</b>
DEST_OUT_OF_SERVICE	27	DOOSRVC	TESS	28
FACILITY_NOT_IMPL	69	FACNIMP	CREJ	134
FACILITY_REJECTED	29	FACREJ (see note)	NACK	78
IDENTIFIED_CHANNEL_DOES_NOT_EXIST	82	ICHNEXT	CHNF	160
INCOMPATIBLE_DEST	88	INCOMDST	CNAC	113
INTERWORKING_UNSPEC	127	INTWUNSP (see note)	CREJ	134
INVALID_CALL_REF_VALUE	81	INVCRVAL (see note)	PERR	168
INVALID_MESSAGE	95	INVMSG (see note)	SONI	170
INV_PARM_CONTENTS	100	INVPARMC (see note)	SONI	170
INVALID_TRANSIT_NETWORK_SELECTION	91	INVTNSEL	CREJ	134
MSGTYPE_NOT_IMPL	97	MSGNIMPL (see note)	SONI	170
MSGTYPE_NOT_COMPATIBLE	101	MSGNCWCS	SONI	170
MSGTYPE_NOT_COMPATIBLE_WITH_CALL_STATE	98	MSGNCWSMT	PERR	168
NORMAL_CLEARING	16	NORMCLR	CREJ	134
CI_NO_CIRCUIT_AVAILABLE	34	NOCIRCAV	GNCT	58
NO_USER_RESPONDING	18	NOUSRESP	NTRS	133
NR_TO_DESTINATION	3	NRTODEST	VACT	6
NR_TO_TRANSIT_NTWK	2	NRTOTN	CACE	79
NTWK_OUT_OF_ORDER	38	NTWKOOO	FECG	35
USER_ALERTING_NO_ANSWER	19	NOANSWER	CREJ	134
NORMAL_UNSPECIFIED	31	NORMUNSP	CREJ	134

**Note:** Represents a CAUSE with a default treatment.

**TMTMAP** (continued)**PRI cause to DMS-100 treatment cross-reference**

<b>Cause descriptor</b>	<b>Number</b>	<b>Cause abbreviation</b>	<b>Treatment</b>	<b>Number</b>
NON-SELECTED_USER_CLEARING	26	NSUSERESP	CREJ	134
NUMBER_CHANGED	22	NUMCHANG	CHAN	117
PARAMETER_NOT_IMPL	99	PARMNIMP	IIEC	180
PROTOCOL_ERROR	111	PROTERR	PERR	168
RESPONSE_TO_ENQUIRY	30	RSPTENQ	RODR	25
RESOURCE_UNAVAILABLE	47	RESUNAV	NOSR	93
RESTRICTED_BC_INFO	70	RESBCINF	SCUN	109
PARAMETER_NOT_PRESENT	96	REQINFNP	SONI	170
REQUESTED_FACILITY_NOT_SUBSCRIBED	50	RFACNSCRB	FNAL	68
RECOVERY_ON_TIMER	102	RONTMREXT	RODR	25
QUALITY_OF_SERVICE_UNAVAILABLE	49	QSVCUNAV	CREJ	134
SERV_OPT_NOT_AVAIL	63	SONAVAIL	SCUN	109
SERV_OPT_NOT_IMPL	79	SONIMPL	SONI	170
SWITCHING_EQUIP_CONG	42	SWEQCONG	NBLH	9
TEMPORARY_FAILURE	41	TEMPFAIL	SYFL	14
UNALLOCATED_NUMBER	1	UNALLOC	BLDN	18
USER_BUSY	17	USERBUSY	BUSY	19
USER_INFO_DISCARDED	43	UNIFDISC	RODR	25

**Note:** Represents a CAUSE with a default treatment.

---

**TMTMAP** (continued)

---

**Datafill sequence and implications**

The following tables must be datafilled before table TMTMAP:

- BCDEF
- TMTCNTL
- DNROUTE

Although the datafill in tables TMTMAP and TMTCNTL is closely related in the operation of this feature, there is no dependency that limits the datafill sequence. Default data is automatically added when the software load is prepared for each protocol variant in the switch. Because protocol variants depend on the software package, it is unlikely that all protocol variants will appear in one switch.

For trunk type GTRK (global trunks), datafill table TRKTRMT instead of table TMTMAP.

**Table size**

up to 3540 tuples

The total number of tuples is 0 to 256 times the number of protocols in the switching unit tuples. The current number of protocols available is 15. The absolute maximum number of tuples is 3584 ( $256 \times 15$ ).

When DPNSS is included in the load, the table is increased by a number of tuples equal to the number of treatment codes defined in the DMS-100 switch.

When BTUP is included in the load, the table minimum is 0, and the table maximum is 32767 tuples. Table size, set at entry time, depends on software; the number of tuples depends on the number of protocols added to table TMTMAP and the number of DMS-100 treatments.

No office parameters influence the table size or control store use.

Each tuple in table TMTMAP requires three bytes of data store memory. Memory is dynamically allocated.

**TMTMAP** (continued)**Datafill**

The following table lists datafill for table TMTMAP.

**Field descriptions**

Field	Subfield	Entry	Explanation and action
TMTMPKEY		see subfields	<i>Key to table TMTMAP</i> This field consists of subfields PROTOCOL, TMT, and BC_CT.
	PROTOCOL		<i>Protocol</i> Enter one of the following values:
		AISUP	Enter AISUP if this tuple applies to group type IBN7 trunks that are datafilled in table TRKSGRP with SIGDATA(C7UP) and PROTOCOL(ISUP).
		ATUP	Enter ATUP if this tuple applies to gateway type GW trunks that are datafilled in table TRKSGRP with SIGDATA(C7UP) and PROTOCOL(ATUP).
		BTUP	Enter BTUP if this tuple applies to trunks that are datafilled in table TRKSGRP with SIGDATA(C7UP) and PROTOCOL(BTUP).
		CCITT7	Enter CCITT7 if this tuple applies to IBN7 trunks that are datafilled in table TRKSGRP with SIGDATA(C7UP) and PROTOCOL(CCITT7).
		DPNSS	Enter DPNSS if this tuple applies to trunks that are datafilled in table TRKSGRP with SIGDATA(DPNSS).
		IBNISUP	Enter IBNISUP if this tuple applies to IBN7 trunks that are datafilled in table TRKSGRP with SIGDATA(C7UP) and PROTOCOL(IBNISUP).
		ISUP	Enter ISUP if this tuple applies to IBN7 trunks that are datafilled in table TRKSGRP with SIGDATA(C7UP) and PROTOCOL(ISUP).
		JPNISUP	Enter JPNISUP if this tuple applies to type IBN7 trunks that are datafilled in table TRKSGRP with SIGDATA(C7UP) and PROTOCOL(JPNISUP).

**TMTMAP** (continued)**Field descriptions**

Field	Subfield	Entry	Explanation and action
		NCCI7	Enter NCCI7 if this tuple applies to type IBN7 trunks that are datafilled in table TRKSGRP with SIGDATA(C7UP) and PROTOCOL(NCCI7).
		Q764	Enter Q764 if this tuple applies to type IBN7 trunks that are datafilled in table TRKSGRP with SIGDATA(C7UP) and PROTOCOL(Q764).
		Q767	Enter Q767 if this tuple applies to type IBN7 trunks that are datafilled in table TRKSGRP with SIGDATA(C7UP) and PROTOCOL(Q767).
		R2	Enter R2 if this tuple applies to gateway (GW) type trunks that are datafilled in table TRKSGRP with SIGDATA(C7UP) and PROTOCOL(R2).
		SSUTR2	Enter SSUTR2 if this tuple applies to the French TUP protocol.
		TUP	Enter TUP if this tuple applies to type GW trunks that are datafilled in table TRKSGRP with SIGDATA(C7UP) and PROTOCOL(TUP).
		TUPE	Enter TUPE if this tuple applies to type GW trunks that are datafilled in table TRKSGRP with SIGDATA(C7UP) and PROTOCOL(TUPE).
		TUPPLUS	Enter TUPPLUS if this tuple applies to type GW trunks that are datafilled in table TRKSGRP with SIGDATA(C7UP) and PROTOCOL(TUPPLUS).
		PRI	Enter PRI if this tuple applies to ISUP to PRI and PRI to ISUP interworkings.  <b>Note:</b> In the UK market, the protocols available on the DMS-100 switch may be limited, depending on the switch load.

**TMTMAP** (continued)

**Field descriptions**

Field	Subfield	Entry	Explanation and action
	TMT	alphanumeric (1 to 4 characters)	<i>Treatment code</i> Enter one of the treatment codes defined in table TMTCNTL.TREAT, field TREATMT.  This is the treatment that is applied to the specific ISUP cause value indicated in field CAUSE.
	BC_CT	ALLBC, SPEECH, VOICE, DATA, 64KDATA, 56KDATA, 3_1KHZ, or 7_KHZ	<i>Bearer capability call type</i> Enter the specific bearer capability call type that is mapped differently from other bearer capability call types.  The default value is ALLBC, meaning that all bearer capability call types are mapped to the same treatment.  Bearer capability types must be datafilled in table BCDEF before they can be datafilled in subfield BC_CT.  <b>Note:</b> Changing the value of this subfield on BTUP or DPNSS trunks may not have any effect.
TMTMPVAR		see subfield	<i>Treatment MAP</i> This field consists of selector field FORMAT.
	FORMAT	alphanumeric	<i>Protocol format</i> Enter one of the following values:  ATUP           ATUP for PROTOCOL(ATUP) BTUP           BTUP for PROTOCOL(BTUP) TUPPLUS       TUPPLUS for PROTOCOL(TUPPLUS) R2              R2 for PROTOCOL(R2) IBNISUP       IBNISUP for PROTOCOL(IBNISUP) TUPE           TUPE for PROTOCOL(TUPE) DPNSS         DPNSS for PROTOCOL(DPNSS)



**TMTMAP** (continued)**Field descriptions**

Field	Subfield	Entry	Explanation and action
		ISUP	PROTOCOL(AISUP), PROTOCOL(CCITT7), PROTOCOL(ISUP), PROTOCOL(JPNISUP), PROTOCOL(NCCI7), PROTOCOL(Q764), or PROTOCOL(Q767)  <b>Note:</b> In the UK market, the protocol formats available on the DMS-100 switch may be limited, depending on the switch load.
		PRI	PRI for PROTOCOL(PRI)
		SSUTR2	SSUTR2 for the French TUP protocol

**FORMAT = ATUP**

If the entry in field FORMAT is ATUP, datafill the following refinements.

**Field descriptions for conditional datafill**

Field	Subfield	Entry	Explanation and action
	TMTPROC	see subfield	<i>ATUP treatment procedure format</i> This field consists of selector field TMTPROC and refinements.  This field determines what action an ATUP gateway trunk takes upon encountering a treatment.
	TMTPROC	LOCAL	<i>ATUP treatment procedure selector</i> Enter one of the following values:  Enter LOCAL and leave remaining refinements blank if the treatment is applied locally, according to datafill in table TMTCNTL, subtable TREAT.  An in-band tone or announcement is generated, depending on the treatment code in table TMTCNTL, subtable TREAT.
		NOLOCAL	Enter NOLOCAL and datafill refinements MSG and LOG if the user notification is given from a switching office closer to the calling party.

**TMTMAP** (continued)

**Field descriptions for conditional datafill**

Field	Subfield	Entry	Explanation and action
	MSG	ADI, CFL, CGC, FRL, ISC, LOS, NNC, RIN, SCC, SEC, SLI, SSB, SST, or UNN	<i>ATUP failure message</i> This field specifies the ATUP failure message sent.
	LOG	Y or N	<i>Generate log</i> Enter Y (yes) to indicate that a TRK138 log is generated, depending on the datafill in table TMTCNTL, subtable TREAT. Otherwise enter N (no).  The treatment route list in table TMTCNTL, subtable TREAT is not used, but the Log Report field is. Therefore, a TRK138 log only appears if the particular treatment code has the Log Report enabled in both tables.  For TMTPROC(LOCAL), leave this field blank.

**FORMAT = BTUP**

If the entry in field FORMAT is BTUP, datafill the following refinements.

**Field descriptions for conditional datafill**

Field	Subfield	Entry	Explanation and action
	TMTPROC	see subfield	<i>BTUP treatment procedure format</i> This field consists of selector field TMTPROC and refinements.  This field determines what action a BTUP gateway trunk takes upon encountering a treatment.
	TMTPROC		<i>BTUP treatment procedure selector</i> Enter one of the following values:

**TMTMAP** (continued)**Field descriptions for conditional datafill**

Field	Subfield	Entry	Explanation and action
		LOCAL	<p>Enter LOCAL and leave remaining refinements blank if the treatment is applied locally, according to datafill in table TMTCNTL, subtable TREAT.</p> <p>An in-band tone or announcement is generated, depending on the treatment code in table TMTCNTL, subtable TREAT.</p>
		NOLOCAL	<p>Enter NOLOCAL and complete refinements BTUPMSG, AFTERACM, and LOG if the user notification is given from a switching office closer to the calling party.</p> <p>This is achieved by sending in the backward direction (toward the originating exchange) a BTUP message that advises the exchange of a call and indicates the reason, so that the originating exchange can take appropriate action.</p> <p>The sending of this message initiates a sequence that releases the incoming trunk, thereby reducing the holding time for calls that are routed to treatment.</p>
	BTUPMSG	see subfields	<p><i>BTUP pre-ACM failure message</i></p> <p>This field consists of selector field PREACM and PREACM value-dependent refinement.</p> <p>This field specifies the failure message that is sent if the treatment occurs prior to the generation of a BTUP address complete message (ACM).</p> <p>If treatment occurs after sending an ACM, the AFTERACM field is consulted instead.</p>
	PREACM		<p><i>BTUP pre-ACM fail message selector</i></p> <p>Enter the BTUP message sent, if the treatment occurs prior to the generation of a BTUP address complete message (ACM) by entering one of the following values:</p>
		CNA	Connection not admitted. Also complete refinement CNACAUSE.
		CONG	Congestion. Leave the refinement field blank.

**TMTMAP** (continued)**Field descriptions for conditional datafill**

Field	Subfield	Entry	Explanation and action
		REL	Release. Also complete refinement RELCAUSE.
		SEN	Subscriber engaged. Leave the refinement field blank.
		S000	Subscriber out of order. Leave the refinement field blank.
		STR	Subscriber transferred. Leave the refinement field blank.
		TCON	Terminal congestion. Leave the refinement field blank.
	CNACAUSE	0 to 255	<p><i>BTUP CNA cause</i> Enter the reason parameter, in the form of an integer, that appears in the BTUP connection not admitted (CNA) message.</p> <p>Aside from checking the range 0 to 255, the DMS switch does not validate the integer against the values defined in the BTUP specification (BNTR 167, Section 3, Issue 2).</p>
	RELCAUSE	0 to 255	<p><i>BTUP release cause</i> Enter the reason parameter, in the form of an integer, that appears within the BTUP release (REL) message.</p> <p>Aside from checking the range 0 to 255, the DMS switch does not validate the integer against the values defined in the BTUP specification (BNTR 167, Section 3, Issue 2).</p>
	AFTERACM	see subfield	<p><i>BTUP after-ACM failure message</i> This field consists of selector REL and refinement RELCAUSE. The field specifies the BTUP failure message sent if the treatment occurs after the DMS switch generates a BTUP address complete message (ACM).</p>

**TMTMAP** (continued)**Field descriptions for conditional datafill**

Field	Subfield	Entry	Explanation and action
	REL	REL	<i>BTUP after-ACM failure message selector</i> Enter the type of BTUP message sent if the treatment occurs after the DMS switch has generated a BTUP address complete message (ACM) by entering REL. The only current type is REL.
	RELCAUSE	0 to 255	<i>BTUP after-ACM release cause</i> Enter the reason parameter, in the form of an integer, that appears in the REL message.  Aside from checking the range 0 to 255, the DMS switch does not validate the integer against the values defined in the BTUP specification (BNTR 167, Section 3, Issue 2).
	LOG	Y or N	<i>Generate log</i> Enter Y (yes) to indicate that a TRK138 log report is generated if field LOG in table TMTCNTL, subtable TREAT is set to Y for the treatment code.  The route list field FSTRTE of table TMTCNTL, subtable TREAT is not used.  Enter N (no) if a log report is not required.  For TMTPROC(LOCAL), leave this field blank.

**FORMAT = DPNSS**

If the entry in field FORMAT is DPNSS, datafill the following refinements.

**Field descriptions for conditional datafill**

Field	Subfield	Entry	Explanation and action
	TMTPROC	see subfields	<i>Treatment procedure</i> This field consists of selector field TMTPROC.
	TMTPROC	LOCAL	<i>Treatment procedure selector</i> Enter one of the following values:  Enter LOCAL and leave refinements CAUSE and LOG blank if the treatment is always applied locally.

**TMTMAP** (continued)

**Field descriptions for conditional datafill**

Field	Subfield	Entry	Explanation and action
		NOLOCAL	Enter NOLOCAL and datafill refinements CAUSE and LOG if the treatment is mapped into backward failure information.
	CAUSE	AB, ACK, AI, BY, CHOS, CNR, CON, CT, FNR, ICB, INC, MISRLNP, MNU, NT, NU, PFR, REJ, ROS, SI, SNU, SOS, SNV, SSI, STU, SU, TRFD, or UNR	<p><i>Clearing cause</i> This field specifies the DPNSS clear request message (CRM) returned.</p> <p>For TMTPROC(LOCAL), leave this field blank.</p>
	LOG	Y or N	<p><i>Generate log</i> Enter Y (yes) to indicate that a TRK138 log is generated if the datafill in table TMTCNTL, subtable TREAT is used.</p> <p>The treatment route list in table TMTCNTL, subtable TREAT is not used, but the Log Report field is.</p> <p>Therefore, a TRK138 log only appears if the particular treatment code has the Log Report enabled in both tables. Otherwise, enter N (no).</p> <p>For TMTPROC(LOCAL), leave this field blank.</p>

**FORMAT = IBNISUP**

If the entry in field FORMAT is IBNISUP, datafill the following refinements.

**Field descriptions for conditional datafill**

Field	Subfield	Entry	Explanation and action
	TMTPROC	see subfield	<p><i>Treatment procedure</i> This field consists of selector field TMTPROC.</p>
	TMTPROC		<p><i>Treatment procedure selector</i> Enter one of the following values:</p>

**TMTMAP** (continued)**Field descriptions for conditional datafill**

Field	Subfield	Entry	Explanation and action
		LOCAL	Enter LOCAL and leave refinement MSG and LOG blank if treatment is always applied locally.
		NOLOCAL	<p>Enter NOLOCAL and datafill refinements MSG and LOG if the user notification is given from a switching office closer to the calling party.</p> <p>This is done by sending, in the backwards direction (towards the originating exchange), an IBNISUP message that advises the exchange of a call, and indicates the reason so that the originating exchange can take appropriate action.</p> <p>The sending of this message initiates a sequence that releases the incoming trunk, thereby reducing the holding time for calls that are routed to treatment.</p>
	MSG	ACB, ADI, CFL, CGC, DPN, LOS, MPR, NNC, SEC, SSB, SST, or UNN	<p><i>IBNISUP failure message</i> This field specifies the IBNISUP failure message sent.</p> <p><b>Note:</b> A requirement of the IBNISUP protocol is that an EUM message cannot be generated on IBNISUP trunks. Therefore, entry EUM is not allowed in field MSG.</p>
	LOG	Y or N	<p><i>Generate log</i> Enter Y (yes) to indicate that a TRK138 log is generated, depending on the datafill in table TMTCNTL, subtable TREAT. Otherwise enter N (no).</p> <p>The treatment route list in table TMTCNTL, subtable TREAT is not used, but the Log Report field is. Therefore, a TRK138 log only appears if the particular treatment code has the Log Report enabled in both tables.</p> <p>For TMTPROC(LOCAL), leave this field blank.</p>

**TMTMAP** (continued)**FORMAT = ISUP**

If the entry in field FORMAT is ISUP, datafill the following refinements.

**Field descriptions for conditional datafill**

Field	Subfield	Entry	Explanation and action
	ISUPPROC	see subfield	<i>ISUP procedure</i> This field consists of selector subfield TMTPROC.
	TMTPROC		<i>Treatment procedure selector</i> Enter one of the following values:
		INTLOCAL	Enter INTLOCAL (interworking local) and datafill refinements CAUSE and LOG if the treatment is applied locally.  The other conditions required for the use of INTLOCAL are: <ul style="list-style-type: none"> <li>• The ISDNUP indicator bit must be set to NOT_ISUP_ALL_THE_WAY.</li> <li>• The treatment is mapped to a cause and included in a release message if the ISDNUP indicator bit is set to other than NOT_ISUP_ALL_THE_WAY.</li> </ul>
		ISDNLCL	Enter ISDNLCL (ISDN local) and datafill refinements CAUSE and LOCATION for the treatment that sends a properly coded ACM (ISUP address complete message) to the originating switch only if: <ul style="list-style-type: none"> <li>• The originating agent is a basic rate access functional (BRAf) set.</li> <li>• The connection is ISUP_ALL_THE_WAY.</li> <li>• A treatment is applied at the local switch.</li> </ul>



**TMTMAP** (continued)**Field descriptions for conditional datafill**

Field	Subfield	Entry	Explanation and action
		ISDNRTE	<p>Enter ISDNRTE (ISDN remote) and datafill refinements CAUSE and LOCATION for the treatment that sends a properly coded ACM (ISUP address complete message) to the originating switch only if:</p> <ul style="list-style-type: none"> <li>• The originating agent is a BRAF set.</li> <li>• The connection is ISUP_ALL_THE_WAY.</li> <li>• A treatment is applied at a remote switch over per-trunk signaling (PTS) facilities.</li> </ul>
		ISLOCAL	<p>Enter ISLOCAL (ISUP local) and complete refinement fields CAUSE, LOCATION, and LOG if the treatment is applied locally.</p> <p>The other conditions required for the use of ISLOCAL are:</p> <ul style="list-style-type: none"> <li>• The ISDNUP indicator bit must be set to ISUP_ALL_THE_WAY.</li> <li>• The treatment is mapped to a cause and included in a release message if the ISDNUP indicator bit is set to other than ISUP_ALL_THE_WAY.</li> </ul>
		LOCAL	<p>Enter LOCAL and leave refinements CAUSE and LOG blank if the treatment is always applied locally.</p>
		NOLOCAL	<p>Enter NOLOCAL and datafill refinements CAUSE, LOCATION and LOG if the treatment is mapped to a cause and always included in a release message.</p>

**TMTMAP** (continued)**ISUP normal event class (0 to 31)**

If the entry in field FORMAT is ISUP, the entry in field TMTPROC is any entry other than LOCAL, and the class is normal event (0 to 31), datafill the following refinements.

**Field descriptions for conditional datafill**

Field	Subfield	Entry	Explanation and action
	CAUSE		ISUP cause. Enter one of the following values:
		ADDINCOM	Address incomplete  This cause indicates that the called party cannot be reached because the number is not in a valid format or is not complete.
		CALLREJ	Call rejected  This cause indicates that the equipment sending this cause does not wish to accept this call, although it could have accepted the call because the equipment sending this cause is neither busy or incompatible.
		DOOSRVC	Destination out of service  This cause indicates that the called party cannot be reached because the interface to the destination is not functioning correctly.  The term <i>not functioning correctly</i> indicates that a signaling message could not be delivered to the called party. This could be caused by a physical layer or data link layer failure at the called party, user equipment off-line, or other.
		FACREJ	Customer interface facility rejected  This cause indicator is sent on receipt of a facility request message from a signaling link.
		MISDTRPR	Misdialed trunk prefix  Not specified for North American networks.
		MISRLNP	LNP misrouted a call to a ported number.  This cause indicates that an LNP call to a ported number was misrouted.

**TMTMAP** (continued)**Field descriptions for conditional datafill**

Field	Subfield	Entry	Explanation and action
		NOANSWER	<p>No answer from user, user alerting</p> <p>This cause is used if the called party has been alerted but does not respond with a connect indication (answer). The ringing time-out value is set using office parameter RNG_TMEOUT_NO_OF_SECS in table OFCENG.</p> <p>The network sends a call clearing message to the calling user.</p>
		NORMCLR	<p>Normal call clearing</p> <p>This cause indicates that the call is being cleared because one of the users involved in the call has requested that the call be cleared. In a normal situation, the source of this cause is not the network.</p>
		NRTODEST	<p>No route to destination</p> <p>This cause indicates that the called party cannot be reached because the network through which the call has been routed does not serve the destination desired. This cause is supported on a network-dependent basis.</p>
		NOUSRESP	<p>No user responding</p> <p>This cause is used if a called party does not respond to a call establishment message with either an alerting or connect indication within the prescribed period of time.</p>
		NORMUNSP	<p>Normal, unspecified</p> <p>This cause is used to report a normal event only if no other cause in the normal class applies.</p>

**TMTMAP** (continued)**Field descriptions for conditional datafill**

Field	Subfield	Entry	Explanation and action
		NUMCHANG	<p>Number changed</p> <p>This cause is returned to a calling party if the called number indicated by the calling party is no longer assigned. The new called number can optionally be included in the diagnostic field.</p> <p>If a network does not support this capability, unallocated number must be used.</p>
		NRTOTN	<p>No route to specified transit network</p> <p>This cause indicates that the equipment sending this cause has received a request to route the call through a particular transit network, either because the transit network does not exist or because the particular transit network, while it does exist, does not serve the equipment that is sending the cause. This cause is supported on a network-dependent basis.</p>
		SSINFTN	<p>Send special information tone</p> <p>This cause indicates that the called party cannot be reached for reasons that are of long-term nature and that the special information tone should be returned to the calling party.</p>
		UNALLOC	<p>Unallocated number</p> <p>This cause indicates that the called party cannot be reached, although the number is in a valid format, because it is not currently assigned (unallocated).</p>
		USERBUSY	<p>User busy</p> <p>This cause is used if the called party has indicated the inability to accept another call. It is noted that the user equipment is compatible with the call.</p>

**TMTMAP** (continued)**Field descriptions for conditional datafill**

Field	Subfield	Entry	Explanation and action
		XLAFAIL	This cause occurs when an intermediate switch receives an initial address message (IAM) containing an ISUP hop counter (HC) value, and the HC value has expired. This causes a release (REL) message to be sent back through the network with a cause value set to "Exchange routing error".
		XLAFAIL_ ANSI	This cause occurs when an intermediate switch receives an initial address message (IAM) containing an ISUP hop counter (HC) value, and the HC value has expired. This causes a release (REL) message to be sent back through the network with a cause value set to "Exchange routing error".  This entry will set the coding standard to National (ANSI) for this cause.

**ISUP resource unavailable class (32 to 47)**

If the entry in field FORMAT is ISUP, the entry in field TMTPROC is any entry other than LOCAL, and the class is resource unavailable (32 to 47), datafill the following refinements.

**Field descriptions for conditional datafill**

Field	Subfield	Entry	Explanation and action
	CAUSE		<i>ISUP cause</i> Enter one of the following values:
		CHANUNAV	Requested channel unavailable Not specified.
		NOCIRCAV	No circuit available  This cause indicates that there is no appropriate circuit presently available to handle the call.
		NPMPTCKT	Reserved field

**TMTMAP** (continued)**Field descriptions for conditional datafill**

<b>Field</b>	<b>Subfield</b>	<b>Entry</b>	<b>Explanation and action</b>
		NTWKOOO	<p>Network out of order</p> <p>This cause indicates that the network is not functioning correctly and that the condition is likely to last a relatively long period of time. Immediately re-attempting the call is not likely to be successful.</p>
		PREEMPT	<p>Preemption</p> <p>This cause indicates that the equipment sending this cause has pre-empted the circuit for a new call and the existing call should be cleared.</p>
		RESUNAV	<p>Resource unavailable, unspecified</p> <p>This cause is used to report a resource unavailable event only when no other cause in the resource unavailable class applies.</p>
		SWEQCONG	<p>Switching equipment congestion</p> <p>This cause indicates that the switching equipment generating this cause is experiencing a period of high traffic.</p>

**TMTMAP** (continued)**Field descriptions for conditional datafill**

Field	Subfield	Entry	Explanation and action
		TEMPFAIL	<p>Temporary failure</p> <p>This cause indicates that the network is not functioning correctly and that the condition is not likely to last a long time.</p> <p>The user can attempt another call almost immediately.</p>
		UINFDISC	<p>User information discarded</p> <p>This cause indicates that the network could not deliver user information to the remote user as requested.</p> <p>The type of information that could not be delivered includes user-to-user information, low layer compatibility, high layer compatibility, or subaddress, as indicated in the diagnostic.</p> <p>The particular type of user information discarded is optionally included in the diagnostic.</p>

**ISUP service not-available class (48 to 63)**

If the entry in field FORMAT is ISUP, the entry in field TMTPROC is any entry other than LOCAL, and the class is service not-available (48 to 63), datafill the following refinements.

**Field descriptions for conditional datafill**

Field	Subfield	Entry	Explanation and action
	CAUSE		<p><i>ISUP cause</i></p> <p>Enter one of the following values:</p>
		BCNAUTH	<p>Bearer capability not authorized</p> <p>This cause indicates that the user has requested a bearer capability that is implemented by the equipment that generated this cause but the user is not authorized to use it.</p>

**TMTMAP** (continued)**Field descriptions for conditional datafill**

Field	Subfield	Entry	Explanation and action
		BCNAVAIL	Bearer capability not presently available  This cause indicates that the user has requested a bearer capability that is implemented by the equipment which generated this cause but that is not available at this time.
		INCBCUG	IC_CALLS_BARR_CUG A TR846 ISDN cause.
		OTGCBARD	OUTGOING_CALLS_BARRED Call not allowed. A TR846 ISDN cause.
		SONAVAIL	Service or option not available, unspecified  This cause is used to report a service or option not available event only if no other cause in the service or option not available class applies.

**ISUP service not-implemented class (64 to 79)**

If the entry in field FORMAT is ISUP, the entry in field TMTPROC is any entry other than LOCAL, and the class is service not-implemented (64 to 79), datafill the following refinements.

**Field descriptions for conditional datafill**

Field	Subfield	Entry	Explanation and action
	CAUSE		<i>ISUP cause</i> Enter one of the following values:
		BCNIMPL	Bearer capability not implemented  This cause indicates that the equipment sending this cause does not support the bearer capability requested.
		CHNLNIMP	Channel type not implemented  Not specified.
		FACNIMP	Facility not implemented  This cause indicates that the requested facility is not implemented and therefore cannot be accessed at this time.



**TMTMAP** (continued)**Field descriptions for conditional datafill**

Field	Subfield	Entry	Explanation and action
	CAUSE	RESBCINF	<p>Restricted bearer capability information</p> <p>Only restricted digital information bearer capability is available.</p> <p>This cause indicates that the calling party has requested an unrestricted version of the requested bearer capability.</p>
		SONIMPL	<p>Service or option not implemented, unspecified</p> <p>This cause is used to report a service or option not-implemented event only if no other cause in the service or option not-implemented class applies.</p>

**ISUP invalid message class (80 to 95)**

If the entry in field FORMAT is ISUP, the entry in field TMTPROC is any entry other than LOCAL, and the class is invalid message (80 to 95), datafill the following refinements.

**Field descriptions for conditional datafill**

Field	Subfield	Entry	Explanation and action
	CAUSE		<p><i>ISUP cause</i></p> <p>Enter one of the following values:</p>
		INCOMDST	<p>Incompatible destination</p> <p>This cause indicates that the equipment sending this cause has received a request to establish a call that has low layer compatibility or high layer compatibility attributes (for example, data rate) that cannot be used for this call.</p>
		INVCRVAL	<p>Invalid call reference value</p> <p>This cause indicates that the equipment sending this cause has received a message with a call reference that is not currently in use.</p>

**TMTMAP** (continued)**Field descriptions for conditional datafill**

Field	Subfield	Entry	Explanation and action
		INVMSG	Invalid message, unspecified  This cause is used to report an invalid message event only if no other cause in the invalid message class applies.
		USERNCUG	CDN_USER_NOT_IN_CUG

**ISUP protocol error class (96 to 111)**

If the entry in field FORMAT is ISUP, the entry in field TMTPROC is any entry other than LOCAL, and the class is protocol error (96 to 111), datafill the following refinements.

**Field descriptions for conditional datafill**

Field	Subfield	Entry	Explanation and action
	CAUSE		<i>ISUP cause</i> Enter one of the following values:
		INVPARMC	Invalid parameter contents  This cause indicates that the equipment sending this cause has received a parameter that it has implemented, but for which one or more of the fields in the parameter are coded in a way that has not been implemented by the equipment sending this cause.
		MSGNIMPL	Message type non-existent or not implemented  This cause indicates that the equipment sending this cause has received a message with a message type it does not recognize either because this is a message not defined or defined but not implemented by the equipment sending this cause.
		PARMNIMP	Parameter non-existent or not implemented  This cause indicates that the equipment sending this cause has received a message with optional parameters not recognized because the parameter name is not defined or it is defined but not implemented by the equipment sending the cause.

**TMTMAP** (continued)**Field descriptions for conditional datafill**

Field	Subfield	Entry	Explanation and action
		PNIPASS	Parameter not implemented passed on This cause can be due to either of the following events: <ul style="list-style-type: none"> <li>An invalid circuit indicator is received.</li> <li>A tele-service indicator is received in an Initial Address Message (IAM).</li> </ul>
		PROTERR	Protocol error, unspecified This cause is used to report a protocol error event only if no other cause in the protocol error class applies.

**ISUP interworking class (112 to 127)**

If the entry in field FORMAT is ISUP, the entry in field TMTPROC is any entry other than LOCAL, and the class is interworking (112 to 127), datafill the following refinements.

**Field descriptions for conditional datafill**

Field	Subfield	Entry	Explanation and action
	CAUSE		<i>ISUP cause</i> Enter the following value:
		INTWUNSP	Interworking, unspecified This cause indicates that there has been interworking with a network that does not provide a cause for action it takes. The precise cause for the message cannot be determined.

**TMTMAP** (continued)**FORMAT = ISUP (continued)**

If the entry in field FORMAT is ISUP, continue datafill by datafilling the following refinements.

**Field descriptions for conditional datafill**

Field	Subfield	Entry	Explanation and action
	LOCATION		<p><i>Cause indicator location</i></p> <p>Enter the LOCATION value included in the cause indication parameter (CIP) included in ISUP ACMs (CCS7 address complete message) and RELs (CCS7 Release message), if the message is sent as part of a treatment.</p> <p>The LOCATION field is stored as a unique 4-bit value in the CIP.</p> <p>The value of the LOCATION field varies with call scenarios, but the common denominator of all these scenarios is that the public network is serving the local user.</p> <p>This field is only applicable if TMTPROC is not LOCAL. The default value is LOCLNET.</p>
		INTLNET	Enter INTLNET if the cause value in the release message is to reference an international switching office.
		LICBS	Enter LICBS if the cause value in the release message is to reference a local interface controlled by a signaling link.
		LOCLNET	Enter LOCLNET if the cause value in the release message is to reference a local public switching office.
		PRIVNET	Enter PRIVNET if the cause value in the release message is to reference an local private switching office.
		RLOCLNET	Enter RLOCLNET if the cause value in the release message is to reference a remote public switching office.
		RPRIVNET	Enter RPRIVNET if the cause value in the release message is to reference a remote private switching office.

**TMTMAP** (continued)**Field descriptions for conditional datafill**

Field	Subfield	Entry	Explanation and action
		SP1	Reserved for future use
		SP2	Reserved for future use
		TRANSNET	Enter TRANSNET if the cause value in the release message is to reference a transit network switching office.
		UNKNOWN	Enter UNKNOWN if the cause value in the release message is to indicate that the switching office location is unknown.
		USER	Enter USER if the cause value in the release message is to reference the user's switching office.
	LOG	Y or N	<p><i>Generate log</i> Enter Y (yes) to generate a TRK138 log if a release with cause is sent. Otherwise, enter N (no).</p> <p>For TMTPROC(LOCAL), leave this field blank.</p>

**FORMAT = R2**

If the entry in field FORMAT is R2, datafill the following refinements.

**Field descriptions for conditional datafill**

Field	Subfield	Entry	Explanation and action
	TMTPROC	see subfields	<p><i>Treatment procedure</i> This field consists of selector subfield TMTPROC.</p>
	TMTPROC		<p><i>Treatment procedure selector</i> Enter one of the following values:</p>
		LOCAL	Enter LOCAL and leave refinements MSG and LOG blank if the treatment is always applied locally.

**TMTMAP** (continued)**Field descriptions for conditional datafill**

Field	Subfield	Entry	Explanation and action
		NOLOCAL	<p>Enter NOLOCAL and datafill refinements MSG and LOG if the user notification is given from a switching office closer to the calling party.</p> <p>This is achieved by sending, in the backwards direction (towards the originating exchange), an R2 message that advises the exchange of a call, and indicates the reason so that the originating exchange can take appropriate action.</p> <p>The sending of this message initiates a sequence that releases the incoming trunk, thereby reducing the holding time for calls that are routed to treatment.</p>
	MSG	ACB, ADI, CFL, CGC, DPN, LOS, MPR, NNC, SEC, SSB, SST, or UNN	<p><i>IBNISUP failure message</i> This field specifies which IBNISUP failure message is sent.</p> <p><b>Note:</b> A requirement of the IBNISUP protocol is that EUM message cannot be generated on R2 trunks. Therefore, EUM is not an allowable entry in field MSG.</p>
	LOG	Y or N	<p><i>Generate log</i> Enter Y (yes) to indicate that a TRK138 log is generated if the datafill in table TMTCNTL, subtable TREAT.</p> <p>The treatment route listed in table TMTCNTL, subtable TREAT is not used, but the Log Report field is.</p> <p>Therefore, a TRK138 log only appears if the particular treatment code has the Log Report enabled in both tables. Otherwise, enter N (no).</p> <p>For TMTPROC(LOCAL), leave this field blank.</p>

**TMTMAP** (continued)**FORMAT = SSUTR2**

If the entry in field FORMAT is SSUTR2, datafill the following refinements.

**Field descriptions for conditional datafill**

Field	Subfield	Entry	Explanation and action
	TMTPROC	see subfield	<p><i>SSUTR2 treatment procedure format</i> This field consists of selector field TMTPROC and refinements.</p> <p>This field determines what action an FTUP trunk takes upon encountering a treatment.</p>
	TMTPROC		<p><i>SSUTR2 treatment procedure selector</i> Enter one of the following values:</p>
		LOCAL	<p>Enter LOCAL and leave remaining refinements blank if the treatment is applied locally, according to datafill in table TMTCNTL, subtable TREAT.</p> <p>An in-band tone or announcement is generated, depending on the treatment code in table TMTCNTL, subtable TREAT.</p>
		NOLOCAL	<p>Enter NOLOCAL and datafill refinements MSG and LOG if the user notification is given from a switching office closer to the calling party.</p> <p>The default value is NOLOCAL.</p>

**TMTMAP** (continued)**Field descriptions for conditional datafill**

Field	Subfield	Entry	Explanation and action
	MSG	ACB, ADI, CFL, CGC, LOS, NNC, SEC, SSB, or UNN	<i>SSUTR2 failure message</i> This field specifies the SSUTR2 failure message sent. The default treatment is CFL.
	LOG	Y or N	<i>Generate log</i> Enter Y (yes) to indicate that a TRK138 log is generated, depending on the datafill in table TMTCNTL, subtable TREAT. Otherwise enter N (no). The default value is N. The treatment route list in table TMTCNTL, subtable TREAT is not used, but the Log Report field is. Therefore, a TRK138 log only appears if the particular treatment code has the Log Report enabled in both tables. For TMTPROC(LOCAL), leave this field blank.

**FORMAT = TUPE**

If the entry in field FORMAT is TUPE, datafill the following refinements.

**Field descriptions for conditional datafill**

Field	Subfield	Entry	Explanation and action
	TMTPROC	see subfield	<i>Treatment procedure</i> This field consists of subfield TMTPROC.
	TMTPROC		<i>Treatment procedure selector</i> Enter one of the following values:
		LOCAL	Enter LOCAL and leave refinements MSG and LOG blank if the treatment is always applied locally.



**TMTMAP** (continued)**Field descriptions for conditional datafill**

Field	Subfield	Entry	Explanation and action
		NOLOCAL	Enter NOLOCAL and datafill refinements MSG and LOG if the user notification is given from a switching office closer to the calling party. This is achieved by sending in the backwards direction (towards the originating exchange) a TUPE message that advises the exchange of a call and indicates the reason, so that the originating exchange can take appropriate action. The sending of this message initiates a sequence that releases the incoming trunk, thereby reducing the holding time for calls that are routed to treatment.
	MSG	ACB, ADI, CFL, CGC, DPN, LOS, MPR, NNC, SEC, SSB, SST, or UNN	<p><i>TUPE failure message</i> This field specifies the TUPE failure message sent.</p> <p><b>Note:</b> A requirement of the TUPE protocol is that EUM message cannot be generated on TUPE trunks. EUM is not an allowable value in this field.</p>
	LOG	Y or N	<p><i>Generate log</i> Enter Y (yes) to indicate that a TRK138 log is generated if the datafill in table TMTCNTL, subtable TREAT.</p> <p>The treatment route list in table TMTCNTL, subtable TREAT is not used, but the Log Report field is. Therefore, a TRK138 log only appears if the particular treatment code has the Log Report enabled in both tables. Otherwise enter N (no).</p> <p>For TMTPROC(LOCAL), leave this field blank.</p>

**TMTMAP** (continued)

**FORMAT = TUPPLUS**

If the entry in field FORMAT is TUPPLUS, datafill the following refinements.

**Field descriptions for conditional datafill**

Field	Subfield	Entry	Explanation and action
	TMTPROC	see subfields	<p><i>TUPPLUS treatment procedure</i> This field consists of selector subfield TMTPROC.</p> <p>This field determines the action taken by a TUP+ gateway trunk after the trunk is routed to treatment.</p>
	TMTPROC		<p><i>Treatment procedure selector</i> Enter one of the following values:</p>
		LOCAL	<p>Enter LOCAL and leave remaining refinements blank if the treatment is applied locally according to datafill in table TMTCNTL, subtable TREAT.</p> <p>An in-band tone or announcement is generated, depending on the treatment code in table TMTCNTL, subtable TREAT.</p>
		NOLOCAL	<p>Enter NOLOCAL and datafill refinements MSG, Q931, and LOG if the user notification is given from a switching office closer to the calling party.</p> <p>This is achieved by sending, in the backwards direction (towards the originating exchange), a TUP+ message that advises the exchange of a call, and indicates the reason so that the originating exchange can take appropriate action.</p> <p>The sending of this message initiates a sequence that releases the incoming trunk, thereby reducing the holding time for calls which are routed treatment.</p>

**TMTMAP** (continued)**Field descriptions for conditional datafill**

Field	Subfield	Entry	Explanation and action
	MSG	see subfield	<p><i>TUP+ failure message</i> This field consists of selector subfield MSGCODE.</p> <p>This field specifies what TUP+ failure message is sent.</p> <p><b>Note:</b> Optionally, the Q931 field may be datafilled to define a different failure message that applies specifically to calls originated from ISDN Q.931 access. (The distinction, if needed, operates from information in the Initial Address message with Additional information (IAI)).</p>
	MSGCODE		<p><i>TUP+ failure message selector</i> Select the TUP+ message sent by entering one of the following values:</p>
		ACB	Access barred (heading code H1 1010). Leave the refinement field blank.
		ADI	Address incomplete (heading code H1 0100). Leave the refinement field blank.
		CFL	Call failure (heading code H1 0101). Leave the refinement field blank.
		CGC	Circuit group congestion (heading code H1 0010). Leave the refinement field blank.
		EUM	Extended unsuccessful backward set-up information message (heading code H1 1111). Datafill refinement EUMCAUSE.
		LOS	Line out of service (heading code H1 1000). Leave the refinement field blank.
		NNC	National network congestion (heading code H1 0011). Leave the refinement field blank.
		NRU	Network resource unavailable (heading code H1 1101). Leave the refinement field blank.
		SEC	Switching equipment congestion (heading code H1 0001). Leave the refinement field blank.

**TMTMAP** (continued)**Field descriptions for conditional datafill**

Field	Subfield	Entry	Explanation and action
		SSB	Subscriber busy (heading code H1 0110). Leave the refinement field blank.
		SST	Send special information tone (heading code H1 1001). Leave the refinement field blank.
		UNN	Unallocated number (heading code H1 0111). Leave the refinement field blank.
	EMUCAUSE	0 to 255	<i>TUP+ EUM failure message cause</i> Enter the reason parameter, in the form of an integer, that appears in the TUP+ extended unsuccessful backward setup information message (EUM).  Aside from checking the range 0 to 255, the DMS switch does not validate the integer against the values defined in the TUP+ specification T/SPS-43-02 Q723+.
	Q931	see subfield	<i>Alternate TUP+ failure message</i> This field consists of selector subfield Q931.  This field allows the specification of different TUP+ messages for use with calls identified (from information in the initial address message with additional information (IAI)) as Q.931 access.

**TMTMAP** (continued)**Field descriptions for conditional datafill**

Field	Subfield	Entry	Explanation and action
	Q931	ACB, ADI, CFL, CGC, EUM, LOS, NNC, NRU, SEC, SSB, SST, UNN, or \$	<p><i>Alternate TUP+ failure message selector</i> Enter one of two choices:</p> <ul style="list-style-type: none"> <li>\$ to indicate that no Q931 distinction is necessary. (In this case, the message given by the MSG field is used for all calls without regard to the Q.931 access marking.)</li> <li>the TUP+ message code sent for calls having originated from Q.931 access as described in fields MSGCODE and EUMCAUSE</li> </ul>
	LOG	Y or N	<p><i>Generate log</i> Enter Y (yes) to indicate that a TRK138 log report is generated if field LOG in table TMTCNTL, subtable TREAT is set to Y for the treatment code.</p> <p>The route list field FSTRTE of table TMTCNTL, subtable TREAT is not used.</p> <p>Enter N (no) if a log report is not required.</p> <p>For TMTPROC(LOCAL), leave this field blank.</p>

**FORMAT = PRI****Field descriptions for conditional datafill**

Field	Subfield	Entry	Explanation and action
	TMTPROC	see subfield	<p><i>Treatment procedure</i> This field consists of subfield TMTPROC.</p>
	TMTPROC	LOCAL	<p><i>Treatment procedure selector</i> Enter one of the following values:</p> <p>Enter LOCAL and leave refinements CAUSE and LOG blank if the treatment is always applied locally.</p>

## TMTMAP (continued)

### Field descriptions for conditional datafill

Field	Subfield	Entry	Explanation and action
		NOLOCAL	Enter NOLOCAL and datafill refinements CAUSE and LOG if the user notification is given from a switching office closer to the calling party.
	CAUSE	PRI_CAUSE	Enter the cause value to send to the originating PRI trunk.
	LOG	Y or N	Enter Y to generate a TRK138 log. For TMTPROC (LOCAL), leave this field blank.

### Datafill example

The following example shows sample datafill for table TMTMAP.

#### MAP display example for table TMTMAP

TMTMPKEY	TMTMPVAR					
Q764	NOSC	ALLBC	ISUP	NOLOCAL	NOCIRCAV	LOCLNET N

#### MAP display example for table TMTMAP ISUP hop counter value exceeded

TMTMPKEY	TMTMPVAR					
Q764	RTEE	ALLBC	ISUP	NOLOCAL	XLAFAIL_ANSI	LOCLNET Y

#### MAP display example for table TMTMAP Q767 ISUP extended treatment - User Not Member of Closed User Group (CUG)

TMTMPKEY	TMTMPVAR					
Q767	UNMC	ALLBC	ISUP	NOLOCAL	USERNCUG	RPRIVNET N

**TMTMAP** (continued)**MAP display example for table TMTMAP Q767 ISUP extended treatment - Facility Rejected**

TMTMPKEY	TMTMPVAR
Q767	FACJ ALLBC ISUP NOLOCAL FACREJ RPRIVNET N

**Table history****SN07 (DMS)**

Added new cause value XLAFAIL\_ANSI to map cause value of “exchange routing error” using a coding standard of National (ANSI) if needed.  
CR Q00760514-10.

**NA014**

Added reference to the FLXCMAP table which allows operating company personnel to assign a treatment to a cause.

**MMP13**

Added protocol SSUTR2 for French TUP.

**CCM11**

Added causes MISRLNP, OTGCBARD, INCBUCG, and USERNCUG.

**APC009**

Added protocol variant PRI and conditional datafill applicable to ISUP to PRI interworkings.

**NA009**

Added treatment MISROUTED\_LNP\_NUMBER.

Treatment PODN added to range of values in field TMTMAP\_KEY.TMT

**EUR006**

Added two treatments, FACJ (facility rejected) and UNMC (user not member of closed user group (CUG)), to support World Trade ETSI ISUP services.

**NA007**

Added treatment MISROUTED\_CALL\_TO\_PORTED\_NUMBER (LNPM).

Added table sequence information about table DNROUTE.

**EUR004**

Added protocol selector Q767 to support ETSI ISUP V1.

**NA005**

CSE\_25 under the CAUSE field was replaced with XLAFAIL to map the new cause value of exchange routing error to the relevant treatment in accordance with ISUP Hop Counter.

**APC004**

Added conditional datafill for FORMAT=ATUP.

**UK002**

The following changes were made:

- Added table size information (DPNSS and BTUP)
  - Revised BTUP entry in field TMTMPKEY, subfield PROTOCOL
- Added UK market note under fields PROTOCOL and FORMAT



# TMZONE

## Table name

TOPS Time Zone Variation Table

## Functional description

Table TMZONE is used to specify, in min, the time difference between the local time of an NPA-NXX point served by the Traffic Operator Position System (TOPS) and the local time of TOPS itself. The default value is 0 (zero) min.

### Overseas Operator Center (OOC):

Table TMZONE also provides the time differences, in min (ahead/behind), between the Montreal #8 DMS office and the calling NPA-NXX. The maximum time difference allowed presently in TOPS is 3.5 h.

## Datafill sequence and implications

Table CLGTRF must be datafilled after table TMZONE.

## Table size

800 to 12 800 tuples

## Datafill

The following table lists datafill for table TMZONE.

### Field descriptions (Sheet 1 of 2)

Field	Subfield or refinement	Entry	Explanation and action
NPANXX		see subfields	Key into table TMZONE. This field consists of subfields CLGNPA and CLGNXX.  <b>Note:</b> The combination of subfields CLGNPA and CLGNXX must be known to table CLGTRF. Up to 16 combinations of the subfields can be datafilled in table TMZONE.
	CLGNPA	numeric (3 digits)	Calling numbering plan area served by TOPS. Enter the calling numbering plan area (NPA) code.
	CLGNXX	numeric (200 to 999)	Calling Nxx served by TOPS. Enter the calling NXX of the point served by Traffic Operator Position System (TOPS) originating the call.

**TMZONE** (end)**Field descriptions (Sheet 2 of 2)**

Field	Subfield or refinement	Entry	Explanation and action
SENSE		A or B	Sense of time zone variation. Enter A (ahead) or B (behind) to indicate that the local time of the NPA-NXX point is ahead or behind the TOPS local time.
MINUTES		0 to 300 (in increments of 30)	Time zone variation in minutes. Enter the variation in minutes between the NPA-NXX point local time and the TOPS local time.

**Datafill example**

An example of datafill for table TMZONE is shown below.

**MAP display example for table TMZONE**

NPANXX	SENSE	MINUTES
222 333	A	60





DMS-100 Family  
**North American DMS-100**  
Customer Data Schema Reference Manual  
Volume 10 of 12  
Data Schema SCCPTMR-TMZONE

Product Documentation - Dept. 3423  
Nortel Networks  
P.O. Box 13010  
RTP, NC 27709-3010  
Telephone: 1-877-662-5669  
email: [cits@nortelnetworks.com](mailto:cits@nortelnetworks.com)

Copyright © 1996-2001 Nortel Networks,  
All Rights Reserved

**NORTEL NETWORKS CONFIDENTIAL:** The information contained herein is the property of Nortel Networks and is strictly confidential. Except as expressly authorized in writing by Nortel Networks, the holder shall keep all information contained herein confidential, shall disclose the information only to its employees with a need to know, and shall protect the information, in whole or in part, from disclosure and dissemination to third parties with the same degree of care it uses to protect its own confidential information, but with no less than reasonable care. Except as expressly authorized in writing by Nortel Networks, the holder is granted no rights to use the information contained herein.

Information is subject to change without notice. Nortel Networks reserves the right to make changes in design or components as progress in engineering and manufacturing may warrant. Changes or modification to the DMS-100 without the express consent of Nortel Networks may void its warranty and void the user's authority to operate the equipment.

Nortel Networks, the Nortel Networks logo, the Globemark, How the World Shares Ideas, Unified Networks, DMS, DMS-100, Helmsman, MAP, Meridian, Nortel, Northern Telecom, NT, Supernode, and TOPS are trademarks of Nortel Networks.

Publication number: 297-8021-351  
Product release: LET0015 and up  
Document release: Standard 05.02  
Date: May 2001  
Printed in the United States of America

